

Technical
Specification



Flygt 3171, 50Hz

Table of Contents

F-pump, Standard Motor	2
Product description.....	2
Motor rating and performance curves.....	5
F-pump, Premium Efficiency Motor (IE3)	8
Product description.....	8
Motor rating and performance curves.....	11
N-pump, Standard Motor	14
Product description.....	14
Motor rating and performance curves.....	17
N-pump, Premium Efficiency Motor (IE3)	22
Product description.....	22
Motor rating and performance curves.....	25
Dimensions and Weight, Standard Motor	30
Drawings.....	30
Dimensions and Weight, Premium Efficiency Motor (IE3)	37
Drawings.....	37

F-pump, Standard Motor

Product description



Usage

A submersible chopper pump for liquid manure, fish waste, or heavily contaminated sewage and sludge. The N-hydraulic is fitted with a cutting insert ring. Both impeller and insert ring are manufactured in durable Hard-Iron™.

Denomination

Type	Non explosion proof version	Explosion proof version	Pressure class	Installation types
Hard-Iron™ Chopper	3171.350	3171.390	MT – Medium head HT – High head SH – Super head	P, S, T, Z

The pump can be used in the following installations:

- P** Semi permanent, wet well arrangement with pump installed on two guide bars with automatic connection to discharge.
- S** Portable semi permanent, wet well arrangement with hose coupling or flange for connection to discharge pipeline.
- T** Vertical permanent, dry well arrangement with flange connection to suction and discharge piping.
- Z** Horizontal permanent, dry well arrangement with flange connection to suction and discharge piping.

Application limits

Feature	Description
Liquid temperature	Maximum 40°C, (104°F)
Liquid temperature, warm water version	Maximum 70°C, (158°F)
Depth of immersion	Maximum 20 m (65 ft)
pH of the pumped liquid	5.5 - 14
Liquid density	Maximum 1100 kg/m ³

Motor data

Feature	Description
Motor type	Squirrel-cage induction motor
Frequency	50 Hz
Power supply	3-phase
Starting method	<ul style="list-style-type: none"> • Direct on-line • Star-delta • Variable Frequency Drive (VFD)
Number of starts per hour	Maximum 30
Code compliance	IEC 60034-1
Rated output variation	±10%
Voltage variation	<ul style="list-style-type: none"> • Continuously running: Maximum ±5% • Intermittent running: Maximum ±10%
Voltage imbalance between phases	Maximum 2%
Stator insulation class	H (180°C, 356°F)

Cables

Application	Type
Direct-on-line start or Y/D start with two cables	Flygt SUBCAB® - a heavy duty 4 cores motor power cable with two twisted pair screened control cores. Conductor insulation rating of 90°C, which allows for increased current. Superior mechanical strength and high abrasion and tear resistant. Chemical resistant within pH 3-10 and ozone, oil, and flame resistant. Used up to 70°C water temperature. Cables < 10 mm ² with unscreened control cores.
Y/D start	Flygt SUBCAB® - a heavy duty 7 cores motor power cable with two twisted pair screened control cores. Conductor insulation rating of 90°C, which allows for increased current. Superior mechanical strength and high abrasion and tear resistant. Chemical resistant within pH 3-10 and ozone, oil, and flame resistant. Used up to 70°C water temperature. Cables < 7G6 mm ² with unscreened control cores.
Variable Frequency drive	Screened Flygt SUBCAB® - a heavy duty 4 screened cores motor power cable with four twisted pair screened control cores. Conductor insulation rating of 90°C, which allows for increased current. Superior mechanical strength and high abrasion and tear resistant. Chemical resistant within pH 3-10 and ozone, oil, and flame resistant. Used up to 70°C water temperature.

Monitoring equipment

- Thermal contacts opening temperature 140° C (284° F)
- Leakage sensor in the inspection chamber (FLS 10)

Materials

Table 1: Major parts except mechanical seals

Denomination	Material	ASTM	EN
Major castings	Cast iron, gray	35B	GJL-250
Pump housing	Cast iron, gray	35B	GJL-250
Impeller	Cast iron, Hard-Iron™	A 532 IIIA	GJN-HB555(XCR23)
Insert ring	Cast iron, Hard-Iron™	A 532 IIIA	GJN-HB555(XCR23)
Cooling jacket, inner	Aluminum	AA 1050A	AW-1050A
Cooling jacket, outer, alternative 1	Steel	GR65	S235JRG2
Cooling jacket, outer, alternative 2	Stainless steel	AISI 316L	1.4404,1.4432, ...
Lifting handle	Stainless steel	AISI 316L	1.4404,1.4432, ...
Shaft	Stainless steel	AISI 431	1.4057+QT800
Screws and nuts	Stainless steel, A4	AISI 316L, 316, 316Ti	1.4401,1.4404, ...
O-rings, alternative 1	Nitrile rubber (NBR) 70° IRH	-	-
O-rings, alternative 2	Fluorinated rubber (FPM) 70° IRH	-	-
Glycol, part no 903708	Heat transfer fluid based on monopropylene glycol. Fulfills FDA 184.1666/182.6285.	-	-

Table 2: Mechanical seals

Alternative	Inner seal	Outer seal
1	Corrosion resistant cemented carbide/ Corrosion resistant cemented carbide	Corrosion resistant cemented carbide/ Corrosion resistant cemented carbide
2	Corrosion resistant cemented carbide/ Corrosion resistant cemented carbide	Silicon carbide/ Silicon carbide

Surface treatment

Priming	Finish
Painted with a primer, see internal standard M0700.00.0002	Navy gray color NCS 5804-B07G. Two-component high-solid top coating, see internal standard M0700.00.0004 for standard painting and M0700.00.0008 for special painting.

Options

- Warm liquid version (non-explosion proof versions)
- Sensors: Thermistor, FLS, Pt 100, VIS 10
- Surface treatment (Epoxy)
- Zinc anodes
- Other cables

Accessories

Discharge connections, adapters, hose connections, and other mechanical accessories.

Electrical accessories such as pump controller, control panels, starters, monitoring relays, cables.

Motor rating and performance curves

These are examples of motor rating and curves, for more information contact your local sales and service representative.

Star-delta starting current is 1/3 of Direct on-line starting current.

MT

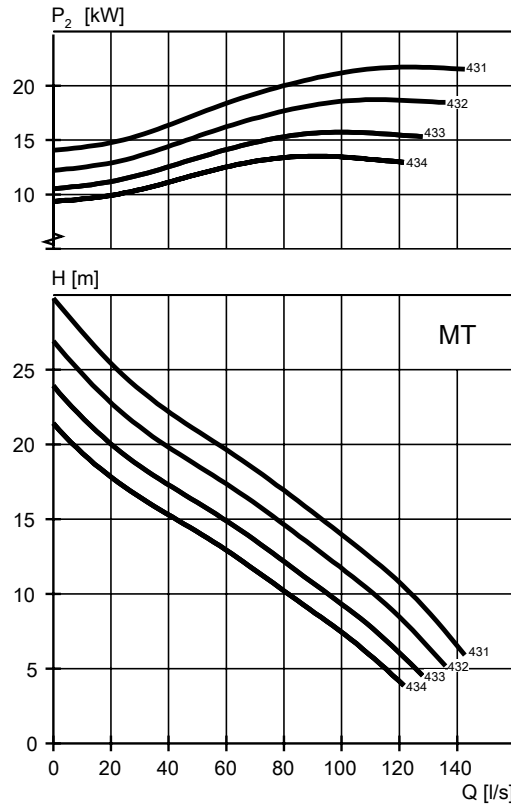

WS005115C

Table 3: 400 V, 50 Hz, 3-phase

Rated power, kW	Rated power, hp	Curve/ Impeller No	Revolutions per minute, rpm	Rated current, A	Starting current, A	Power factor, cos φ	Installation
15	20	434	1460	29	177	0.87	P,S,T,Z
18.5	25	433	1460	36	223	0.84	P,S,T,Z
18.5	25	434	1460	36	223	0.84	P,S,T,Z
22	30	431	1460	41	248	0.88	P,S,T,Z
22	30	432	1460	41	248	0.88	P,S,T,Z
22	30	433	1460	41	248	0.88	P,S,T,Z
22	30	434	1460	41	248	0.88	P,S,T,Z

HT

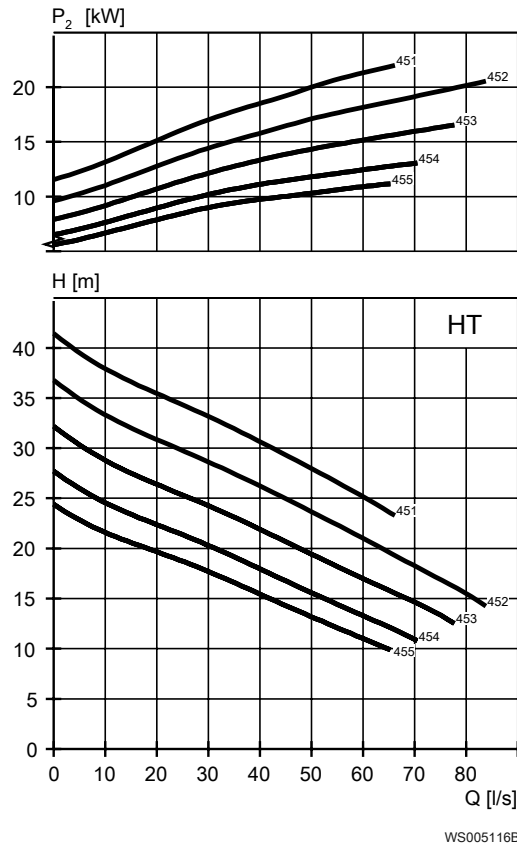
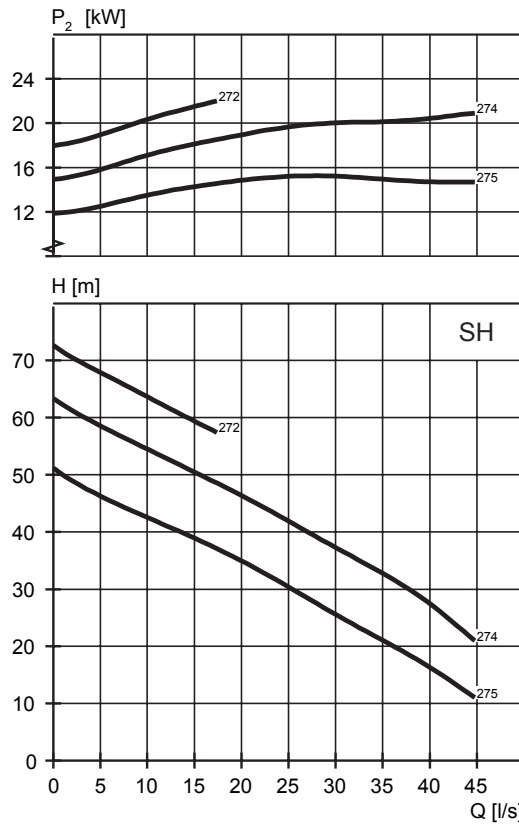

Table 4: 400 V, 50 Hz, 3-phase

Rated power, kW	Rated power, hp	Curve/ Impeller No	Revolutions per minute, rpm	Rated current, A	Starting current, A	Power factor, cos φ	Installation
15	20	454	1460	29	177	0.87	P,S,T,Z
15	20	455	1460	29	177	0.87	P,S,T,Z
18.5	25	453	1460	36	223	0.84	P,S,T,Z
18.5	25	454	1460	36	223	0.84	P,S,T,Z
18.5	25	455	1460	36	223	0.84	P,S,T,Z
22	30	451	1460	41	248	0.88	P,S,T,Z
22	30	452	1460	41	248	0.88	P,S,T,Z
22	30	453	1460	41	248	0.88	P,S,T,Z
22	30	454	1460	41	248	0.88	P,S,T,Z
22	30	455	1460	41	248	0.88	P,S,T,Z

SH



WS005117A

Table 5: 400 V, 50 Hz, 3-phase

Rated power, kW	Rated power, hp	Curve/ Impeller No	Revolutions per minute, rpm	Rated current, A	Starting current, A	Power factor, $\cos \varphi$	Installation
22	30	272	2925	38	269	0.93	P,S,T,Z
22	30	274	2925	38	269	0.93	P,S,T,Z
22	30	275	2925	38	269	0.93	P,S,T,Z

F-pump, Premium Efficiency Motor (IE3)

Product description



Usage

A submersible chopper pump for liquid manure, fish waste, or heavily contaminated sewage and sludge. The N-hydraulic is fitted with a cutting insert ring. Both impeller and insert ring are manufactured in durable Hard-Iron™.

Denomination

Type	Non explosion proof version	Explosion proof version	Pressure class	Installation types
Hard-Iron™ Chopper	3171.840	3171.850	MT – Medium head HT – High head SH – Super head	P, S, T, Z

The pump can be used in the following installations:

- P** Semi permanent, wet well arrangement with pump installed on two guide bars with automatic connection to discharge.
- S** Portable semi permanent, wet well arrangement with hose coupling or flange for connection to discharge pipeline.
- T** Vertical permanent, dry well arrangement with flange connection to suction and discharge piping.
- Z** Horizontal permanent, dry well arrangement with flange connection to suction and discharge piping.

Application limits

Feature	Description
Liquid temperature	Maximum 40°C, (104°F)
Depth of immersion	Maximum 20 m (65 ft)
pH of the pumped liquid	5.5 - 14
Liquid density	Maximum 1100 kg/m ³

Motor data

Feature	Description
Motor type	Squirrel-cage induction motor
Frequency	50 Hz
Power supply	3-phase
Starting method	<ul style="list-style-type: none"> • Direct on-line • Star-delta • Variable Frequency Drive (VFD)
Number of starts per hour	Maximum 30
Code compliance	IEC 60034-1
Rated output variation	±10%
Voltage variation	<ul style="list-style-type: none"> • Continuously running: Maximum ±5% • Intermittent running: Maximum ±10%
Voltage imbalance between phases	Maximum 2%
Stator insulation class	H (180°C, 356°F)

Cables

Application	Type
Direct-on-line start or Y/D start with two cables	Flygt SUBCAB® - a heavy duty 4 cores motor power cable with two twisted pair screened control cores. Conductor insulation rating of 90°C, which allows for increased current. Superior mechanical strength and high abrasion and tear resistant. Chemical resistant within pH 3-10 and ozone, oil, and flame resistant. Used up to 70°C water temperature. Cables < 10 mm ² with unscreened control cores.
Y/D start	Flygt SUBCAB® - a heavy duty 7 cores motor power cable with two twisted pair screened control cores. Conductor insulation rating of 90°C, which allows for increased current. Superior mechanical strength and high abrasion and tear resistant. Chemical resistant within pH 3-10 and ozone, oil, and flame resistant. Used up to 70°C water temperature. Cables < 7G6 mm ² with unscreened control cores.
Variable Frequency drive	Screened Flygt SUBCAB® - a heavy duty 4 screened cores motor power cable with four twisted pair screened control cores. Conductor insulation rating of 90°C, which allows for increased current. Superior mechanical strength and high abrasion and tear resistant. Chemical resistant within pH 3-10 and ozone, oil, and flame resistant. Used up to 70°C water temperature.

Monitoring equipment

- Thermal contacts opening temperature 140° C (284° F)
- Leakage sensor in the inspection chamber (FLS 10)

Materials

Table 6: Major parts except mechanical seals

Denomination	Material	ASTM	EN
Major castings	Cast iron, gray	35B	GJL-250
Pump housing	Cast iron, gray	35B	GJL-250
Impeller	Cast iron, Hard-Iron™	A 532 IIIA	GJN-HB555(XCR23)
Insert ring	Cast iron, Hard-Iron™	A 532 IIIA	GJN-HB555(XCR23)
Cooling jacket, inner	Aluminum	AA 1050A	AW-1050A
Cooling jacket, outer	Stainless steel	AISI 316L	1.4404,1.4432, ...
Lifting handle	Stainless steel	AISI 316L	1.4404,1.4432, ...
Shaft	Stainless steel	AISI 431	1.4057+QT800
Screws and nuts	Stainless steel, A4	AISI 316L, 316, 316Ti	1.4401,1.4404, ...
O-rings, alternative 1	Nitrile rubber (NBR) 70° IRH	-	-
O-rings, alternative 2	Fluorinated rubber (FPM) 70° IRH	-	-
Glycol, part no 903708	Heat transfer fluid based on monopropylene glycol. Fulfills FDA 184.1666/182.6285.	-	-

Table 7: Mechanical seals

Alternative	Inner seal	Outer seal
1	Corrosion resistant cemented carbide/ Corrosion resistant cemented carbide	Corrosion resistant cemented carbide/ Corrosion resistant cemented carbide
2	Corrosion resistant cemented carbide/ Corrosion resistant cemented carbide	Silicon carbide/ Silicon carbide

Surface treatment

Priming	Finish
Painted with a primer, see internal standard M0700.00.0002	Navy gray color NCS 5804-B07G. Two-component high-solid top coating, see internal standard M0700.00.0004 for standard painting and M0700.00.0008 for special painting.

Options

- Sensors: Thermistor, FLS, Pt 100, VIS 10
- Surface treatment (Epoxy)
- Zinc anodes
- Other cables

Accessories

Discharge connections, adapters, hose connections, and other mechanical accessories. Electrical accessories such as pump controller, control panels, starters, monitoring relays, cables.

Motor rating and performance curves

These are examples of motor rating and curves, for more information contact your local sales and service representative.

Star-delta starting current is 1/3 of Direct on-line starting current.

MT

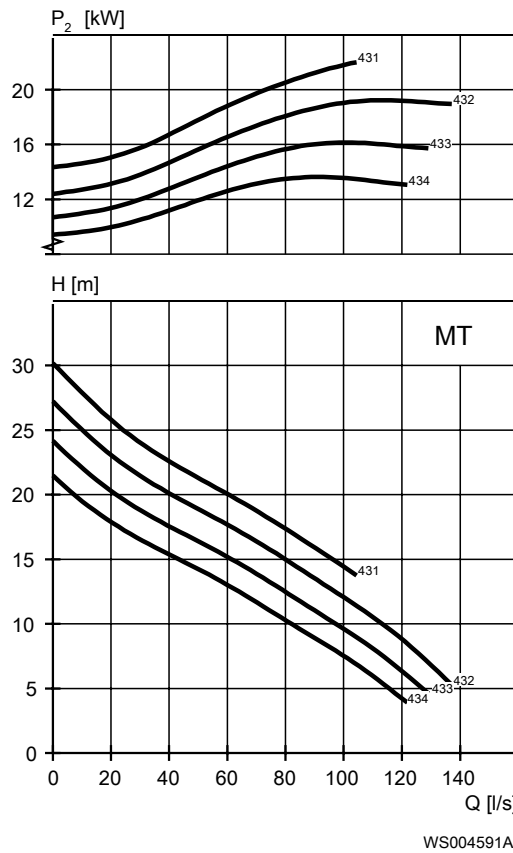

Table 8: 400 V, 50 Hz, 3-phase

Rated power, kW	Rated power, hp	Curve/ Impeller No	Revolutions per minute, rpm	Rated current, A	Starting current, A	Power factor, cos φ	Installation
15	20	433	1475	26	214	0.89	P,S,T,Z
15	20	434	1475	26	214	0.89	P,S,T,Z
18.5	25	432	1475	32	246	0.9	P,S,T,Z
18.5	25	433	1475	32	246	0.9	P,S,T,Z
18.5	25	434	1475	32	246	0.9	P,S,T,Z
22	30	431	1475	40	295	0.86	P,S,T,Z
22	30	432	1475	40	295	0.86	P,S,T,Z
22	30	433	1475	40	295	0.86	P,S,T,Z
22	30	434	1475	40	295	0.86	P,S,T,Z

HT

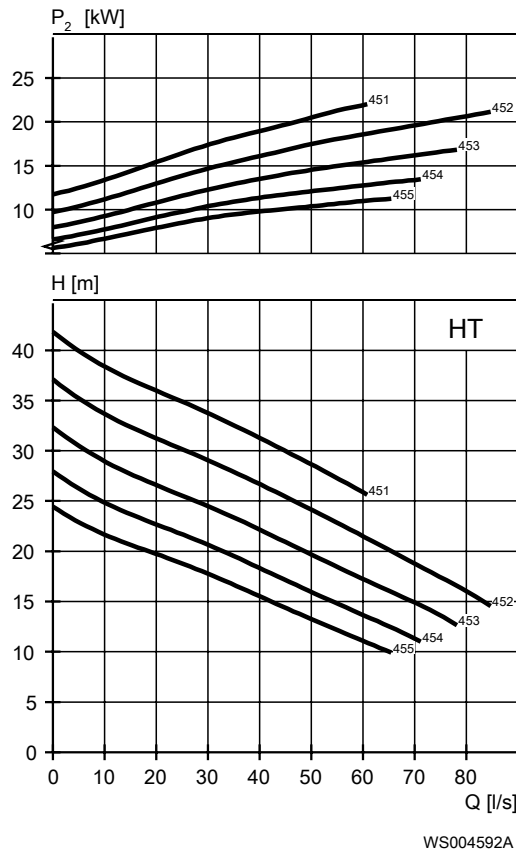

Table 9: 400 V, 50 Hz, 3-phase

Rated power, kW	Rated power, hp	Curve/ Impeller No	Revolutions per minute, rpm	Rated current, A	Starting current, A	Power factor, cos φ	Installation
15	20	453	1475	26	214	0.89	P,S,T,Z
15	20	454	1475	26	214	0.89	P,S,T,Z
15	20	455	1475	26	214	0.89	P,S,T,Z
18.5	25	452	1475	32	246	0.9	P,S,T,Z
18.5	25	453	1475	32	246	0.9	P,S,T,Z
18.5	25	454	1475	32	246	0.9	P,S,T,Z
18.5	25	455	1475	32	246	0.9	P,S,T,Z
22	30	451	1475	40	295	0.86	P,S,T,Z
22	30	452	1475	40	295	0.86	P,S,T,Z
22	30	453	1475	40	295	0.86	P,S,T,Z
22	30	454	1475	40	295	0.86	P,S,T,Z
22	30	455	1475	40	295	0.86	P,S,T,Z

SH

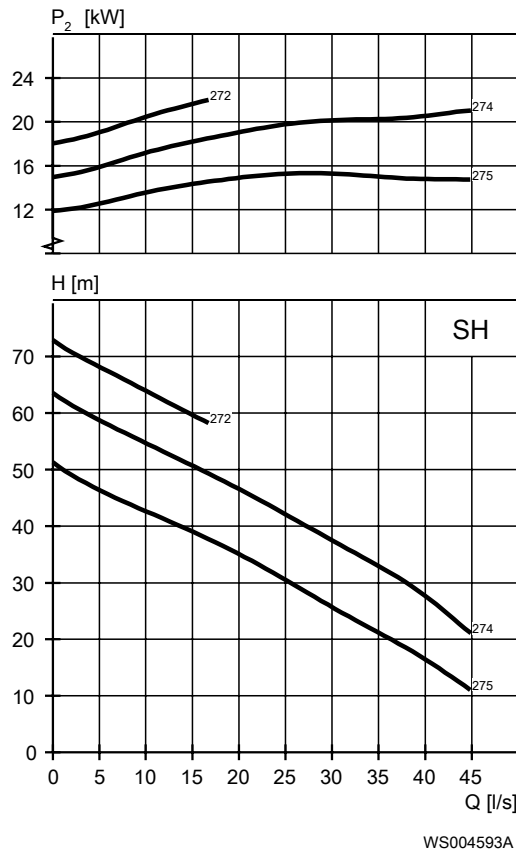

Table 10: 400 V, 50 Hz, 3-phase

Rated power, kW	Rated power, hp	Curve/ Impeller No	Revolutions per minute, rpm	Rated current, A	Starting current, A	Power factor, $\cos \varphi$	Installation
22	30	272	2935	37	297	0.93	P,S,T,Z
22	30	274	2935	37	297	0.93	P,S,T,Z
22	30	275	2935	37	297	0.93	P,S,T,Z

N-pump, Standard Motor

Product description



Usage

A submersible pump for efficient pumping of clean water, surface water, and wastewater containing solids or long-fibered material. The pump is designed for sustained high efficiency. For abrasive media, Hard-Iron™ is required.

Denomination

Type	Non explosion proof version	Explosion proof version	Pressure class	Installation types
Cast iron	3171.181	3171.091	LT – Low head MT – Medium head HT – High head SH – Super head	P, S, T, Z
Hard-Iron™	3171.185	3171.095	LT – Low head MT – Medium head HT – High head SH – Super head	P, S, T, Z

The pump can be used in the following installations:

- P** Semi permanent, wet well arrangement with pump installed on two guide bars with automatic connection to discharge.
- S** Portable semi permanent, wet well arrangement with hose coupling or flange for connection to discharge pipeline.
- T** Vertical permanent, dry well arrangement with flange connection to suction and discharge piping.
- Z** Horizontal permanent, dry well arrangement with flange connection to suction and discharge piping.

Application limits

Feature	Description
Liquid temperature	Maximum 40°C, (104°F)

Feature	Description
Liquid temperature, warm water version	Maximum 70°C, (158°F)
Depth of immersion	Maximum 20 m (65 ft)
pH of the pumped liquid	5.5 - 14
Liquid density	Maximum 1100 kg/m ³

Motor data

Feature	Description
Motor type	Squirrel-cage induction motor
Frequency	50 Hz
Power supply	3-phase
Starting method	<ul style="list-style-type: none"> • Direct on-line • Star-delta • Variable Frequency Drive (VFD)
Number of starts per hour	Maximum 30
Code compliance	IEC 60034-1
Rated output variation	±10%
Voltage variation	<ul style="list-style-type: none"> • Continuously running: Maximum ±5% • Intermittent running: Maximum ±10%
Voltage imbalance between phases	Maximum 2%
Stator insulation class	H (180°C, 356°F)

Cables

Application	Type
Direct-on-line start or Y/D start with two cables	Flygt SUBCAB® - a heavy duty 4 cores motor power cable with two twisted pair screened control cores. Conductor insulation rating of 90°C, which allows for increased current. Superior mechanical strength and high abrasion and tear resistant. Chemical resistant within pH 3-10 and ozone, oil, and flame resistant. Used up to 70°C water temperature. Cables < 10 mm ² with unscreened control cores.
Y/D start	Flygt SUBCAB® - a heavy duty 7 cores motor power cable with two twisted pair screened control cores. Conductor insulation rating of 90°C, which allows for increased current. Superior mechanical strength and high abrasion and tear resistant. Chemical resistant within pH 3-10 and ozone, oil, and flame resistant. Used up to 70°C water temperature. Cables < 7G6 mm ² with unscreened control cores.

Application	Type
Variable Frequency drive	Screened Flygt SUBCAB® - a heavy duty 4 screened cores motor power cable with four twisted pair screened control cores. Conductor insulation rating of 90°C, which allows for increased current. Superior mechanical strength and high abrasion and tear resistant. Chemical resistant within pH 3-10 and ozone, oil, and flame resistant. Used up to 70°C water temperature.

Monitoring equipment

- Thermal contacts opening temperature 140° C (284° F)
- Leakage sensor in the inspection chamber (FLS 10)

Materials

Table 11: Major parts except mechanical seals

Denomination	Material	ASTM	EN
Major castings	Cast iron, gray	35B	GJL-250
Pump housing	Cast iron, gray	35B	GJL-250
Impeller, alternative 1	Cast iron, gray	35B	GJL-250
Impeller, alternative 2	Cast iron, Hard-Iron™	A 532 IIIA	GJN-HB555(XCR23)
Insert ring, alternative 1	Cast iron, gray	35B	GJL-250
Insert ring, alternative 2	Cast iron, Hard-Iron™	A 532 IIIA	GJN-HB555(XCR23)
Cooling jacket, inner	Aluminum	AA 1050A	AW-1050A
Cooling jacket, outer, alternative 1	Steel	GR65	S235JRG2
Cooling jacket, outer, alternative 2	Stainless steel	AISI 316L	1.4404,1.4432, ...
Lifting handle	Stainless steel	AISI 316L	1.4404,1.4432, ...
Shaft	Stainless steel	AISI 431	1.4057+QT800
Screws and nuts	Stainless steel, A4	AISI 316L, 316, 316Ti	1.4401,1.4404, ...
O-rings, alternative 1	Nitrile rubber (NBR) 70° IRH	-	-
O-rings, alternative 2	Fluorinated rubber (FPM) 70° IRH	-	-
Glycol, part no 903708	Heat transfer fluid based on monopropylene glycol. Fulfills FDA 184.1666/182.6285.	-	-

Table 12: Mechanical seals

Alternative	Inner seal	Outer seal
1	Corrosion resistant cemented carbide/ Corrosion resistant cemented carbide	Corrosion resistant cemented carbide/ Corrosion resistant cemented carbide
2	Corrosion resistant cemented carbide/ Corrosion resistant cemented carbide	Silicon carbide/ Silicon carbide

Surface treatment

Priming	Finish
Painted with a primer, see internal standard M0700.00.0002	Navy gray color NCS 5804-B07G. Two-component high-solid top coating, see internal standard M0700.00.0004 for standard painting and M0700.00.0008 for special painting.

Options

- Warm liquid version (non-explosion proof versions)
- Sensors: Thermistor, FLS, Pt 100, VIS 10
- Surface treatment (Epoxy)
- Zinc anodes
- Other cables

Accessories

Discharge connections, adapters, hose connections, and other mechanical accessories.

Electrical accessories such as pump controller, control panels, starters, monitoring relays, cables.

Motor rating and performance curves

These are examples of motor rating and curves, for more information contact your local sales and service representative.

Star-delta starting current is 1/3 of Direct on-line starting current.

LT

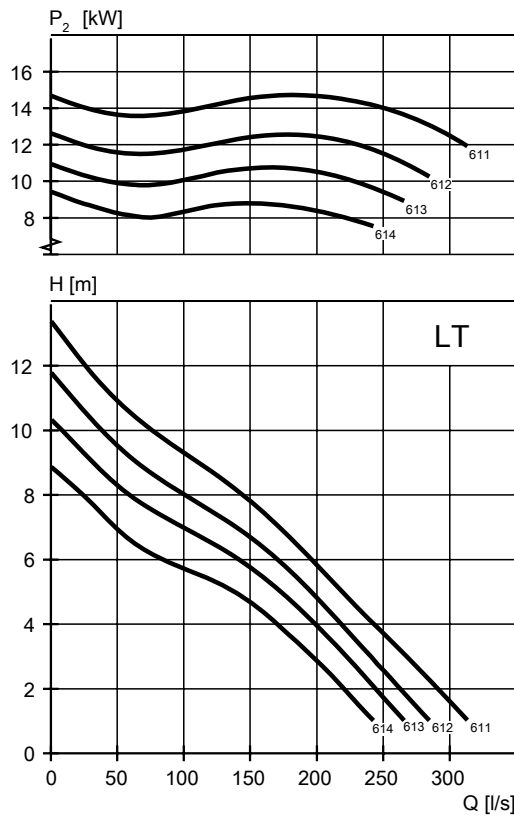

WS005208A

Table 13: 400 V, 50 Hz, 3-phase

Rated power, kW	Rated power, hp	Curve/ Impeller No	Revolutions per minute, rpm	Rated current, A	Starting current, A	Power factor, $\cos \varphi$	Installation
15	20	611	965	30	167	0.84	P,S,T,Z
15	20	612	965	30	167	0.84	P,S,T,Z
15	20	613	965	30	167	0.84	P,S,T,Z
15	20	614	965	30	167	0.84	P,S,T,Z

MT

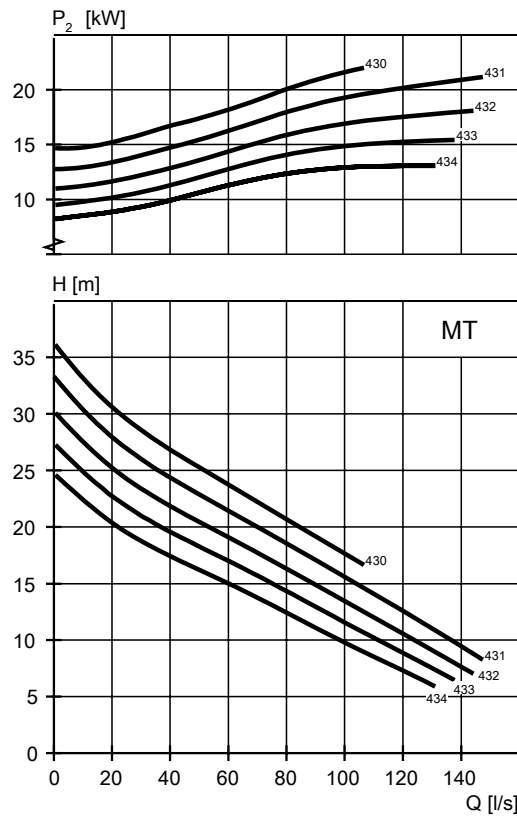

WS005209A

Table 14: 400 V, 50 Hz, 3-phase

Rated power, kW	Rated power, hp	Curve/ Impeller No	Revolutions per minute, rpm	Rated current, A	Starting current, A	Power factor, cos φ	Installation
15	20	433	1460	29	177	0.87	P,S,T,Z
15	20	434	1460	29	177	0.87	P,S,T,Z
18.5	25	432	1460	36	223	0.84	P,S,T,Z
18.5	25	433	1460	36	223	0.84	P,S,T,Z
18.5	25	434	1460	36	223	0.84	P,S,T,Z
22	30	430	1460	41	248	0.88	P,S,T,Z
22	30	431	1460	41	248	0.88	P,S,T,Z
22	30	432	1460	41	248	0.88	P,S,T,Z
22	30	433	1460	41	248	0.88	P,S,T,Z
22	30	434	1460	41	248	0.88	P,S,T,Z

¹ Only applicable for 3171.181 and 3171.091

HT

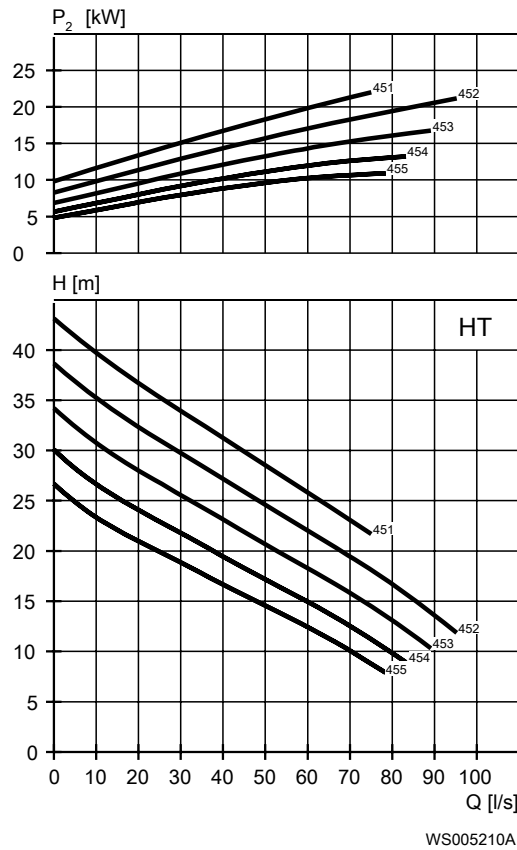

Table 15: 400 V, 50 Hz, 3-phase

Rated power, kW	Rated power, hp	Curve/ Impeller No	Revolutions per minute, rpm	Rated current, A	Starting current, A	Power factor, cos φ	Installation
15	20	451	1460	29	177	0.87	P,S,T,Z
15	20	452	1460	29	177	0.87	P,S,T,Z
15	20	453	1460	29	177	0.87	P,S,T,Z
15	20	454	1460	29	177	0.87	P,S,T,Z
15	20	455	1460	29	177	0.87	P,S,T,Z
18.5	25	451	1460	36	223	0.84	P,S,T,Z
18.5	25	452	1460	36	223	0.84	P,S,T,Z
18.5	25	453	1460	36	223	0.84	P,S,T,Z
18.5	25	454	1460	36	223	0.84	P,S,T,Z
18.5	25	455	1460	36	223	0.84	P,S,T,Z
22	30	451	1460	41	248	0.88	P,S,T,Z
22	30	452	1460	41	248	0.88	P,S,T,Z
22	30	453	1460	41	248	0.88	P,S,T,Z
22	30	454	1460	41	248	0.88	P,S,T,Z
22	30	455	1460	41	248	0.88	P,S,T,Z

SH

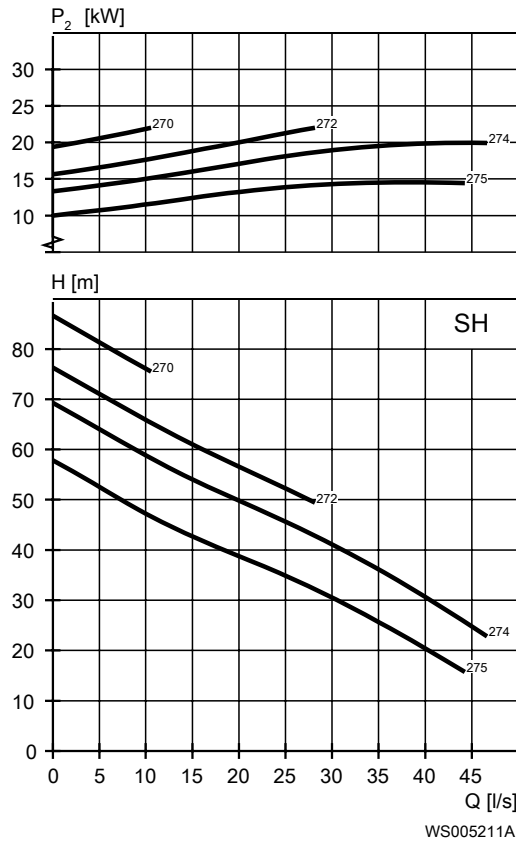

Table 16: 400 V, 50 Hz, 3-phase

Rated power, kW	Rated power, hp	Curve/ Impeller No	Revolutions per minute, rpm	Rated current, A	Starting current, A	Power factor, cos φ	Installation
22	30	270	2925	38	269	0.93	P,S,T,Z
22	30	272	2925	38	269	0.93	P,S,T,Z
22	30	274	2925	38	269	0.93	P,S,T,Z
22	30	275	2925	38	269	0.93	P,S,T,Z

N-pump, Premium Efficiency Motor (IE3)

Product description



Usage

A submersible pump for efficient pumping of clean water, surface water, and wastewater containing solids or long-fibered material. The pump is designed for sustained high efficiency. For abrasive media, Hard-Iron™ is required.

Denomination

Type	Non explosion proof version	Explosion proof version	Pressure class	Installation types
Cast iron	3171.800	3171.810	LT – Low head MT – Medium head HT – High head SH – Super head	P, S, T, Z
Hard-Iron™	3171.820	3171.830	LT – Low head MT – Medium head HT – High head SH – Super head	P, S, T, Z

The pump can be used in the following installations:

- P** Semi permanent, wet well arrangement with pump installed on two guide bars with automatic connection to discharge.
- S** Portable semi permanent, wet well arrangement with hose coupling or flange for connection to discharge pipeline.
- T** Vertical permanent, dry well arrangement with flange connection to suction and discharge piping.
- Z** Horizontal permanent, dry well arrangement with flange connection to suction and discharge piping.

Application limits

Feature	Description
Liquid temperature	Maximum 40°C, (104°F)
Depth of immersion	Maximum 20 m (65 ft)
pH of the pumped liquid	5.5 - 14
Liquid density	Maximum 1100 kg/m ³

Motor data

Feature	Description
Motor type	Squirrel-cage induction motor
Frequency	50 Hz
Power supply	3-phase
Starting method	<ul style="list-style-type: none"> • Direct on-line • Star-delta • Variable Frequency Drive (VFD)
Number of starts per hour	Maximum 30
Code compliance	IEC 60034-1
Rated output variation	±10%
Voltage variation	<ul style="list-style-type: none"> • Continuously running: Maximum ±5% • Intermittent running: Maximum ±10%
Voltage imbalance between phases	Maximum 2%
Stator insulation class	H (180°C, 356°F)

Cables

Application	Type
Direct-on-line start or Y/D start with two cables	Flygt SUBCAB® - a heavy duty 4 cores motor power cable with two twisted pair screened control cores. Conductor insulation rating of 90°C, which allows for increased current. Superior mechanical strength and high abrasion and tear resistant. Chemical resistant within pH 3-10 and ozone, oil, and flame resistant. Used up to 70°C water temperature. Cables < 10 mm ² with unscreened control cores.
Y/D start	Flygt SUBCAB® - a heavy duty 7 cores motor power cable with two twisted pair screened control cores. Conductor insulation rating of 90°C, which allows for increased current. Superior mechanical strength and high abrasion and tear resistant. Chemical resistant within pH 3-10 and ozone, oil, and flame resistant. Used up to 70°C water temperature. Cables < 7G6 mm ² with unscreened control cores.

N-pump, Premium Efficiency Motor (IE3)

Application	Type
Variable Frequency drive	Screened Flygt SUBCAB® - a heavy duty 4 screened cores motor power cable with four twisted pair screened control cores. Conductor insulation rating of 90°C, which allows for increased current. Superior mechanical strength and high abrasion and tear resistant. Chemical resistant within pH 3-10 and ozone, oil, and flame resistant. Used up to 70°C water temperature.

Monitoring equipment

- Thermal contacts opening temperature 140° C (284° F)
- Leakage sensor in the inspection chamber (FLS 10)

Materials

Table 17: Major parts except mechanical seals

Denomination	Material	ASTM	EN
Major castings	Cast iron, gray	35B	GJL-250
Pump housing	Cast iron, gray	35B	GJL-250
Impeller, alternative 1	Cast iron, gray	35B	GJL-250
Impeller, alternative 2	Cast iron, Hard-Iron™	A 532 IIIA	GJN-HB555(XCR23)
Insert ring, alternative 1	Cast iron, gray	35B	GJL-250
Insert ring, alternative 2	Cast iron, Hard-Iron™	A 532 IIIA	GJN-HB555(XCR23)
Cooling jacket, inner	Aluminum	AA 1050A	AW-1050A
Cooling jacket, outer	Stainless steel	AISI 316L	1.4404,1.4432, ...
Lifting handle	Stainless steel	AISI 316L	1.4404,1.4432, ...
Shaft	Stainless steel	AISI 431	1.4057+QT800
Screws and nuts	Stainless steel, A4	AISI 316L, 316, 316Ti	1.4401,1.4404, ...
O-rings, alternative 1	Nitrile rubber (NBR) 70° IRH	-	-
O-rings, alternative 2	Fluorinated rubber (FPM) 70° IRH	-	-
Glycol, part no 903708	Heat transfer fluid based on monopropylene glycol. Fulfills FDA 184.1666/182.6285.	-	-

Table 18: Mechanical seals

Alternative	Inner seal	Outer seal
1	Corrosion resistant cemented carbide/ Corrosion resistant cemented carbide	Corrosion resistant cemented carbide/ Corrosion resistant cemented carbide
2	Corrosion resistant cemented carbide/ Corrosion resistant cemented carbide	Silicon carbide/ Silicon carbide

Surface treatment

Priming	Finish
Painted with a primer, see internal standard M0700.00.0002	Navy gray color NCS 5804-B07G. Two-component high-solid top coating, see internal standard M0700.00.0004 for standard painting and M0700.00.0008 for special painting.

Options

- Sensors: Thermistor, FLS, Pt 100, VIS 10
- Surface treatment (Epoxy)
- Zinc anodes
- Other cables

Accessories

Discharge connections, adapters, hose connections, and other mechanical accessories.
Electrical accessories such as pump controller, control panels, starters, monitoring relays, cables.

Motor rating and performance curves

These are examples of motor rating and curves, for more information contact your local sales and service representative.

Star-delta starting current is 1/3 of Direct on-line starting current.

LT

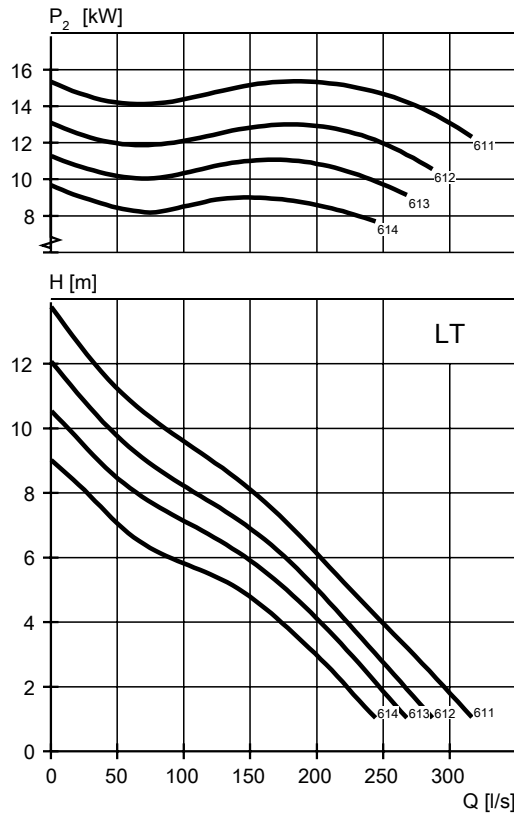

WS004583A

Table 19: 400 V, 50 Hz, 3-phase

Rated power, kW	Rated power, hp	Curve/ Impeller No	Revolutions per minute, rpm	Rated current, A	Starting current, A	Power factor, $\cos \varphi$	Installation
15.5	21	611	980	30	204	0.81	P,S,T,Z
15.5	21	612	980	30	204	0.81	P,S,T,Z
15.5	21	613	980	30	204	0.81	P,S,T,Z
15.5	21	614	980	30	204	0.81	P,S,T,Z

MT

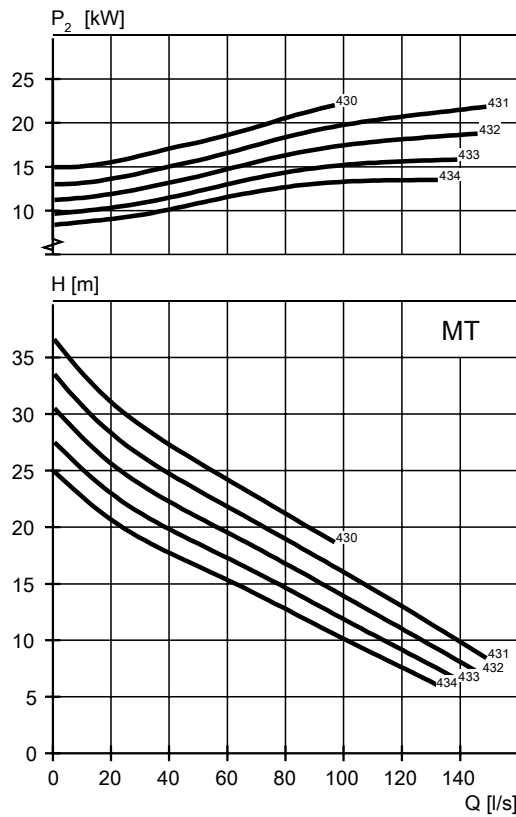

WS004584A

Table 20: 400 V, 50 Hz, 3-phase

Rated power, kW	Rated power, hp	Curve/ Impeller No	Revolutions per minute, rpm	Rated current, A	Starting current, A	Power factor, $\cos \varphi$	Installation
15	20	432	1475	26	214	0.89	P,S,T,Z
15	20	433	1475	26	214	0.89	P,S,T,Z
15	20	434	1475	26	214	0.89	P,S,T,Z
18.5	25	431	1475	32	246	0.9	P,S,T,Z
18.5	25	432	1475	32	246	0.9	P,S,T,Z
18.5	25	433	1475	32	246	0.9	P,S,T,Z
18.5	25	434	1475	32	246	0.9	P,S,T,Z
22	30	430	1475	40	295	0.86	P,S,T,Z
22	30	431	1475	40	295	0.86	P,S,T,Z
22	30	432	1475	40	295	0.86	P,S,T,Z
22	30	433	1475	40	295	0.86	P,S,T,Z
22	30	434	1475	40	295	0.86	P,S,T,Z

² Only applicable for 3171.800 and 3171.810

HT

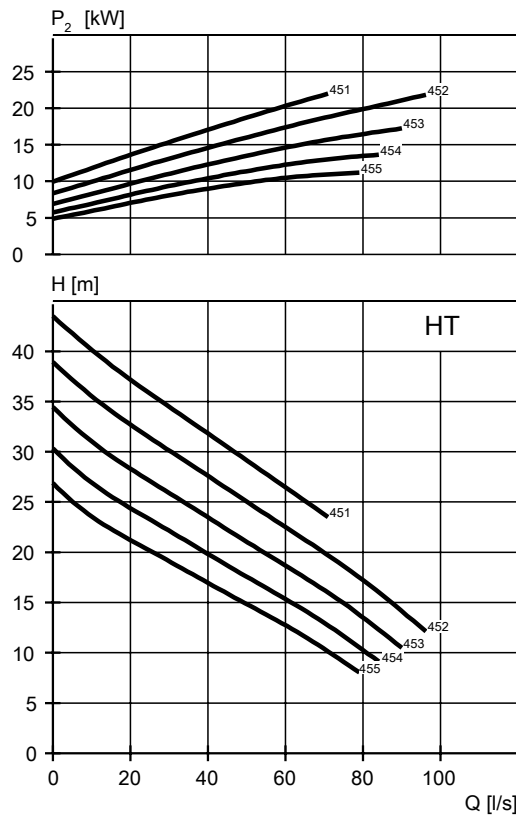

WS004585A

Table 21: 400 V, 50 Hz, 3-phase

Rated power, kW	Rated power, hp	Curve/ Impeller No	Revolutions per minute, rpm	Rated current, A	Starting current, A	Power factor, cos φ	Installation
15	20	451	1475	26	214	0.89	P,S,T,Z
15	20	452	1475	26	214	0.89	P,S,T,Z
15	20	453	1475	26	214	0.89	P,S,T,Z
15	20	454	1475	26	214	0.89	P,S,T,Z
15	20	455	1475	26	214	0.89	P,S,T,Z
18.5	25	451	1475	32	246	0.9	P,S,T,Z
18.5	25	452	1475	32	246	0.9	P,S,T,Z
18.5	25	453	1475	32	246	0.9	P,S,T,Z
18.5	25	454	1475	32	246	0.9	P,S,T,Z
18.5	25	455	1475	32	246	0.9	P,S,T,Z
22	30	451	1475	40	295	0.86	P,S,T,Z
22	30	452	1475	40	295	0.86	P,S,T,Z
22	30	453	1475	40	295	0.86	P,S,T,Z
22	30	454	1475	40	295	0.86	P,S,T,Z
22	30	455	1475	40	295	0.86	P,S,T,Z

SH

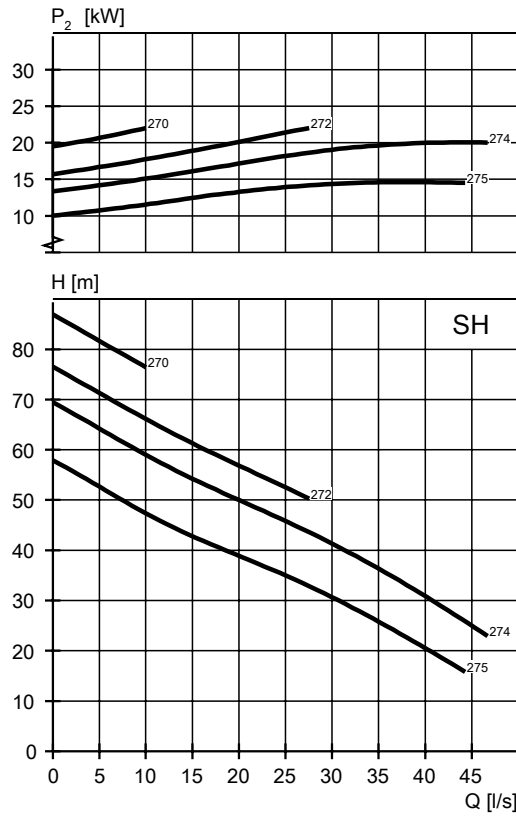

WS004586A

Table 22: 400 V, 50 Hz, 3-phase

Rated power, kW	Rated power, hp	Curve/ Impeller No	Revolutions per minute, rpm	Rated current, A	Starting current, A	Power factor, $\cos \varphi$	Installation
22	30	270	2935	37	297	0.93	P,S,T,Z
22	30	272	2935	37	297	0.93	P,S,T,Z
22	30	274	2935	37	297	0.93	P,S,T,Z
22	30	275	2935	37	297	0.93	P,S,T,Z

Dimensions and Weight, Standard Motor

Drawings

All drawings are available as Acrobat documents (.pdf) and AutoCad drawings (.dwg). Contact your local sales and service representative for more information.

All dimensions are in mm.

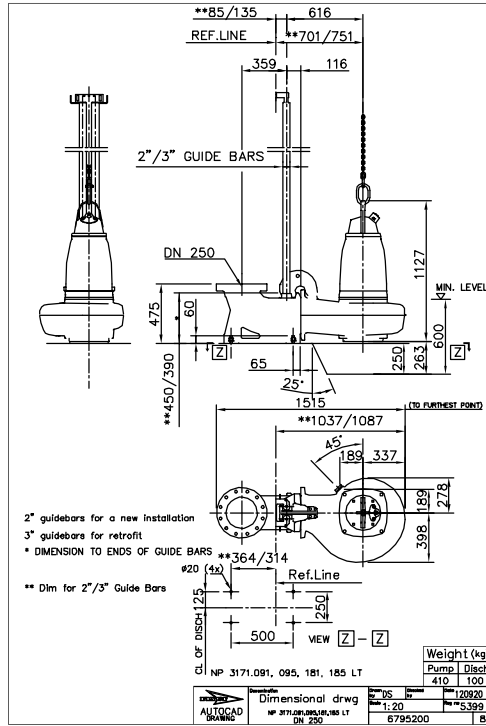

Figure 1: LT, P-installation

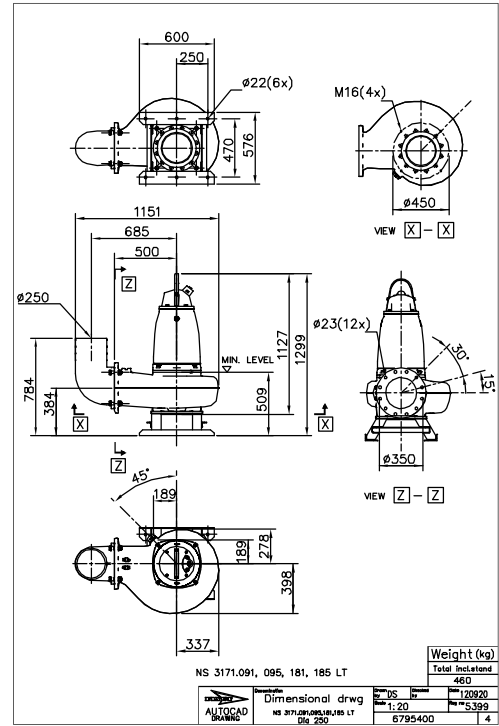

Figure 2: LT, S-installation

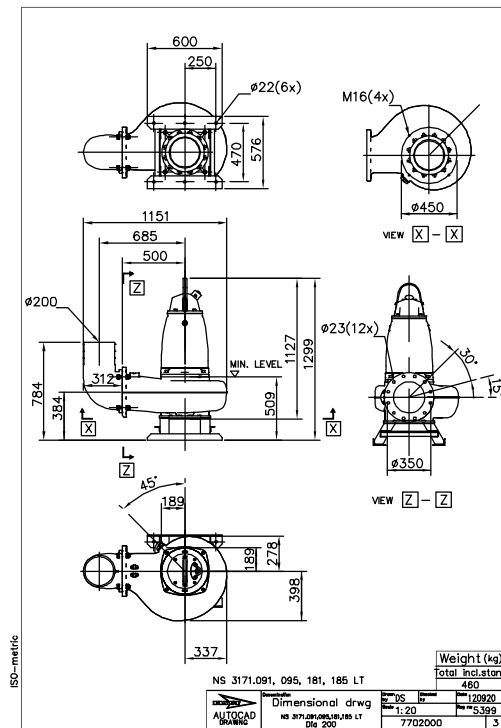

Figure 3: LT, S-installation

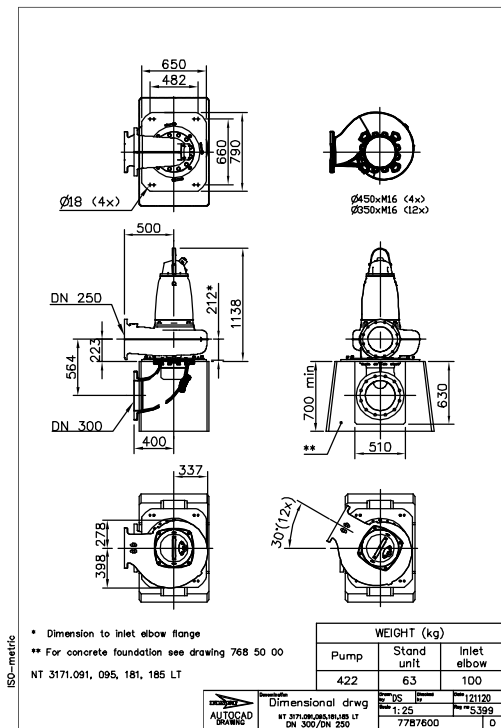

Figure 4: LT, T-installation

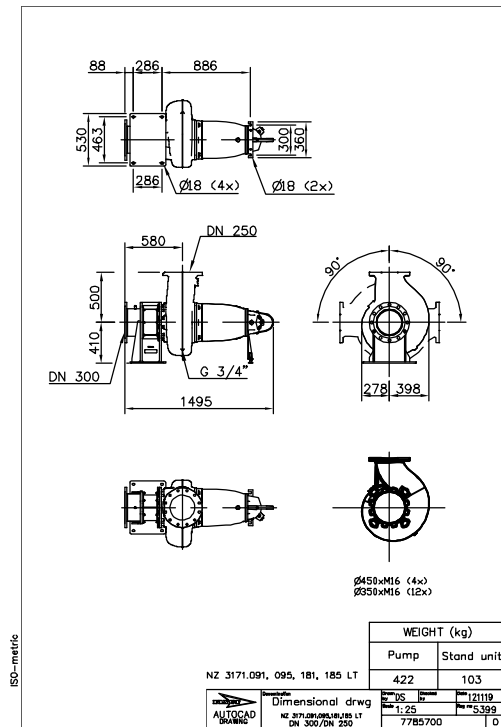

Figure 5: LT, Z-installation

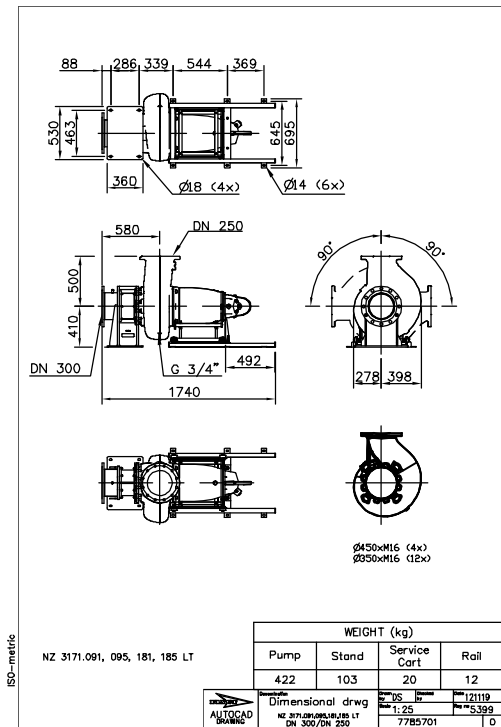

Figure 6: LT, Z-installation

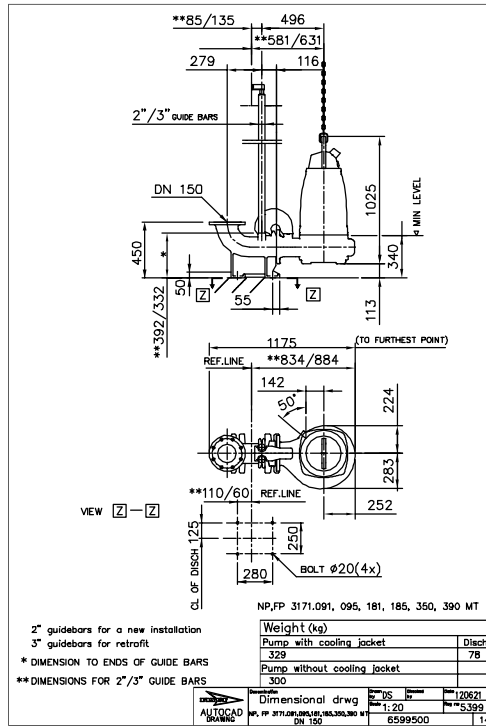

Figure 7: MT, P-installation

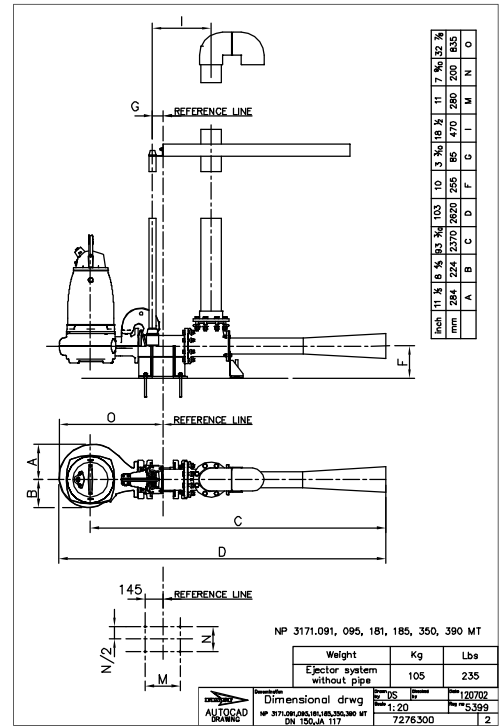

Figure 8: MT, P-installation

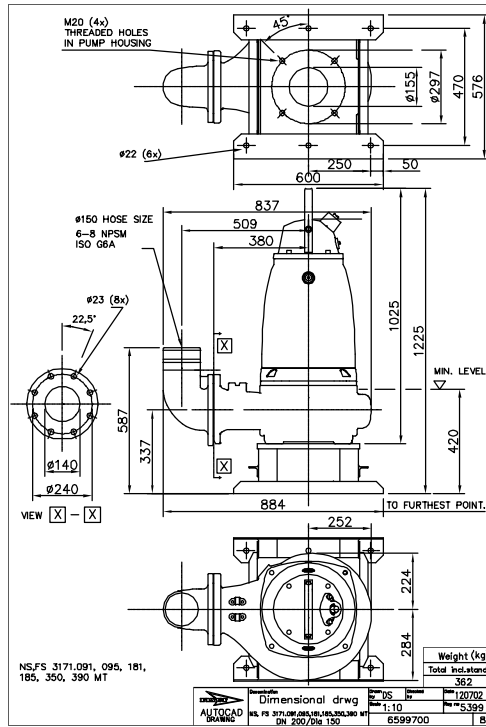

Figure 9: MT, S-installation

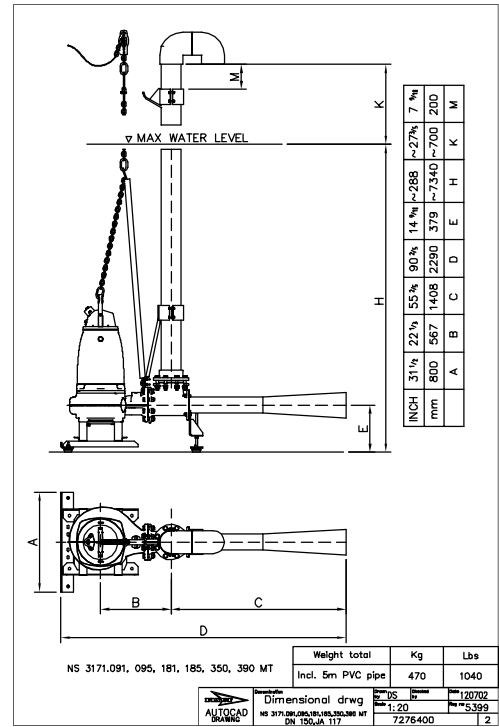

Figure 10: MT, S-installation

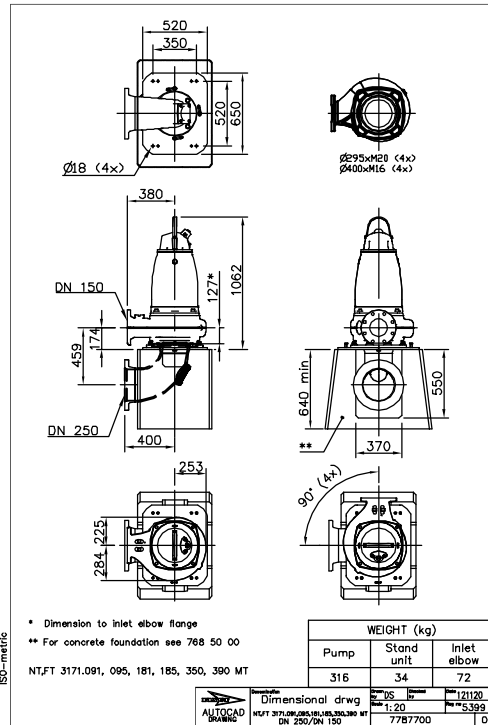

Figure 11: MT, T-installation

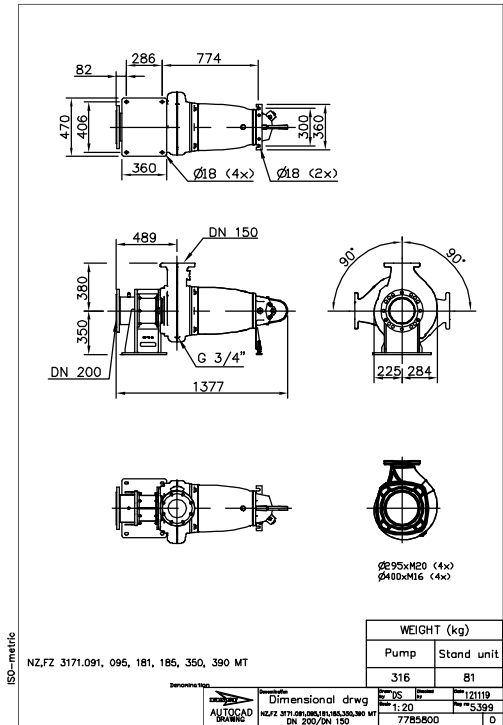

Figure 12: MT, Z-installation

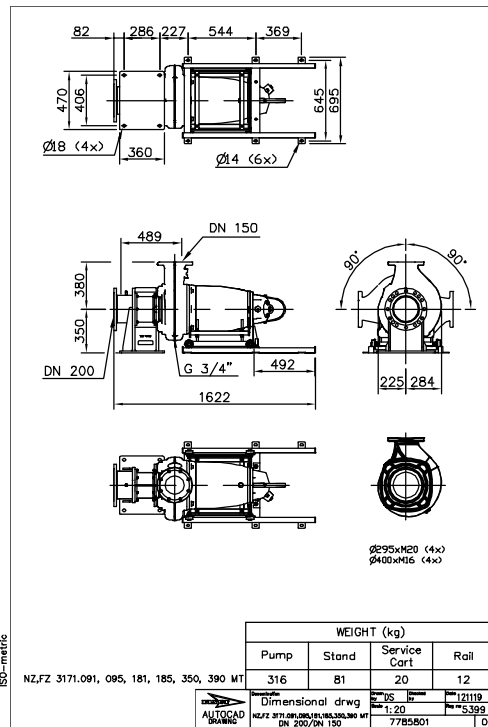

Figure 13: MT, Z-installation

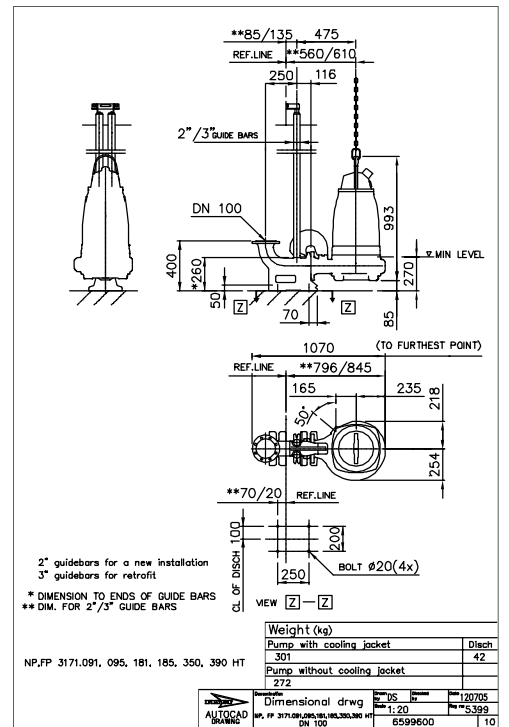

Figure 14: HT, P-installation

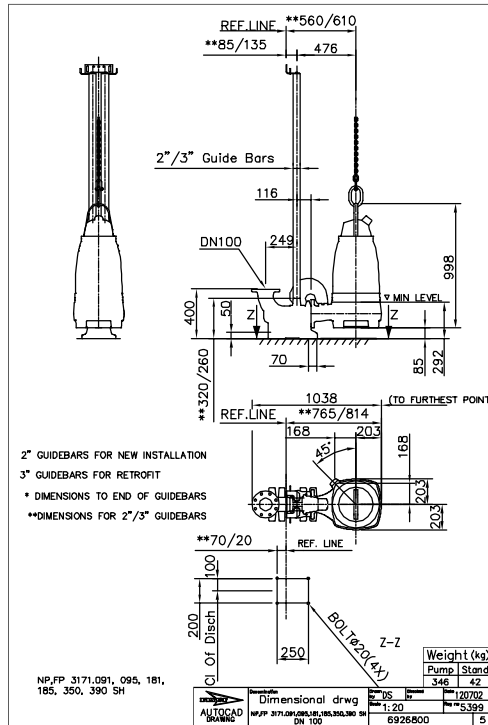

Figure 19: SH, P-installation

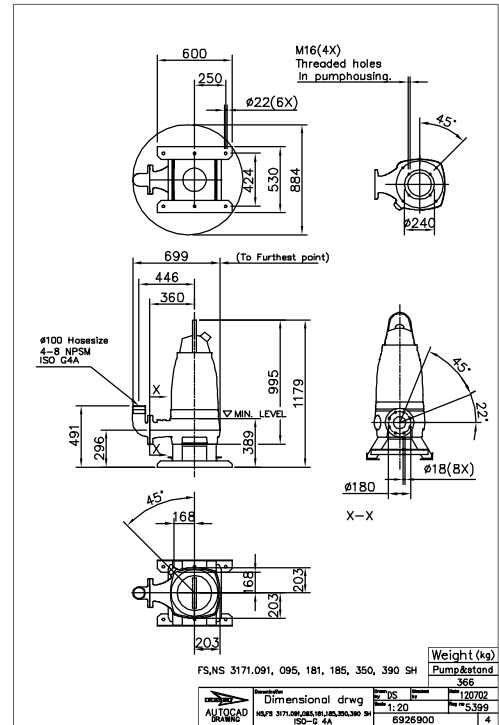

Figure 20: SH, S-installation

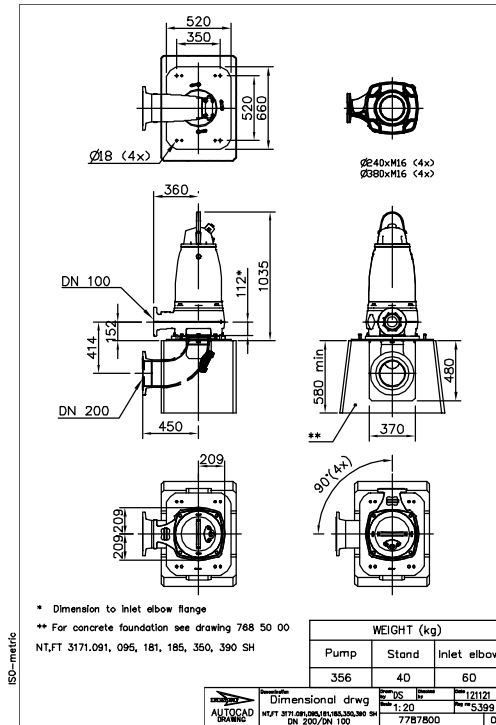

Figure 21: SH, T-installation

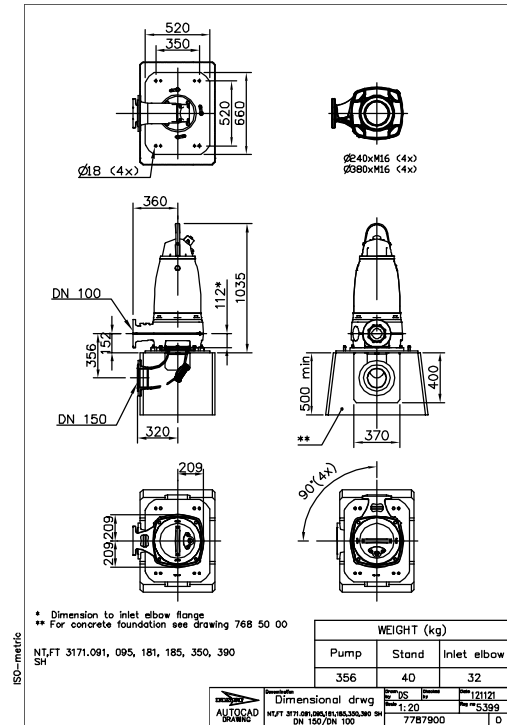

Figure 22: SH, T-installation

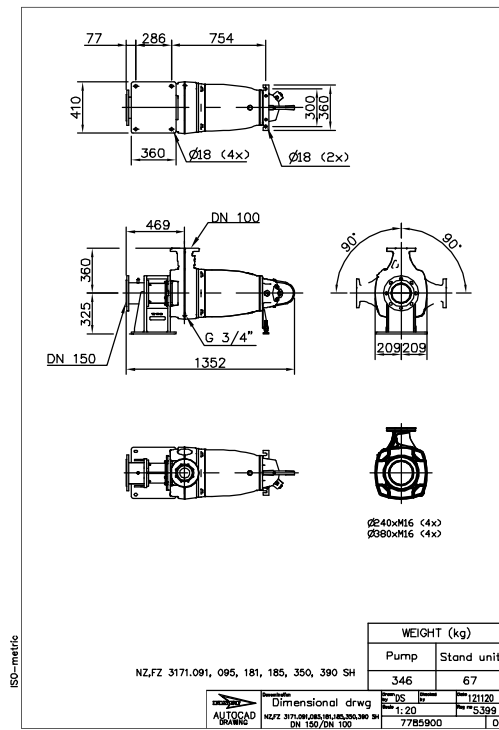

Figure 23: SH, Z-installation

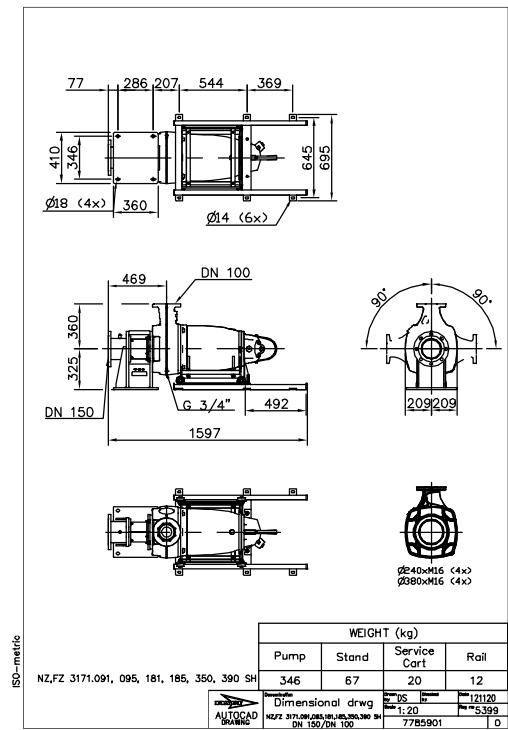

Figure 24: SH, Z-installation

Dimensions and Weight, Premium Efficiency Motor (IE3)

Drawings

All drawings are available as Acrobat documents (.pdf) and AutoCad drawings (.dwg). Contact your local sales and service representative for more information.

All dimensions are in mm.

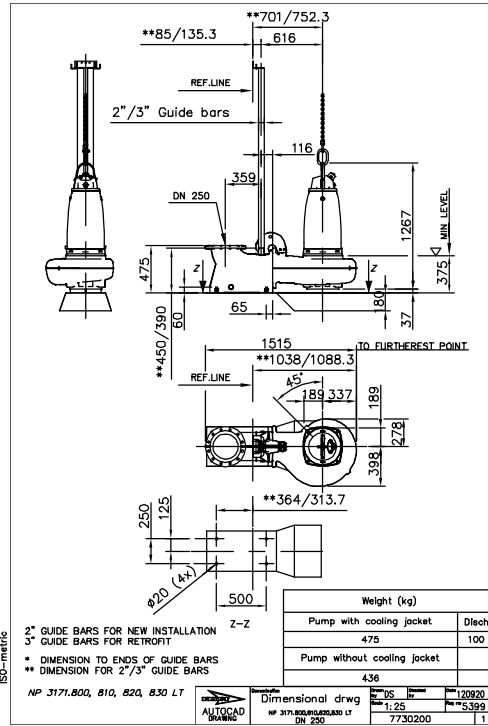

Figure 25: LT, P-installation

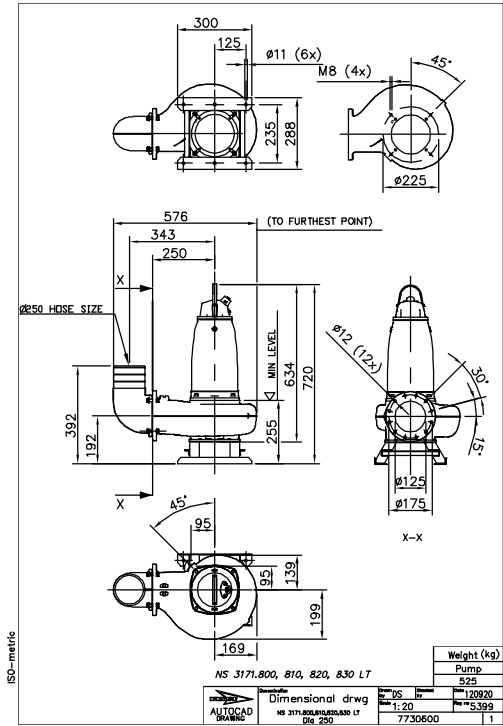

Figure 26: LT, S-installation

Dimensions and Weight, Premium Efficiency Motor (IE3)

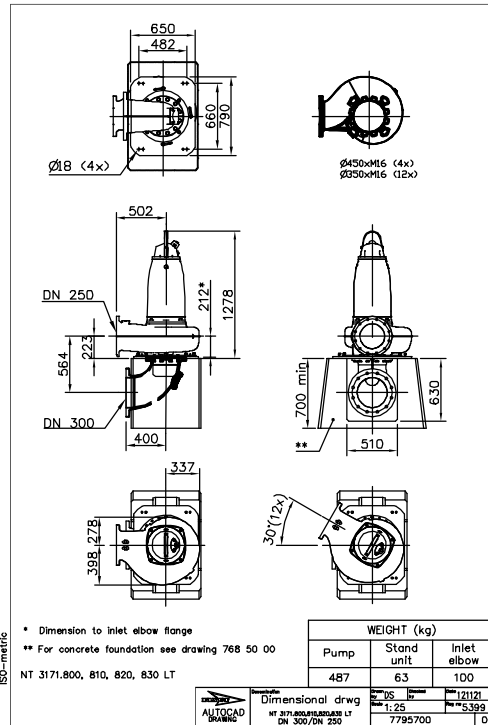

Figure 27: LT, T-installation

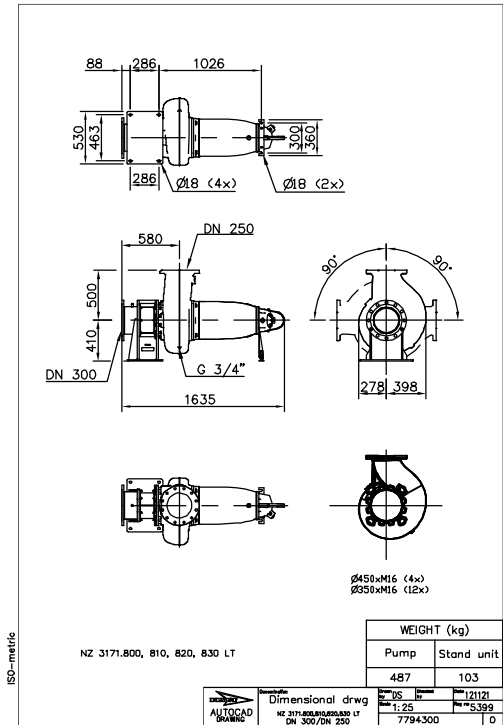

Figure 28: LT, Z-installation

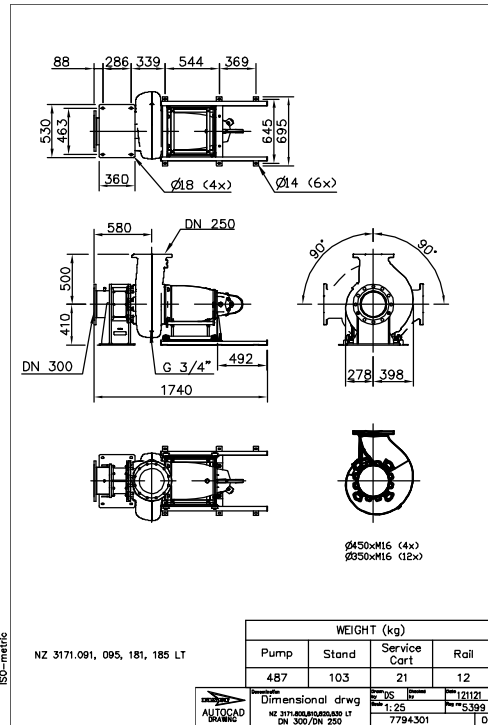

Figure 29: LT, Z-installation

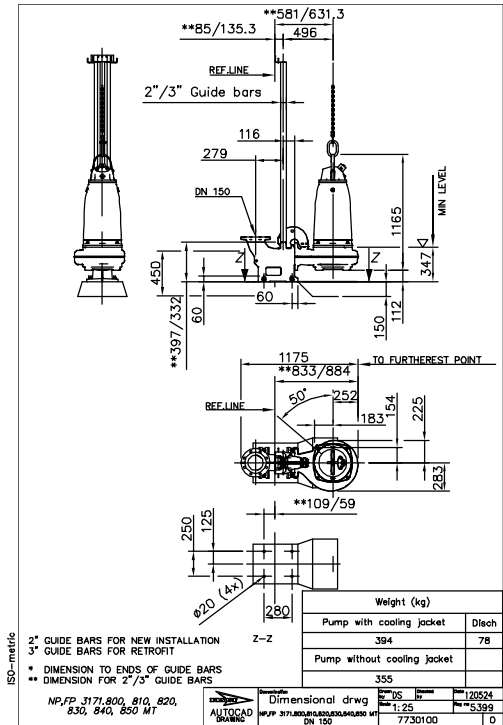

Figure 30: MT, P-installation

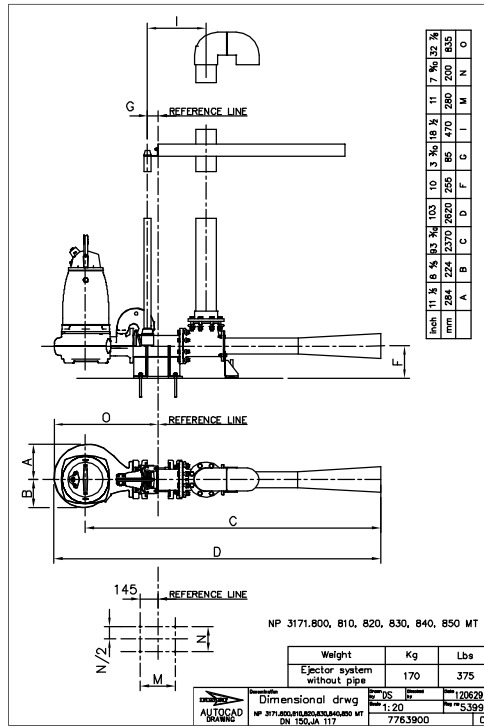

Figure 31: MT, P-installation

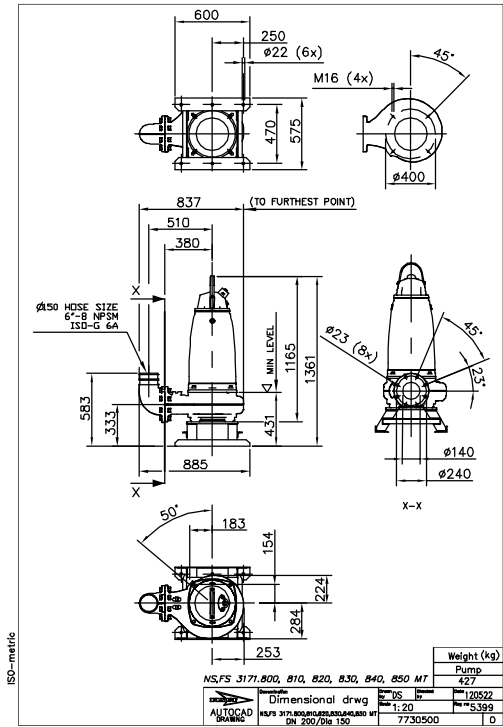

Figure 32: MT, S-installation

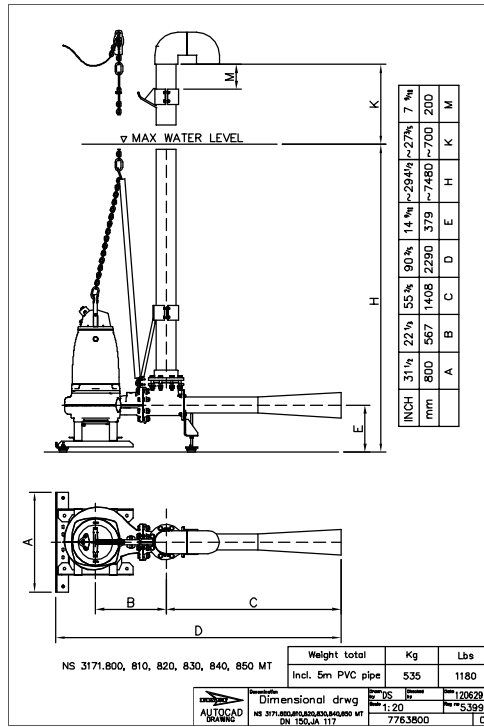

Figure 33: MT, S-installation

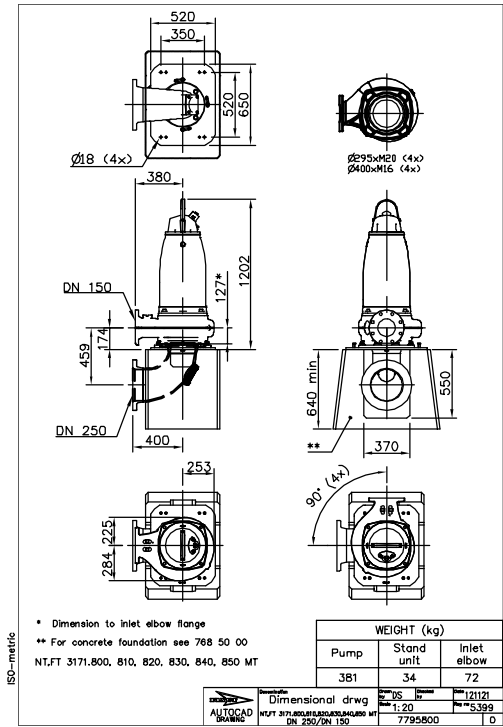

Figure 34: MT, T-installation

Dimensions and Weight, Premium Efficiency Motor (IE3)

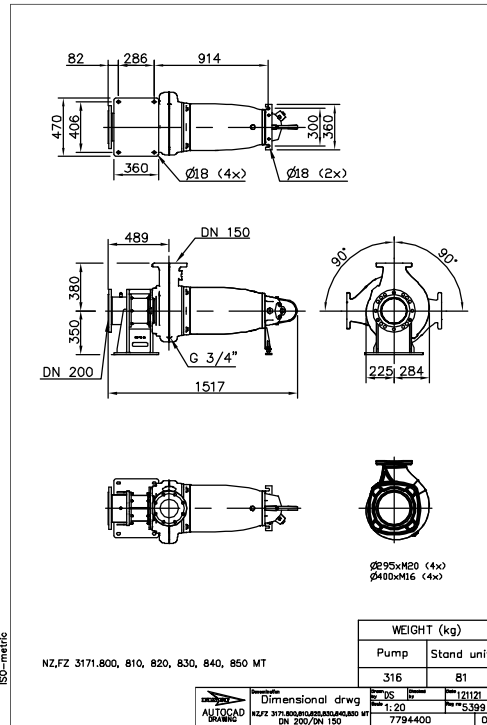

Figure 35: MT, Z-installation

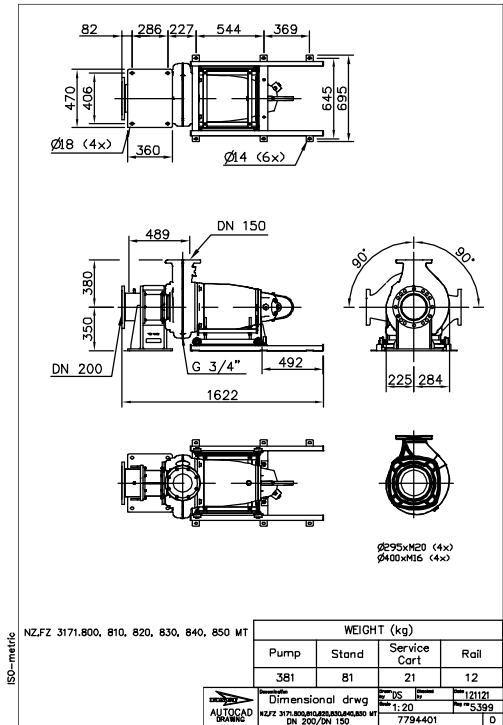

Figure 36: MT, Z-installation

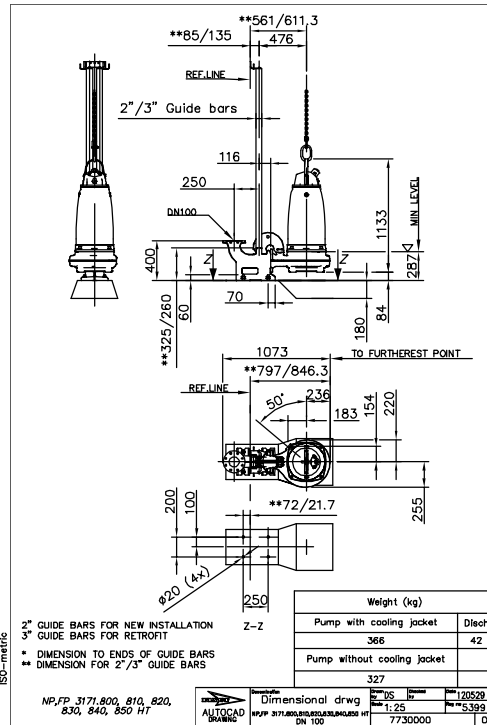

Figure 37: HT, P-installation

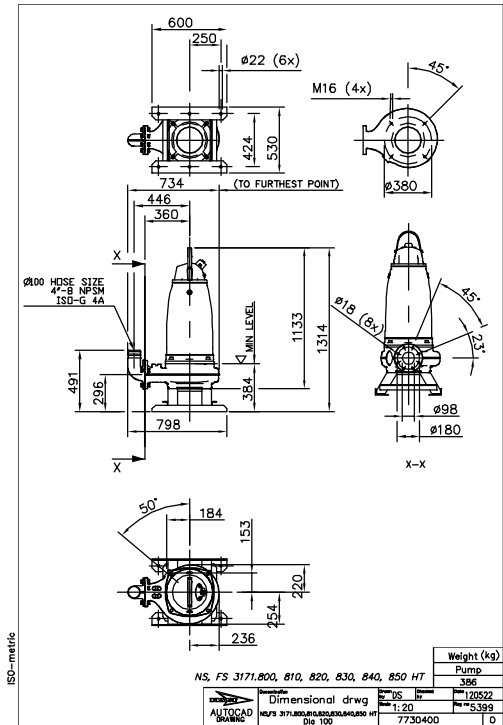

Figure 38: HT, S-installation

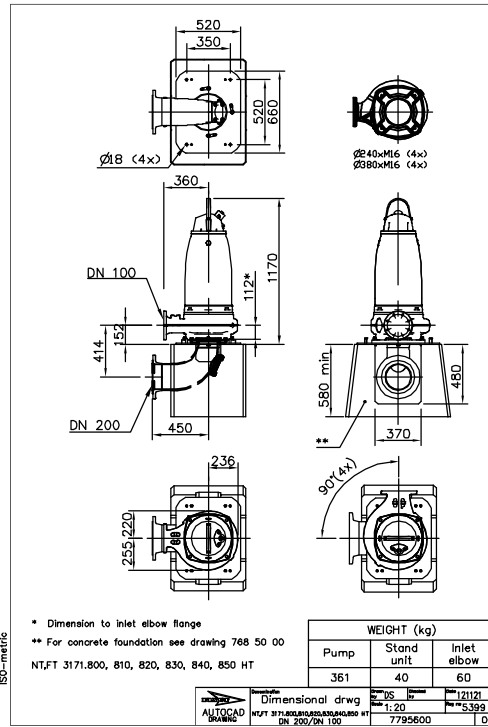

Figure 39: HT, T-installation

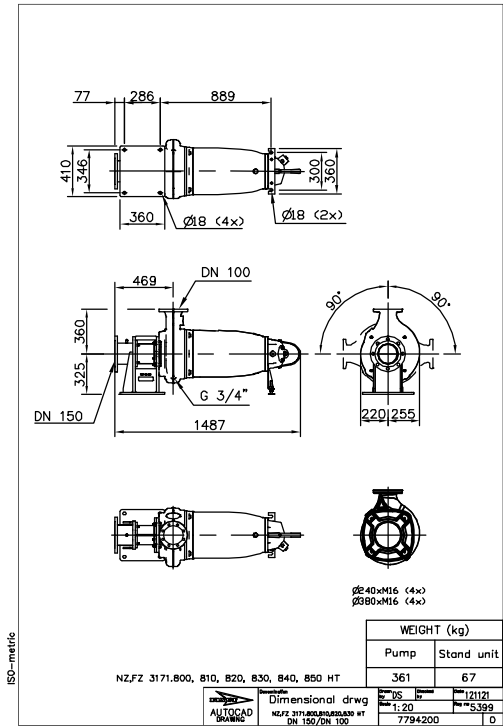

Figure 40: HT, Z-installation

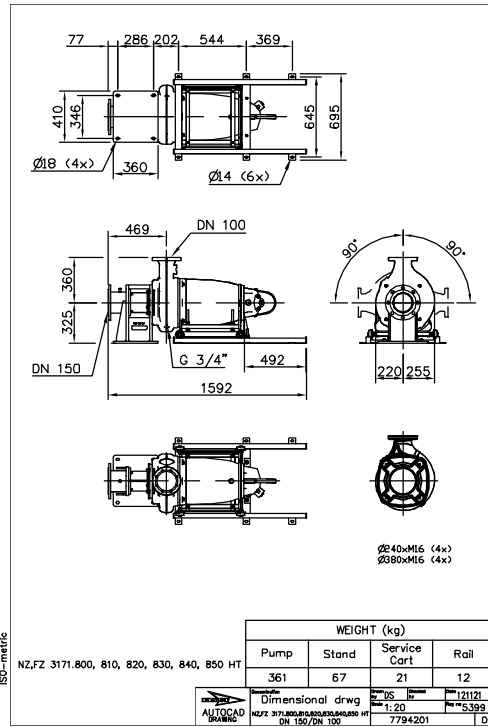

Figure 41: HT, Z-installation

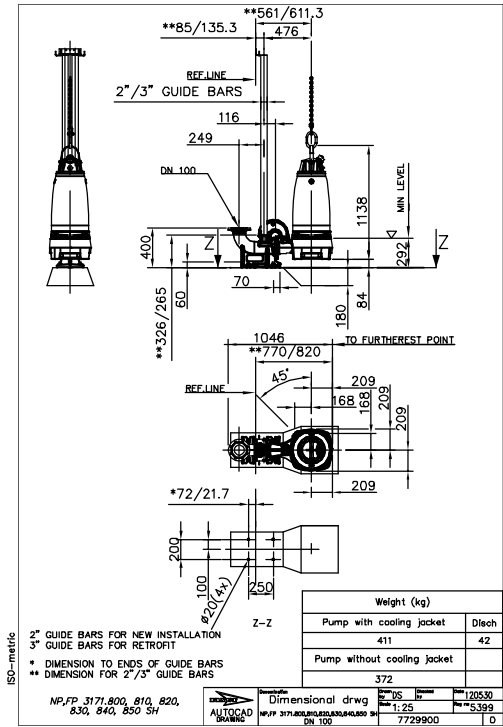

Figure 42: SH, P-installation

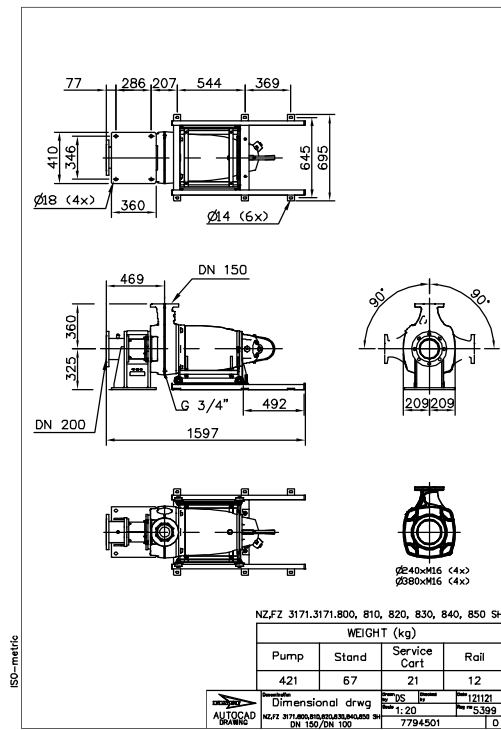

Figure 47: SH, Z-installation

