



# Flygt Submersible Pumps

AVAILABLE FOR RENTAL AND SALE



[www.motralec.com](http://www.motralec.com) / [service-commercial@motralec.com](mailto:service-commercial@motralec.com) / 01.39.97.65.10

# 2000 Series Dewatering Pumps

Flygt 2000 pumps easily handle chemically aggressive, mechanically abrasive or highly viscous fluids laden with particles. Flygt 2000 products are available in lightweight aluminum or corrosion-resistant cast iron. Some models are available in MSHA-approved versions.

## BS 2071

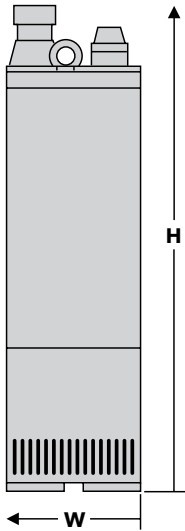

Model number: 2071.010  
 Motor rating: 1 $\emptyset$ : 4.1 HP@3425 RPM  
 3 $\emptyset$ : 6 HP@3335 RPM  
 Voltage (1 $\emptyset$ ): 230V  
 Full load amps: 17A  
 Voltage (3 $\emptyset$ ): 230V 460V 575V  
 Full load amps: 16A 8.1A 6.5A  
 Versions: 2" Standard (2 stage)  
 Imp. Code 236 (1 $\emptyset$ ), 231 (3 $\emptyset$ )  
 3" High volume  
 Imp. Code 216 (1 $\emptyset$ ), 212 (3 $\emptyset$ )  
 Hose connection: Male NPSM threaded  
 Pump dimensions: 7 1/4" W (max.) x 27" H (max.)  
 Max. weight (lbs.): 68  
 Description: Aluminum construction; open impeller, adjustable wear plate; rests on bottom strainer.  
 Options: SS impellers

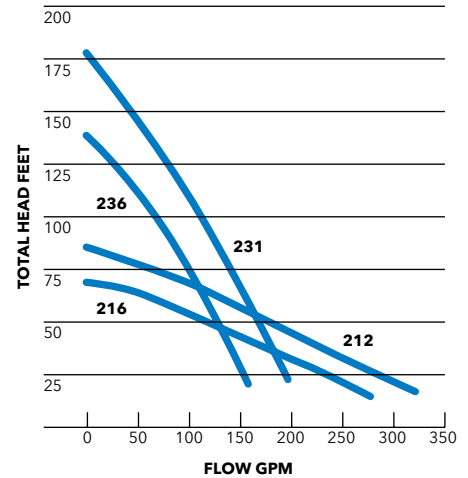

## BS 2075.324

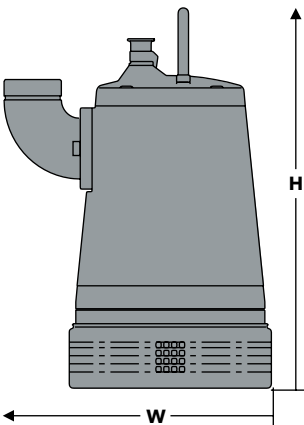

Model number: 2075.324  
 Motor rating: 3 $\emptyset$ : 5.4 HP@3425 RPM  
 8.9 HP@3410RPM  
 Voltage (3 $\emptyset$ ): 230V 460V 575V  
 Full load amps: 14/23A 7.2/12A 5.8/9.4A  
 Versions: 2" Super High head  
 Imp. Code 272  
 3" High head  
 Imp. Code 234  
 3" Standard  
 Imp. Code 232  
 Hose connection: Male NPSM threaded  
 Pump dimensions: 12" W (max.) x 22" H (max.)  
 Max. weight (lbs.): 88  
 Description: Cast iron construction, open impeller, adjustable wear plate; rests on bottom strainer

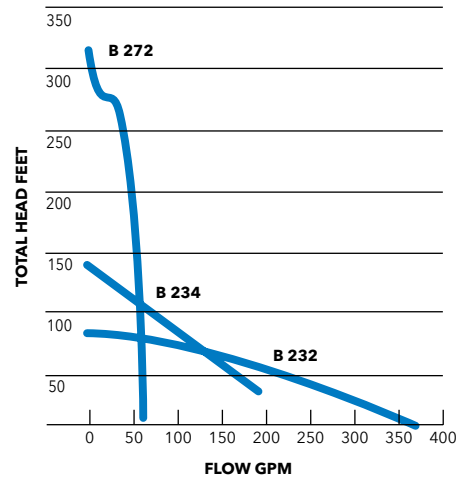

## BS 2125

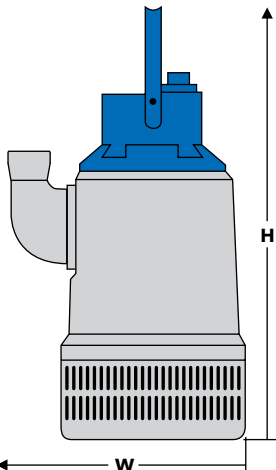

Model number: 2125.181  
 Motor rating: 13 HP@3470 RPM  
 Voltage (3 $\emptyset$ ): 230V 460V 575V  
 Full load amps: 32A 16A 13A  
 Versions: 3" High head (2 stage)  
 Imp. Code 234  
 Hose connection: Male NPSM threaded, or slip-on  
 Pump dimensions: 18" W (max.) x 33" H (max.)  
 Max. weight (lbs.): 176  
 Description: Aluminum construction; open impeller, adjustable wear plate; rests on bottom strainer.

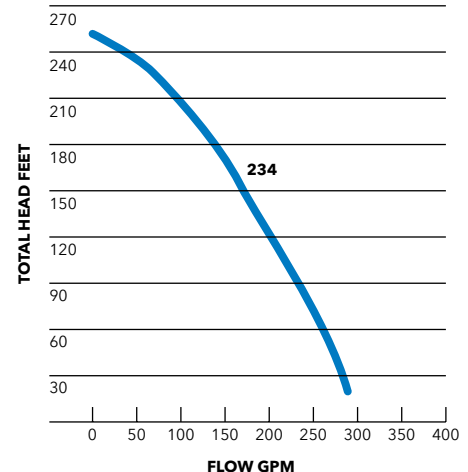

\* Cast iron version 2125.320 available.

## BS 2140

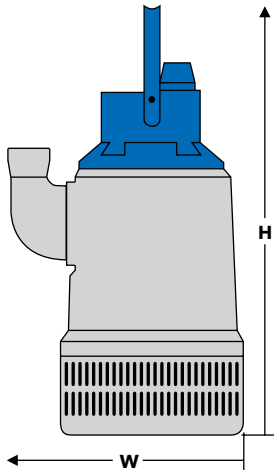

Model number: 2140.010  
 Motor rating: 19 HP@3480 RPM  
 Voltage (3 $\phi$ ): 230V 460V 575V  
 Full load amps: 46A 23A 18A  
 Versions: 3" High head (2 stage)  
 Imp. Code 234

Hose connection: Male NPSM threaded, or slip-on  
 Pump dimensions: 18" W (max.) x 33" H (max.)  
 Max. weight (lbs.): 186  
 Description: Aluminum construction; open impeller, adjustable wear plate; rests on bottom strainer.

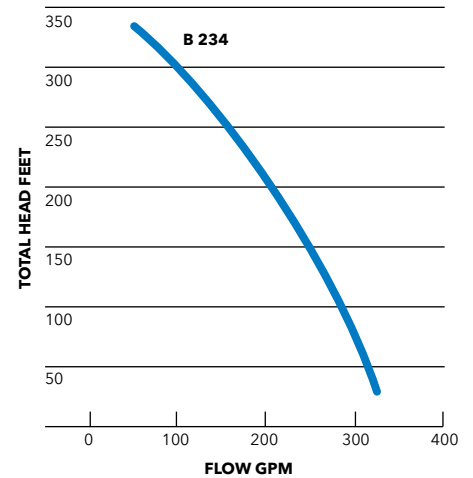

## BS 2201

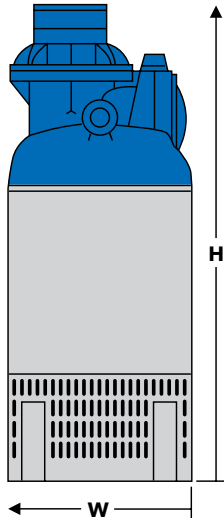

Model number: 2201.011, 2201.320  
 Motor rating: 58 HP@3450 RPM (High head, Std.)  
 50 HP@1760 RPM (High volume)\*  
 Voltage: 460V 575V  
 Full load amps: 66/65A 52/48A  
 Versions: 4" High head, Imp. Code 234, 244  
 6" & 8" Standard, Imp. Code 232  
 6" & 8" High vol., Imp. Code 412

Hose connection: 4" Male NPSM threaded  
 6" & 8" Female NPT threaded  
 Pump dimensions: 19" W (max.) x 48" H (max.)  
 Max. weight (lbs.): 617 - Aluminum, 1000 - Cast iron  
 Description: Aluminum (.011) or cast iron (.320) construction; open impeller(s), adjustable wear plate; rests on bottom strainer.

Options: SS impellers  
 2201.590 MSHA approved version.

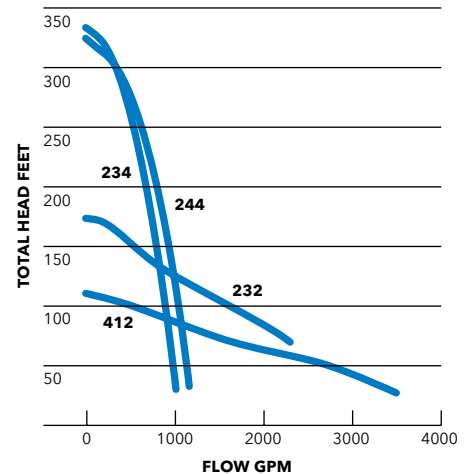

## BS 2250

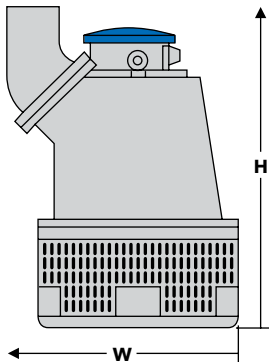

Model number: 2250.011  
 Motor rating: 87 HP@1770 RPM  
 Voltage (3 $\phi$ ): 460V 575V  
 Full load amps: 103A 83A  
 Versions: 6" High head  
 Imp. Code 434  
 8" & 10" Standard  
 Imp. Code 432

Hose connection: 6" & 8" Female NPT threaded  
 10" Male NPT threaded  
 Pump dimensions: 37" W (max.) x 49" H (max.)  
 Max. weight (lbs.): 1190  
 Description: Aluminum construction; open impeller, adjustable wear plate; rests on bottom strainer.

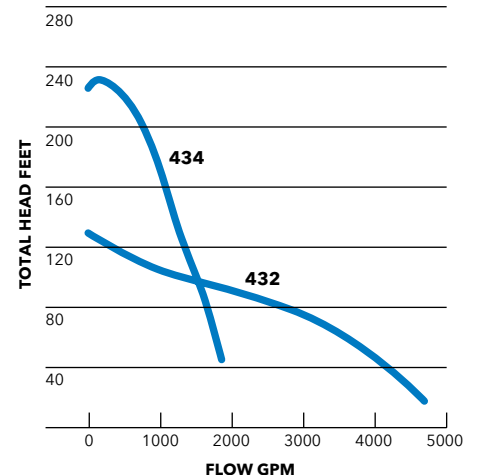

## BS 2290

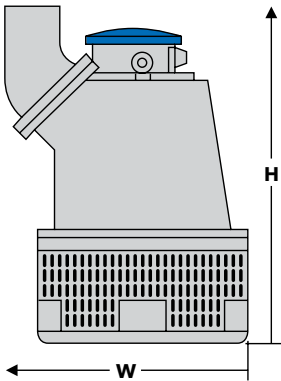

Model number: 2290.010  
 Motor rating: 110HP@1775RPM  
 Voltage (3 $\phi$ ): 460V 575V  
 Full load amps: 131A 105A  
 Versions: 6" High head  
 Imp. Code 434  
 8" & 10" Standard  
 Imp. Code 432  
 Hose connection: 6" & 8" Female NPT threaded  
 10" Male NPT threaded  
 Pump dimensions: 37" W (max.) x 49" H (max.)  
 Max. weight (lbs.): 1190  
 Description: Aluminum construction; open  
 impeller, adjustable wear plate;  
 rests on bottom strainer.

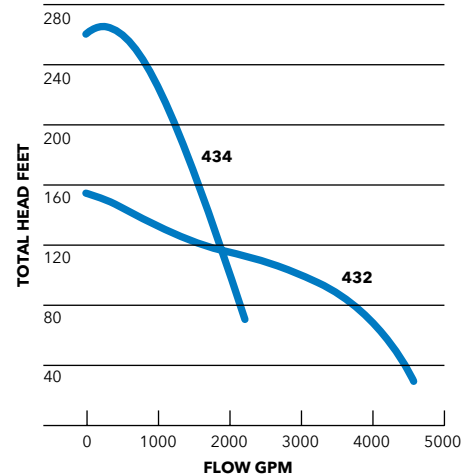

## BS 2400 HT

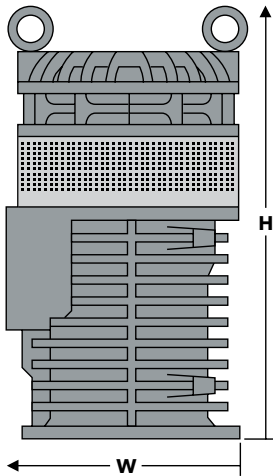

Model number: 2400.402  
 Motor rating: 140HP@3560RPM  
 Voltage (3 $\phi$ ): 460V 575V  
 Full load amps: 148A 118A  
 Versions: 4" High head  
 Imp. Code 244  
 Discharge conn.: 250# Flange  
 Pump dimensions: 27" W (max.) x 49" H (max.)  
 Max. weight (lbs.): 1984  
 Description: Cast iron construction; open (MT)  
 or closed (HT) impeller, adjustable  
 wear plates, strainer, rests on  
 bottom.  
 Options: SS impellers, SS wet end  
 2400.490 MSHA approved version.

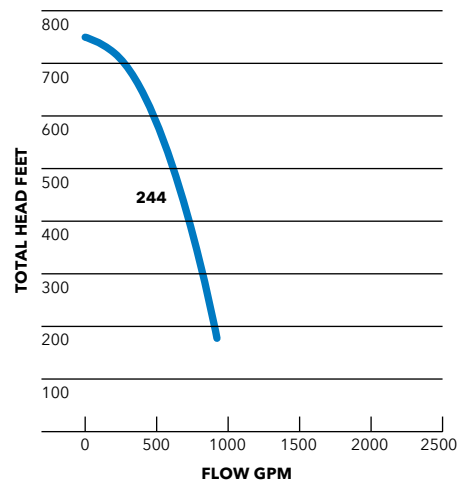

\* including stand

## BS 2400 MT

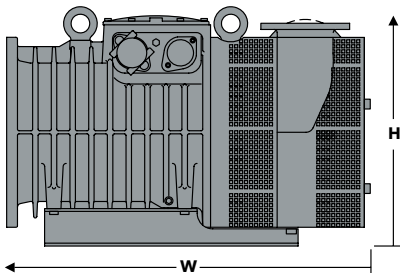

Model number: 2400.402  
 Motor rating: 140HP@3560RPM  
 Voltage (3 $\phi$ ): 460V 575V  
 Full load amps: 148A 118A  
 Versions: 4" High head  
 Imp. Code 244  
 6" High volume  
 Imp. Code 232  
 Discharge conn.: 125# Flange  
 Pump dimensions\*: 30" W (max.) x 49" H (max.)  
 Max. weight (lbs.):\* 2167  
 Description: Cast iron construction; open (MT)  
 or closed (HT) impeller, adjustable  
 wear plates, strainer, rests on  
 bottom.  
 Options: SS impellers, SS wet end  
 2400.490 MSHA approved version.

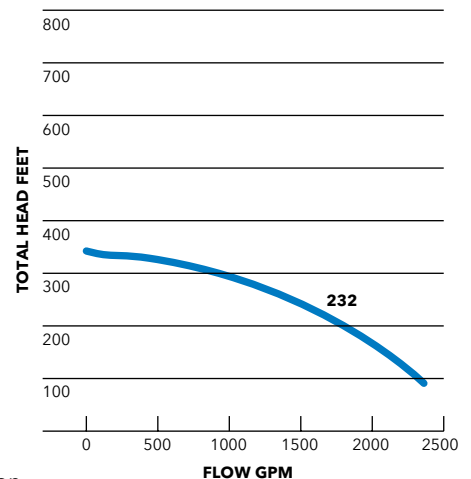

\* including stand