

PRESSURE SWITCHES FOR WATER SYSTEM APPLICATIONS



Construction

- Pressure switches for use with water in autoclave systems
- The switch ensures automatically the starting and stopping of the electric pump according to the set pressure values
- Electric contacts: normally closed and made of brass alloy with Ag-Ni surfacing
- Terminals with M4 screws and 8x8 mm pressure dice
- NBR rubber membrane with textile insert (food grade for PMAT 5M-10, PMAT 5M/T-16, PMAT 5.5M/T-16)
- 1/4" hydraulic connection made of galvanized steel
- Standard protection degree IP 44
- Max ambient temperature: 55°C
- Tear resistant cable clamps

Adjustment key included

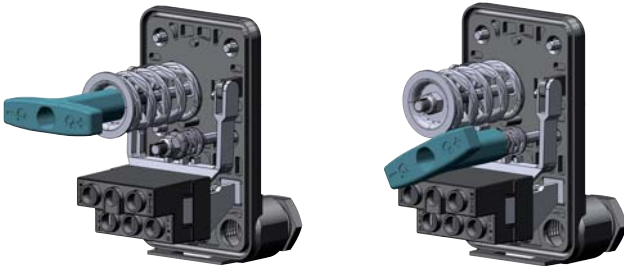

Technical data

2-pins	max A	Pressure range bar	Differential		Factory setting bar
			min bar	max bar	
PMAT 5M-10	10	1 - 5	0,6	2,3	1,4 - 2,8

Maximum rated voltage 250V

2-pins	max A	Pressure range bar	Differential		Factory setting bar
			min bar	max bar	
PMAT 5M/T-16	16	1 - 5	0,6	2,3	1,4 - 2,8
PMAT 5,5M/T-16	16	1,5 - 5,5	0,8	2,2	1,8 - 3
PMAT 12M/T-16	16	3 - 12	1,5	5	5 - 7

Maximum rated voltage 500V

Dimensions

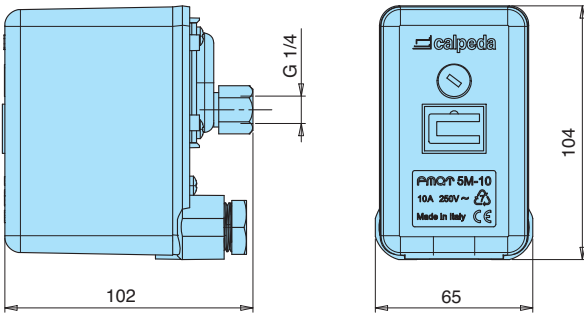

Connection diagram

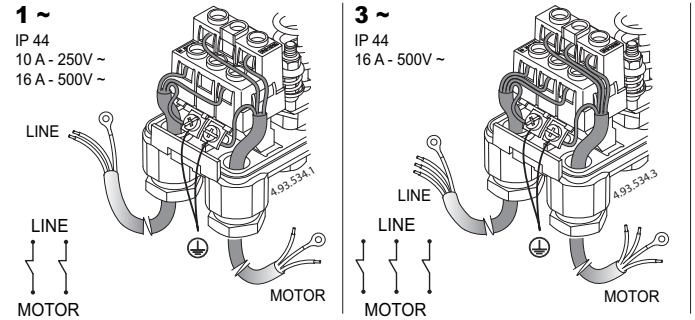

Diagram setting

