

# KPM

## POMPES DE RELEVAGE À ROUE VORTEX HAUTE RÉSISTANCE



## Pompes de relevage à roue vortex haute résistance

### Données techniques n ≈ 2900 rpm

#### Exécution

Pompe en inox 304 à roue vortex haute résistance. Pour eaux chargées avec particules abrasives.

#### Utilisations

Idéal pour le pompage de chantier BTP, carrières...

#### Limites d'utilisations

Température maxi : + 40°C.  
 Profondeur maxi d'immersion : 20 mètres.  
 Valeur de PH autorisé : de PH6 à PH 10.  
 Densité du liquide < 1,1 kg/dm.

#### Moteur

Moteur à sec 2900 tours/minute (service continu).  
 Isolation classe F.  
 Protection IP 68.

Composant	MATÉRIAUX	
	KPM 50.04 - 07	KPM 50.15 - KPM 80 - KPM 100
Corps de pompe	Inox 416	Inox 304
Turbine	Gomme nitrile	Acier chromé haute qualité
Arbre	ADC12	Inox
Etanchéité	1 garniture mécanique en carbure / carbone / FPM	
Câble d'alimentation	3 x 1 mm <sup>2</sup> en monophasé 230V 4 x 1 mm <sup>2</sup> en triphasé 400V	3 x 1,5 mm <sup>2</sup> en monophasé 230V 4 x 1 mm <sup>2</sup> - 4 x 1,5 mm <sup>2</sup> 4 x 2,5 mm <sup>2</sup> - 4 x 4 mm <sup>2</sup> en triphasé 400V selon modèle

### Courbes hydrauliques - KPM 50.04/50.07

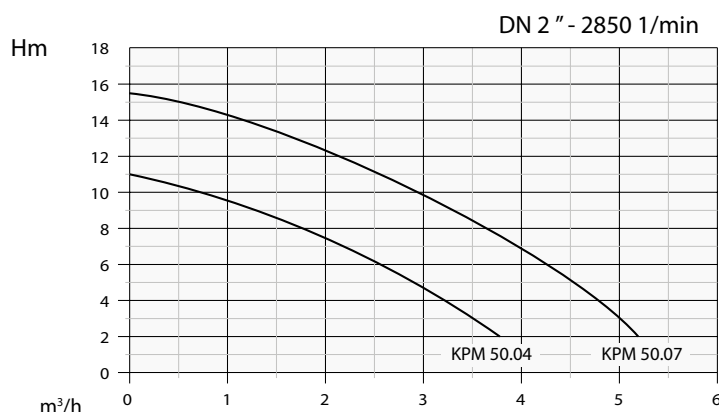

Référence	MOTEUR				Ref.	Passage en mm	Kg	m³/h l/min	1.8 30	3.6 60	7.2 120	10.8 180	12.6 210	14.4 240	18 300	21.6 360	25.2 420	28.8 480	
	Tension	KW	A	µF															
KPM 50.04T	400	0.4	1	-	2" mâle	4	13	H m	11	9	7.5	4.5	3	-	-	-	-	-	-
KPM 50.04M	230		3	12					15	14.5	12.5	10	8.5	7	3	-	-	-	
KPM 50.07T	400	0.75	2	-			16		15	14.5	12.5	10	8.5	7	3	-	-	-	
KPM 50.07M	230		5.4	20															

T = Triphasé - M = Monophasé



## Pompes de relevage à roue vortex haute résistance

### Courbes hydrauliques - KPM 50.15

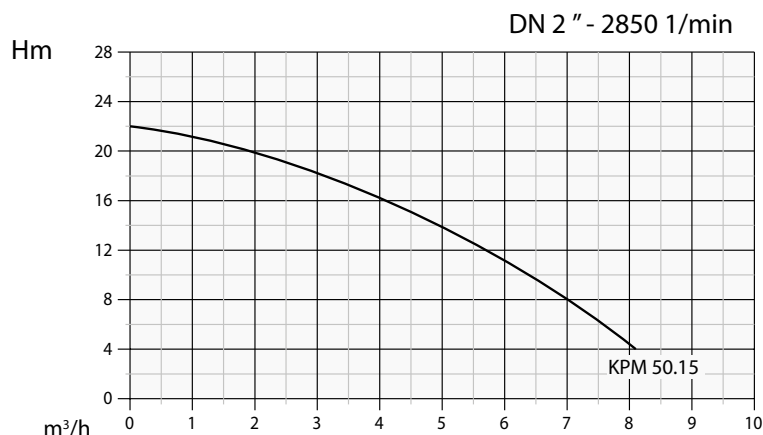

Référence	MOTEUR				Ref.	Passage en mm	Kg	m³/h l/min	1.8	3.6	7.2	10.8	12.6	14.4	18	21.6	25.2	28.8
	Tension	KW	A	µF					H m	30	60	120	180	210	240	300	360	420
KPM 50.15T	400	1.1	3.3	-	2" mâle	9	34	H m	22	21	20	18	17	16	14	11	8	4
KPM 50.15M	230		10	30					4									

T = Triphasé - M = Monophasé

### Courbes hydrauliques - KPM 80.22/80.37/100.55/100.110

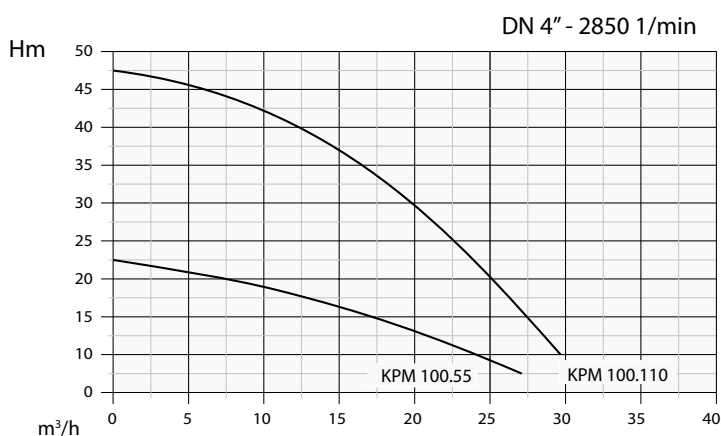
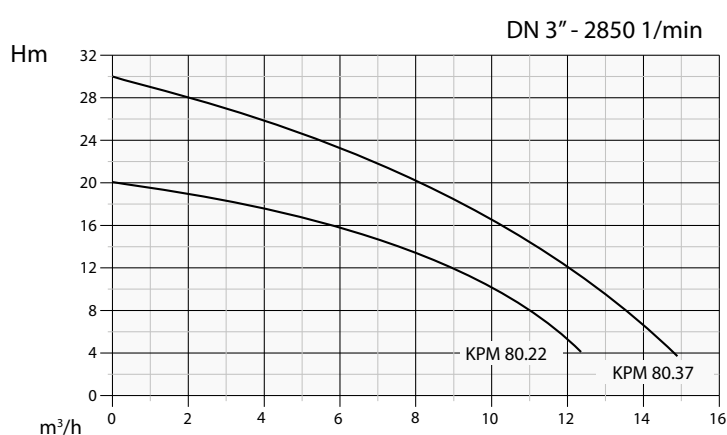

Référence	MOTEUR			Ref.	Passage en mm	Kg	m³/h l/min	3.6	7.2	9	18	27	36	43.2	54	72	90	108
	Tension	KW	A					H m	60	120	150	300	450	600	720	900	1200	1500
KPM 80.22T	400	2.20	5	3" M	9	36	H m	20	19	18.5	16.5	14	10	5	-	-	-	-
KPM 80.37T		3.70	8.3					11	45	29	28	27.5	24.5	21	17	12	4	-
KPM 100.55T		5.50	12.4	4" M	15	93		-	-	22	21	20	19	18	16	13	9	-
KPM 100.110T		11.00	24.8					-	-	47	45.5	44	42.5	40.5	37	30	20	10

T = Triphasé - M = Monophasé

## Dimensions et poids

**KPM 50.04 - 07**

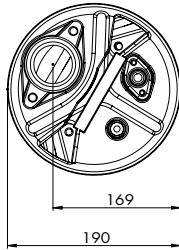
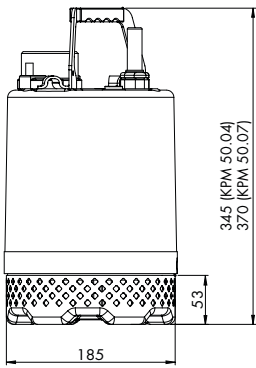

**KPM 50.15**

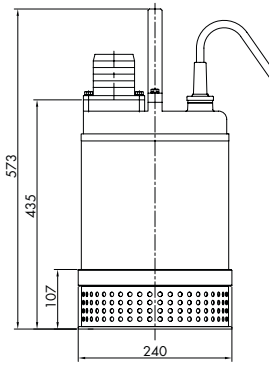

**KPM 80.22**

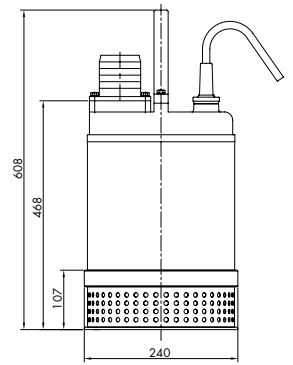

**KPM 80.37**

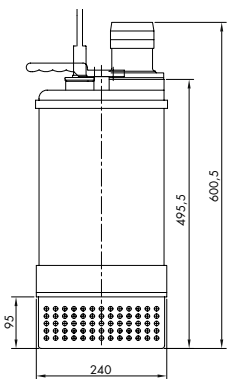

**KPM 100.55**

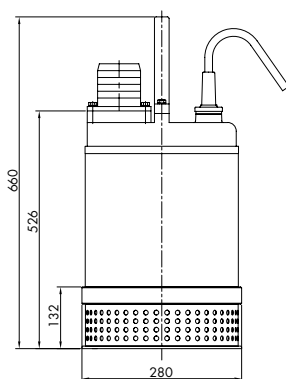

**KPM 100.110**

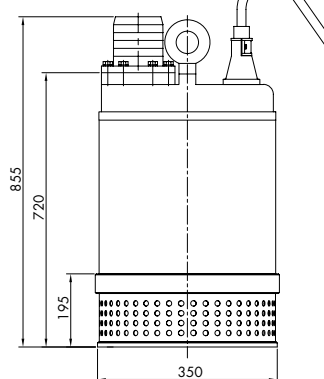

Référence	Poids en Kg
<b>KPM 50.04</b>	13
<b>KPM 50.07</b>	16
<b>KPM 50.15</b>	34
<b>KPM 80.22</b>	36
<b>KPM 80.37</b>	45
<b>KPM 100.55</b>	50
<b>KPM 100.110</b>	93

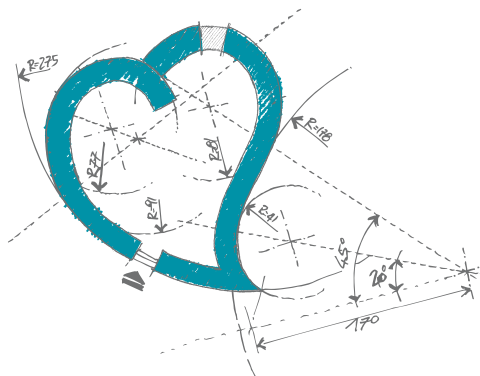

**Calpeda Pompes S.A.**

19, rue de la communauté - BP 3 - ZA La Forêt - 44140 LE BIGNON  
Tél. 02 40 03 13 30 - Fax 02 40 03 16 70 - email : info@calpeda.fr - www.calpeda.com

SA au capital de 1 030 000 € - RCS Nantes B 322 698 093 - Siret 322 698 093 00059 - Code NAF 4669B - N° TVA intra communautaire : FR50322698 093