

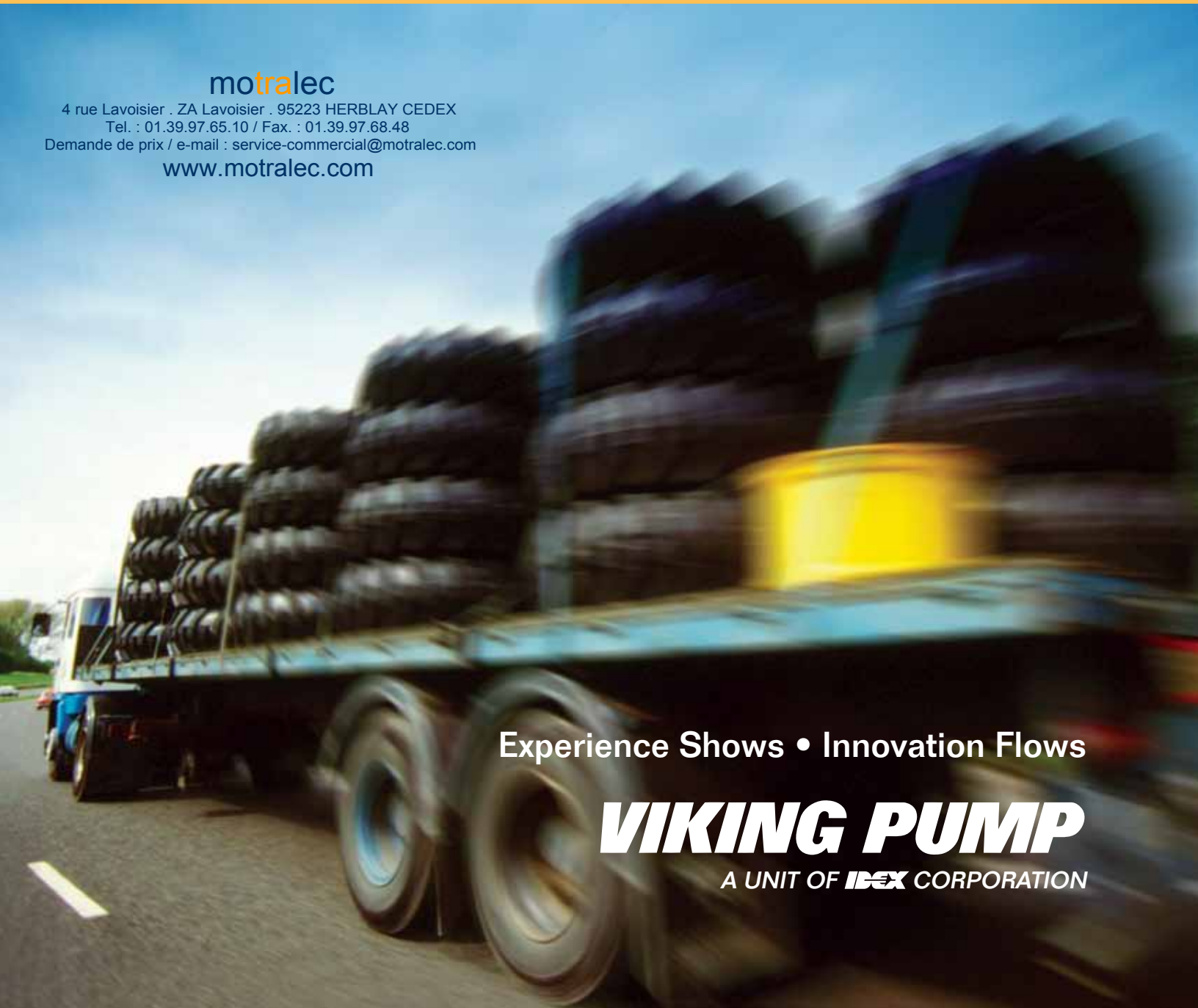

PUMPING RUBBER

motralec

4 rue Lavoisier . ZA Lavoisier . 95223 HERBLAY CEDEX
Tel. : 01.39.97.65.10 / Fax. : 01.39.97.68.48
Demande de prix / e-mail : service-commercial@motralec.com
www.motralec.com



Experience Shows • Innovation Flows

VIKING PUMP

A UNIT OF **IBEX** CORPORATION



Catalyst Pump



Rubber Cement Pump

OUR EXPERIENCE SHOWS IN...

Service to the Rubber Industries

Viking Pump's positive displacement pumping solutions gently handle shear-sensitive synthetic and natural rubber materials and additives in all stages of

production, from polymer processing to compounding to product manufacturing and recycling.

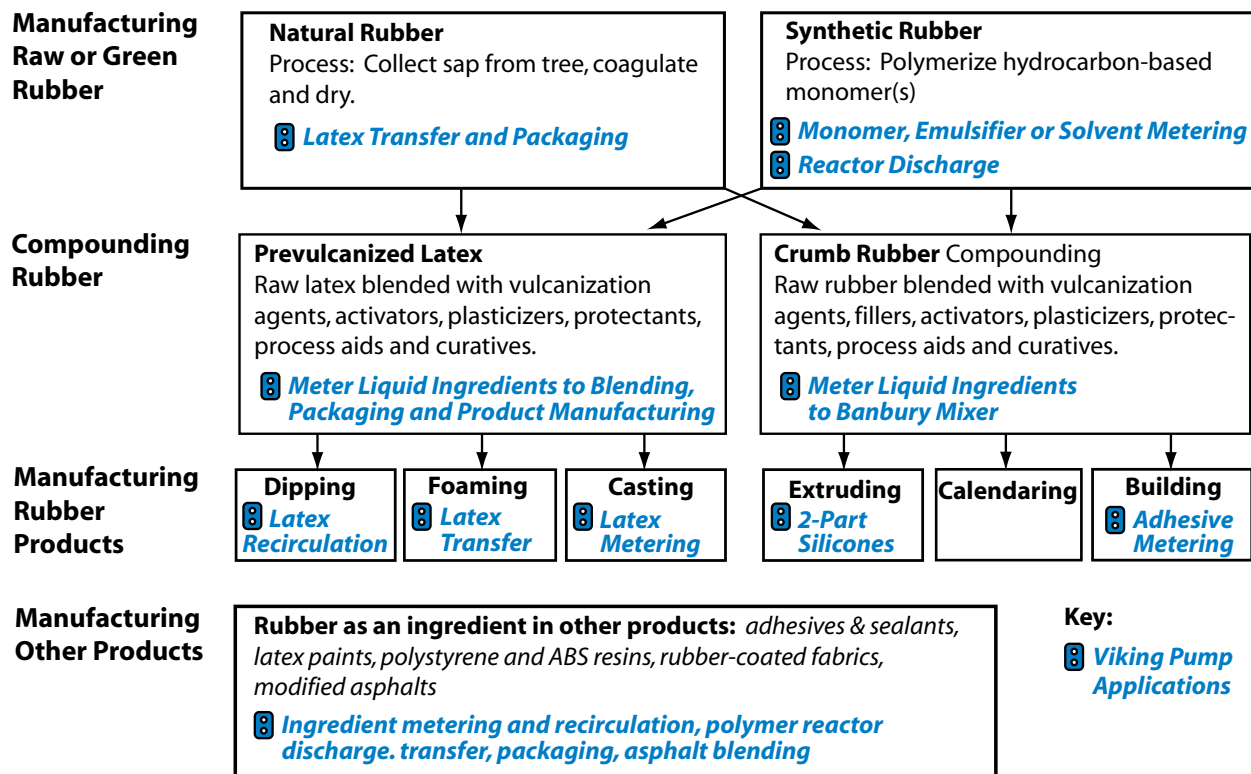

Key:
 [Icon] *Viking Pump Applications*



Synthetic Rubber Processing

Ingredient Metering: Viking® pumps are used for monomers, emulsifiers, catalysts, solvents, shortstop and other ingredients for metering into continuous processes or for batch processes.

Products:

- Viking Mag Drive® sealless internal gear pumps
- Universal Seal Series internal gear pumps

Polymer Reactor Discharge: Viking internal gear pumps are used to transfer synthetic rubber from reactor to reactor during polymerization. With enlarged top suction ports and side- or bottom-discharge ports, they are specially designed to handle both low viscosity solvents and high viscosity polymers.

Products:

- Universal Seal Series internal gear pumps

Polymer Processing Pumps

Viking Pump's extensive experience and engineering expertise in polymer processing ensures long-term reliability and product quality in reactor feed and discharge applications. Viking internal gear pumps offer these benefits:

- *Slow speed operation to minimize liquid shear to protect product integrity and maximize shaft seal life.*
- *High-speed operation allows complete solvent flushing for superior clean-in-place capabilities.*

- *Broadest choice of shaft seals and seal plans or sealless mag-drive designs.*
- *Widest selection of porting, up to 14-inch, in 180° (straight through) or 90° configurations.*
- *Integral heating/cooling jacketing in the bracket, casing, head and flanges to allow total temperature control within the pump.*





Natural Rubber



Dipping



Molding

OUR EXPERIENCE SHOWS IN...

Natural Rubber Processing

Viking® internal gear pumps and lobe pumps are used for transfer and packaging of natural rubber latex at the production sites, as well as at downstream application sites.

Products:

- Universal Seal Series internal gear pumps
- Industrial Lobe Series pumps

Compounding

Viking Universal Seal internal gear and external gear pumps provide accurate metering of liquid ingredients or liquid latex into mixers.

Products:

- Universal Seal Series internal gear pumps
- SG Series external gear pumps

Product Manufacturing

Latex Recirculation

Dipping applications call for gentle latex recirculation with low shear and minimal pulsation. Viking gear pumps and lobe pumps are used extensively, offering low cost of operation and minimal pulsation.

Products:

- Universal Seal Series internal gear pumps
- Industrial Lobe Series pumps

Fabric Application

Viking gear pumps and lobe pumps are used to deliver rubber solutions for rubberizing fabrics.

Products:

- Universal Seal Series internal gear pumps
- Industrial Lobe Series pumps

Building

Tire manufacturers rely on Viking for rubber cement and adhesive metering.

Products:

- Universal Seal Series internal gear pumps.
- Industrial Lobe Series pumps



Spandex / Elastane Pump



ABS Resin Reactor Pump



Rubber-Modified Asphalt Pump

Foam Rubber

Viking® gear pumps and lobe pumps are used to meter latex to foaming operations.

Products:

- Universal Seal Series internal gear pumps
- Industrial Lobe Series pumps

Two-Part Products

For two-part liquid silicones as well as polyurethanes, Viking external gear pumps offer capacities to 46 m³/hr (200 gpm) at pressures to 172 bar (2500 psi), in sealed or mag drive configurations, to meter the components and to inject them into molds.

Products:

- SG Series external gear pumps

Rubber-Modified Products

For both processing and application of latex paints, adhesives and sealants, polystyrene, ABS resin, modified asphalt, and many other products containing natural or synthetic rubbers, Viking gear pumps and lobe pumps are used extensively.

Products:

- Universal Seal Series internal gear pumps
- Industrial Lobe Series pumps

Recycling

Viking pumps are used to handle rubber-modified asphalts both at the refinery and at hot mix plants, and to pump ground rubber in solution to manufacture recycled rubber products like playground mats.

Products:

- Universal Seal Series internal gear pumps
- Industrial Lobe Series pumps

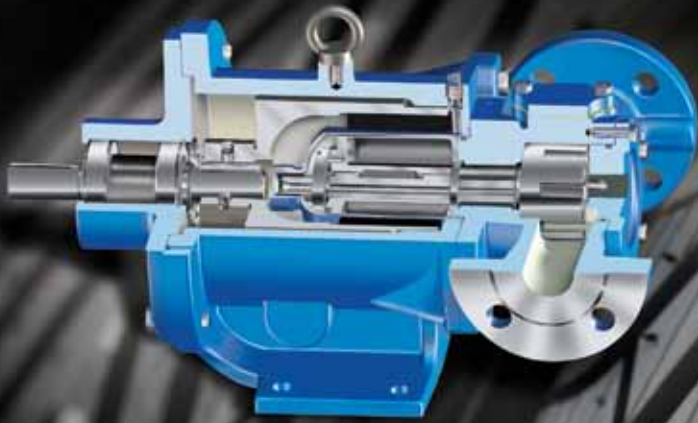

Viking Mag Drive® Internal Gear Pumps

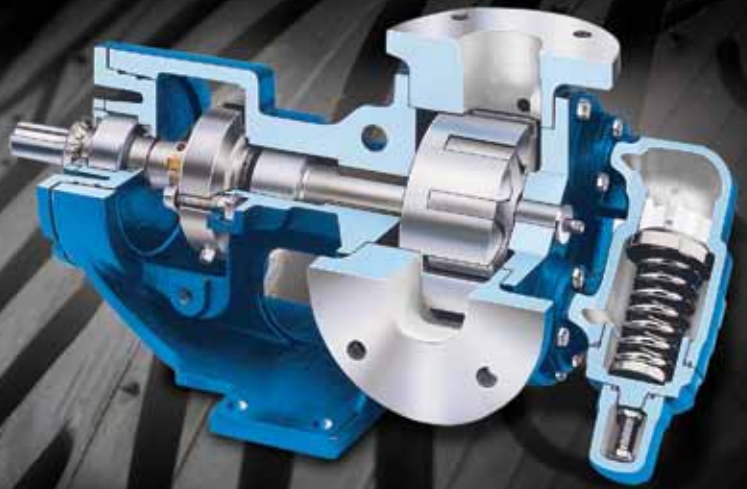

Universal Seal Internal Gear Pumps

OUR EXPERIENCE SHOWS IN...

Viking® Benefits

Low shear - Viking pumps operated at low speeds minimize liquid shear and protect the product integrity.

Ability to handle thin or thick liquids - the same Viking pump can handle solvents less than 10 cSt or polymers more than 440,000 cSt.

Shaft sealing - when handling sticky, volatile or hazardous liquids, Viking offers a broad array of shaft sealing solutions, including the Viking Mag Drive.

Temperature - handling hazardous liquids requires materials of construction that are not susceptible to thermal cracking, like stainless steel, steel or ductile iron. Viking offers the material options and a variety of jacketing options needed to maintain and control temperatures during the rubber manufacturing process.

Customizability - Viking pumps can be easily customized with thousands of options for materials, porting and sealing, to ensure that each pump is optimized for the material and the application.

Viking Pumps for Rubber Applications

Viking Mag Drive® Sealless Internal Gear Pumps

- Applications: Monomers and solvents
- Capacities to 114 m³/hr (500 gpm)
- Pressures to 14 bar (200 psi)
- Temperatures to 260°C (500°F)
- Stainless steel, steel, ductile iron or cast iron construction
- 16 Displacements available

Viking Mag Drive Sealless External Gear Pumps

- Applications: Monomers and solvents
- Capacities to 45 m³/hr (200 gpm)
- Pressures to 170 bar (2,500 psi)
- Temperatures to 230°C (450°F)
- Ductile iron or cast iron construction
- 30 Displacements available



Industrial Lobe Pumps

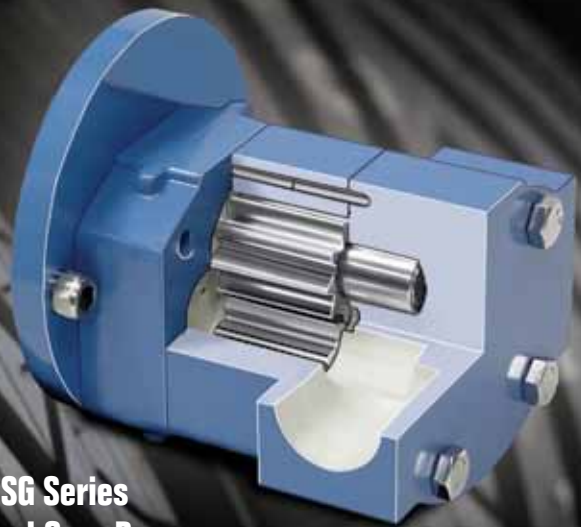

**SG Series
External Gear Pumps**

Universal Seal Internal Gear Pumps

- Applications: Monomers, solvents, emulsifiers, additives, polymers, liquid latex, rubber emulsions and solutions, latex paints, adhesives and sealants, modified asphalts
- Capacities to 340 m³/hr (1,500 gpm)
- Pressures to 20 bar (280 psi)
- Temperatures to 420°C (700°F)
- Stainless steel, steel, ductile iron or cast iron construction
- Component or cartridge-style shaft seals
- Jacketing options for temperature control
- Enlarged suction ports for viscous polymers.
- 12 Displacements available

Industrial Lobe Series Timed Lobe Pumps

- Applications: Emulsifiers, additives, polymer (reactor discharge), liquid latex, rubber emulsions and solutions, latex paints, adhesives and sealants
- Capacities to 184 m³/hr (820 gpm)
- Pressures to 27 bar (400 psi)
- Temperatures to 205°C (400°F)
- Stainless steel construction, steam cleanable
- Component or cartridge-style shaft seals
- 18 Displacements available

Spur Gear (SG) Series External Gear Pumps

- Applications: Metering liquid additives to reactor or mixer, metering two-part liquid silicones or polyurethanes
- Capacities to 45 m³/hr (200 gpm)
- Pressures to 170 bar (2,500 psi)
- Temperatures to 230°C (450°F)
- Ductile iron or cast iron construction
- Lip seals, component-style mechanical seals
- 33 Displacements available

For more information on these pumping principles, contact your local authorized Viking Distributor.

Innovation and Experience

Viking Pump has been a pump industry leader and innovator since its founding in 1911. We continue to build on our ever growing experience delivering innovative new pumping solutions, including custom designs, to many thousands of customers who use millions of Viking® pumps in some of the world's toughest applications.

Broad Performance Range

Capacity:

0.5 to 360 M³/Hr (0.1 to 1,600 GPM)

Pressure:

0 to 172 Bar (0 to 2,500 PSI)

Temperature:

-40°C to 370°C (-40°F to 700°F)

Viscosity:

0.5 to 1,000,000 cSt (28 to 4,500,000 SSU)

Ultimate in Sealing Solutions

Viking's offering of packing, component mechanical seals, cartridge seals, and sealless Mag Drive technology provides the best choices for sealing flexibility needed to provide your application a customized sealing solution every time - saving you money, time, and unplanned downtime.

Material Options Matched to Application

Viking's dedicated iron and alloys foundries provide pump construction materials from cast iron to Alloy C. Application-specific materials of construction extend pump life significantly, while reducing maintenance and unplanned downtime, which enables increased production and a better bottom line.

Liquid Integrity Protection

Viking has developed multiple positive displacement pump principles to protect shear-sensitive liquids, and low-shear options to prevent damage to fibers, polymers, and solids. Full-jacketing options provide precise temperature control throughout the pump. The Viking Mag Drive® and other seal options prevent fluid contact with air, assuring liquid integrity.

Local Applications and Engineering Support

Over 245 Authorized Viking Pump Distributors in 68 countries provide local application support and service, backed by Viking Application Engineers and Viking Region Managers strategically located around the world.

Quality Manufacturing

Viking uses ISO9001-2000, Six-Sigma, and Lean/Kaizen in its worldwide manufacturing and assembly processes to remove waste, reduce development costs, and deliver superior products on schedule. Dedicated Viking foundries and manufacturing facilities utilize state-of-the-art CNC equipment to assure unmatched quality is built into every pump.

Custom Designed Solutions

Viking has provided custom designed pumps to end-users and OEMs since its first pump in 1911, when Viking invented the gear-within-a-gear pumping principle to remove water from a rock quarry. Today, enabled by Viking's engineering staff, extensive applications experience, and in-house foundries, more than 20% of Viking's sales are new Viking designs, or pumps designs derived from more than 1,000 Viking catalog pumps with more than 40,000 active configurations. So, whether you are an end-user or an OEM, Viking can provide custom designed pumping solutions to meet your specific needs.