



JOHNSON PUMP
AN SPX BRAND

CombiWell

Sump pump for paint spraying cabins
and solvent degreaser units



motralec

4 rue Lavoisier . ZA Lavoisier . 95223 HERBLAY CEDEX
Tel. : 01.39.97.65.10 / Fax. : 01.39.97.68.48

Demande de prix / e-mail : service-commercial@motralec.com

www.motralec.com

SPX[®]

The best solution to do it well.

The CombiWell is a range of specialised immersion pumps, used in water curtain paint spray booths and solvents degreasing spray units.

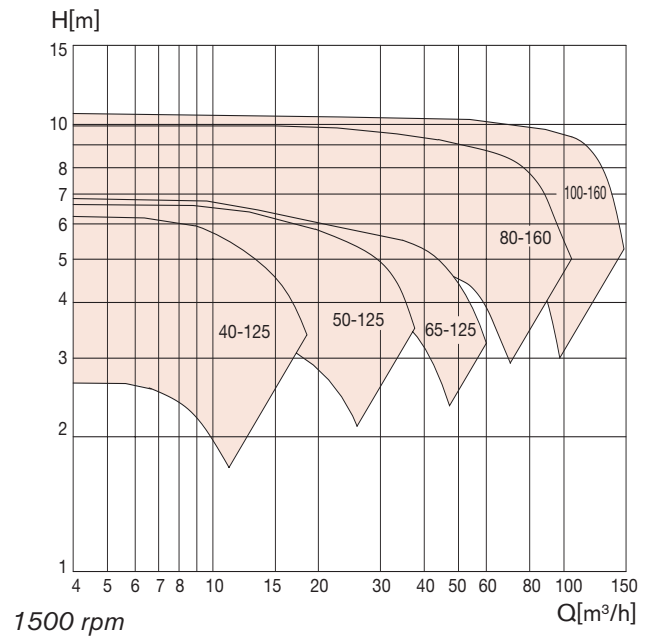

Typical characteristics

- No shaft sealing
- Liquid lubricated slide bearing
- Compact and modular design
- High degree of interchangeability between parts of different pump sizes

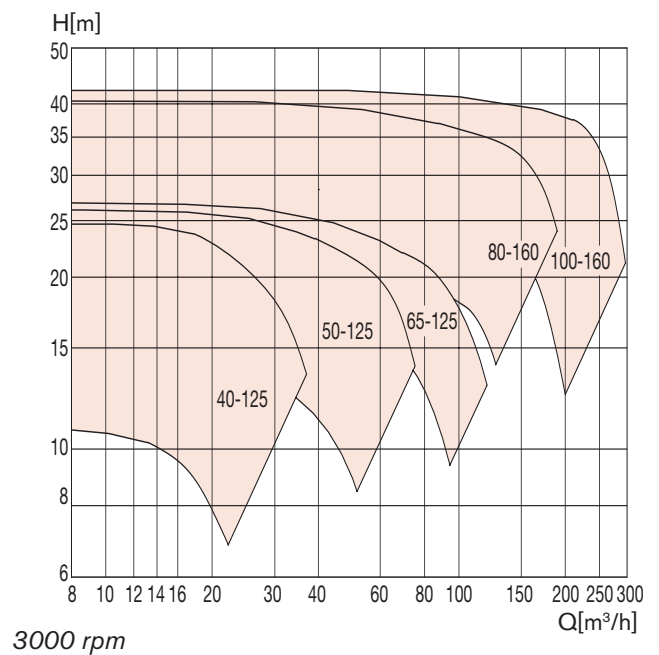

Photo courtesy: Glasbeek finish b.v.

- Water curtain paint spray booths
- Solvents degreasing spray units

Features and *benefits*

Lantern piece

- cast iron
- reducing flanges applied at motor side
- *rigid construction*
- *fits a wide range of electric motors*

Ball bearing

- located in lantern piece
- grease lubricated
- *easily replaceable*
- *low maintenance costs*

Pump casing

- permanently submerged into the liquid
- stainless steel for street cleaning version
- cast iron for paint spray version
- *always ready for action*
- *corrosion resistant*
- *cost effective materials*

Slide bearing

- located in pump cover
- shaft sleeve on shaft
- different type of bearing materials
- *lubricated by the liquid*
- *low maintenance costs*

Impeller

- stainless steel for street cleaning version
- cast iron for paint spray version
- fitted with extra large clearance between impeller and pump casing
- *corrosion resistant*
- *cost effective materials*
- *easily replaceable*

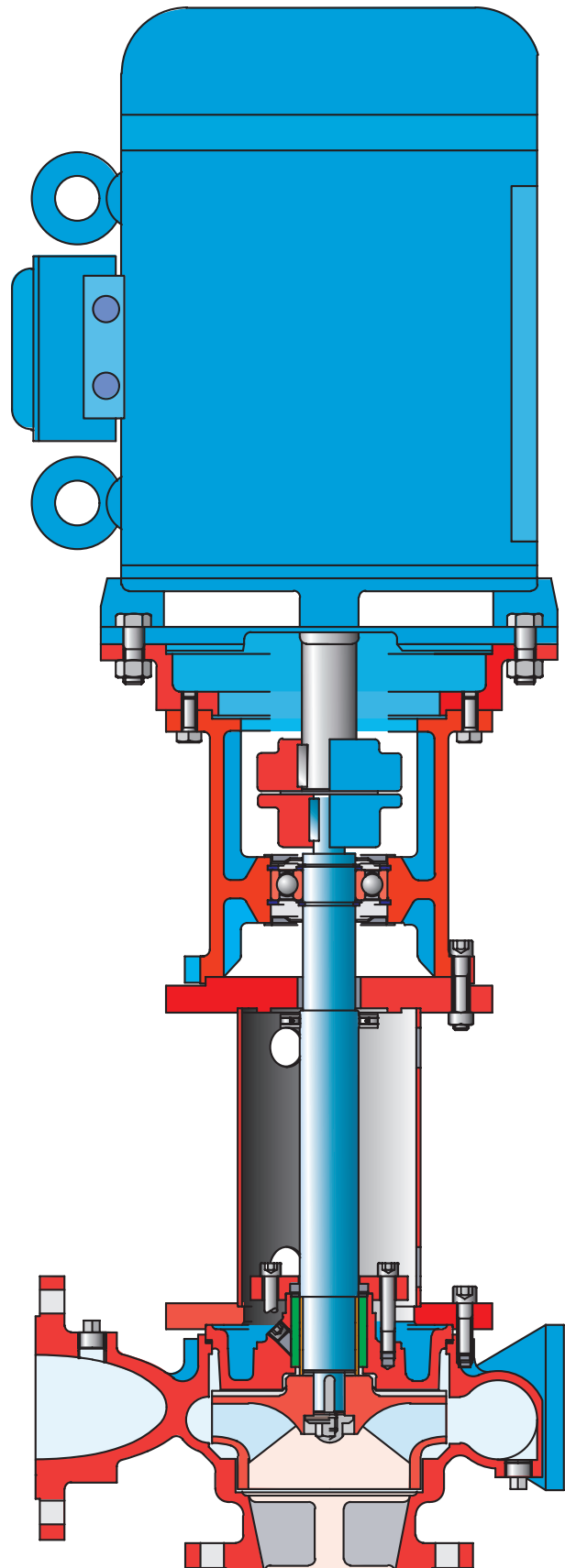

SPX[®]
WHERE IDEAS MEET INDUSTRY

motralec

4 rue Lavoisier . ZA Lavoisier . 95223 HERBLAY CEDEX
Tel. : 01.39.97.65.10 / Fax. : 01.39.97.68.48
Demande de prix / e-mail : service-commercial@motralec.com
www.motralec.com

