



HYDRA-TECH PUMPS

PORTABLE HYDRAULIC POWER UNIT

MODEL HT60DJV



Unit shown with optional hydraulic brakes and lighting kit

This popular unit features a John Deere diesel engine and pressure compensated hydraulic pump for maximum versatility and enhanced performance when driving our submersible pumps.

FEATURES

- Highway Trailer Chassis with built-in extended-run fuel tank and independent suspension
- Single Point Lifting Bracket and Tie Downs for Transport
- Automatic Engine Safety Shutdown
- Variable Piston Hydraulic Pump
- Efficient Hydraulic Oil Cooler
- Spin-On Return Filter w/Indicator
- Variable Speed Control
- Tank Top Filler/ Strainer
- System Relief Valve
- Pressure Control Valve
- Liquid Filled Pressure Gauge
- Fluid Level/ Temperature Gauge

OPTIONS

- D.O.T. Brakes and Lights
- Skid Frame
- Multiple Hydraulic Circuits
- Other Flow and Pressure Combinations

B0109



motralec

4 rue Lavoisier . ZA Lavoisier . 95223 HERBLAY CEDEX
Tel. : 01.39.97.65.10 / Fax. : 01.39.97.68.48

Demande de prix / e-mail : service-commercial@motralec.com

www.motralec.com

Model HT60DJV Overall Dimensions

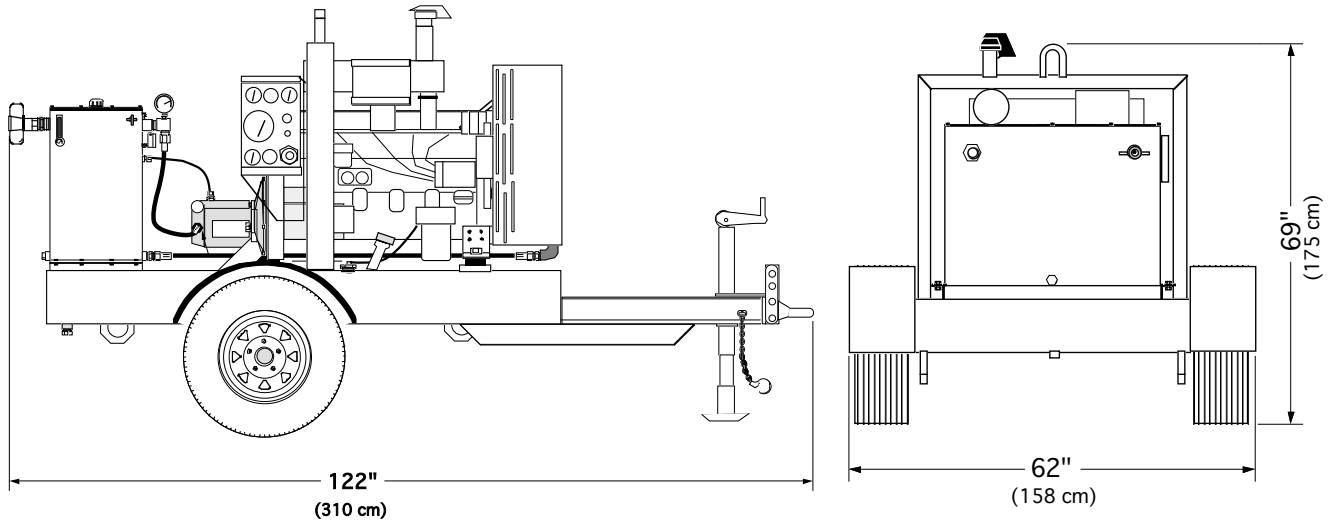

SPECIFICATIONS

ENGINE:..... John Deere 4045T280 Diesel (Tier 3)
HORSE POWER:..... 72 @ 2300 RPM
HYDRAULIC OUTPUT*:..... Variable Max 26 GPM (98 LPM)
OPERATING PRESSURE*:..... Maximum 2900 PSI (197 Bar)
HOSE PORT SIZE:..... 1" NPT
HYDRAULIC OIL:..... SAE 10W or 20W Type AW
also: Biodegradable oil (Consult Factory)
OIL FILTRATION:..... 10 Micron (Standard)
OIL RESERVOIR CAPACITY:..... 50 U.S. Gallons (190 Liters)
FUEL TANK CAPACITY:..... 81 U.S. Gallons (307 Liters)
FUEL CONSUMPTION:..... Approx. 2.8 U.S. Gal/Hr (10.6 Liters/Hr)
DIMENSIONS:..... H 69" (175 cm) x W 62" (158 cm) x L 122" (310 cm)
WEIGHT (Dry):..... 2460 lbs. (1114 kg)

* For Flows and Pressures Other Than Standard, Consult Factory

Since we are constantly working to improve our products, specifications are subject to change without notice.