

## PORTABLE HYDRAULIC POWER UNIT



This 100 HP unit features a turbocharged Deutz air cooled diesel and pressure compensated hydraulic pump for enhanced performance when driving our submersible pumps or other hydraulic equipment requiring flows to 53 GPM.

### FEATURES

- Proven Deutz Air Cooled Diesel Engine
- Highway Trailer Chassis with Built In Fuel Tank and Independent Suspension
- Single Point Lifting Bracket and Transport Tie Down Brackets
- Automatic Engine Safety Shutdown Package
- High Efficiency Piston Hydraulic Pump
- Variable Speed Control
- Engine Mounted Hydraulic Oil Cooler
- Spin-On Return Filter with Indicator
- System Relief Valve
- Pressure Control Valve
- Fluid Level/ Temperature Gauge

### OPTIONS

- Optional Skid Frame
- Multiple Hydraulic Circuits
- Other Flow and Pressure Combinations

B0999

## Model HT100DCV Overall Dimensions

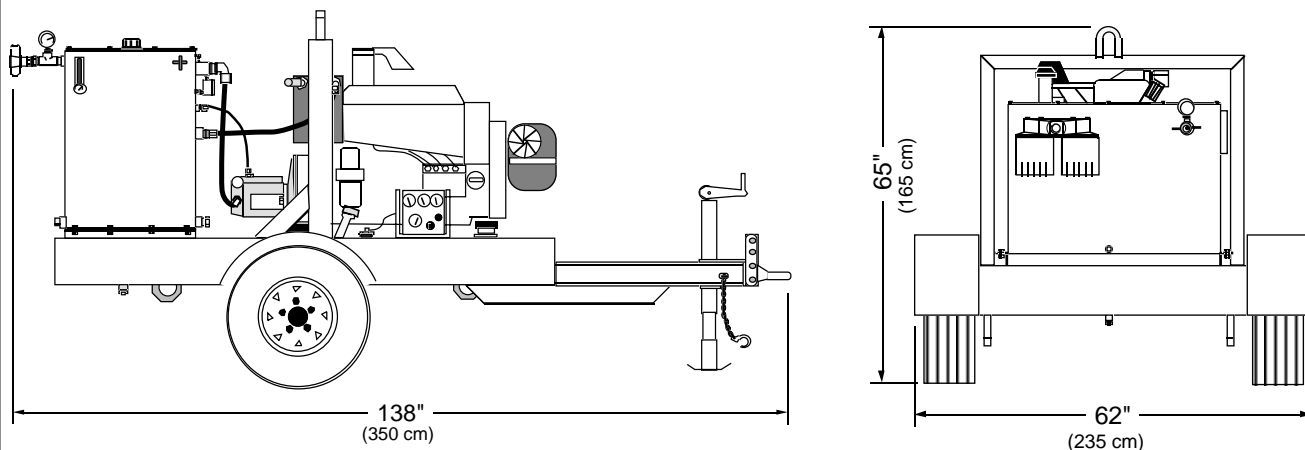

## SPECIFICATIONS

ENGINE:.....Deutz BF4L913 Air Cooled Diesel  
HORSEPOWER:.....100 @ 2300 RPM  
HYDRAULIC OUTPUT\*:.....Variable, Max. 53 GPM (201 LPM)  
OPERATING PRESSURE\*:.....Maximum 2500 PSI (201 Bar)  
HOSE PORT SIZE:.....1 1/4" NPT  
HYDRAULIC OIL:.....SAE 10W or 20W Type AW  
also: .....Bio-degradeable oil (Consult Factory)  
OIL FILTRATION:.....10 Micron (Standard)  
OIL RESERVOIR CAPACITY:.....70 U.S. Gallons (265 Liters)  
FUEL TANK CAPACITY:.....53 U.S. Gallons (200 Liters)  
FUEL CONSUMPTION:.....Approx. 3 U.S. Gal/Hr (11.3 Liters/Hr)  
DIMENSIONS:.....H 65" (165 cm) x W 62" (158 cm) x L 138" (351 cm)  
WEIGHT (Dry):.....2590lbs. (1173 kg)

Since we are constantly working to improve our products, specifications are subject to change without notice.