



HYDRA-TECH PUMPS

PORTABLE HYDRAULIC POWER UNIT

MODELS HT20G and HT20GV



This power unit features a 24 HP Honda OHV gas engine, extended run fuel tank, extra oil cooling and easy handling. It is available with a fixed displacement gear pump or pressure compensated piston pump. Great for continuous duty applications powering our pumps or other hydraulic tools and equipment.

FEATURES

- Reliable Honda Gas Engine with Oil-Alert™ Safety Shutdown
- Roll Cage Frame with Single Point Lifting Eye
- Gear-Type Hydraulic Pump (HT20G)
- Pressure Comp. Piston Pump (HT20GV)
- Variable Speed Control Lever
- Hydraulic Oil Cooler with Thermostatic Fan Control
- Quick - Disconnect Hose Couplings
- System Relief Valve
- Pressure Control Valve
- Tank Top Filler/ Strainer
- Liquid Filled Pressure Gauge
- Spin-On Return Filter W/ Indicator
- Fluid Level and Temperature Gauges

OPTIONS

- Other Flow and Pressure Combinations

E0309



motralec

4 rue Lavoisier . ZA Lavoisier . 95223 HERBLAY CEDEX
Tel. : 01.39.97.65.10 / Fax. : 01.39.97.68.48

Demande de prix / e-mail : service-commercial@motralec.com

www.motralec.com

Model HT20G / GV Overall Dimensions

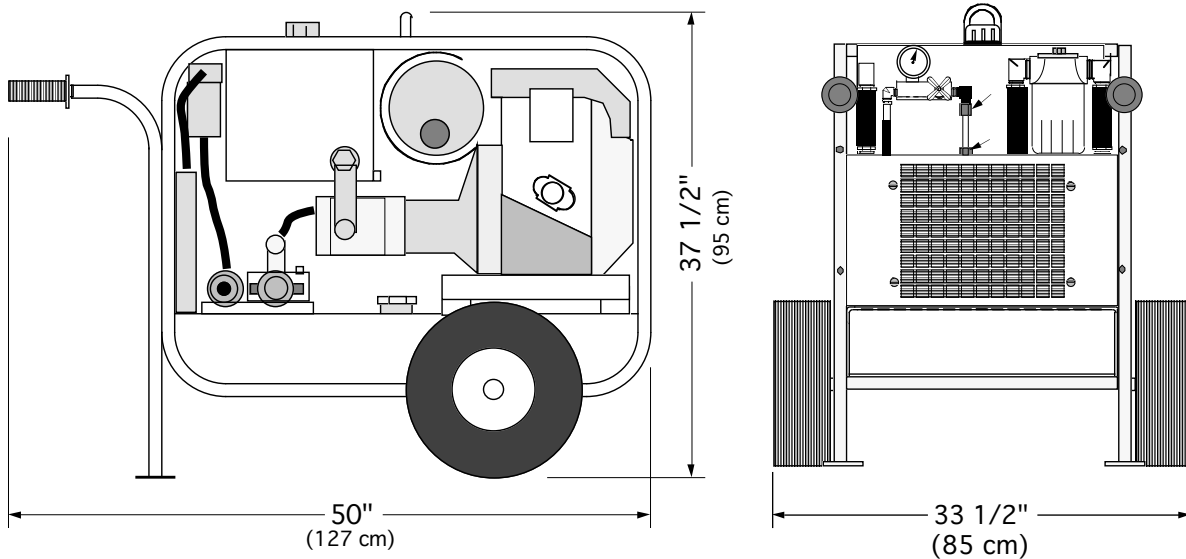

SPECIFICATIONS

ENGINE:	Honda GX670 Gasoline (Petrol)
HORSEPOWER:	24 @ 3500 RPM
HYDRAULIC OUTPUT:	Variable, Max. 12 GPM (45 LPM)
OPERATING PRESSURE:	Maximum 2500 PSI (170 Bar)
HOSE PORT SIZE:	3/4" NPT
HYDRAULIC OIL:	SAE 10W or 20W Type AW also: Dexron ATF or Biodegradable Oil (Consult Factory)
OIL FILTRATION:	10 Micron (Standard)
OIL RESERVOIR CAPACITY:	8 Gallons (30 Liters)
FUEL TANK CAPACITY:	15 Gallons (57 Liters)
FUEL CONSUMPTION:	Approx. 1.5 Gal/Hr (5.7 Liters/Hr)
DIMENSIONS:...	H 37 1/2" (95 cm) x W 33 1/2" (85 cm) x L 50" (127 cm)
WEIGHT (Dry):	(HT20G) 450 lbs. (204 kg) (HT20GV) 470 lbs. (213 kg)

* For Flows and Pressures Other Than Standard, Consult Factory

Since we are constantly working to improve our products, specifications are subject to change without notice.