



HYDRA-TECH PUMPS

PORTABLE HYDRAULIC POWER UNIT

MODEL HT25DYS



The HT25DYS power unit is driven by a Yanmar Diesel engine and is designed to drive several of our pump models including the S3CML, S3VHL, S4T, S4CSL and S8M. A large, built-in fuel tank allows this unit to run up to 24 hours between refills. Other hydraulic tools and equipment may also operate from this power unit.

FEATURES

- Highway Trailer Chassis with Built-In Fuel Tank and Independent Suspension
- Single Point Lifting Bracket
- Automatic Engine Safety Shutdown
- Vane-Type Hydraulic Pump
- Hydraulic Oil Cooler
- Variable Speed Control
- Spin-On Return Filter W/ Indicator
- Tank Top Filler/ Strainer
- System Relief Valve
- Pressure Control Valve
- Liquid Filled Pressure Gauge
- Fluid Level/ Temperature Gauge

OPTIONS

- Skid Frame
- Multiple Hydraulic Circuits
- Other Flow and Pressure Combinations

D0209



motralec

4 rue Lavoisier . ZA Lavoisier . 95223 HERBLAY CEDEX

Tel. : 01.39.97.65.10 / Fax. : 01.39.97.68.48

Demande de prix / e-mail : service-commercial@motralec.com

www.motralec.com

Model HT25DYS Overall Dimensions

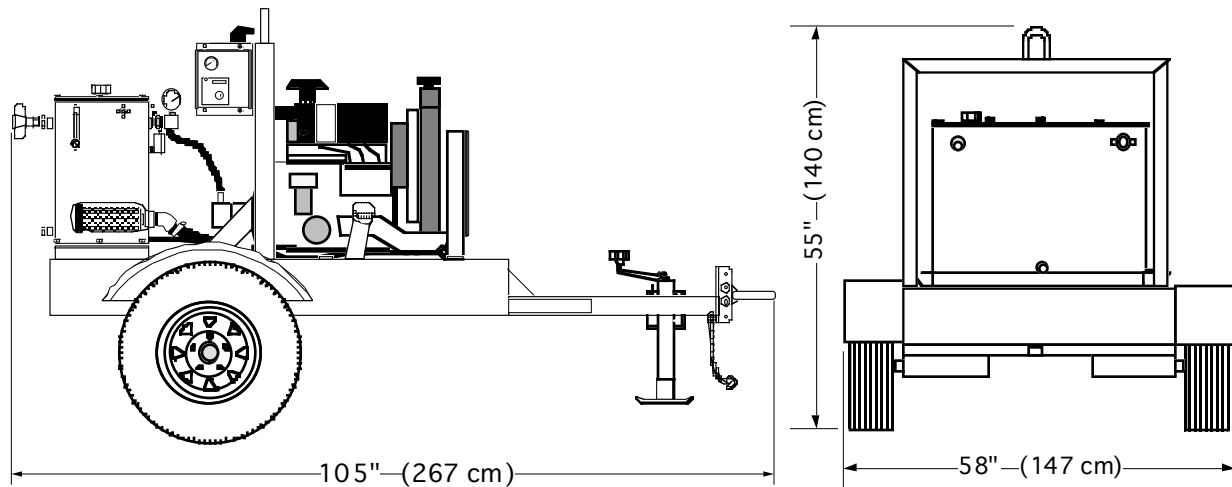

SPECIFICATIONS

ENGINE:..... Yanmar 3TNV76 Liquid Cooled Diesel (Tier 4 Int.)
POWER:..... 25 HP(19 KW) @ 3000 RPM
HYDRAULIC OUTPUT*..... Variable, Max. 14 GPM (53 LPM)
OPERATING PRESSURE*..... Maximum 2500 PSI (170 Bar)
HOSE PORT SIZE:..... 3/4" NPT
HYDRAULIC OIL:..... SAE 10W or 20W (ISO 32 or 46) Type AW
..... also: Biodegradable oil (Consult Factory)
OIL FILTRATION:..... 10 Micron (Standard)
OIL RESERVOIR CAPACITY:..... 30 U.S. Gallons (113 Liters)
FUEL TANK CAPACITY:..... 42 U.S. Gallons (159 Liters)
FUEL CONSUMPTION:..... Approx. 1.5 U.S. Gal/Hr (5.7 Liters/Hr)
DIMENSIONS:..... H 55" (140 cm) x W 58" (147 cm) x L 105" (267 cm)
WEIGHT (Dry):..... 1320 lbs. (598 kg)

* For Flows and Pressures Other Than Standard, Consult Factory

Since we are constantly working to improve our products, specifications are subject to change without notice.