



HYDRA-TECH PUMPS

PORTABLE HYDRAULIC POWER UNIT

MODEL HT13G

This Honda powered gas power pack is ideal for driving our 3" trash pump and even our 6" high-volume propeller pump. It also can provide hydraulic power to run many other hydraulic tools now available.



Unit shown with standard roll cage frame
Optional wheel kit is available

FEATURES

- Reliable Honda Gas Engine with Oil-Alert™ Safety Shutdown
- Roll Cage Frame with Single Point Lifting Eye
- Gear-Type Hydraulic Pump
- Spin-On Return Filter W/ Indicator
- Variable Speed Control
- Hydraulic Oil Cooler
- Tank Top Filler/ Strainer
- HTMA Quick - Disconnect Couplings
- System Relief Valve
- Pressure Control Valve
- Liquid Filled Pressure Gauge
- Fluid Level/ Temperature Gauge

OPTIONS

- Wheel Kit
- Electric Start (HT13GE model)
- Other Flow and Pressure Combinations

B0109



motralec

4 rue Lavoisier . ZA Lavoisier . 95223 HERBLAY CEDEX

Tel. : 01.39.97.65.10 / Fax. : 01.39.97.68.48

Demande de prix / e-mail : service-commercial@motralec.com

www.motralec.com

Model HT13G Overall Dimensions

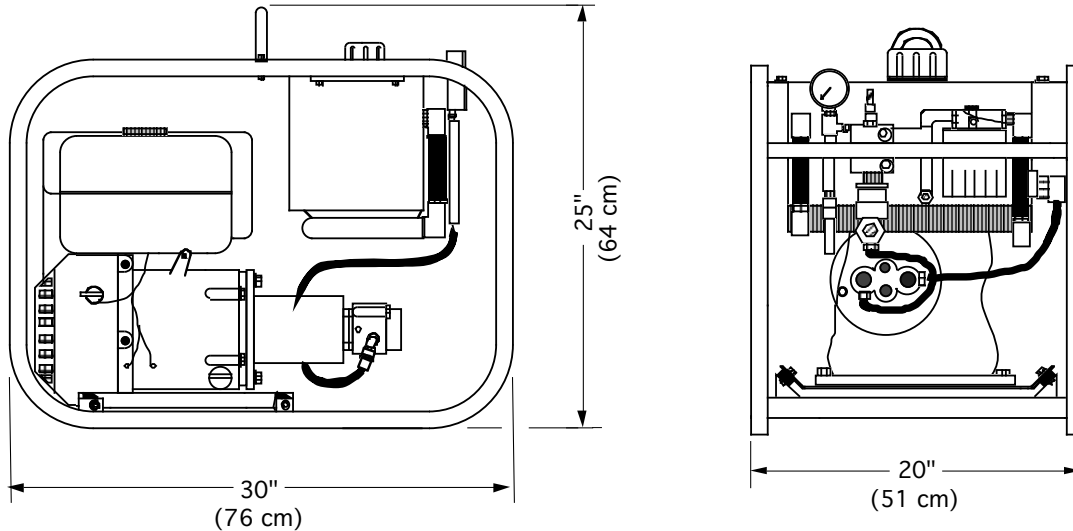

SPECIFICATIONS

ENGINE:..... Honda GX390 Gasoline
HORSE POWER:..... 13 @ 3500 RPM
HYDRAULIC OUTPUT:..... Variable Max 6 GPM (23 LPM)
OPERATING PRESSURE:..... Maximum 2100 PSI (143 Bar)
HOSE PORT SIZE:..... 1/2" NPT
HYDRAULIC OIL:..... SAE 10W or 20W Type AW
also: Dexron ATF or Biodegradable oil
OIL FILTRATION:..... 10 Micron (Standard)
OIL RESERVOIR CAPACITY:..... 4 U.S. Gallons (15.1 Liters)
FUEL TANK CAPACITY:..... 1.8 U.S. Gallons (6.8 Liters)
FUEL CONSUMPTION:..... Approx. .9 U.S. Gal/Hr (3.4 Liters/Hr)
DIMENSIONS:..... H 25" (63.5 cm) x W 20" (51 cm) x L 30" (76 cm)
w/ Wheel Kit H.: 28 3/4" (73 cm) x W 30 1/2" (78 cm) x L 41" (104 cm)

* For Flows and Pressures Other Than Standard, Consult Factory

Since we are constantly working to improve our products, specifications are subject to change without notice.