



water technology

Blue LINE

motralec

4 rue Lavoisier . ZA Lavoisier . 95223 HERBLAY CEDEX
Tel. : 01.39.97.65.10 / Fax. : 01.39.97.68.48
Demande de prix / e-mail : service-commercial@motralec.com
www.motralec.com

Blue Series
BluePRO Series
electrical submersible pumps

BlueBOX
lifting stations

THE ZENIT GROUP



One Group, One Goal

The Zenit Group ranks among the top national and international names in the design and manufacture of water treatment technologies. Its core business is the design and manufacture of submersible electric pumps for domestic and industrial use.

Not just electric pumps

Thanks to the knowledge and experience it has acquired over the years Zenit has also featured on the market with aeration and mixing products, providing a comprehensive range of items designed to meet the most demanding needs.



Character of Success

A solid tradition, dynamism and a penchant for innovation are the salient qualities that have led to Zenit's constant, steady growth, without ever losing sight of its origins and objectives.

Uncompromising Quality

Shrewd corporate decision making has enabled the Zenit Group to carve out for itself considerable portions of the market in which it operates, thus ensuring its customers high technological content and ever-innovative services.



The Customer First and Foremost

Its product differentiation in relation to that of competitors has enabled Zenit to establish with its customers a relationship of growing respect. Zenit is aware of the importance of customer satisfaction and it constantly strives to increase the fidelity of its customers.

We understand the value of finding a willing, efficient and competent business partner and every day at Zenit we work with these objectives in mind to consolidate and increase the faith our customers have placed in us.

Many Members a single Group

Today Zenit is a Group that manages to have direct control over the markets it operates in, thanks to a targeted territorial presence. The Group is composed of four very distinct units that operate by pursuing a single, common, shared goal.

Zenit Italia: production site and sales office for Italy.

Zenit Pumps Suzhou: production site and sales office for China.

Zenit Asia Pacific: sales office for South East Asia.

Zenit Europe: sales office for Europe.



People, Product, Passion

The current structure of the Zenit Group is the result of a successful combination of entrepreneurial strategies and insights that have led to integration between company and globalisation. Bolstered by the conviction that the path we have undertaken is the right one, we can proceed along it together towards a single goal, guided by the 3P formula that has been our constant companion: People - Product - Passion.

PRODUCT IDENTIFICATION

Blue Series

- ① Product name
- ② Serial number
- ③ Number of phases
- ④ Motor power
- ⑤ Power supply voltage frequency
- ⑥ Power supply voltage
- ⑦ Current
- ⑧ Rpm
- ⑨ Minimum and maximum flow-rate
- ⑩ Year of manufacture
- ⑪ Capacitor capacity
- ⑫ Motor insulation class
- ⑬ Casing protection rating
- ⑭ Minimum and maximum head
- ⑮ Maximum immersion depth
- ⑯ Reference standards

Blue PRO Series

- ⑯ Reference standards

TECHNICAL NORMS

Machinery directive 2006/42/CE
 Low voltage directive 2006/95/CE
 Electromagnetic compatibility directive 2004/108/CE

Regulations applied:

UNI EN ISO 12100-1; UNI EN ISO 12100-2; CEI EN 60529; CEI EN 60034-1; CEI EN 60034-2; CEI EN 60335-1; CEI EN 60335-2-41; UNI EN ISO 9906; CEI EN 60204; UNI EN 1561; UNI EN 1563

AVAILABLE VERSIONS

Electric variants

NAE No electric accessories installed
 T Thermistor
 TC Thermistor, capacitor
 TCD Thermistor, capacitor, startup capacitor
 TCDT Thermistor, capacitor, startup capacitor, thermal protector
 TCDGT Thermistor, capacitor, startup capacitor, thermal protector, float switch
 TCG Thermistor, capacitor, float switch
 TCST Thermistor, capacitor, box, thermal protector
 TCSGT Thermistor, capacitor, box, float switch, thermal protector
 TS Thermistor, sensor
 TR Thermistor, relay
 TRG Thermistor, relay, float switch

Set of seals

2SIC Two silicon carbide mechanical seals (SiC)
 SICAL One silicon carbide mechanical seal (SiC) and one carbon-aluminium oxide mechanical seal (AL)

Blue and BluePRO series



The Blue and BluePRO Series are two lines of submersible electric pumps intended mainly for domestic and professional use. These models, designed in association with Pininfarina, are compact in size and offer a large number of innovative technical features.

Blue series models are available with set-back Vortex and channel impellers. They have cast iron structure, technopolymer impeller and handle, two mechanical seals (one in silicon carbide and one in alumina graphite) installed in an oil sump, and a V-ring in direct contact with the liquid. The power ratings available are between 0.3 and 0.74 kW. These products are intended mainly for domestic and residential installations and provide excellent reliability at an economical price.

BluePRO series models have set-back Vortex or open multi-channel cast iron impeller with grinding system, and high head. They have cast iron body, aluminium handle, two silicon carbide mechanical seals installed in an oil sump, and a V-ring in direct contact with the liquid. The power ratings available are between 0.37 and 1.5 kW. They are mainly used in the domestic/civil and professional sectors where high performance or heavy-duty units are needed.

DG Blue - DG BluePRO Set-back Vortex impeller

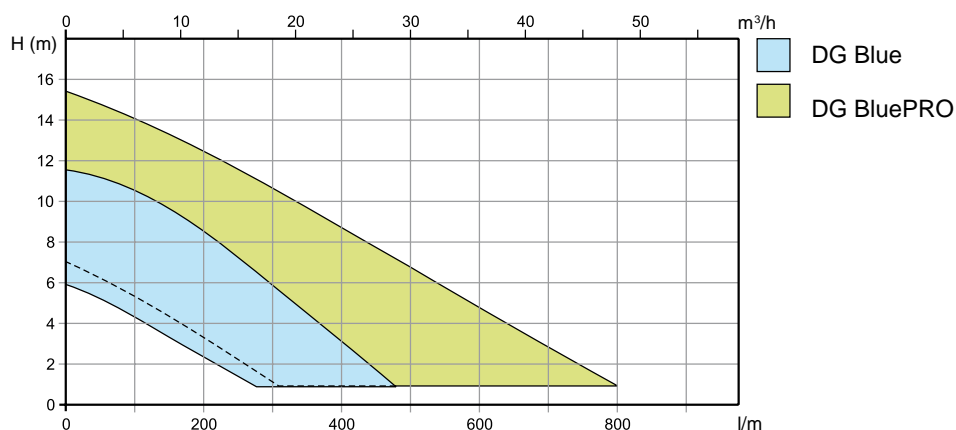

DG Blue Used with soiled biological wastewaters and sewage. Suitable and reliable for domestic use and residential applications.

DG BluePRO Suitable for heavy-duty applications with soiled biological liquids, sewage, rainwater and seepage. This electric pump is intended for both domestic and professional use.

DR Blue - DR BluePRO Multi-channel open impeller

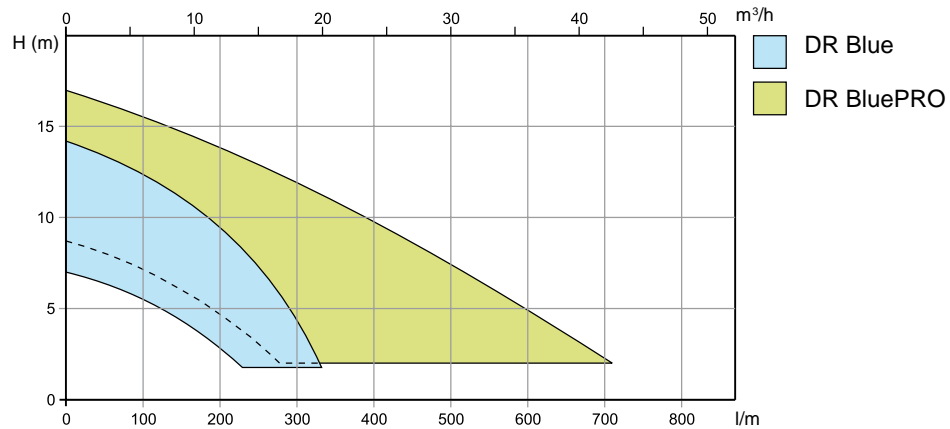

DR Blue

The ideal solution for use with clear or slightly soiled wastewaters containing small solids, strained water, rainwater, seepage and water pumped from underground. Suitable and for specifically domestic use, including heavy-duty applications.

DR BluePRO

Suitable for use with clear or slightly soiled wastewaters containing small solids, strained water, rainwater, seepage and water pumped from underground, where high pumping rates are required. This electric pump is intended for both domestic and professional use.

GR BluePRO Impeller with grinder system

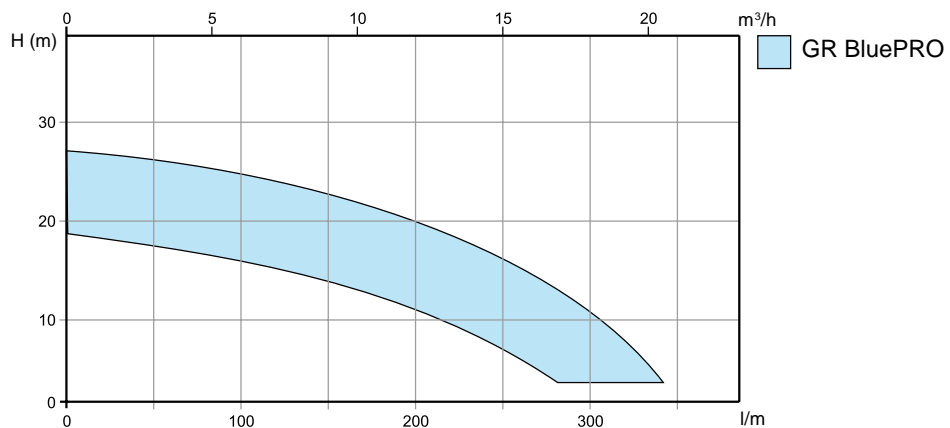

Recommended for unstrained civil wastewaters, including those containing filaments or fibres. This electric pump is intended for both domestic and professional use.

AP BluePRO High head impeller

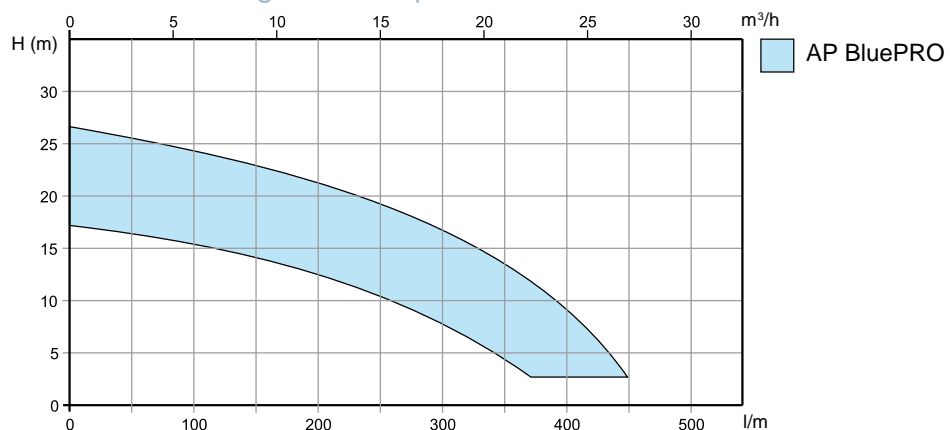

Used for clear wastewater, rainwater and seepage containing small amounts of sand. Its high manometric head makes this series suitable for the creation of water features and decorative fountains. This electric pump is intended for both domestic and professional use.

DG Blue



Set-back Vortex impeller

General characteristics

- † set-back vortex impeller
- † 0,3 ÷ 0,74 kW motor power
- † 2 poles
- † GAS 1 1/2" outlet
- † max 40 mm free passage

Electromechanical assembly

Electromechanical assembly in EN-GJL-250 cast iron, for submerged operation, fitted with 2 (two) opposing mechanical seals in silicon carbide and alumina graphite in oil sump, and V-ring in direct contact with the liquid. Ecological dry motor. Pump body in single casting with motor casing. Series not available in explosion-proof version.

Applications

Used with soiled biological wastewaters and sewage. Suitable and reliable for domestic use and residential applications.

Construction materials

Case	Cast iron EN-GJL 250
Impeller material	Technopolymer
Nuts and bolts	Stainless steel - Class A2-70
Standard gasket	Rubber - NBR
Shaft	Stainless steel - AISI 420
Set of standard mechanical seals	One silicon carbide mechanical seal (SiC) and one carbon-aluminium oxide mechanical seal (AL)

Operating limits

Maximum operating temperature	40 °C
PH of treated fluid	6 to 10 pH
Viscosity of treated fluid	1 mm ² /s
Maximum immersion depth	20 m
Density of treated fluid	1 Kg/dm ³
Maximum acoustic pressure	70 dB
max starts per hour	20

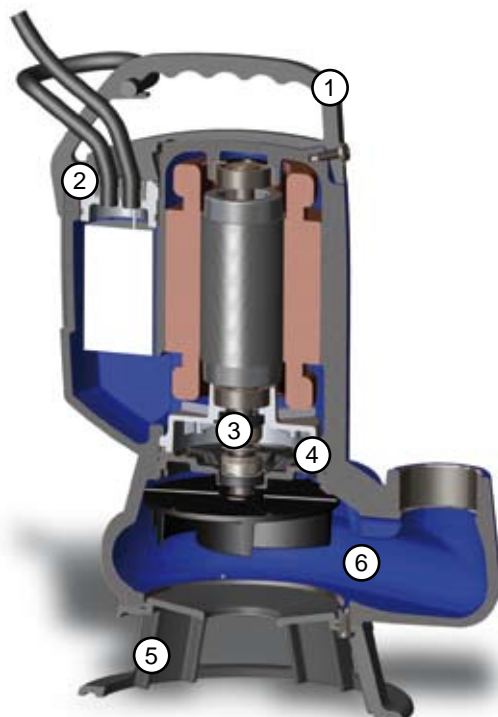

Lifting handle
Convenient technopolymer lifting and carrying handle



Cable Gland System
Innovative cable gland system with twin O-rings to ensure maximum tightness



Mechanical seals
One silicon carbide mechanical seal (SiC) and one carbon-aluminium oxide mechanical seal (AL)

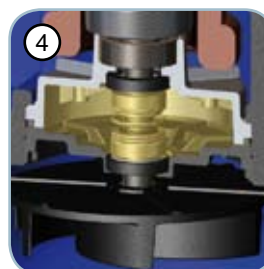

Seal sump
Oil chamber which guarantees longer mechanical seal lifetime, and is easily accessible thanks to a patented system to simplify maintenance procedures



Support foot
Support foot in impact-resistant polypropylene

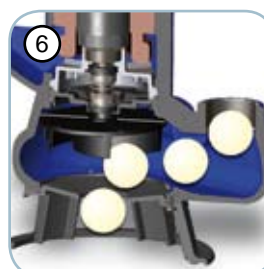

Free passage
Full free passage allowing the expulsion of solids and preventing fouling of the impeller

Models with vertical GAS 1 1/2" threaded delivery port

Performances

	l/s	0	1	2	3	4	5	6	7
	l/min	0	60	120	180	240	300	360	420
	m ³ /h	0	3,6	7,2	10,8	14,4	18,0	21,6	25,2
① DG Blue 40/2/G40V A1BM/50		6,0	5,2	4,0	2,8	1,7			
② DG Blue 50/2/G40V A1BM/50		7,6	6,7	5,5	4,2	2,9	1,6		
③ DG Blue 75/2/G40V A1BM/50		10,1	9,5	8,5	7,2	5,7	4,2	2,6	
④ DG Blue 100/2/G40V A1BM/50		11,6	11,2	10,2	9,1	7,6	6,0	4,3	2,7

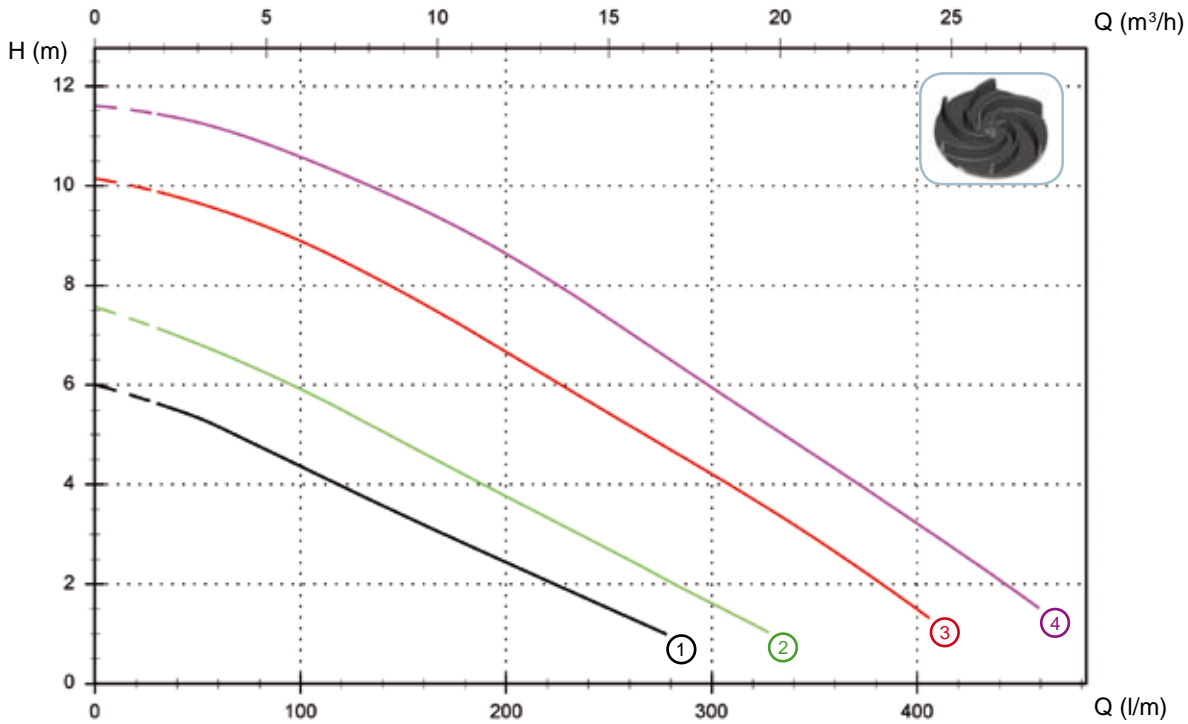

Technical data

	V	Phases	P2(kw)	A	Rpm	Ø	Cable (*)	Free passage
① DG Blue 40/2/G40V A1BM/50	230	1	0.3	2.3	2900	G 1 1/2"	A	40 mm
② DG Blue 50/2/G40V A1BM/50	230	1	0.37	2.8	2900	G 1 1/2"	A	40 mm
③ DG Blue 75/2/G40V A1BM/50	230	1	0.55	4.1	2900	G 1 1/2"	A	40 mm
④ DG Blue 100/2/G40V A1BM/50	230	1	0.74	5.6	2900	G 1 1/2"	A	40 mm

(*) A = H07RN-F 3G1 length 5 metres with schuko plug (05/SH) or 10 metres with schuko plug (10/SH)
 Attention: Standard EN 60335-2-41 requires the use of a 10 meters cable in outdoor applications

Versions available

(Key to versions on page 3)

	Electrical variants											Mechanical seals		
	N	A	E	T	T	C	D	T	T	T	T	T	2SIC	SICAL
DG Blue 40/2/G40V A1BM/50														●
DG Blue 50/2/G40V A1BM/50														●
DG Blue 75/2/G40V A1BM/50														●
DG Blue 100/2/G40V A1BM/50														●

Overall dimensions and weights

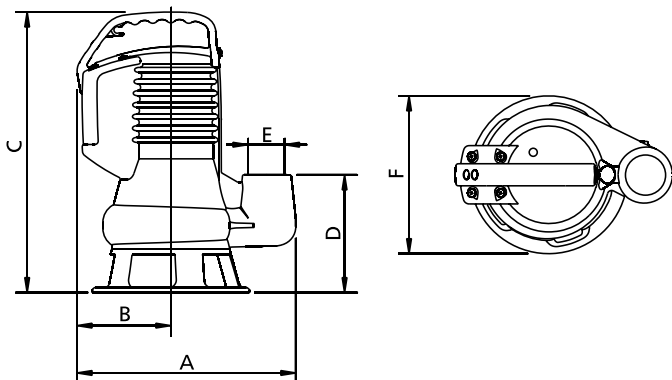

	A	B	C	D	E	F	kg
DG Blue 40/2/G40V A1BM/50	265	115	335	142	G 1 1/2"	190	12.5
DG Blue 50/2/G40V A1BM/50	265	115	335	142	G 1 1/2"	190	13
DG Blue 75/2/G40V A1BM/50	265	115	335	142	G 1 1/2"	190	15
DG Blue 100/2/G40V A1BM/50	265	115	335	142	G 1 1/2"	190	15.5

Measurements in mm

Packaging dimension

	A	B	C
DG Blue 40/2/G40V A1BM/50	240	200	400
DG Blue 50/2/G40V A1BM/50	240	200	400
DG Blue 75/2/G40V A1BM/50	240	200	400
DG Blue 100/2/G40V A1BM/50	240	200	400

Dimension in mm

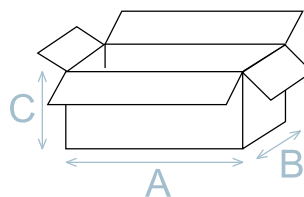

No. pieces per pallet

For DG Blue models each pallet (EUR 1000X1200 mm) is able to take 75 pieces.

Installations available

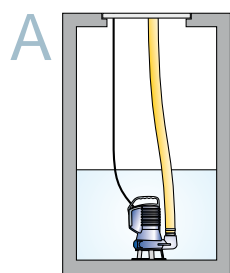

Free installation

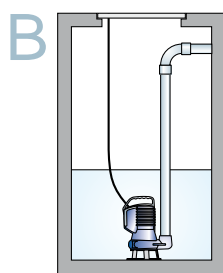

Fixed installation

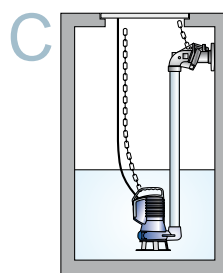

Installation with external coupler

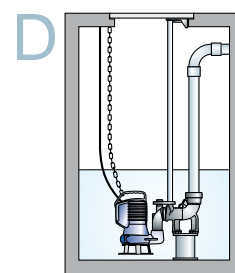

Installation with base coupling foot

DG BluePRO

Set-back Vortex impeller



General characteristics

- † set-back vortex impeller
- † 0,37 ÷ 1,5 kW
- † 2 poles
- † GAS 1 1/2" - 2" outlet
- † max 50 mm free passage

Electromechanical assembly

Electromechanical assembly in EN-GJL-250 cast iron, for submerged operation, fitted with 2 (two) opposing silicon carbide mechanical seals in oil sump, and V-ring in direct contact with the liquid. Ecological dry motor. Pump body in single casting with motor casing. Series not available in explosion-proof version.

Applications

Can be used with slightly soiled biological wastewaters and sewage. Suitable for heavy-duty applications with soiled biological wastewaters, sewage, rainwater and seepage. This electric pump is intended for both domestic and professional use.

Construction materials

Case	Cast iron EN-GJL 250
Impeller material	Cast iron EN-GJL-250
Nuts and bolts	Stainless steel - Class A2-70
Standard gasket	Rubber - NBR
Shaft	Stainless steel - AISI 420
Set of standard mechanical seals	Two silicon carbide mechanical seals (SiC)

Operating limits

Maximum operating temperature	40 °C
PH of treated fluid	6 to 10 pH
Viscosity of treated fluid	1 mm ² /s
Maximum immersion depth	20 m
Density of treated fluid	1 Kg/dm ³
Maximum acoustic pressure	70 dB
max starts per hour	20

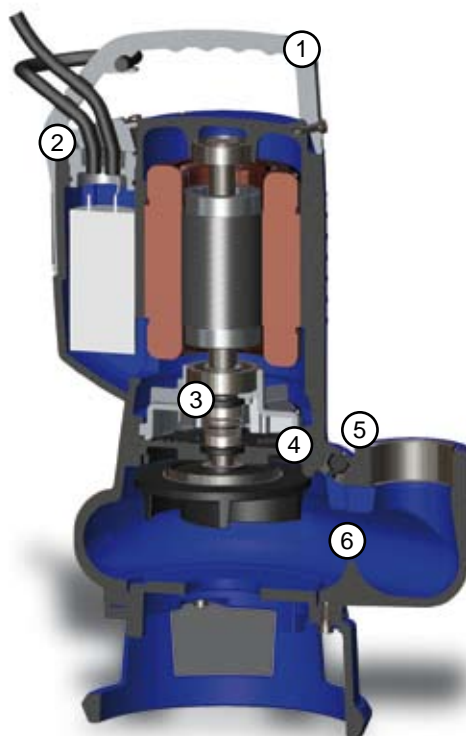

Lifting handle
Aluminium lifting and carrying handle



Cable Gland System
Innovative cable gland system with twin O-rings to ensure maximum tightness



Mechanical seals
Two silicon carbide mechanical seals (SiC)

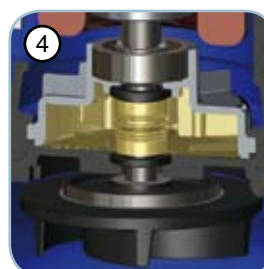

Seal sump
Oil chamber which guarantees longer mechanical seal lifetime, and is easily accessible thanks to a patented system to simplify maintenance procedures

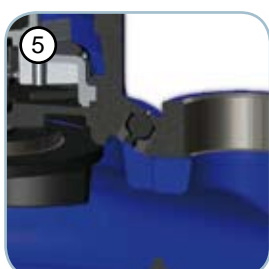

Breather
Breather which allows the air to be vented and ensure reliable pump priming even after long periods out of use

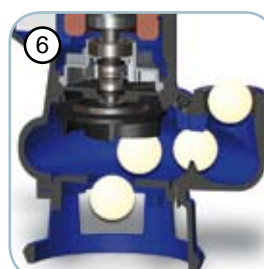

Free passage
Full free passage allowing the expulsion of solids and preventing fouling of the impeller

Models with vertical GAS 1 1/2" threaded delivery port

Performances

	l/s	0	1	2	3	4	5	6	7
	l/min	0	60	120	180	240	300	360	420
	m³/h	0	3,6	7,2	10,8	14,4	18,0	21,6	25,2
① DG BluePRO 50/2/G40V A1BM(T)/50		7,0	6,0	4,9	3,6	2,4	1,1		
② DG BluePRO 75/2/G40V A1BM(T)/50		10,2	9,1	8,0	6,8	5,5	4,1	2,6	
③ DG BluePRO 100/2/G40V A1BM(T)/50		11,4	10,7	9,8	8,7	7,4	5,9	4,4	2,7

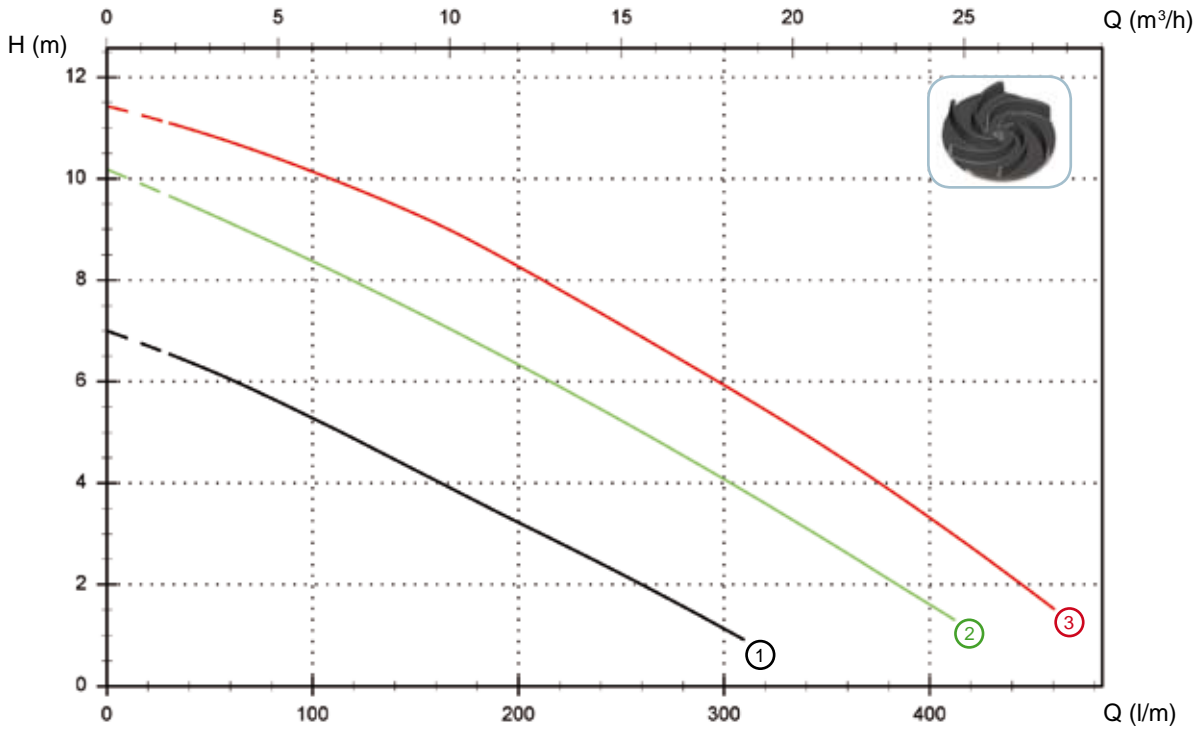

Technical data

	V	Phases	P2(kW)	A	Rpm	Ø	Cable (*)	Free passage
① DG BluePRO 50/2/G40V A1BM/50	230	1	0.37	2.8	2900	G 1 1/2"	A	40 mm
② DG BluePRO 75/2/G40V A1BM/50	230	1	0.55	4.1	2900	G 1 1/2"	A	40 mm
③ DG BluePRO 100/2/G40V A1BM/50	230	1	0.74	5.6	2900	G 1 1/2"	A	40 mm

	V	Phases	P2(kW)	A	Rpm	Ø	Cable (*)	Free passage
① DG BluePRO 50/2/G40V A1BT/50	400	3	0.37	1.15	2900	G 1 1/2"	B	40 mm
② DG BluePRO 75/2/G40V A1BT/50	400	3	0.55	1.6	2900	G 1 1/2"	B	40 mm
③ DG BluePRO 100/2/G40V A1BT/50	400	3	0.74	2.15	2900	G 1 1/2"	B	40 mm

(*) A = H07RN-F 3G1 length 5 metres with schuko plug (05/SH) or 10 metres with schuko plug (10/SH)
 B = H07RN-F 4G1 length 5 metres (05) or 10 metres (10)

Attention: Standard EN 60335-2-41 requires the use of a 10 meters cable in outdoor applications

Models with vertical GAS 2" threaded delivery port

Performances

	l/s	0	2	4	6	8	10	12
	l/min	0	120	240	360	480	600	720
	m ³ /h	0	7,2	14,4	21,6	28,8	36,0	43,2
① DG BluePRO 150/2/G50V A1CM(T)/50		12,3	10,7	8,8	6,5	4,4	2,4	
② DG BluePRO 200/2/G50V A1CM(T)/50		15,3	13,7	11,7	9,4	7,1	4,7	2,5

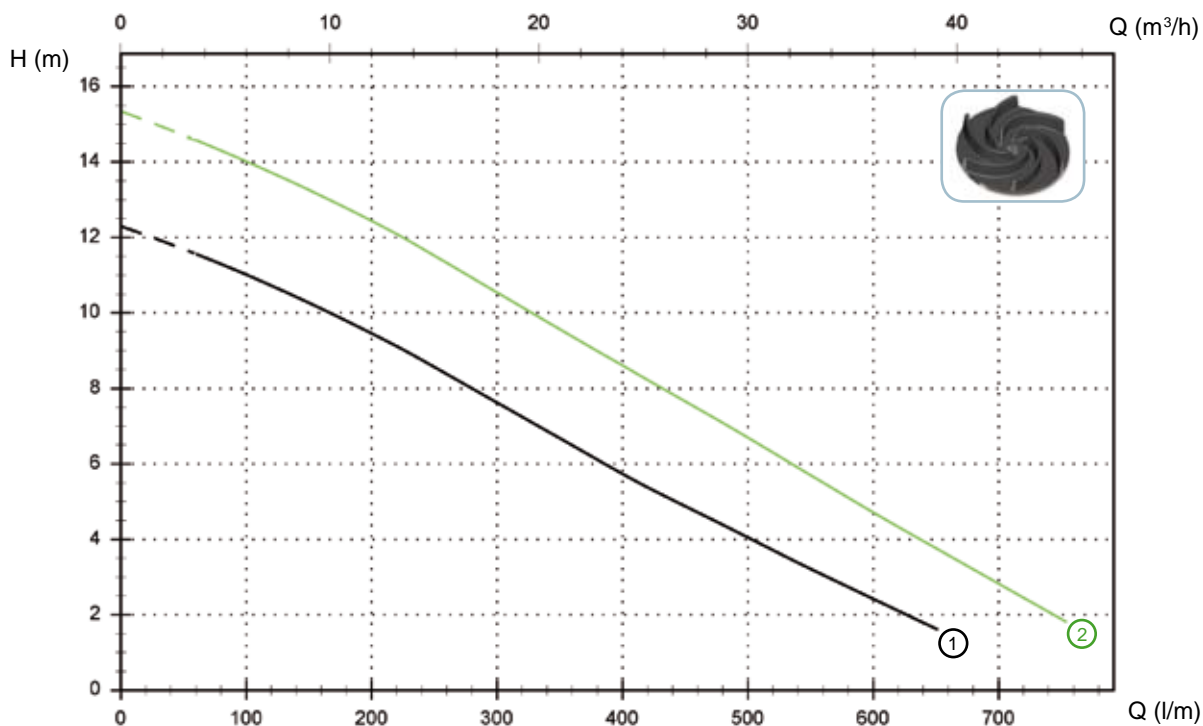

Technical data

	V	Phases	P2(kW)	A	Rpm	Ø	Cable (*)	Free passage
① DG BluePRO 150/2/G50V A1CM/50	230	1	1.1	7.5	2900	G 2"	A	50 mm
② DG BluePRO 200/2/G50V A1CM/50	230	1	1.5	10	2900	G 2"	A	50 mm

	V	Phases	P2(kW)	A	Rpm	Ø	Cable (*)	Free passage
① DG BluePRO 150/2/G50V A1CT/50	400	3	1.1	3.2	2900	G 2"	B	50 mm
② DG BluePRO 200/2/G50V A1CT/50	400	3	1.5	4.3	2900	G 2"	B	50 mm

(*) A = H07RN-F 3G1 length 5 metres with schuko plug (05/SH) or 10 metres with schuko plug (10/SH)
 B = H07RN-F 4G1 length 5 metres (05) or 10 metres (10)

Attention: Standard EN 60335-2-41 requires the use of a 10 meters cable in outdoor applications

Versions available

(Key to versions on page 3)

	Electrical variants										Mechanical seals		
	N A E	T C	T C D	T C D T	T C D G T	T C G	T C S T	T C S G T	T S	T R	T R G	2SIC	SICAL
DG BluePRO 50/2/G40V A1BM/50		●				●						●	
DG BluePRO 75/2/G40V A1BM/50		●				●						●	
DG BluePRO 100/2/G40V A1BM/50		●				●						●	
DG BluePRO 150/2/G50V A1CM/50		●				●						●	
DG BluePRO 200/2/G50V A1CM/50		●				●						●	
DG BluePRO 50/2/G40V A1BT/50	●										●	●	
DG BluePRO 75/2/G40V A1BT/50	●										●	●	
DG BluePRO 100/2/G40V A1BT/50	●										●	●	
DG BluePRO 150/2/G50V A1CT/50	●										●	●	
DG BluePRO 200/2/G50V A1CT/50	●										●	●	

Overall dimensions and weights

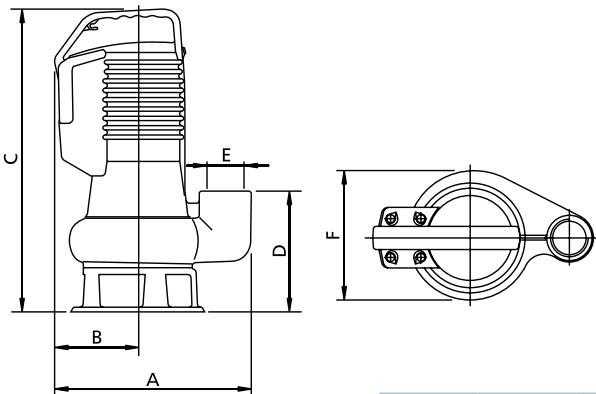

	A	B	C	D	E	F	kg
DG BluePRO 50/2/G40V A1BM(T)/50	265	115	335	140	G 1 1/2"	190	13
DG BluePRO 75/2/G40V A1BM(T)/50	265	115	335	140	G 1 1/2"	190	15
DG BluePRO 100/2/G40V A1BM(T)/50	265	115	335	140	G 1 1/2"	190	15.5

Measurements in mm

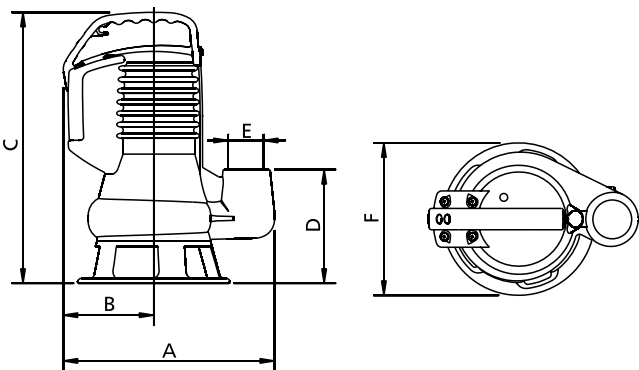

	A	B	C	D	E	F	kg
DG BluePRO 150/2/G50V A1CM(T)/50	295	125	465	195	G 2"	200	23
DG BluePRO 200/2/G50V A1CM(T)/50	295	125	465	195	G 2"	200	24

Measurements in mm

Packaging dimension

	A	B	C
DG BluePRO 50/2/G40V A1BM(T)/50	240	200	400
DG BluePRO 75/2/G40V A1BM(T)/50	240	200	400
DG BluePRO 100/2/G40V A1BM(T)/50	240	200	400
DG BluePRO 150/2/G50V A1CM(T)/50	300	250	480
DG BluePRO 200/2/G50V A1CM(T)/50	300	250	480

Dimension in mm

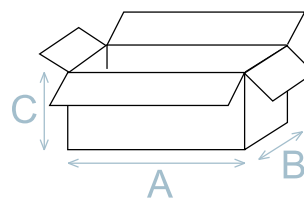

No. pieces per pallet

For DG BluePRO 50-75-100 models each pallet (EUR 1000X1200 mm) is able to take 75 pieces.
 For DG BluePRO 150-200 models each pallet (EUR 1000X1200 mm) is able to take 32 pieces.

Installations available

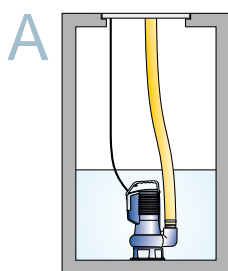

Free installation

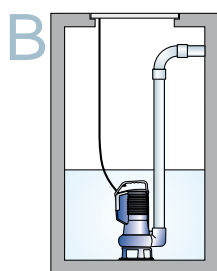

Fixed installation

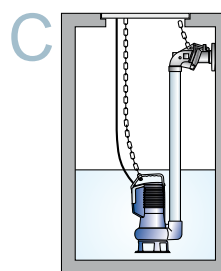

Installation with external coupler

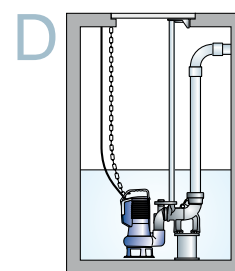

Installation with base coupling foot

DR Blue



Multi-channel open impeller

General characteristics

- † multi-channel open impeller
- † 0,3 ÷ 0,74 kW
- † 2 poles
- † GAS 1 1/4" outlet
- † 7 mm free passage

Electromechanical assembly

Electromechanical assembly in EN-GJL-250 cast iron, for submerged operation, fitted with 2 (two) opposing mechanical seals in silicon carbide and alumina graphite in oil sump, and V-ring in direct contact with the liquid. Ecological dry motor. Pump body in single casting with motor casing. Series not available in explosion-proof version.

Applications

The ideal solution for use with clear or slightly soiled wastewaters containing small solids, strained water, rainwater, seepage and water pumped from underground. Suitable and reliable for domestic use, including heavy-duty applications.

Construction materials

Case	Cast iron EN-GJL 250
Impeller material	Technopolymer
Nuts and bolts	Stainless steel - Class A2-70
Standard gasket	Rubber - NBR
Shaft	Stainless steel - AISI 420
Set of standard mechanical seals	One silicon carbide mechanical seal (SiC) and one carbon-aluminium oxide mechanical seal (AL)

operating limits

Maximum operating temperature	40 °C
PH of treated fluid	6 to 10 pH
Viscosity of treated fluid	1 mm ² /s
Maximum immersion depth	20 m
Density of treated fluid	1 Kg/dm ³
Maximum acoustic pressure	70 dB
max starts per hour	20

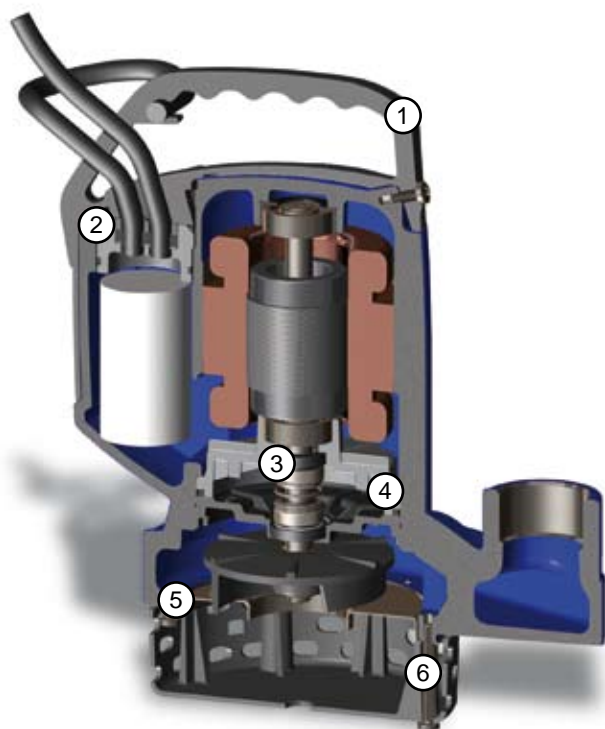

Lifting handle

Convenient technopolymer lifting and carrying handle



Cable Gland System

Innovative cable gland system with twin O-rings to ensure maximum tightness



Mechanical seals

One silicon carbide mechanical seal (SiC) and one carbon-aluminium oxide mechanical seal (AL)

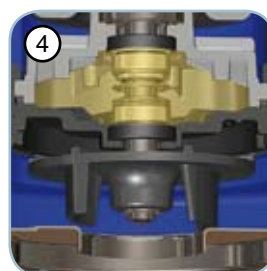

Seal sump

Oil chamber which guarantees longer mechanical seal lifetime, and is easily accessible thanks to a patented system to simplify maintenance procedures



Anti-clogging System

The diffuser plate incorporates the Anti Clogging System (ACS), consisting of grooves in the plate to facilitate the ejection of solids.



Intake strainer

Intake strainer in impact-resistant polypropylene

Models with vertical GAS 1 1/4" threaded delivery port

Performances

	l/s	0	1	2	3	4	5
	l/min	0	60	120	180	240	300
	m ³ /h	0	3,6	7,2	10,8	14,4	18,0
①	DR Blue 40/2/G32V A1BM/50	7,0	6,3	5,1	3,6		
②	DR Blue 50/2/G32V A1BM/50	9,5	8,4	7,0	5,1	2,7	
③	DR Blue 75/2/G32V A1BM/50	12,0	10,8	9,3	7,3	5,0	
④	DR Blue 100/2/G32V A1BM/50	14,2	13,3	11,9	10,3	8,0	4,5

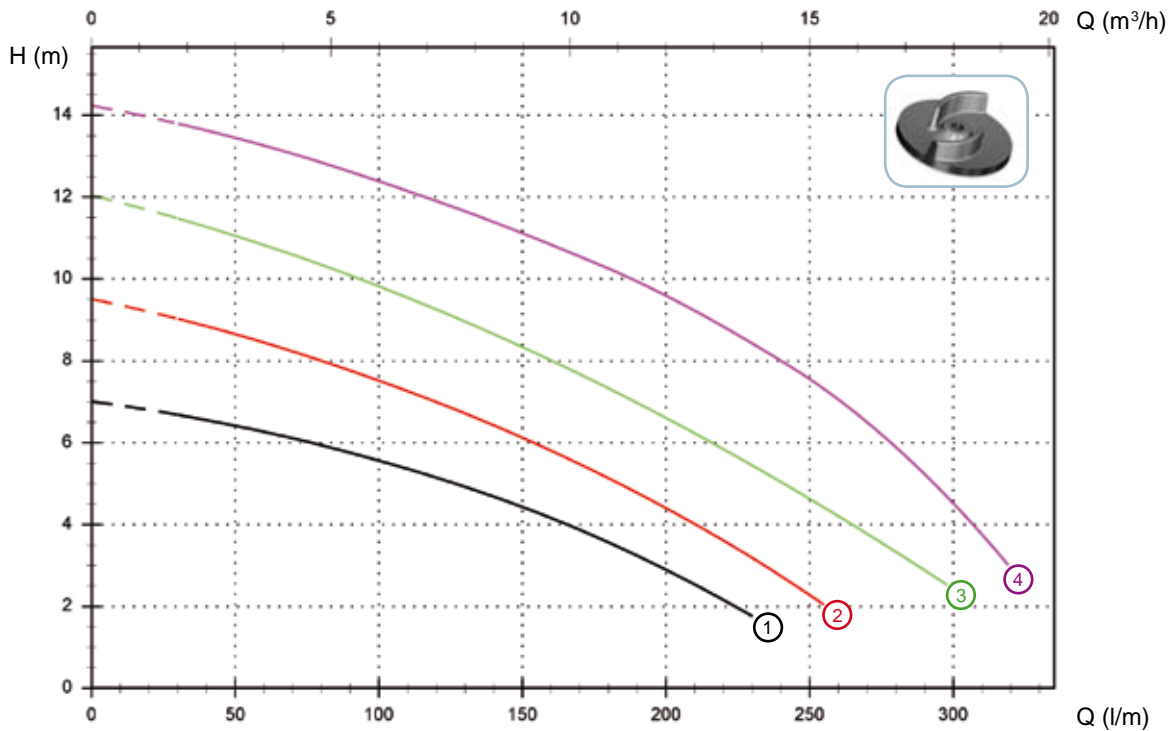

Technical data

	V	Phases	P2(kw)	A	Rpm	Ø	Cable (*)	Free passage	
①	DR Blue 40/2/G32V A1BM/50	230	1	0.3	2.3	2900	G 1 1/4"	A	7 mm
②	DR Blue 75/2/G32V A1BM/50	230	1	0.55	4.1	2900	G 1 1/4"	A	7 mm
③	DR Blue 50/2/G32V A1BM/50	230	1	0.37	2.8	2900	G 1 1/4"	A	7 mm
④	DR Blue 100/2/G32V A1BM/50	230	1	0.74	5.6	2900	G 1 1/4"	A	7 mm

(*) A = H07RN-F 3G1 length 5 metres with schuko plug (05/SH) or 10 metres with schuko plug (10/SH)
 Attention: Standard EN 60335-2-41 requires the use of a 10 meters cable in outdoor applications

Versions available

(Key to versions on page 3)

	Electrical variants										Mechanical seals	
	N A E	T C	T C D	T C D T	T C D G T	T C G	T C S T	T C S G T	T S R	T R G	2SIC	SICAL
DR Blue 40/2/G32V A1BM/50						●						●
DR Blue 50/2/G32V A1BM/50						●						●
DR Blue 75/2/G32V A1BM/50						●						●
DR Blue 100/2/G32V A1BM/50						●						●

Overall dimensions and weights

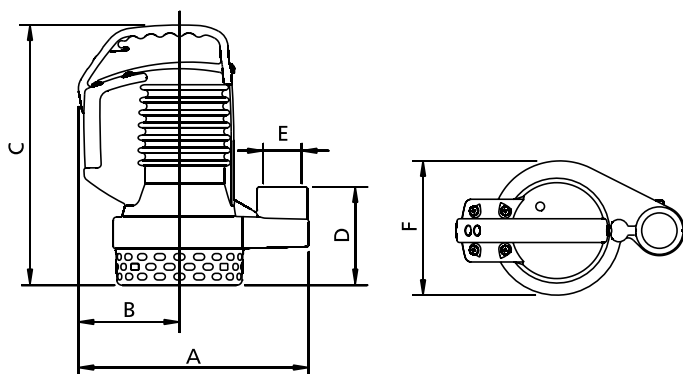

	A	B	C	D	E	F	kg
DR Blue 40/2/G32V A1BM/50	255	115	295	110	G 1 1/4"	150	11.5
DR Blue 50/2/G32V A1BM/50	255	115	295	110	G 1 1/4"	150	12
DR Blue 75/2/G32V A1BM/50	255	115	295	110	G 1 1/4"	150	13.5
DR Blue 100/2/G32V A1BM/50	255	115	295	110	G 1 1/4"	150	15.5

Measurements in mm

Packaging dimension

	A	B	C
DR Blue 40/2/G32V A1BM/50	240	200	350
DR Blue 50/2/G32V A1BM/50	240	200	350
DR Blue 75/2/G32V A1BM/50	240	200	350
DR Blue 100/2/G32V A1BM/50	240	200	350

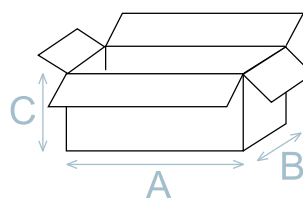

Dimension in mm

No. pieces per pallet

For DR Blue models each pallet (EUR 1000X1200 mm) is able to take 75 pieces.

Installations available

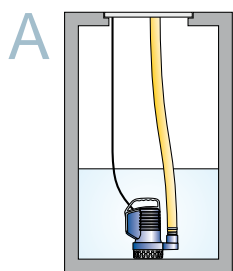

Free installation

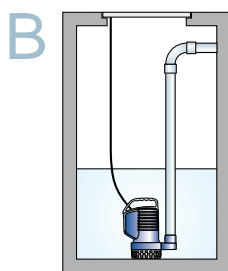

Fixed installation

DR BluePRO

Multi-channel open impeller



General characteristics

- † multi-channel open impeller
- † 0,37 ÷ 1,5 kW
- † 2 poles
- † GAS 1/4" - 2" outlet
- † max 15 mm free passage

Electromechanical assembly

Electromechanical assembly in EN-GJL-250 cast iron, for submerged operation, fitted with 2 (two) opposing silicon carbide mechanical seals in oil sump, and V-ring in direct contact with the liquid. Ecological dry motor. Pump body in single casting with motor casing. Series not available in explosion-proof version.

Applications

Suitable for use with clear or slightly soiled wastewaters containing small solids, strained water, rainwater, seepage and water pumped from underground, where high pumping rates are required. This electric pump is intended for both domestic and professional use.

Construction materials

Case	Cast iron EN-GJL 250
Impeller material	Cast iron EN-GJL-250
Nuts and bolts	Stainless steel - Class A2-70
Standard gasket	Rubber - NBR
Shaft	Stainless steel - AISI 420
Set of standard mechanical seals	Two Silicon carbide mechanical seals (SiC)

Operating limits

Maximum operating temperature	40 °C
PH of treated fluid	6 to 10 pH
Viscosity of treated fluid	1 mm ² /s
Maximum immersion depth	20 m
Density of treated fluid	1 Kg/dm ³
Maximum acoustic pressure	70 dB
max starts per hour	20

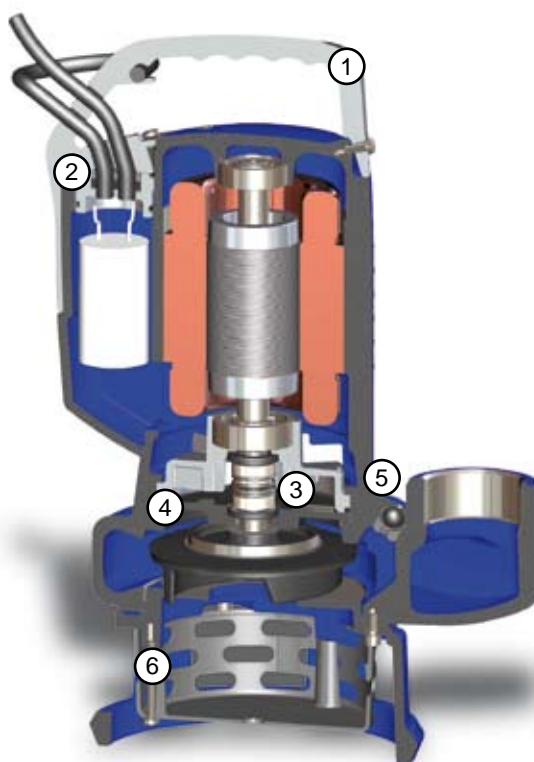

Lifting handle
Aluminium lifting and carrying handle



Cable Gland System
Innovative cable gland system with twin O-rings to ensure maximum tightness



Mechanical seals
Two silicon carbide mechanical seals (SiC)

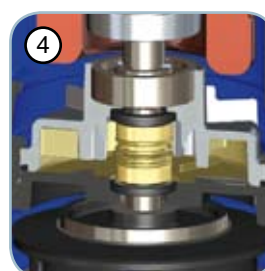

Seal sump
Oil chamber which guarantees longer mechanical seal lifetime, and is easily accessible thanks to a patented system to simplify maintenance procedures

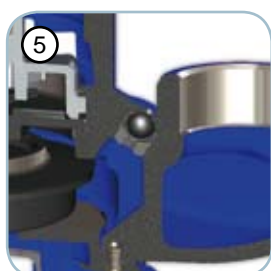

Breather
Breather which allows the air to be vented and ensure reliable pump priming even after long periods out of use



Intake strainer
Intake strainer in stainless steel for 50, 75 and 100 models and in polypropylene with spheroidal cast iron feet for 150 and 200 models

Models with vertical GAS 1 1/4" threaded delivery port

Performances

l/s	0	1	2	3	4	5
l/min	0	60	120	180	240	300
m³/h	0	3,6	7,2	10,8	14,4	18,0

① DR BluePRO 50/2/G32V A1BM(T)/50	8,7	7,9	6,8	5,3	3,4	
② DR BluePRO 75/2/G32V A1BM(T)/50	12,3	11,3	10,0	8,2	5,3	
③ DR BluePRO 100/2/G32V A1BM(T)/50	14,6	13,5	12,1	10,1	7,4	3,1

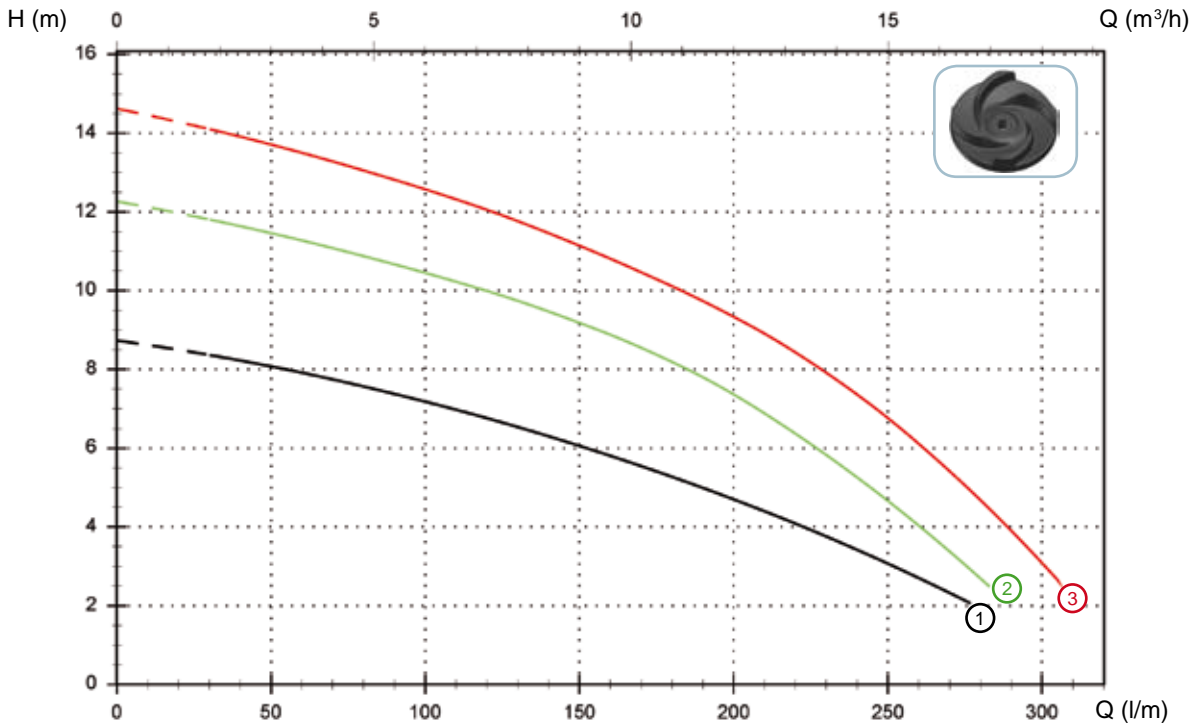

Technical data

	V	Phases	P2(kw)	A	Rpm	Ø	Cable (*)	Free passage
① DR BluePRO 50/2/G32V A1BM/50	230	1	0.37	2.8	2900	G 1 1/4"	A	15 mm
② DR BluePRO 75/2/G32V A1BM/50	230	1	0.55	4.1	2900	G 1 1/4"	A	15 mm
③ DR BluePRO 100/2/G32V A1BM/50	230	1	0.74	5.6	2900	G 1 1/4"	A	15 mm

	V	Phases	P2(kw)	A	Rpm	Ø	Cable (*)	Free passage
① DR BluePRO 50/2/G32V A1BT/50	400	3	0.37	1.15	2900	G 1 1/4"	B	15 mm
② DR BluePRO 75/2/G32V A1BT/50	400	3	0.55	1.6	2900	G 1 1/4"	B	15 mm
③ DR BluePRO 100/2/G32V A1BT/50	400	3	0.74	2.15	2900	G 1 1/4"	B	15 mm

(*) A = H07RN-F 3G1 length 5 metres with schuko plug (05/SH) or 10 metres with schuko plug (10/SH)
 B = H07RN-F 4G1 length 5 metres (05) or 10 metres (10)

Attention: Standard EN 60335-2-41 requires the use of a 10 meters cable in outdoor applications

Models with vertical GAS 2" threaded delivery port

Performances

	l/s	0	2	4	6	8	10
	l/min	0	120	240	360	480	600
	m ³ /h	0	7,2	14,4	21,6	28,8	36,0
① DR BluePRO 150/2/G50V A1CM(T)/50		14,4	12,6	10,9	8,9	6,5	3,1
② DR BluePRO 200/2/G50V A1CM(T)/50		17,0	15,3	13,3	10,9	8,1	5,1

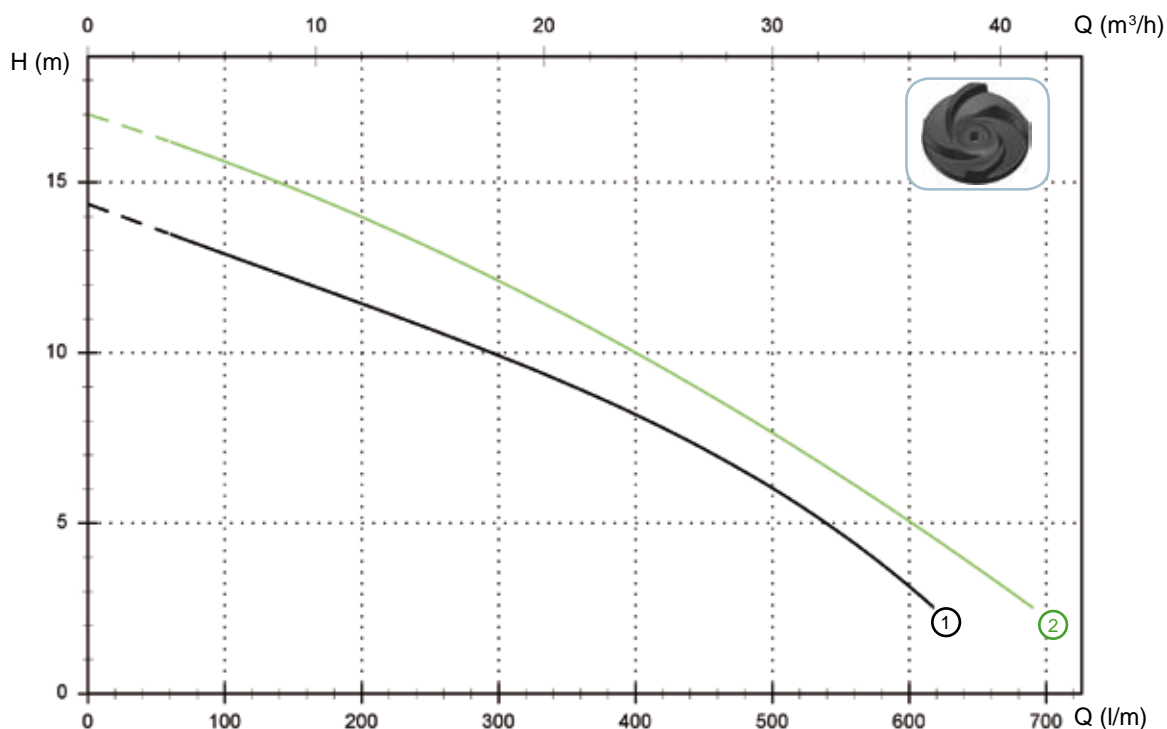

Technical data

	V	Phases	P2(kW)	A	Rpm	Ø	Cable (*)	Free passage
① DR BluePRO 150/2/G50V A1CM/50	230	1	1.1	7.5	2900	G 2"	A	10x30 mm
② DR BluePRO 200/2/G50V A1CM/50	230	1	1.5	10	2900	G 2"	A	10x30 mm

	V	Phases	P2(kW)	A	Rpm	Ø	Cable (*)	Free passage
① DR BluePRO 150/2/G50V A1CT/50	400	3	1.1	3.2	2900	G 2"	B	10x30 mm
② DR BluePRO 200/2/G50V A1CT/50	400	3	1.5	4.3	2900	G 2"	B	10x30 mm

(*) A = H07RN-F 3G1 length 5 metres with schuko plug (05/SH) or 10 metres with schuko plug (10/SH)
 B = H07RN-F 4G1 length 5 metres (05) or 10 metres (10)

Attention: Standard EN 60335-2-41 requires the use of a 10 meters cable in outdoor applications

Versions available

(Key to versions on page 3)

	Electrical variants											Mechanical seals	
	N A E	T C	T C D	T C D T	T C D G T	T C G	T C S T	T C S G T	T S	T R	T R G	2SIC	SICAL
DR BluePRO 50/2/G32V A1BM/50		●				●						●	
DR BluePRO 75/2/G32V A1BM/50		●				●						●	
DR BluePRO 100/2/G32V A1BM/50		●				●						●	
DR BluePRO 150/2/G50V A1CM/50		●				●						●	
DR BluePRO 200/2/G50V A1CM/50		●				●						●	
DR BluePRO 50/2/G32V A1BT/50	●										●	●	
DR BluePRO 75/2/G32V A1BT/50	●										●	●	
DR BluePRO 100/2/G32V A1BT/50	●										●	●	
DR BluePRO 150/2/G50V A1CT/50	●										●	●	
DR BluePRO 200/2/G50V A1CT/50	●										●	●	

Overall dimensions and weights

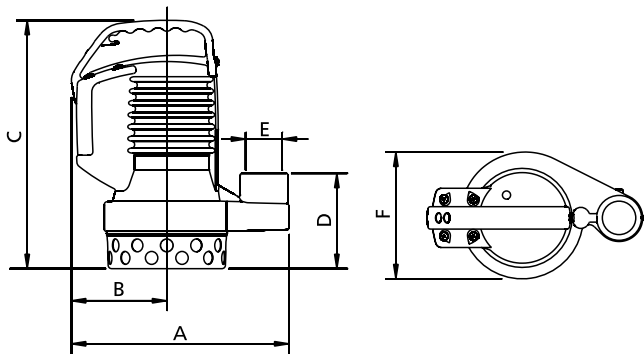

	A	B	C	D	E	F	kg
DR BluePRO 50/2/G32V A1BM(T)/50	255	115	295	110	G 1 1/4"	150	12
DR BluePRO 75/2/G32V A1BM(T)/50	255	115	295	110	G 1 1/4"	150	13.5
DR BluePRO 100/2/G32V A1BM(T)/50	255	115	295	110	G 1 1/4"	150	14

Measurements in mm

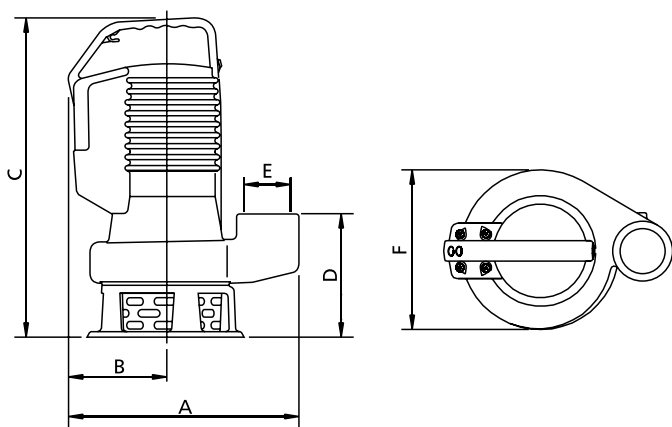

	A	B	C	D	E	F	kg
DR BluePRO 150/2/G50V A1CM(T)/50	295	125	420	170	G 2"	200	23
DR BluePRO 200/2/G50V A1CM(T)/50	295	125	420	170	G 2"	200	24

Measurements in mm

Packaging dimension

	A	B	C
DR BluePRO 50/2/G32V A1BM(T)/50	240	200	350
DR BluePRO 75/2/G32V A1BM(T)/50	240	200	350
DR BluePRO 100/2/G32V A1BM(T)/50	240	200	350
DR BluePRO 150/2/G50V A1CM(T)/50	300	250	480
DR BluePRO 200/2/G50V A1CM(T)/50	300	250	480

Dimension in mm

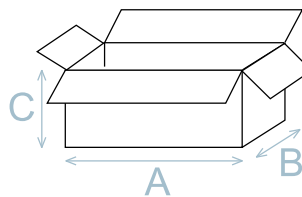

No. pieces per pallet

For DR BluePRO 50-75-100 models each pallet (EUR 1000X1200 mm) is able to take 75 pieces.

For DR BluePRO 150-200 models each pallet (EUR 1000X1200 mm) is able to take 32 pieces.

Installations available

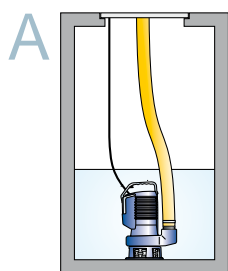

Free installation

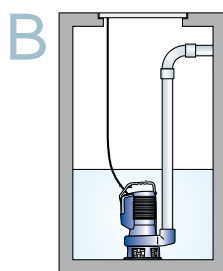

Fixed installation

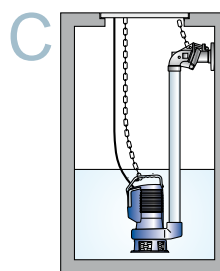

Installation with external coupler

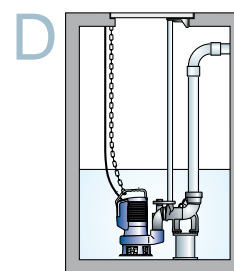

Installation with base coupling foot

GR BluePRO



Impeller with grinder system

General characteristics

- † impeller with grinder system
- † 0,74 ÷ 1,5 kW
- † 2 poles
- † GAS 1 1/2" - DN32 PN6 outlet

Electromechanical assembly

Electromechanical assembly in EN-GJL-250 cast iron, for submerged operation, fitted with 2 (two) opposing silicon carbide mechanical seals in oil sump, and V-ring in direct contact with the liquid. Ecological dry motor. Pump body in single casting with motor casing. Series not available in explosion-proof version.

Applications

Recommended for unstrained civil wastewaters, including those containing filaments or fibres. This electric pump is intended for both domestic and professional use.

Construction materials

Case	Cast iron EN-GJL 250
Impeller material	Cast iron EN-GJL-250
Nuts and bolts	Stainless steel - Class A2-70
Standard gasket	Rubber - NBR
Cutter material	Stainless steel
Cutting disk material	Stainless steel
Shaft	Stainless steel - AISI 420
Set of standard mechanical seals	Two silicon carbide mechanical seals (SiC)

operating limits

Maximum operating temperature	40 °C
PH of treated fluid	6 to 10 pH
Viscosity of treated fluid	1 mm ² /s
Maximum immersion depth	20 m
Density of treated fluid	1 Kg/dm ³
Maximum acoustic pressure	70 dB
max starts per hour	20

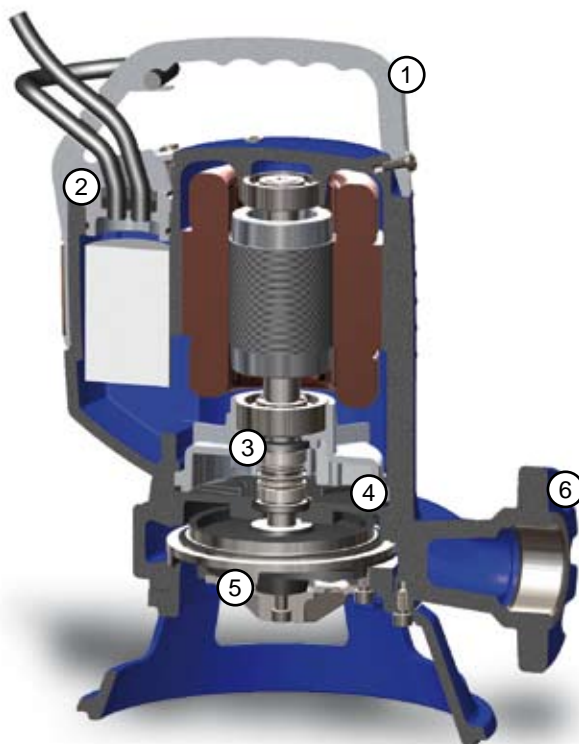

Lifting handle
Aluminium lifting and carrying handle



Cable Gland System
Innovative cable gland system with twin O-rings to ensure maximum tightness



Mechanical seals
Two silicon carbide mechanical seals (SiC)

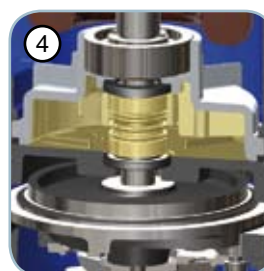

Seal sump
Oil chamber which guarantees longer mechanical seal lifetime, and is easily accessible thanks to a patented system to simplify maintenance procedures



Cutter
Grinder system comprising a revolving cutter and a plate with holes with sharpened edges that fine-chops filaments, preventing fouling of the impeller

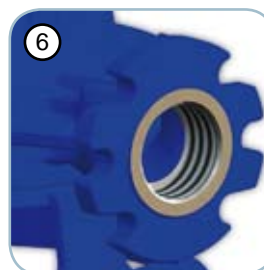

Delivery port
Threaded, flanged delivery port for the maximum ease of installation

Models with horizontal GAS 1 1/2" threaded delivery port and DN32 PN6 ange

Performances

	l/s	0	1	2	3	4	5
	l/min	0	60	120	180	240	300
	m ³ /h	0	3,6	7,2	10,8	14,4	18,0
① GR BluePRO 100/2/G40H A1CM(T)/50		18,0	16,4	14,4	11,5	6,9	
② GR BluePRO 150/2/G40H A1CM(T)/50		21,1	19,6	17,9	15,1	10,4	3,0
③ GR BluePRO 200/2/G40H A1CM(T)/50		27,0	25,6	23,6	20,7	16,1	9,3

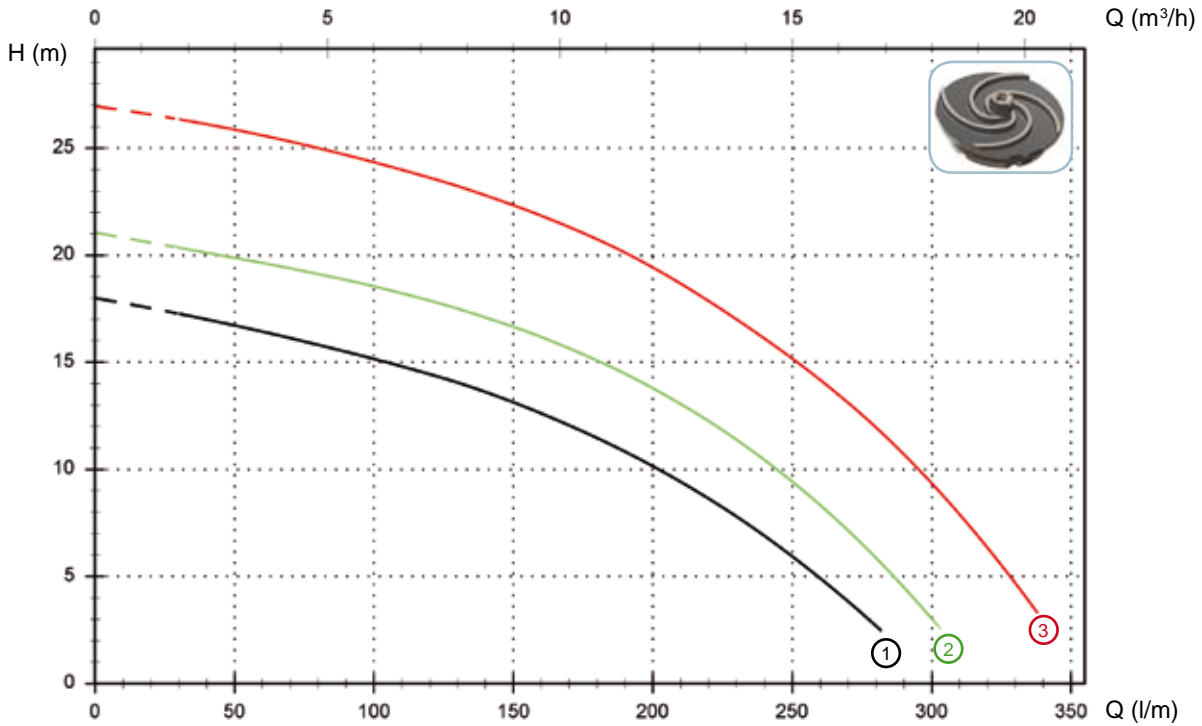

Technical data

	V	Phases	P2(kW)	A	Rpm	Ø	Cable (*)	Free passage
① GR BluePRO 100/2/G40H A1CM/50	230	1	0.74	5.5	2900	G 1 1/2"-DN32 PN6	A	-
② GR BluePRO 150/2/G40H A1CM/50	230	1	1.1	7.5	2900	G 1 1/2"-DN32 PN6	A	-
③ GR BluePRO 200/2/G40H A1CM/50	230	1	1.5	10	2900	G 1 1/2"-DN32 PN6	A	-

	V	Phases	P2(kW)	A	Rpm	Ø	Cable (*)	Free passage
① GR BluePRO 100/2/G40H A1CT/50	400	3	0.74	2.7	2900	G 1 1/2"-DN32 PN6	B	-
② GR BluePRO 150/2/G40H A1CT/50	400	3	1.1	3.2	2900	G 1 1/2"-DN32 PN6	B	-
③ GR BluePRO 200/2/G40H A1CT/50	400	3	1.5	4.3	2900	G 1 1/2"-DN32 PN6	B	-

(*) A = H07RN-F 3G1 length 10 metres
 B = H07RN-F 4G1 length 10 metres

Versions available

(Key to versions on page 3)

	Electrical variants											Mechanical seals	
	N A E	T C	T C D	T C D T	T C D G T	T C G	T C S T	T C S G T	T S	T R	T R G	2SIC	SICAL
GR BluePRO 100/2/G40H A1CM/50				●	●						●		
GR BluePRO 100/2/G40H A1CT/50									●	●	●		
GR BluePRO 150/2/G40H A1CM/50				●	●						●		
GR BluePRO 150/2/G40H A1CT/50									●	●	●		
GR BluePRO 200/2/G40H A1CM/50				●	●						●		
GR BluePRO 200/2/G40H A1CT/50									●	●	●		

Overall dimensions and weights

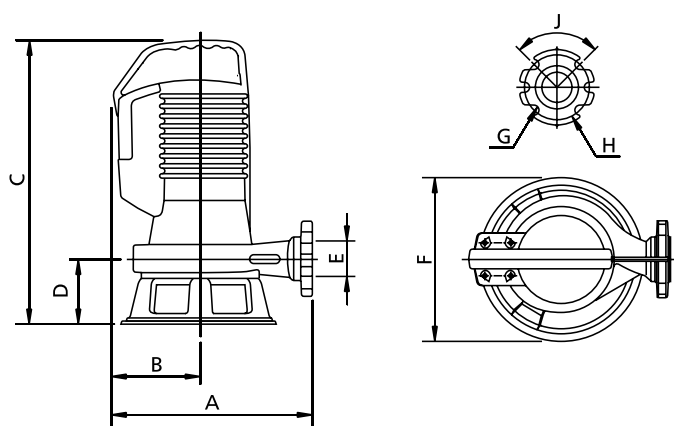

	A	B	C	D	E	F	G	H	J	kg
GR BluePRO 100/2/G40H A1CM(T)/50	270	130	365	95	G 1 1/2"	220	14	90	90°	19
GR BluePRO 150/2/G40H A1CM(T)/50	285	125	410	100	G 1 1/2"	230	14	90	90°	24
GR BluePRO 200/2/G40H A1CM(T)/50	285	125	410	100	G 1 1/2"	230	14	90	90°	25

Measurements in mm

Packaging dimension

	A	B	C
GR BluePRO 100/2/G40H A1CM(T)/50	300	250	400
GR BluePRO 150/2/G40H A1CM(T)/50	300	250	440
GR BluePRO 200/2/G40H A1CM(T)/50	300	250	440

Dimension in mm

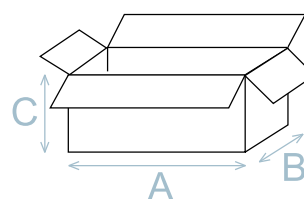

No. pieces per pallet

For GR BluePRO models each pallet (EUR 1000X1200 mm) is able to take 32 pieces.

Installations available

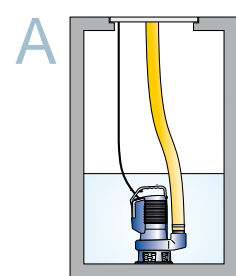

Free installation

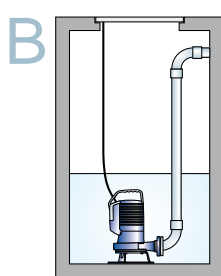

Fixed installation

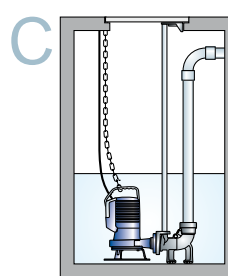

Installation with base coupling foot

AP BluePRO



High head impeller

General characteristics

- † high head impeller
- † 0,74 ÷ 1,5 kW
- † 2 poles
- † GAS 1 1/2" outlet
- † max 6 mm free passage

Electromechanical assembly

Electromechanical assembly in EN-GJL-250 cast iron, for submerged operation, fitted with 2 (two) opposing silicon carbide mechanical seals in oil sump, and V-ring in direct contact with the liquid. Ecological dry motor. Pump body in single casting with motor casing. Series not available in explosion-proof version.

Applications

Used for clear wastewater, rainwater and seepage containing small amounts of sand. Its high manometric head makes this series suitable for the creation of water features and decorative fountains. This electric pump is intended for both domestic and professional use.

Construction materials

Case	Cast iron EN-GJL 250
Impeller material	Cast iron EN-GJL-250
Nuts and bolts	Stainless steel - Class A2-70
Standard gasket	Rubber - NBR
Shaft	Stainless steel - AISI 420
Set of standard mechanical seals	Two silicon carbide mechanical seals (SiC)

operating limits

Maximum operating temperature	40 °C
PH of treated fluid	6 to 10 pH
Viscosity of treated fluid	1 mm ² /s
Maximum immersion depth	20 m
Density of treated fluid	1 Kg/dm ³
Maximum acoustic pressure	70 dB
max starts per hour	20

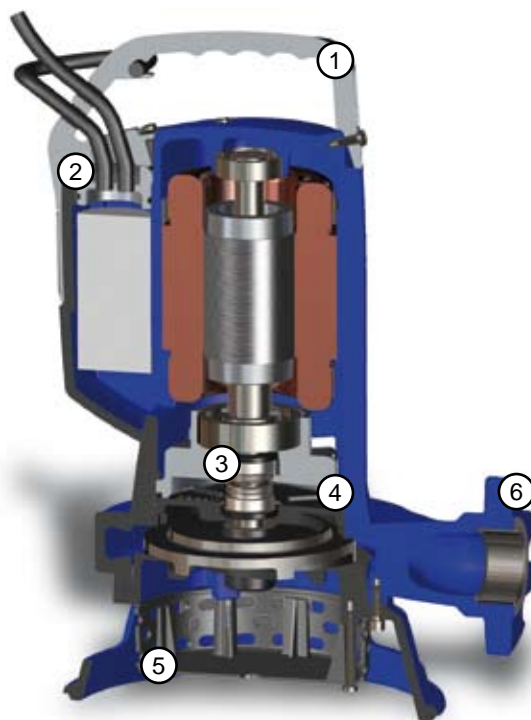

Lifting handle
Aluminium lifting and carrying handle



Cable Gland System
Innovative cable gland system with twin O-rings to ensure maximum tightness



Mechanical seals
Two silicon carbide mechanical seals (SiC)



Seal sump
Oil chamber which guarantees longer mechanical seal lifetime, and is easily accessible thanks to a patented system to simplify maintenance procedures



Intake strainer
Intake strainer in impact-resistant polypropylene and spheroidal cast iron feet

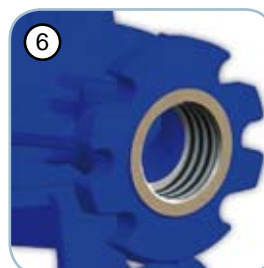

Delivery port
Threaded, flanged delivery port for the maximum ease of installation

Models with horizontal GAS 1 1/2" threaded delivery port and DN32 PN6 angle

Performances

	l/s	0	1	2	3	4	5	6	7
	l/min	0	60	120	180	240	300	360	420
	m ³ /h	0	3,6	7,2	10,8	14,4	18,0	21,6	25,2
① AP BluePRO 100/2/G40H A1CM(T)/50		17,3	16,3	14,9	13,1	10,9	7,8	3,6	
② AP BluePRO 150/2/G40H A1CM(T)/50		20,9	19,8	18,5	16,7	14,6	11,7	7,8	
③ AP BluePRO 200/2/G40H A1CM(T)/50		26,6	25,4	23,8	21,9	19,6	16,7	12,7	6,6

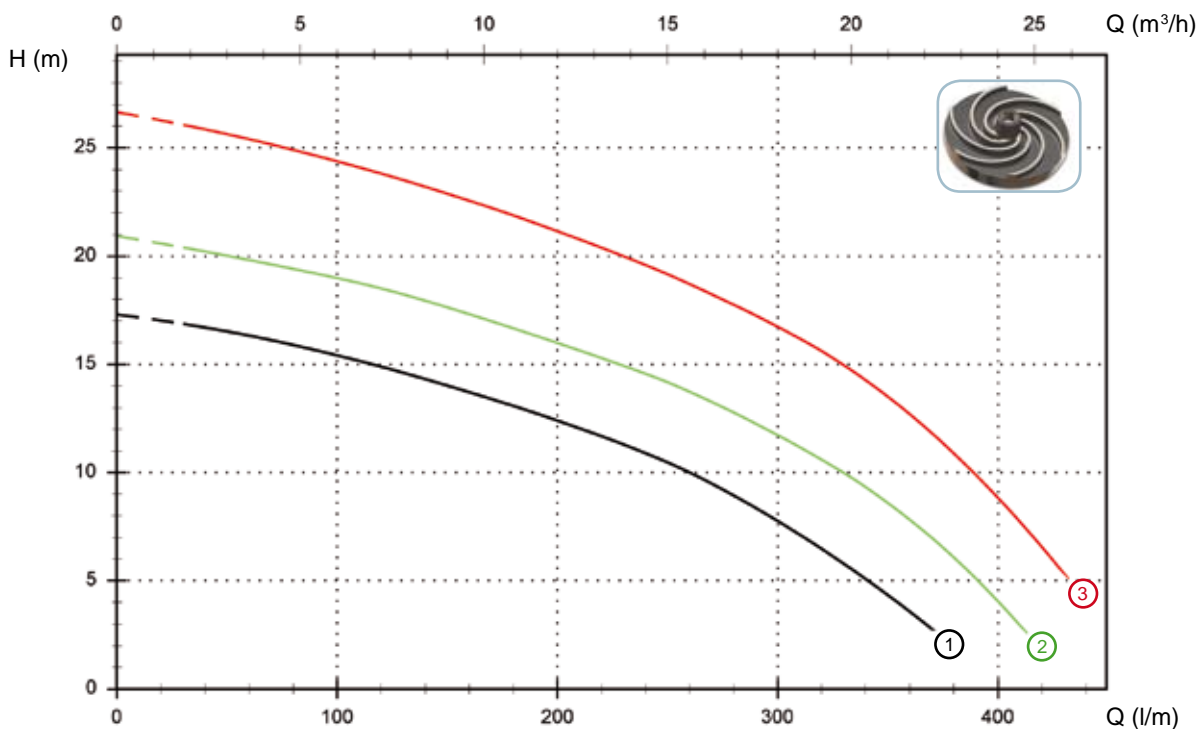

Technical data

	V	Phases	P2(kW)	A	Rpm	Ø	Cable (*)	Free passage
① AP BluePRO 100/2/G40H A1CM/50	230	1	0.74	5.5	2900	G 1 1/2"-DN32 PN6	A	6 mm
② AP BluePRO 150/2/G40H A1CM/50	230	1	1.1	7.5	2900	G 1 1/2"-DN32 PN6	A	6 mm
③ AP BluePRO 200/2/G40H A1CM/50	230	1	1.5	10	2900	G 1 1/2"-DN32 PN6	A	6 mm

	V	Phases	P2(kW)	A	Rpm	Ø	Cable (*)	Free passage
① AP BluePRO 100/2/G40H A1CT/50	400	3	0.74	2.7	2900	G 1 1/2"-DN32 PN6	B	6 mm
② AP BluePRO 150/2/G40H A1CT/50	400	3	1.1	3.2	2900	G 1 1/2"-DN32 PN6	B	6 mm
③ AP BluePRO 200/2/G40H A1CT/50	400	3	1.5	4.3	2900	G 1 1/2"-DN32 PN6	B	6 mm

(*) A = H07RN-F 3G1 length 10 metres
 B = H07RN-F 4G1 length 10 metres

Versions available

(Key to versions on page 3)

	Electrical variants											Mechanical seals	
	N A E	T C	T C D	T C D T	T C D G T	T C G	T C S T	T C S G T	T S	T R	T R G	2SIC	SICAL
AP BluePRO 100/2/G40H A1CM/50		●				●						●	
AP BluePRO 100/2/G40H A1CT/50									●	●		●	
AP BluePRO 150/2/G40H A1CM/50		●				●						●	
AP BluePRO 150/2/G40H A1CT/50									●	●		●	
AP BluePRO 200/2/G40H A1CM/50		●				●						●	
AP BluePRO 200/2/G40H A1CT/50									●	●		●	

Overall dimensions and weights

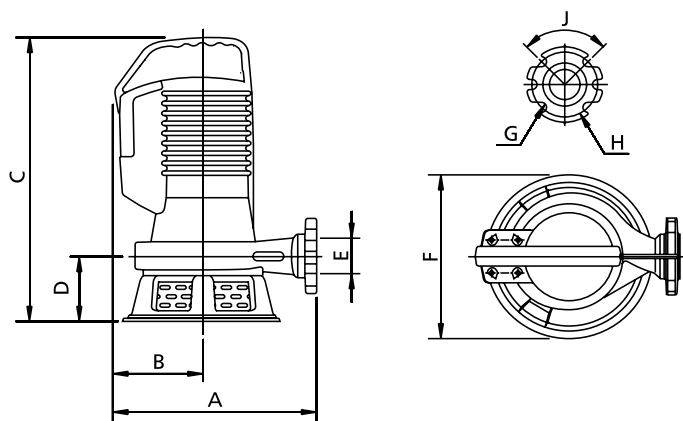

	A	B	C	D	E	F	G	H	J	kg
AP BluePRO 100/2/G40H A1CM(T)/50	270	130	365	95	G 1 1/2"	220	14	90	90°	19
AP BluePRO 150/2/G40H A1CM(T)/50	270	130	365	95	G 1 1/2"	220	14	90	90°	24
AP BluePRO 200/2/G40H A1CM(T)/50	270	130	365	95	G 1 1/2"	220	14	90	90°	19

Measurements in mm

Packaging dimension

	A	B	C
AP BluePRO 100/2/G40H A1CM(T)/50	300	250	400
AP BluePRO 150/2/G40H A1CM(T)/50	300	250	440
AP BluePRO 200/2/G40H A1CM(T)/50	300	250	440

Dimension in mm

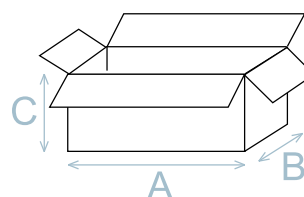

No. pieces per pallet

For AP BluePRO models each pallet (EUR 1000X1200 mm) is able to take 32 pieces.

Installations available

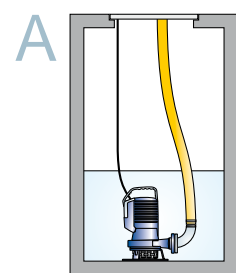

Free installation

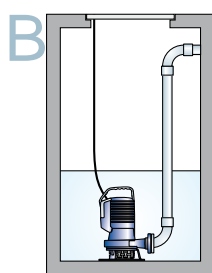

Fixed installation

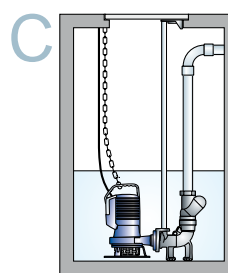

Installation with base coupling foot

LIFTING STATIONS



Prefabricated lifting stations are an effective, economical solution for collecting domestic wastewater and transferring it to a sewer at a higher level or where there are barriers to gravity run-off, or where the wastewater requires grinding. The BlueBOX series consists of rotary moulded polyethylene tanks of 250 or 400 litres, fitted to take one or two pumps respectively. The special shape is inspired by the Pininfarina design of the Blue Series pumps. Their construction characteristics make BlueBOX systems extremely versatile and easy to install.

Operation and Use



The collection tank receives household wastewater from drains of any kind, and any rainwater or seepage drains. The pump installed inside the tank refluxes the wastewater into the sewer. The cover and pipe joints are fitted with seals to ensure airtight connections. BlueBOX units are designed to allow a large number of intake, outlet and ventilation pipe connection options, allowing effective use whatever the space available. A grinder pump capable of breaking down any solids in the wastewater, and refluxing it to large distances, can be installed inside the unit. This allows the pumped liquid to be passed through even small-diameter pipelines, with considerable financial savings on the total cost of the system.

BlueBOX 250 - 400

Technical characteristics

- † 250 litre version for one pump and 400 litre version for two pumps
- † can be installed with coupling device or directly coupled
- † walk-over cover
- † O-ring seal between tank and cover
- † simplified intake or air venting pipe connections with seal
- † airtight cable gland seals
- † integral lifting handles
- † fitted for emergency emptying using a tap
- † PATENTED cable gland allowing easy pump removal for any maintenance work
- † the side fins, in the middle of the tank, guarantee an excellent grip if the unit is installed in-floor (refer to relevant manual)

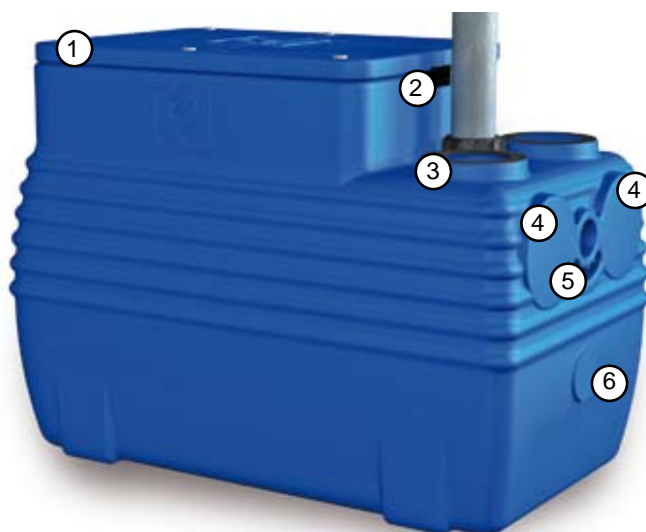

1 Sturdy walk-over cover
The large top opening allows a backup pump to be used for emergency emptying, ensuring operations are simple and hygienic.



2 PATENTED modular cable gland system allowing the pump to be removed with no need to disconnect or extract the power supply cable (refer to relevant manual).



3 Guaranteed airtight thanks to "C" shaped double-lip NBR rubber seals. The seal allows the BlueBOX to be connected to the various pipelines quickly, solving the vibration problem.



4 Wastewater pipeline inlet ports also provided on sides.

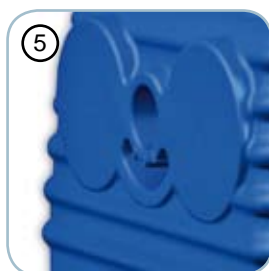

5 Two integral handles for lifting and transport, for easy transfer even by hand.



6 Emergency drainage fitting located low down in the unit.

Installations

BlueBOX 250-400 lt. lifting stations are fitted for installation of Zenit pumps (not included). The delivery pipeline may be in galvanised steel or PVC and is secured to the tank by means of a ring-nut with a seal that ensures airtight sealing. The accessories available allow a variety of installation options depending on the specific requirements.

Permanent installation

Ideal installation for pump with vertical delivery outlet up to 2 1/2". The pump rests on the bottom of the tank. The specially shaped bottom keeps the pump in the correct position. A ball check valve and/or a gate valve can be connected to the end of the delivery pipeline. Permanent installation is definitely the simplest and most economical.

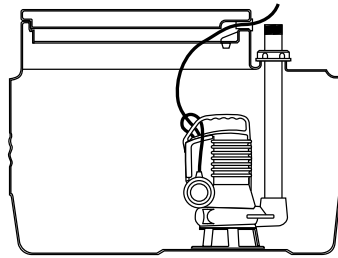

Installation with bottom coupling device (DAC)

Installation with the bottom coupling device allows the pump to be raised and repositioned easily, with no need to empty the tank. Vertical delivery pumps can be installed using a special kit for horizontal DAC units. This is a versatile installation option which simplifies pump maintenance or replacement.

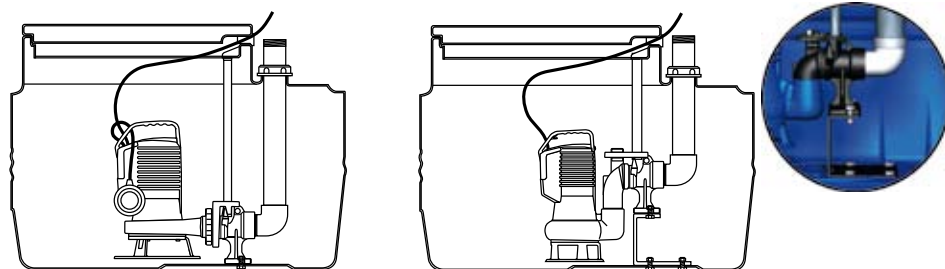

Installation with bottom coupling device (DAC) and ball valve (VAP)

This special, compact accessory provides all the benefits of an ordinary DAC, and also, thanks to an integral venting valve, it prevents air pockets from forming inside the pump body if the unit runs dry. Thanks to this feature, a special ball check valve can be directly connected to the outlet of the DAC inside the BlueBOX, ensuring compact size and removing installation constraints.

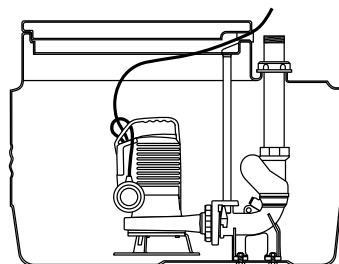

Electrical accessories

With integral float switch

In the event of use of pumps with float switch, BlueBOX lifting stations can be used with no further electric accessories. The float switch starts and stops the pump depending on the level reached.

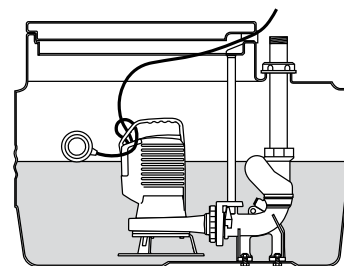

Without integral float switch

In the event of use of pumps without float switch, the BlueBOX lifting station must be equipped with minimum and maximum level float switches, and alarm float switch if required.

The electrical panel complete with all features required for operation of one or two pumps (400 lt) and accessories such as alternating control device or alarm with buzzer and light is available on request.

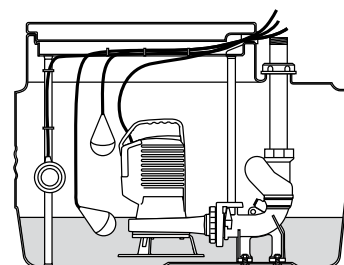

Overall dimensions and weights

BlueBOX 250

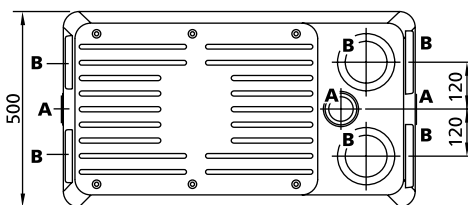
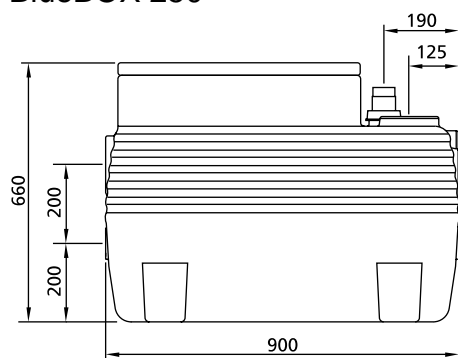

A Ø max 2 1/2"
B Ø max 110 mm
Weight 15 kg

(data without pump and accessories)

BlueBOX 400

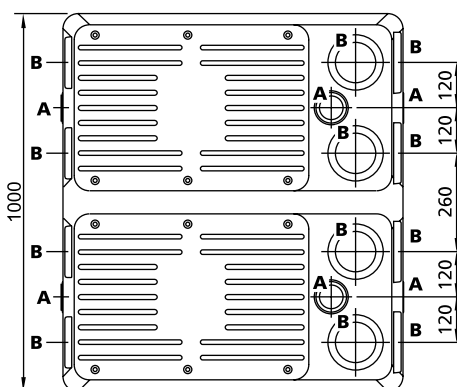
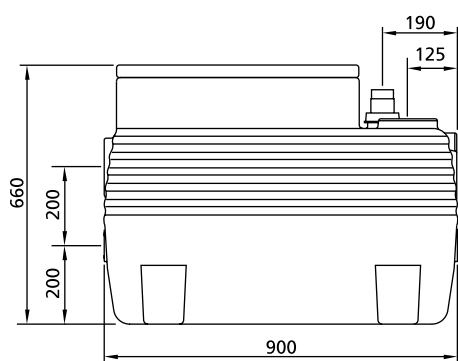

A Ø max 2 1/2"
B Ø max 110 mm
Weight 31 kg

(data without pump and accessories)

Inlets available

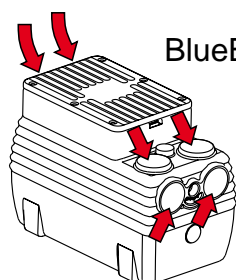

BlueBOX 250

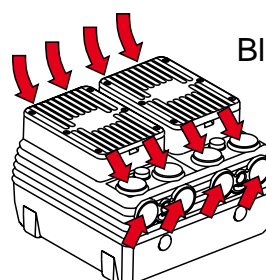

BlueBOX 400

Recommended electric pumps

With vortex impeller

	V	Phases	P2(kW)	A	Rpm	Ø	Free passage
DG Blue 40/2/G40V A1BM/50	230	1	0.3	2.3	2900	G 1 1/2"	40 mm
DG Blue 50/2/G40V A1BM/50	230	1	0.37	2.8	2900	G 1 1/2"	40 mm
DG Blue 75/2/G40V A1BM/50	230	1	0.55	4.1	2900	G 1 1/2"	40 mm
DG Blue 100/2/G40V A1BM/50	230	1	0.74	5.6	2900	G 1 1/2"	40 mm
DG BluePRO 50/2/G40V A1BM/50	230	1	0.37	2.8	2900	G 1 1/2"	40 mm
DG BluePRO 75/2/G40V A1BM/50	230	1	0.55	4.1	2900	G 1 1/2"	40 mm
DG BluePRO 100/2/G40V A1BM/50	230	1	0.74	5.6	2900	G 1 1/2"	40 mm
DG BluePRO 50/2/G40V A1BT/50	400	3	0.37	1.15	2900	G 1 1/2"	40 mm
DG BluePRO 75/2/G40V A1BT/50	400	3	0.55	1.6	2900	G 1 1/2"	40 mm
DG BluePRO 100/2/G40V A1BT/50	400	3	0.74	2.15	2900	G 1 1/2"	40 mm

	l/s	0	2	4	6	8	10	12
	l/min	0	120	240	360	480	600	720
	m ³ /h	0	7,2	14,4	21,6	28,8	36,0	43,2
DG Blue 40/2/G40V A1BM/50		6,0	4,0	1,7				
DG Blue 50/2/G40V A1BM/50		7,6	5,5	2,9				
DG Blue 75/2/G40V A1BM/50		10,1	8,5	5,7	2,6			
DG Blue 100/2/G40V A1BM/50		11,6	10,2	7,6	4,3			
DG BluePRO 50/2/G40V A1BM(T)/50		7,0	4,9	2,4				
DG BluePRO 75/2/G40V A1BM(T)/50		10,2	8,0	5,5	2,6			
DG BluePRO 100/2/G40V A1BM(T)/50		11,4	9,8	7,4	4,4			
DG BluePRO 150/2/G50V A1CM(T)/50		12,3	10,7	8,8	6,5	4,4	2,4	
DG BluePRO 200/2/G50V A1CM(T)/50		15,3	13,7	11,7	9,4	7,1	4,7	2,5



Grinders

	V	Phases	P2(kW)	A	Rpm	Ø	Free passage
GR BluePRO 100/2/G40H A1CM/50	230	1	0.74	5.5	2900	G 1 1/2"- DN32 PN6	-
GR BluePRO 150/2/G40H A1CM/50	230	1	1.1	7.5	2900	G 1 1/2"- DN32 PN6	-
GR BluePRO 200/2/G40H A1CM/50	230	1	1.5	10	2900	G 1 1/2"- DN32 PN6	-
GR BluePRO 100/2/G40H A1CT/50	400	3	0.74	2.7	2900	G 1 1/2"- DN32 PN6	-
GR BluePRO 150/2/G40H A1CT/50	400	3	1.1	3.2	2900	G 1 1/2"- DN32 PN6	-
GR BluePRO 200/2/G40H A1CT/50	400	3	1.5	4.3	2900	G 1 1/2"- DN32 PN6	-

	l/s	0	1	2	3	4	5
	l/min	0	60	120	180	240	300
	m ³ /h	0	3,6	7,2	10,8	14,4	18,0
GR BluePRO 100/2/G40H A1CM(T)/50		18,0	16,4	14,4	11,5	6,9	
GR BluePRO 150/2/G40H A1CM(T)/50		21,1	19,6	17,9	15,1	10,4	3,0
GR BluePRO 200/2/G40H A1CM(T)/50		27,0	25,6	23,6	20,7	16,1	9,3



Outdoor installation

Installing a BlueBOX lifting station could not be easier.

It is supplied partially assembled to speed up installation by the customer.

A large number of construction features simplify installation, and the accessories supplied allow the system to be optimised in all conditions.



The BlueBOX tank can be installed on-floor or in-floor.

Inlet and output pipeline fittings are provided on three sides, allowing installation to be optimised to requirements.



Before the unit is actually placed in position, holes are drilled in the sides using a flared grinding tool to take the seals and then the pipes in the chosen positions.



To ensure perfect sealing, the double lip seal provided is fitted. No additional sealants are required, making installation an extremely quick procedure.



Once our BlueBOX has been placed in the installation position, the wastewater inlet and ventilation pipes are fitted.



The next step is to install the pump, which will certainly be easier if a BlueBOX with DAC was chosen. In this case, the flange provided has only to be slid along the guide tubes to achieve perfect coupling to the body of the DAC.
The BlueBOX contains an accessory that can be fitted to allow emptying in emergencies through the drainage hole low down in the unit.



The electrical cables are passed through special patented rubber cable glands that ensure a perfectly airtight seal. Before fitting the cable, perforate the chosen cable glands with a sharp tool, but leave the others intact to keep liquids or smells inside the unit.



Once installation is complete and operation of the pump and its float switches has been checked, the cover can be screwed into place.
The cover is walk-over but will not support vehicles.



The BlueBOX lifting station is ready for use.
The vast range of plumbing and electrical accessories covers all installation requirements.

motralec

4 rue Lavoisier . ZA Lavoisier . 95223 HERBLAY CEDEX

Tel. : 01.39.97.65.10 / Fax. : 01.39.97.68.48

Demande de prix / e-mail : service-commercial@motralec.com

www.motralec.com