

WEMCO PUMP

Heavy Duty Chopper Pumps

Model CF™ Chop-Flow™ Pump
Chopping While Pumping

Excellent
Power & Industrial
Solutions

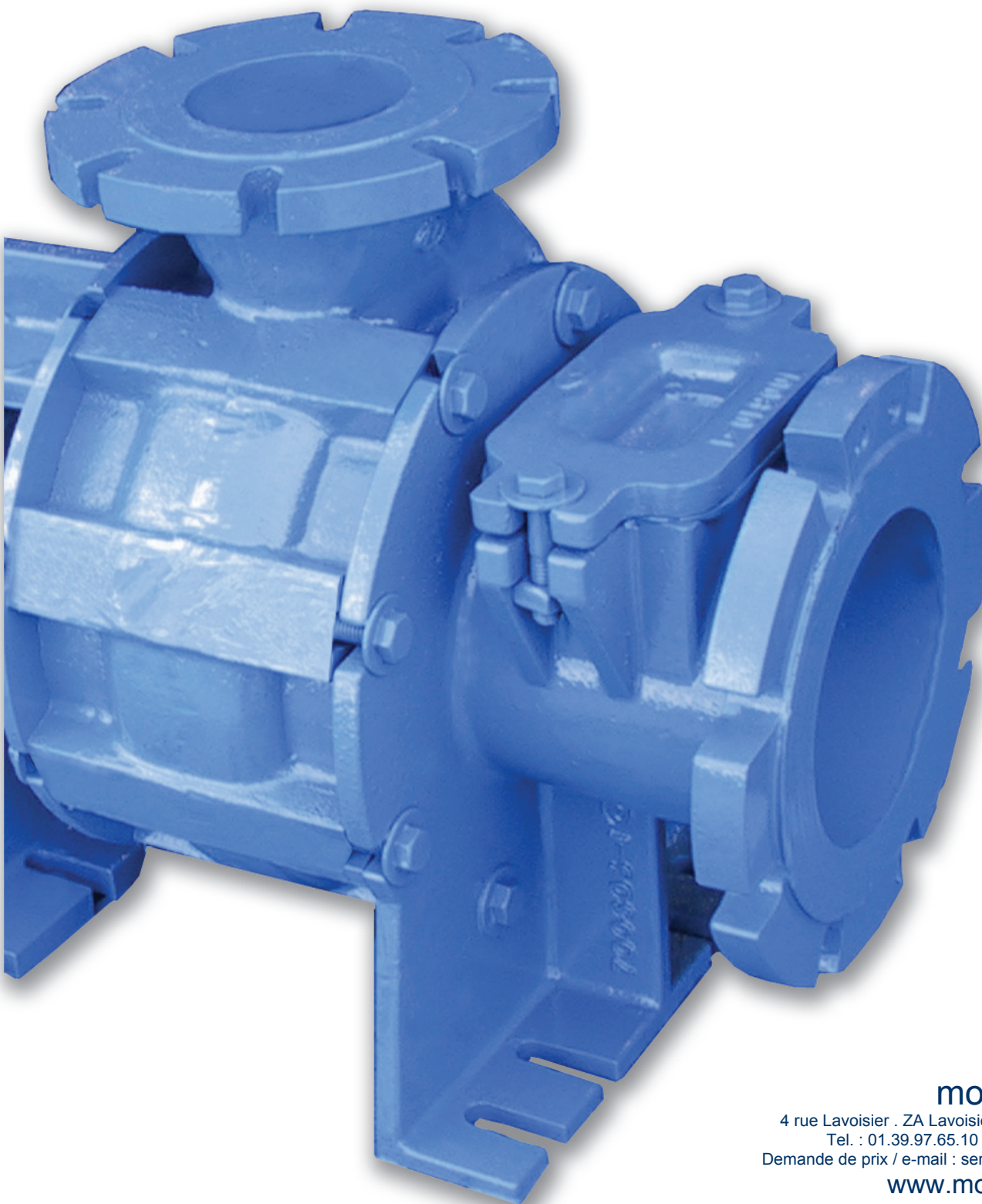

motralec

4 rue Lavoisier . ZA Lavoisier . 95223 HERBLAY CEDEX
Tel. : 01.39.97.65.10 / Fax. : 01.39.97.68.48

Demande de prix / e-mail : service-commercial@motralec.com

www.motralec.com

A New Generation of WEMCO® Pumps

The WEMCO® Model CF™ Chop-Flow™ Pump is a powerful, cost-efficient way to chop and pump at the same time.

Created by the same engineers and manufactured side-by-side with the dependable WEMCO® and WEMCO®-Hidrostal® pumps you already have in service, the WEMCO® Model CF™ chopper pump is just as rugged and dependable. It is a cost-effective addition to the problem-solving, trouble-free WEMCO® pumps you installed years ago.

The Wemco® Model CF™ chopper pump chops as it pumps, keeping oversized solids and stringy material from clogging your downstream process.

Configurations and Sizes available

Available in horizontal, vertical and submersible models with pump sizes 6x3 to 14x12. There is a WEMCO Chop-flow pump with the right size and configuration for your service.

How the Wemco® Chop-Flow™ Chopper Pump Works

Solids, fibrous and other hard to pump materials are pulled into the pump suction. Before these materials enter the pump impeller vanes, they are cut by the action of the rotating impeller against the stationary cutter plate, so they easily pass through the pump after being chopped several hundred times per minute.

Rugged & Dependable Wemco® Chop-Flow® Chopper Pump

The Chop-Flow pump's ability to handle large solids and stringy materials make it ideal for use in waste treatment applications and industrial applications such as pulp & paper, food processing, and meat & poultry production.

When this chopping action is combined with its abrasion & corrosion-resistant materials of construction and rugged, heavy-duty casting, the Chop-Flow will be the workhorse you've come to expect in a WEMCO pump. With a common footprint to other chopper pumps, the Chop-Flow will bolt up to your existing piping and coupling.

Nothing could be easier – PUT IT TO WORK!

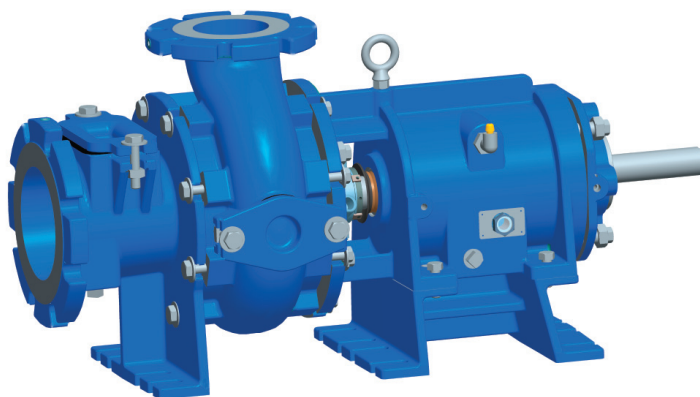

Horizontal

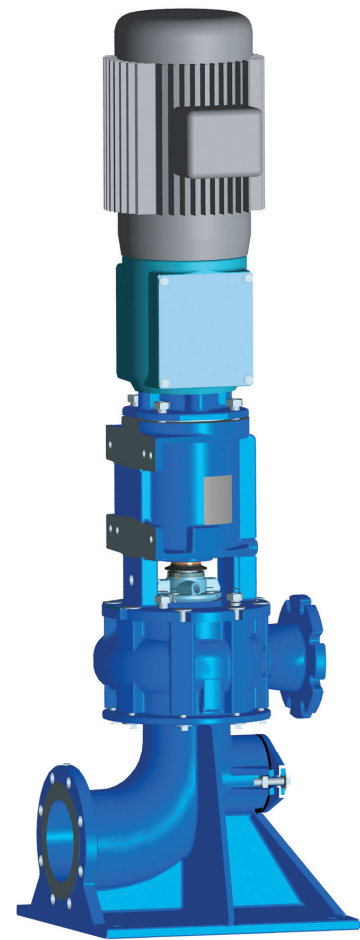

Vertical

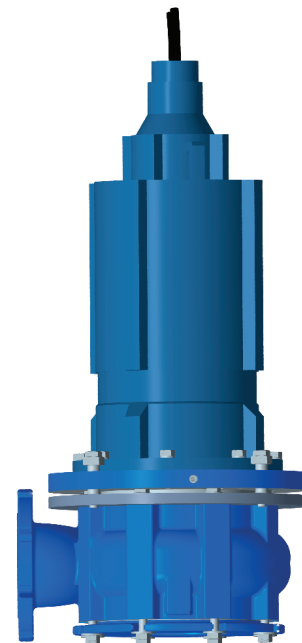

Submersible

The WEMCO® Model CF™ Chop-Flow™

Designed from the start as a WEMCO® pump, the new Chop-Flow pump is the same kind of user-friendly pump you've trusted from WEMCO for over 50 years - rugged, reliable, dependable, and maintenance-free!

- High hydraulic efficiency.
- Wrap around nose vanes insure effective chopping at the center of the impeller, without the need for an impeller nut.
- A one-piece, easily replaceable, ridged cutter bar spans the entire suction opening.
- Rear pump out vanes with cutting slots repel and chop any material that gets behind the impeller.
- The wearing parts - cutting bar and rear cutting teeth - are easily and inexpensively replaceable.
- All clearances are easily and externally adjustable, by one person without the hassle to unbolt and move the pump and/or the motor as required by other designs.
- Top quality materials and castings throughout - no flimsy fabricated parts to corrode.
- Although the pump is completely new technology, it is dimensionally interchangeable with your present pump. Simply remove the old technology, and the Chop-Flow will bolt up to your existing piping and coupling.
- Available with packing and all conventional mechanical seals, flushed or flushless.

Chop-Flow™ Performance Curves

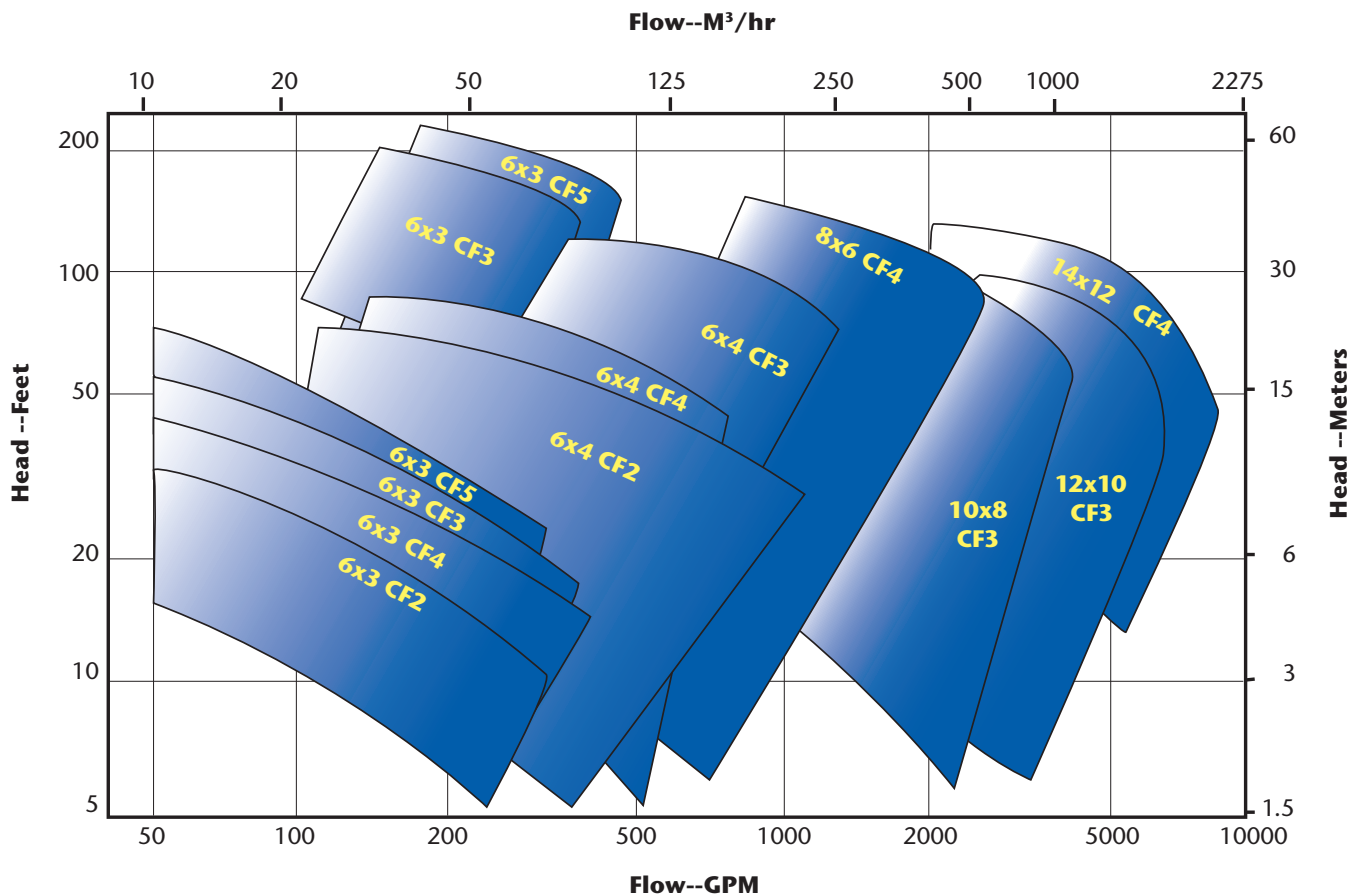

Wemco® Chop-Flow™ Pump -Close-Up Details

WEMCO® Chop-Flow™
Suction Inlet

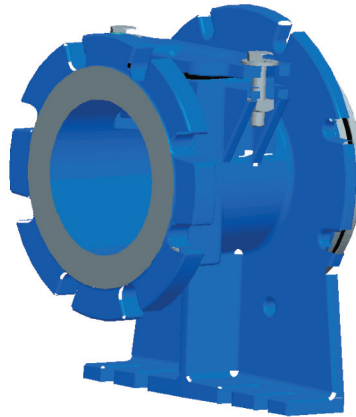

WEMCO® Chop-Flow™
Casing and Impeller

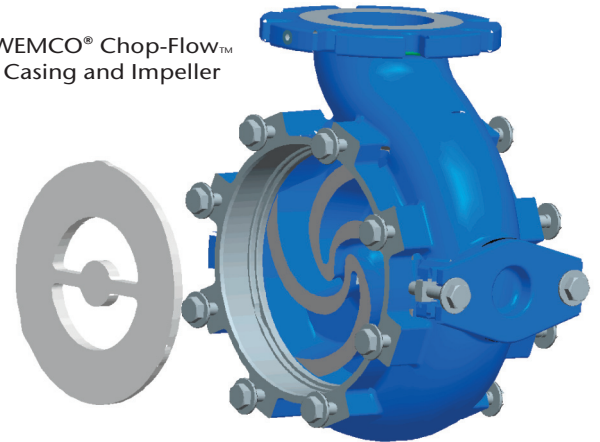

WEMCO® Chop-Flow™
Cutting Plate



Cast Cleanout

Cast iron for rigidity and corrosion resistance

The inlet:

- Heavy, thick casting for rigidity and corrosion resistance. No flimsy fabrications that can distort or corrode.
- Provides a smooth, slightly tapered transition for the flow, channeling solids to the cutter bar/impeller, - without dead spots and recirculation caused by the fabricated inlets of competitive units.

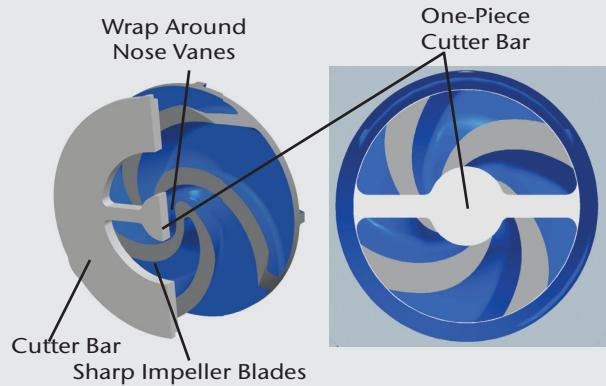

Front Side - Chop-Flow™ Impeller & Cutter Bar

- Patent pending chopper/impeller
 - Chops stringy material and solids as it runs against the stationary cutter plate and is moved through the pump casing with its highly efficient vane design.
 - Has nose vanes that completely wrap around the center of rotation, pulling material into the cutting area and assuring positive and complete chopping action.
 - Made of tough and hard ASTM A148 steel, hardened to RC60.
 - Has ultra sharp blade face that maintains a cutting edge as it wears, coupled with a generous and easily adjustable wear allowance to maintain optimum chopping over the life of the impeller.
- The stationary cutter bar
 - Single piece – easily removable, replaceable and economical as well.
 - Made of T-1 tool steel, as tough and hard as the impeller at RC60 for maximum wear resistance.

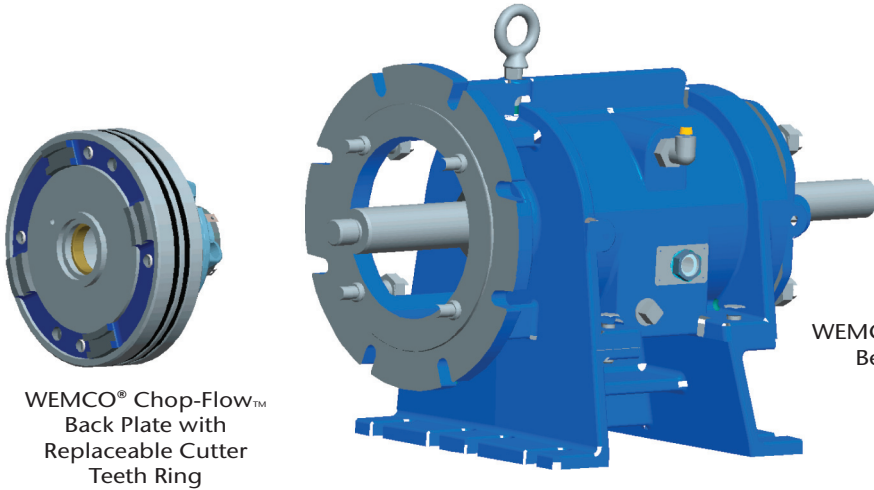

WEMCO® Chop-Flow™
Back Plate with
Replaceable Cutter
Teeth Ring

WEMCO® Chop-Flow™
Bearing Frame

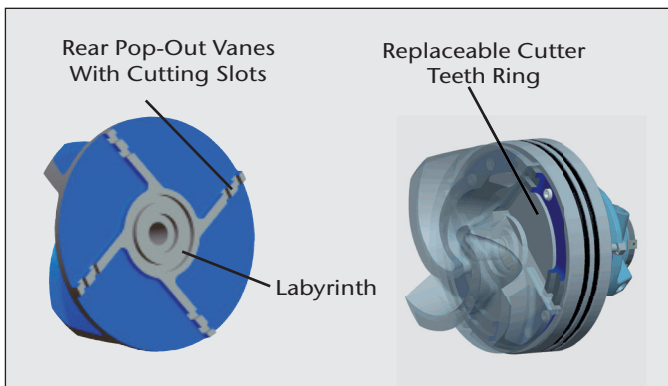

Rear Pop-Out Vanes
With Cutting Slots

Replaceable Cutter
Teeth Ring

Labyrinth

Impeller Reverse Side and Back Plate

- On the back side, patent-pending rear cutter action and a labyrinth to protect and prevent any material from reaching the seal area, whether the pump is running or not.
- When running, the large back pump-out vanes on the rear shroud of the impeller “pump-out” any material which tries to enter the area between the rear of the impeller and the backplate. These back vanes also incorporate 2 cutting slots which intermesh with replaceable cutting teeth on the backplate.
 - The pumping action/agitation of the vanes in combination with the chopping actions of the cutting slots insure that any material in this area will be positively ejected and won't reach the seal area.
 - The exclusive replaceable cutting teeth (patent- pending) on the back plate are easily and inexpensively replaced when necessary, eliminating the need to buy the very expensive, complete backplate assembly of competitive designs.
- A close-clearance labyrinth protects the seal area when the pump is not running.

Simple 2 step clearance adjustment with external adjusting screws!

- Step 1** Adjust bearing assembly and impeller forward to set clearance with cutter bar.
- Step 2** Adjust backplate to the impeller.

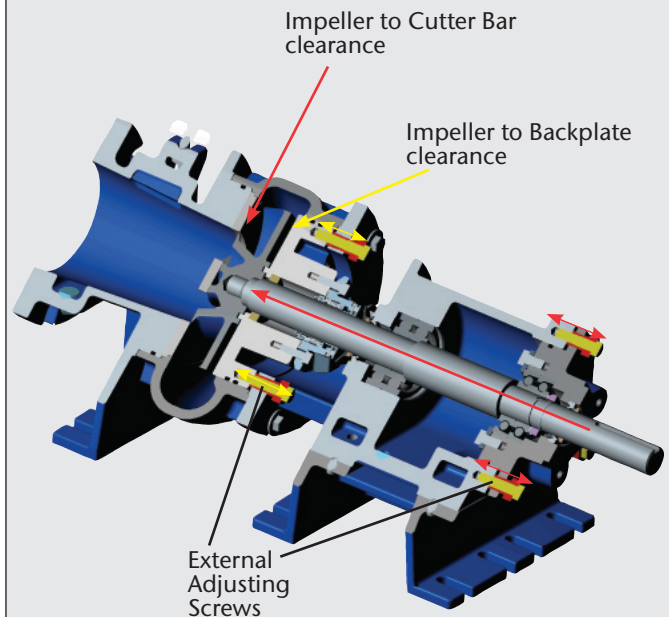

Impeller to Cutter Bar
clearance

Impeller to Backplate
clearance

External
Adjusting
Screws

Nothing could be easier!

The WEMCO® Model CF™ Chop-Flow™ pump complements the WEMCO® Torque-Flow® and WEMCO®-Hidrostal® pumps you probably already have installed!

There's no need to consult a dozen companies for the specialized pumps & equipment needed to transport raw sewage or sludge in your wastewater treatment plant. Nor do you have to use a so-called "do-it-all" pump from one company.

WEMCO pump has the expertise developed from over 50 years of experience and applications know-how, and has designed a pump for every application of sludge processing. No other pump company comes close.

The new Chop-Flow CF_™ pump is just the newest addition to the WEMCO® line of pumps and pumping or degritting systems, which handle tough solids efficiently, from lift stations to dewatered sludge. Every WEMCO® pump is specially designed to be the best pump for a specific application to ensure clog-free, wear-resistant, long-lasting performance.

Our pumps move sewage, fibrous material, grit and all types of sludge from raw to digested - thick, thin, even dewatered. They do it routinely with no fuss, no mess, no hassle.

Our WEMCO®-Hidrostal® prerotation pumping system automatically adjusts discharge volume to varying inflow rates with the use of constant speed motors. The system easily handles wide fluctuations in flow rates due to varying diurnal flows, storm run-off, and lift station services.

The WEMCO® Hydrogritter® is a highly efficient system for removing and dewatering grit from influent and primary sludge.

Let us help you select the best pumps or systems for your specific wastewater applications. When it comes to wastewater treatment know how, the only name you need to know is WEMCO®. Wastewater and sludge handling is our business!

WEMCO® Has The Right Pump!

Large Solids, Abrasive Solids, High Efficiency, Self-Priming or Chopping

- **Raw Sewage**
Lift stations, collection basins, CSO discharges, headworks, & our prerotation system skims & cleans the wet-well, too!
- **Screenings/Septage**
Pumps and/or chops raw concentrated solids, stringy materials, latex, organics, plastics, hair, or rags.
- **Clarifier Scum Pits**
Pumps and/or chops primary or secondary scum.
- **Primary Sludge**
Our abrasion-resistant WEMCO® Torque-Flow recessed impeller pumps are the right choice.
- **Return-Activated & Waste-Activated Sludge**
Nothing better than our high-efficiency, solids handling WEMCO®-Hidrostal® screw-centrifugal pumps.
- **Digester Service**
 - Mixing
 - High efficiency WEMCO®-Hidrostal® pumps for the lowest life-cycle costs of any pumps available for this application.
 - Our Model CF_™ Chop-Flow_™ pump for those services with nozzles to mix the digester.
 - Heat Exchanger Circulation - Through the heat exchanger, either our WEMCO®-Torque-Flow or WEMCO®-Hidrostal® pump, depending on the flow rate required, or the Model CF_™ Chopper pump, if required for chopping.
 - Transfer – Great application for the Chop-Flow_™ pump. Chops and conditions sludge before going to dewatering, and for larger flows, the WEMCO®-Hidrostal® pump is a cost-effective solution.
- **Thickened Sludge**
Any of our WEMCO® pumps for gravity-thickened sludges, depending on the flow and amount of abrasives present.



WEMCO® Self-Primer Pumps

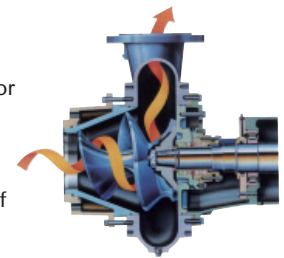

WEMCO®-Hidrostal® Screw Centrifugal Pumps

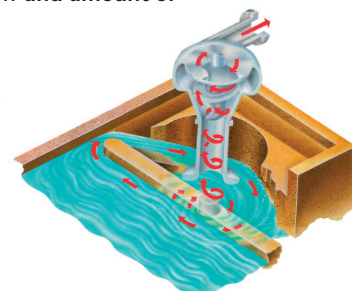
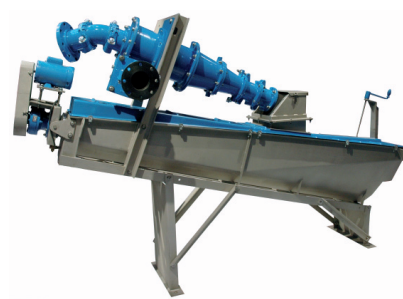

WEMCO® Pumps & Equipment In The Municipal Flow Diagram

- Model CF™ Chop-Flow™
- Model C™ Torque-Flow®
- Model CE™ Torque-Flow®
- Model E™ Torque-Flow®
- Muni-Flow® Rotary Lobe
- WEMCO® Self-Primer
- WEMCO®-Hidrostal® Screw Centrifugal
- WEMCO®-Hidrostal® Prerotation
- WEMCO Hydrogritter®

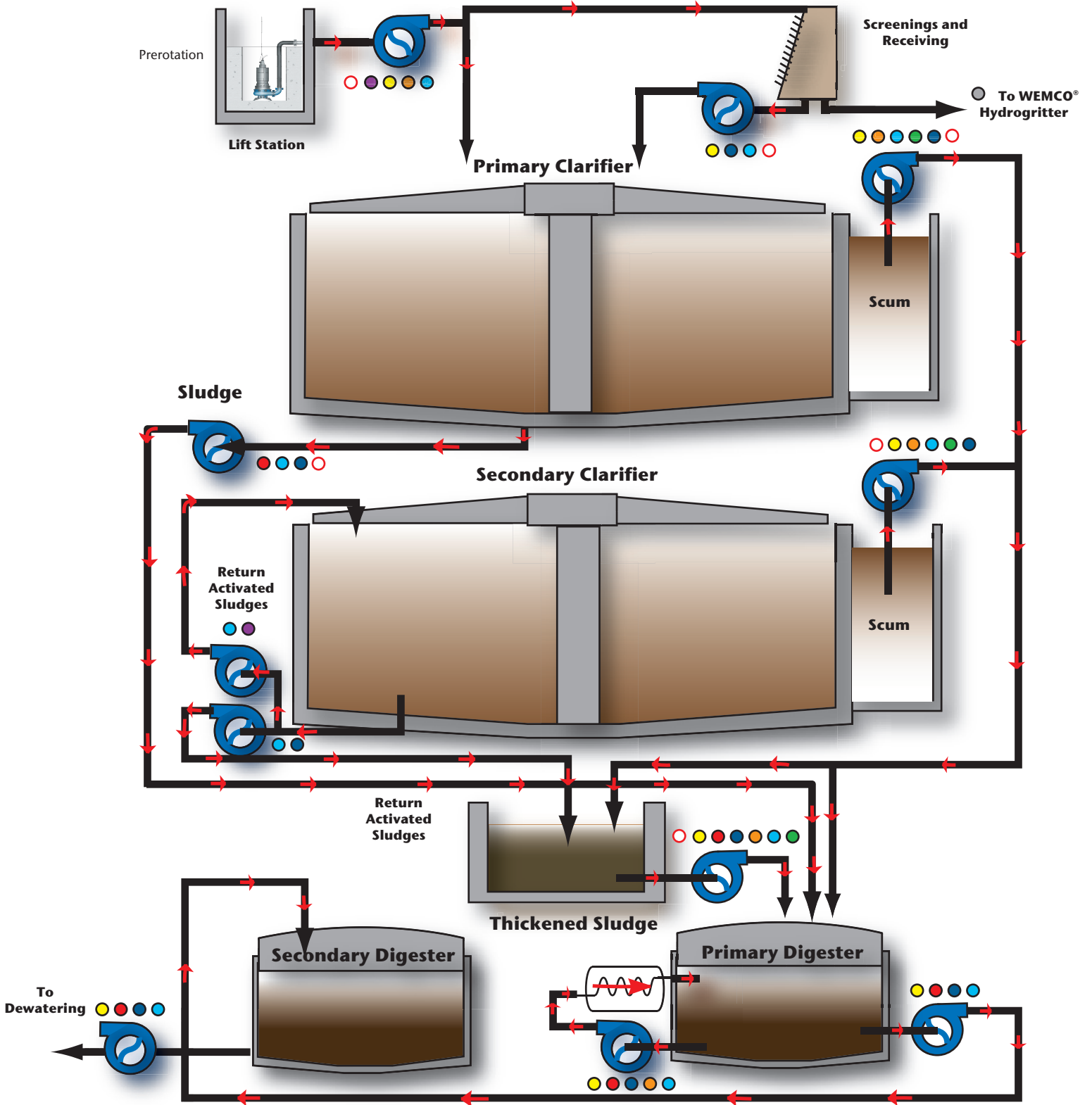

Chop-Flow Pump and Motor Dimensions

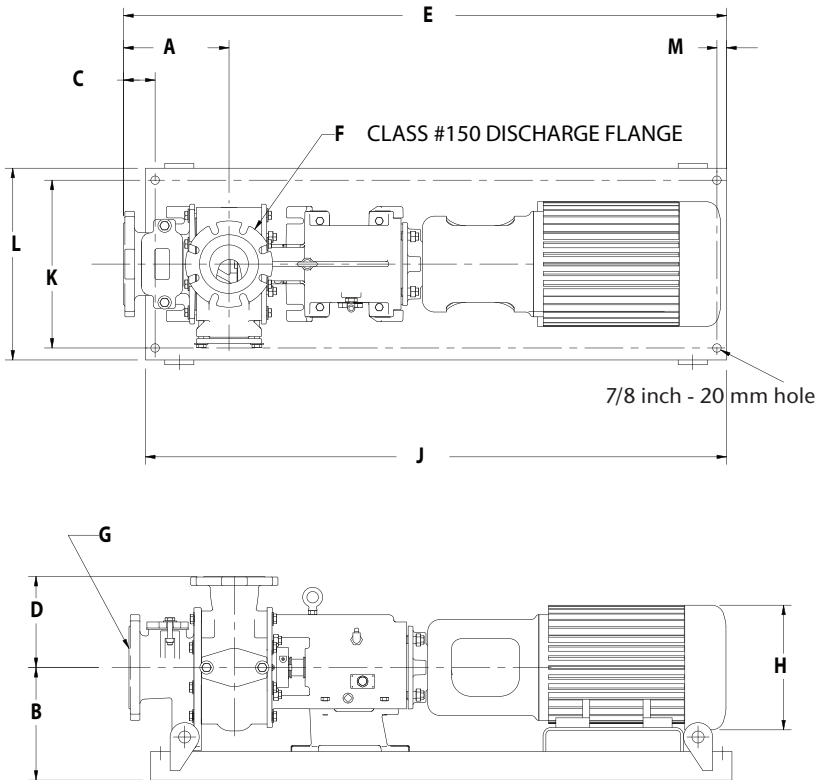

Not for construction, request certified prints.

HP	KW	Speed	Frame Size	H - Inches	H - mm
5	3.75	1170	215TC	10 1/4	260
		1750	184TC	8 11/16	221
7	5.2	1170	254TC	13	330
		1750	213TC	10 1/4	260
10	7.5	1170	256TC	13	330
		1750	215TC	10 1/4	260
15	11	1170	248YC	14 9/16	370
		1750	254TC	13	330
		3510	254TC	13	330
20	15	1170	286TC	14 9/16	387
		1750	256TC	13	330
		3510	256YC	13	330
25	19.2	1170	324TC	16 5/8	422
		1750	284TC	14 9/16	370
		3510	256TC	13	330
30	22.4	1170	326TC	16 5/8	422
		1750	286TC	14 9/16	370
		3510	284TC	14 9/16	370
40	30	1750	324TC	16 5/8	422
		3510	286TC	14 9/16	370
50	37	1750	326TC	16 5/8	422
		3510	326TCS	16 5/8	422
60	45	1750	364TC	18 3/4	476
75	56	1750	364/365TC	18 3/4	476
100	74	1750	404/405TC	21 5/16	541
150	111	1750	444/445TC	23 3/8	594

MODEL	A Inches mm	B Inches mm	C Inches mm	D Inches mm	E Inches mm	F In. mm	G In. mm	J In. mm	K Inches mm	L In. mm	M In. mm
6X3CF2 - 6X3 CF4	10 1/2 266	10 7/8 276	2 1/8 56	7 5/8 193	61 1/8 1555	3 76	6 152	60 1524	17 1/2 445	20 508	1 25
6X3CF3 - 6X3 CF5	10 1/4 260	10 7/8 276	1 3/8 34	8 5/8 218	60 3/8 1534	3 76	6 152	60 1524	17 1/2 445	20 508	1 25
6X4CF2 - 6X4 CF4	10 7/8 276	12 7/8 327	2 5/8 66	9 1/2 243	61 5/8 1543	4 102	6 152	60 1524	17 1/2 445	20 508	1 25
6X4 CF3L - 6X4 CF3H	10 3/8 270	12 7/8 327	1 3/4 44	11 1/2 292	60 3/4 1543	4 102	6 152	60 1524	17 1/2 445	20 508	1 25
8x6 CF4	11 5/8 270	12 7/8 327	3 3/8 87	12 304	62 3/8 1330	6 152	8 203	60 1524	17 1/2 445	20 508	1 25
10x8 CF4	12 13/16 325	18 1/2 470	5 3/4 267	17 3/4 566	100 1/4 2546	8 203	10 254	96 2438	27 1/2 850	30 925	1 1/2 38
12X10 CF6	13 3/8 325	24 1/4 482	13 3/8 267	23 566	101 1/4 2960	10 254	12 304	96 2438	28 927	31 1028	1 1/2 38
14X12 CF3	16 3/4 419	28 520	17 1/4 368	27 654	95 1/4 2960	12 304	14 355	96 2438	28 1002	31 1028	1 1/2 38

motralec

4 rue Lavoisier . ZA Lavoisier . 95223 HERBLAY CEDEX
Tel. : 01.39.97.65.10 / Fax. : 01.39.97.68.48
Demande de prix / e-mail : service-commercial@motralec.com

www.motralec.com

Excellent
Power & Industrial
Solutions

WEIR
POWER & INDUSTRIAL