

## Multistage High-Pressure 200MS Series Centrifugal Pumps



**motralec**

4 rue Lavoisier . ZA Lavoisier . 95223 HERBLAY CEDEX

Tel. : 01.39.97.65.10 / Fax. : 01.39.97.68.48

Demande de prix / e-mail : [service-commercial@motralec.com](mailto:service-commercial@motralec.com)

[www.motralec.com](http://www.motralec.com)

**SPX**®

# 200MS Series High-Pressure Multistage Centrifugal Pumps:

The introduction of the Waukesha Cherry-Burrell 200 Series, Heavy-Duty Centrifugals set a new standard for higher efficiency, minimal vibration and longer life.

Many of the same features of the 200 Series pumps, including strong investment cast impellers, low NPSH requirements and tighter running clearances, have been included in the 200MS high-pressure multistage.

Especially designed for recirculating service in reverse osmosis and other membrane systems, the 200MS Series pumps offer lower start-up and run costs due to the high efficiency two impeller design. Moreover, they produce a smooth, constant flow rate that reduces RO membrane fouling.

The 200MS Series pumps are equipped with a balanced, double-shaft seal with buffer fluid ports on top and bottom for complete removal of air/vapor from the seal chamber.

## The smoother flowing, high-efficiency, cost saving alternative for high-pressure applications

### Operating Features

- Cost competitive two stage design.
- High efficiency and low noise; precision, heavy-duty, machined cover and diffuser manufactured to tight tolerances.
- Easier on RO membranes than piston pumps with a smooth, constant, flow rate and less membrane fouling.
- Up to 250 psi pump differential pressure.
- Up to 1250 psi maximum casing pressure when pumps are placed in series.
- Sanitary 3A construction for dairy and food processing; wet end parts 316L stainless steel.
- CIPable.
- Save on maintenance costs; uses many common components with 200 Series pumps; easy takedown and assembly shortens downtimes.
- Flush type seal, standard.

### Long-life features

- Negligible shaft deflection due to rigid shaft.
- Large, long-life bearings with non-wearing, labyrinth seals.
- Coupling wear reduced by motor flange adapter design.



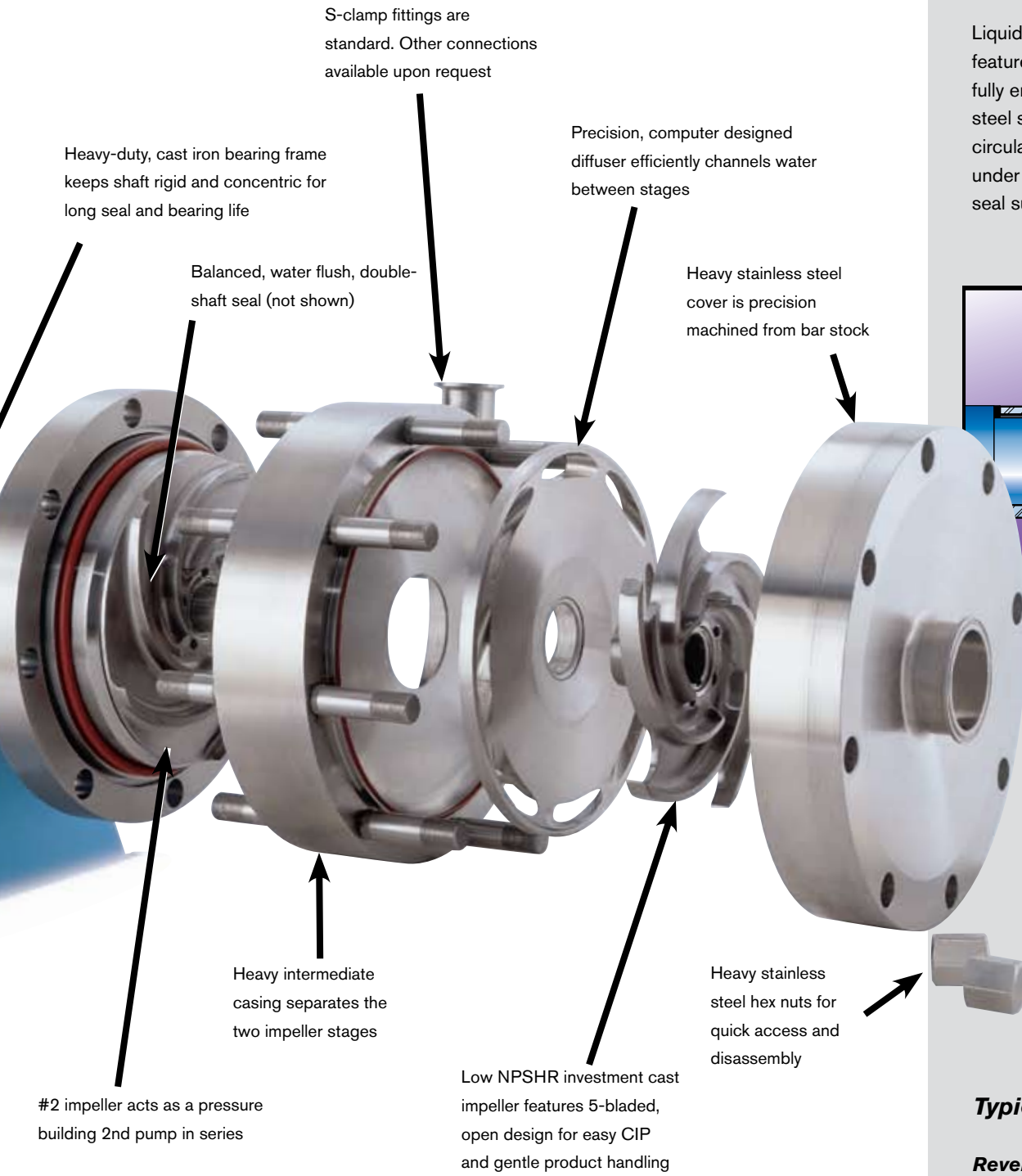

**Balance, double-shaft seal**

Liquid-cooled rotary, double seal features two silicon carbide seals fully enclosed with a stainless steel seal housing. Liquid coolant circulates through the housing under moderate pressure to cool seal surfaces.

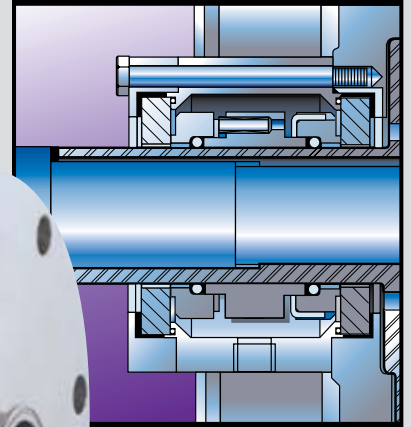

**Typical product applications**

**Reverse Osmosis systems**

- Whey Separation
- Food plant waste streams
- Water treatment

**Water boost & recirculation in commercial buildings**

**Sanitizing systems**

**Machine coolants**

# Performance Curves

PERFORMANCE CURVES MODEL 2085MS - 8.5" @ 3500 RPM

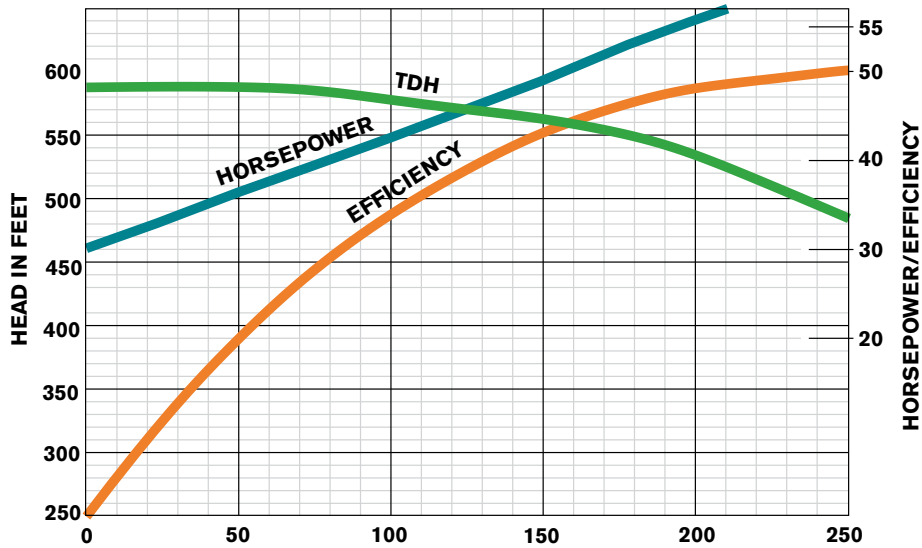

## 2085MS Dimensions

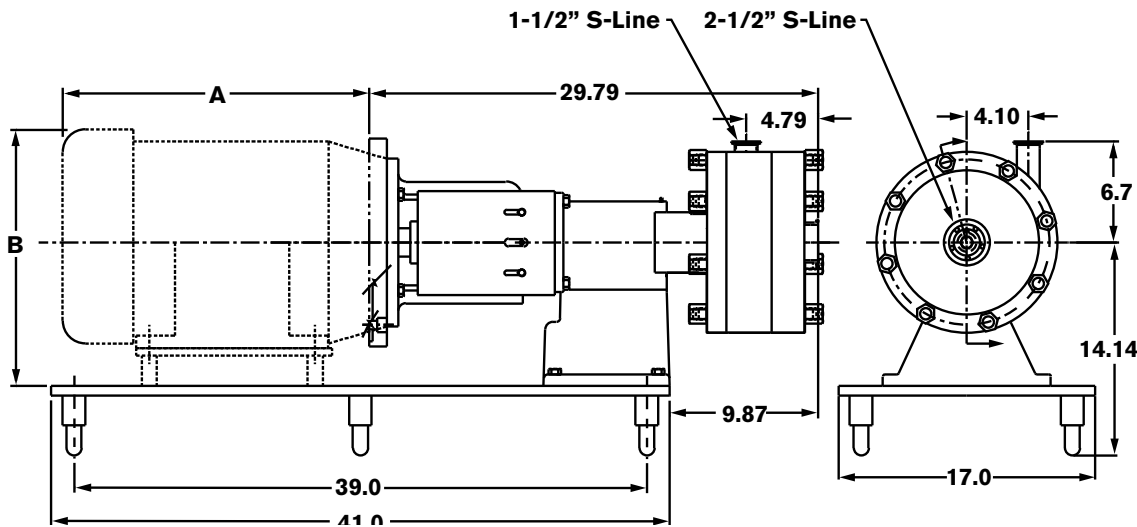

HP	Frame	A Inches (mm)	B Inches (mm)
20	256TC	19.75 (502)	16.15 (410)
25	284TC	20.25 (514)	21.95 (558)
30	286TC	21.75 (552)	22.70 (577)
40	324TC	23.50 (570)	23.90 (607)
50	326TC	25.00 (635)	24.60 (625)
60	364TC	25.70 (653)	25.30 (643)



**motralec**

4 rue Lavoisier . ZA Lavoisier . 95223 HERBLAY CEDEX

Tel. : 01.39.97.65.10 / Fax. : 01.39.97.68.48

Demande de prix / e-mail : [service-commercial@motralec.com](mailto:service-commercial@motralec.com)

[www.motralec.com](http://www.motralec.com)

**SPX**®

PROCESS EQUIPMENT