

# VIKING PUMP

A Unit of IDEX Corporation

Viking® SG Series External Gear Pumps

## High Pressure, High Reliability



The SG Series External Gear Pumps are designed for reliability in industrial applications through an extensive range of sizes and options with pressure capabilities up to 170 Bar (2,500 PSI).

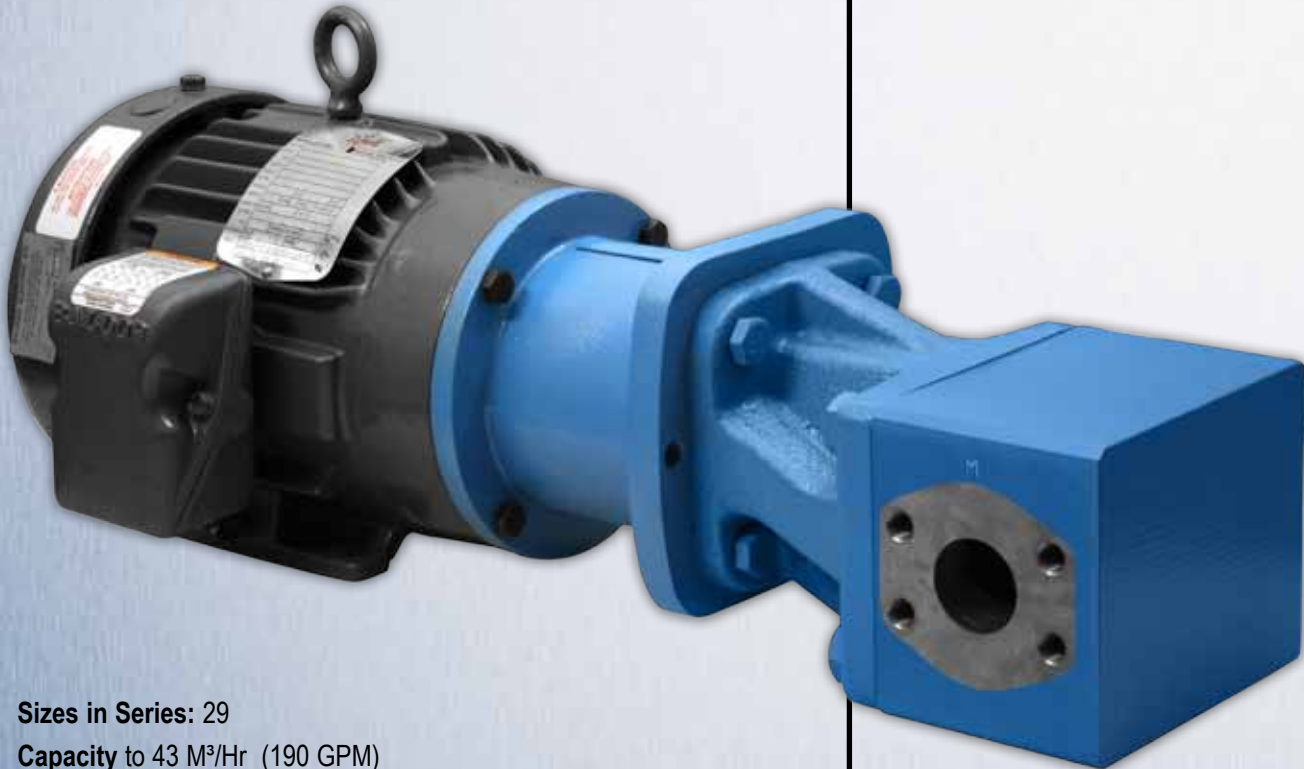

Sizes in Series: 29

Capacity to 43 M<sup>3</sup>/Hr (190 GPM)

Pressure to 170 Bar (2,500 PSI)

Viscosity 0.1 to 1,000,000 cSt

Temperature -40°C to +230°C (-40°F to +450°F)

**IDEX**  
CORPORATION

[www.motralec.com](http://www.motralec.com) / [service-commercial@motralec.com](mailto:service-commercial@motralec.com) / 01.39.97.65.10

# Viking® Lower Cost of Ownership by Design

Viking SG Series External Gear Pumps deliver longer seal and bearing life by preventing shaft movement and wear that cause competitors' pumps to fail prematurely.

## The Viking Advantages

For almost 100 years, Viking Internal Gear pumps have been known for reliability. For 35 years, Viking SG Series External Gear pumps have followed in that proud tradition, with the advantages of higher developed pressures and higher speeds.

SG Series pumps were designed to ensure reliability in industrial process applications. Because seal leakage is the most frequent cause of pump downtime, the SG Series minimizes shaft movement to significantly lengthen seal life. Radial (side-to-side) movement, or misalignment, is prevented by close coupled motor mounts or outboard bearings for foot-mounted pumps. Axial (back-and-forth) movement is minimized by spur-type gears, instead of helical gears which cause gear thrust on mating components. As standard equipment, the SG Series' anti-friction needle bearings eliminate wear that journal bearings experience at startup and shutdown - when the hydrodynamic film of liquid is absent. SG series pumps have an extensive range of options to ensure the right seals, bearings and other features for the application.

## SG Series Value vs. Competitors

The Value of Reliability is Clear.

Assuming the cost of:

- Downtime,
- Lost production, and
- Lost process revenue at \$10,000 per hour in a typical process plant...

**Simply by providing 20% longer seal and/or bearing life than competitors' pumps by minimizing radial and axial shaft movement, Viking's SG Series can save you more than \$8,000 per year, or \$40,000 over five years.**

A customized scenario needs to be adapted to fit each customer's application and operating parameter. The accuracy of the calculated savings depends upon the accuracy of customer supplied data. Note that pump configuration and materials used for pumps varies with application. And that pumps should only be used for the particular application with the particular liquids specified when pumps are ordered.



SG-40514  
pump with footed bracket



SGN-0732

## Performance Envelope

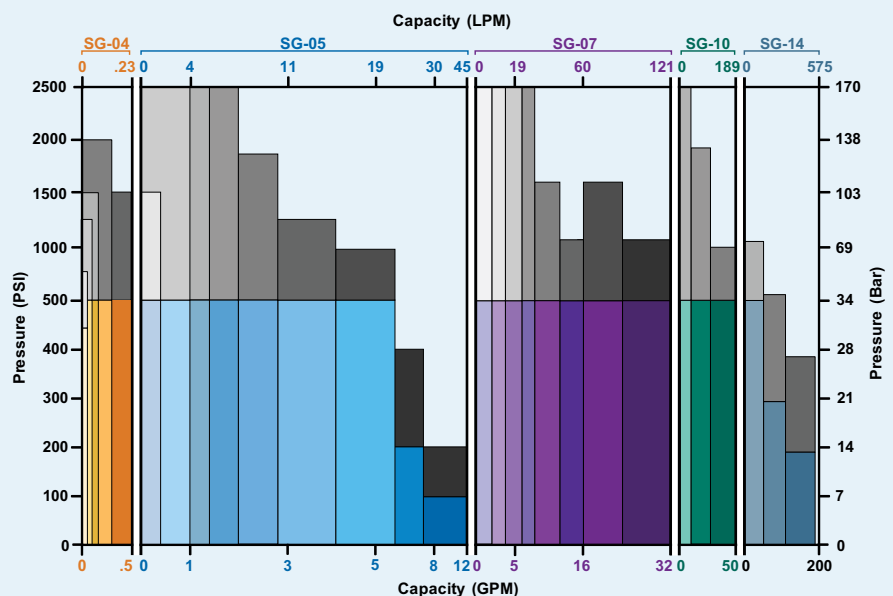

Note: Colored portion is Continuous Duty, Grey portion is Intermittent Duty.

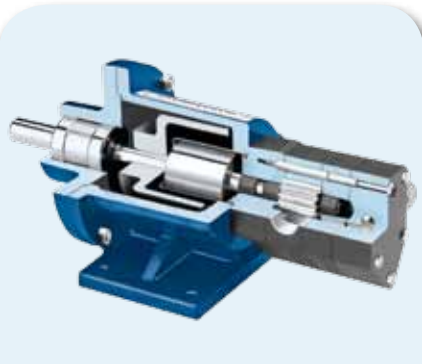

## SG Series External Gear Benefits Compared to Other Gear Pumps :

- Variety of sealing options including sealless Viking Mag Drive<sup>®</sup> to reduce risk of leakage
- Close-coupled motor mount, foot bracket, and base-mounting options available to match space or motor requirements
- Anti-friction needle bearings provide high pressure capabilities with higher efficiency and lower wear than journal bearings.
- Hardened gears and shafts offer long-life performance
- UL, NSF, CE and ATEX listing available on select models
- Compact, rugged design provides an excellent value with industry leading versatility.
- Multi-section pump configurations offer two or more flow rates operating from single power source, reducing equipment costs

## Typical Liquids Handled by Viking<sup>®</sup> External Gear Series Pumps



- **Oils** (e.g. Edible Oils, Fats, Grease, Lube Oil, Mineral Oil, Synthetic Oil, Transformer Oils)
- **Fuels** (e.g. Additives, Diesel, Ethanol, Fuel Oil, Gasoline, Jet Fuel, Kerosene Mercaptans, Methanol, Propane)
- **Adhesives, Sealants and Polymers** (e.g. Epoxy Resin, Formaldehyde Resin, Methyl Methacrylate, Polymethylene Wax, PVC, Silicone Sealant, Window Glazing)
- **Polyurethanes** (e.g. Cyclopentane, MDI, Polyol, TDI)
- **Paints, Inks and Coatings** (e.g. Dyes, Inks, Ink Oil, Paint Pigments, Urethanes, Varnish)
- **Petroleum** (e.g. Bitumen, Crude Oil, Naptha, Propylene, Gas Oil)
- **Solvents** (e.g. Acetone, Toluene, Dimethylbenzene)
- **Heat Transfer** (e.g. Ammonia, Ethylene Glycol, Freons, Isobutene, Heat Transfer Oils, Propylene Glycol)
- **Chemicals** (e.g. Butylamine, Epichlorohydrin, Ethanolamine, Ethylenediamine, Furfural, Pyridine)

## Viking External Gear Series Pumps in Specialty Applications



Centralized Lubrication Systems



Engine Direct-Drive Machine Lube



Polyurethane Metering/Mixing



Burner Feed



Machine Tool Coolant Feed



Compressor Lubrication



Heat Transfer



Hot Oil Fryers



Pipeline Sampling



Adhesive & Sealant Dispensing

# Viking® Benefits

## ADVANCED DURABILITY

### ■ Anti-Friction Needle Bearings

Needle bearings with high load carrying capacity standard, eliminates sliding between bearing surfaces to minimize friction and wear. **Reduces lubrication and service requirements while providing a significant increase in bearing life for lower cost of operation.**

### ■ Hardened Steel Gears and Shaft

Heat treated shaft and spur-type gears minimize wear while increasing service life of pump. **Extends pressure capability while minimizing wear for longer pump life.**

### ■ Clearance Options

Reduced clearances for thin liquids, standard clearances for medium viscosities, and extra clearances for viscous liquids and high temperatures. **Ensures "best" performance for the application.**

### ■ Pressure Relief Valve (not shown)

Prevents over pressurization. **Protects pump during process upset conditions.**

### ■ Motor Brackets

Brackets for all pump sizes and most NEMA, IEC, Air and Hydraulic motors prevent misalignment. Optional foot mount shaft heights match Viking reducer shaft heights. **Provides quicker, easier installations into virtually any system.**

### ■ Port Positioning Options

Opposite porting can be oriented in horizontal or vertical installation. **Easily adapted to existing piping layout, with in-line ports.**

## EASY INSTALLATION

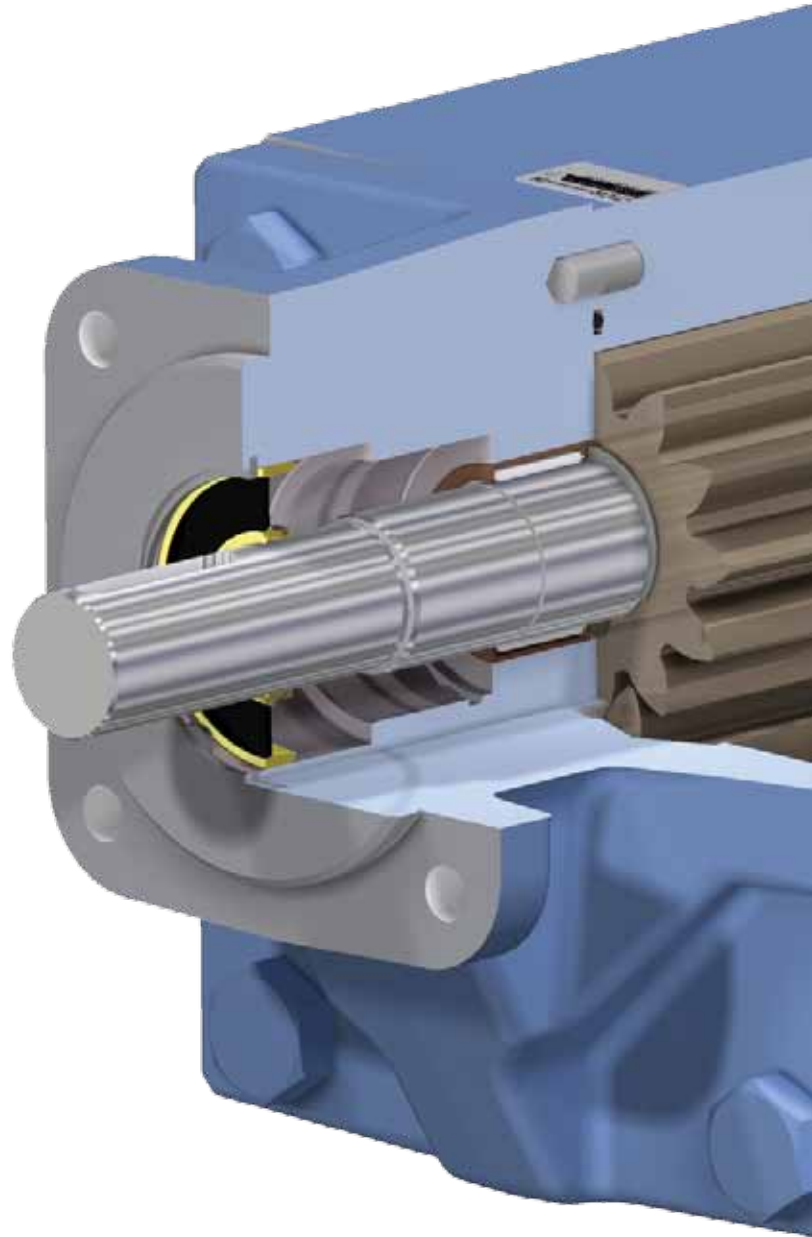

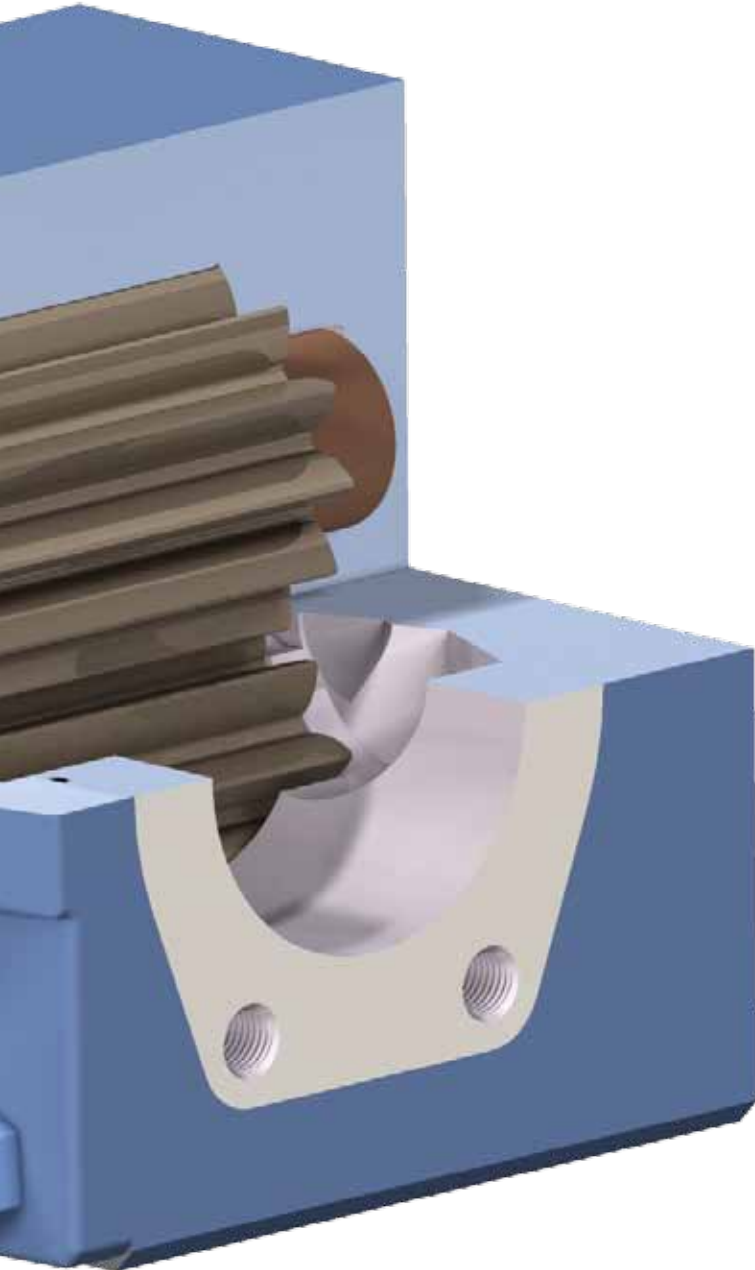

### ■ Sealing Options

Compact units can be fitted with many seal options to match application requirements. **Pump and seal configuration matched to need, providing longest possible pump life.**

### ■ Optional Journal Bearings

Optional carbon graphite journal bearings available for very low viscosities, or silicon carbide bearings for abrasives. **Allows "best" bearing selection for pump configuration matched to application.**

### ■ High Pressure Capabilities

Exceeds pressure ratings of most other gear pumps. **Provides economical, compact pump that delivers capacity at high pressure.**

### ■ Multi-Section Pumps with Multiple Porting Options

Two or more separate pumping sections driven by single source can be configured with separate ports or common suction or common discharge ports. **Each section can operate at different pressures and or flows, making them very adaptable to unique pumping applications.**

### ■ High Speed Design

SG Series maximizes flow capabilities within a compact design at standard motor speeds. **Eliminates reducer in most cases for lower installation cost.**

### ■ Compact, Close-Coupled Design

Saves valuable floor space and provides a smaller envelope. **Easy to install in tight spaces or adapt to OEM equipment.**

### ■ Sealless Mag Drive Option

Eliminates shaft seal leakage to minimize housekeeping, maintenance and environmental compliance costs. **Eliminates dynamic seals for a lower total cost of ownership.**

APPLICATION FLEXIBILITY

LOWER COST OF OWNERSHIP

# Materials of Construction

## SG-04, SG-05, SG-07, SG-10 & SG-14 Series External Gear Pump Construction

Component	Standard SG-04, -05, -07	Standard SGN-05, -07	Standard SG-10, -14	Options
Bracket	Cast Iron ASTM A823	Ductile Iron ASTM A536	Cast Iron ASTM A48	Surface Hardening (Vitek)
Casing	Cast Iron ASTM A823	Ductile Iron ASTM A536	Cast Iron ASTM A823	Surface Hardening (Vitek)
Head, Separation Plate	Cast Iron ASTM A823	Ductile Iron ASTM A536	N/A	Surface Hardening (Vitek)
Relief Valve Body	Cast Iron ASTM A823	Ductile Iron ASTM A536	Cast Iron ASTM A48	---
Relief Valve Poppet	Hardened Steel	Hardened Steel	Ductile Iron ASTM A536	---
Relief Valve Spring	Steel ASTM A229	Steel ASTM A229	Chrome Silicon Spring Steel ASTM A401	---
Gears	Heat Treated Steel	Heat Treated Steel	Heat Treated Steel	PPS (composite)
Shafts	Heat Treated Steel ASTM A322	Heat Treated Steel ASTM A322	Heat Treated Steel ASTM A322	---
Anti-Friction Needle Bearings ①	Bearing Steel	Bearing Steel	Bearing Steel	---
Journal Bearings	---	---	---	Carbon Graphite ②, High Temp Carbon Graphite, Silicon Carbide ③
Outboard Ball Bearing ⑤	---	---	---	Bearing Steel
O-Rings	Buna-N	Buna-N	Buna-N	Neo., Viton®, PTFE, Kalrez®
Lip Seals	Buna-N	Buna-N	Buna-N	Neo., Viton®, PTFE
Component Mechanical Seals	Carbon/Ni-Resist	Carbon/Ni-Resist	Carbon / Silicon Carbide	Carbon / Silicon Carbide, Silicon Carbide/Silicon Carbide
Canister ④	316L Stainless Steel	316L Stainless Steel	316L Stainless Steel	Hastelloy® C22
Magnetic Coupling ④	Cast Iron	Cast Iron	Cast Iron	---
Magnets ④ <small>(Outer magnets nickel plated, inner magnets sealed in SS canister)</small>	Neodymium Iron Boron	Neodymium Iron Boron	Neodymium Iron Boron	Samarium Cobalt
"B" Drive Foot Bracket	Cast Iron ASTM A48	Cast Iron ASTM A48	Cast Iron ASTM A48	---
"M" Drive Motor Bracket	Cast Iron ASTM A48	Cast Iron ASTM A48	Aluminum	---

① Needle bearings standard with lip seals.

② Carbon graphite journal bearings standard with mechanical seals or sealless mag drive series.

③ Tungsten-carbide coated shafts recommended with silicon carbide journal bearings.

④ Sealless mag drive version

⑤ Standard with mechanical seal (SG-10,-14 only), optional with lip seal on all sizes.

Kalrez® is a registered trademark of DuPont Performance Elastomers.

Viton® is a registered trademark of DuPont Performance Elastomers.

Hastelloy® is a registered trademark of Haynes International, Inc.

Viking® is a registered trademark of IDEX Corporation.

## Model Number Key - Single Pumps

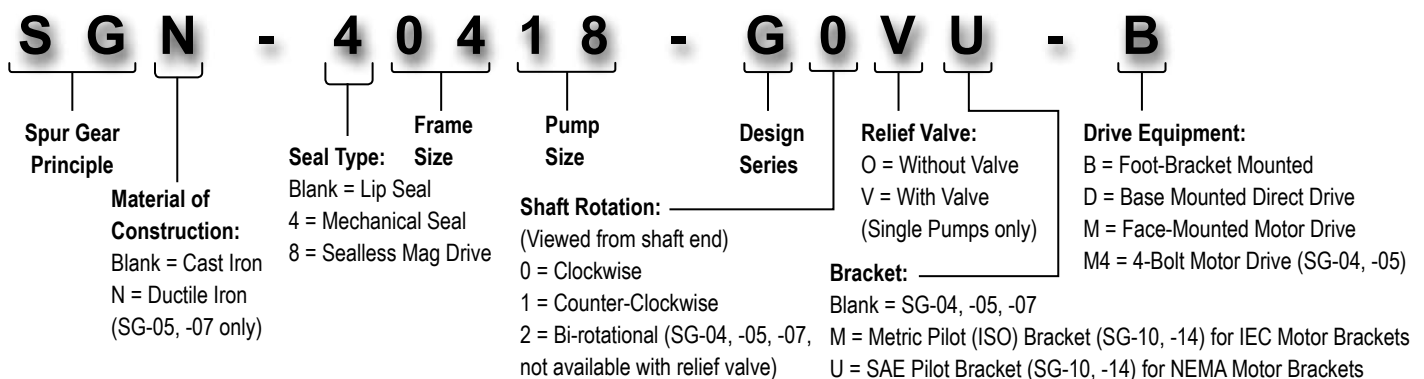

## SG-04, SG-05, SG-07, SG-10 & SG-14 Series Unmounted Single Pump Specifications

① Pump Model	Port Size	⑥ Nominal Capacity at 50 Hz Motor Speeds		⑥ Nominal Capacity at 60 Hz Motor Speeds		Maximum Continuous Pressure		Maximum Intermittent Pressure		② Maximum Recommended Temperature		Approximate Shipping Weight (Pump Only)	
		1450 RPM		1750 RPM		BAR	PSI	BAR	PSI	Deg. C	Deg. F	kg.	lb.
		LPM	GPM	LPM	GPM								
SG-0417	0.375" ④	0.19	0.05	0.23	0.06	34	500	52	750	230	450	2.7	6
SG-0418		0.44	0.12	0.53	0.14	34	500	86	1250	230	450	2.7	6
SG-0425		0.56	0.15	0.68	0.18	34	500	103	1500	230	450	2.7	6
SG-0435		0.85	0.22	1.02	0.27	34	500	121	1750	230	450	2.7	6
SG-0450		1.13	0.30	1.36	0.36	34	500	138	2000	230	450	3.2	7
SG-0470		1.57	0.41	1.89	0.50	34	500	103	1500	230	450	3.2	7
③SG-0518	0.5" ④	2.2	0.58	2.6	0.7	34	500	103	1500	230	450	2.7	6
③SG-0525		3.1	0.83	3.8	1.0	34	500	170	2500	230	450	2.7	6
③SG-0535		4.4	1.16	5.3	1.4	34	500	170	2500	230	450	2.7	6
③SG-0550		6.3	1.66	7.6	2.0	34	500	170	2500	230	450	3.2	7
③SG-0570		8.8	2.32	10.6	2.8	34	500	124	1800	230	450	3.2	7
③SG-0510	0.75" ④	12.5	3.31	15.1	4.0	34	500	86	1250	230	450	3.6	8
③SG-0514		17.6	4.64	21.2	5.6	34	500	62	900	230	450	4.1	9
③SG-0519		23.8	6.30	28.8	7.6	14	200	28	400	230	450	4.5	10
③SG-0528	35.1	9.28	42.4	11.2	7	100	14	200	230	450	5	11	
SG-0729	1.0" ④	8.8	2.3	10.6	2.8	34	500	170	2500	230	450	6.4	14
SG-0741		12.5	3.3	15.1	4.0	34	500	170	2500	230	450	6.8	15
SG-0758		17.6	4.6	21.2	5.6	34	500	170	2500	230	450	7.7	17
SG-0782		25.1	6.6	30.3	8.0	34	500	155	2250	230	450	8.2	18
SG-0711		35.1	9.3	42.4	11.2	34	500	110	1600	230	450	8.6	19
SG-0716		50.0	13.0	61.0	16.0	34	500	76	1100	230	450	9.1	20
SG-0722	1.50" X 1.25" ④	69.0	18.0	83.0	22.0	34	500	110	1600	230	450	18.6	41
SG-0732		100.0	26.0	121.0	32.0	34	500	76	1100	230	450	19.5	43
SG-1009	1.0" ⑤	50.0	13.0	61.0	16.0	34	500	170	2500	230	450	20.5	45
SG-1013	1.5" ⑤	78.0	21.0	95.0	25.0	34	500	130	1900	230	450	22.1	49
SG-1026	2.0" ⑤	157.0	41.0	189.0	50.0	34	500	68	1000	230	450	24.5	54
SG-1420	2.0" ⑤	220.0	58.0	265.0	70.0	34	500	75	1100	230	450	59.1	130
SG-1436	3.0" ⑤	392.0	104.0	473.0	125.0	20	290	40	580	230	450	71.5	158
SG-1456	4.0" ⑤	597.0	158.0	719.0	190.0	13	190	26	380	230	450	85.8	189

① See model numbering code on Page 3 of this brochure. Performance is the same for SGN-05,-07 (ductile iron) models, or for SG-8-\_\_\_\_ (sealless mag drive models).

② Standard Buna-N seals (O-Rings and shaft lip seals) can be used from -40°F to +225°F (-40°C to +107°C). With optional sealing elements of PTFE or Kalrez®, temperatures up to +450°F (+230°C) are possible. Extra clearances may be required. Contact factory for recommendations.

③ UL 343 rating (-X) for fuel oil available.

④ NPT standard. Consult factory for other port size or type options such as BSP, SAE O-Ring or other.

⑤ SAE J518 Code 61 flange with metric fasteners standard. Consult factory for other port size or type options such as NPT, BSP, SAE O-Ring or other.

⑥ Nominal capacity based on 100 SSU (22 cSt) liquid at 100 PSI (7 BAR)

## Magnetic Coupling Torque Capacity

SG-04, -05 & -07 Magnetic Coupling Torque Capacity		
Coupling Size	Torque	
	FT-LBS	Nm
MD-A4	4	5.4
MD-A9	9	12.2
MD-B15	15	20.3
MD-B40	40	54.2

SG-10, -14 Magnetic Coupling Torque Capacity		
Coupling Size	Torque	
	FT-LBS	(Nm)
MD2-B14	14	19.0
MD2-B32	32	43.4
MD2-B50	50	67.8
MD2-C40	40	54.2
MD2-C90	90	122.0
MD2-C135	135	183.0
MD2-C180	180	244.0

Sealless magnetic drives are available on all SG and SGN pumps. Liquid is hermetically sealed in a containment canister at the bracket end of the pump. Outer magnets are positioned outside of the canister and are driven by the motor. Magnetic force passes through the canister and turns inner magnets inside the canister, connected to the pump drive shaft, to generate flow. Magnetic drives are especially useful for hazardous, volatile or flammable liquids where leakage or vapors are not allowable, or for high inlet pressures which would damage a shaft seal.

Contact your Viking distributor for assistance in selecting the right magnetic coupling for your pump. Several different torque ratings are available (see table on right) depending on the required flow, pressure and temperature. Neodymium Iron Boron magnets are used to +225°F (+107°C), and Samarium Cobalt magnets are used to +500°F (+260°C). Magnetic couplings offer either a long-coupled bearing carrier or NEMA or IEC face-mounted motor drive.

# Dimensions

## Dimensions for Viking SG Series Unmounted Single Pumps - Sizes SG-04 & SG-05

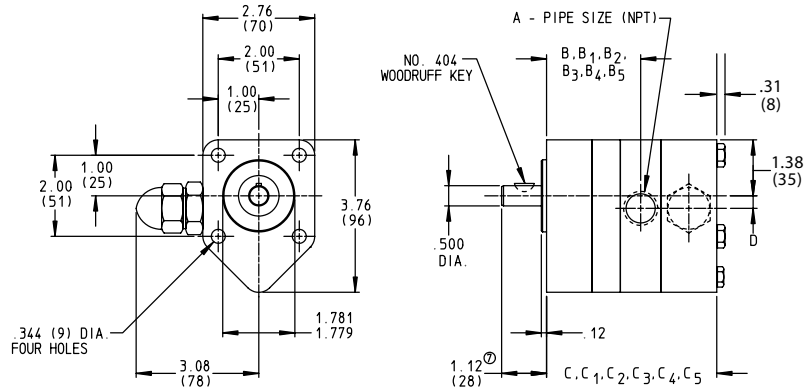

Model	A		B	① B1	② B2	③ B3	④ B4	⑤ B5	C	① C1	② C2	③ C3	④ C4	⑤ C5	D
SG-0417	3/8	mm	46	68	55	51	73	60	93	116	103	68	90	78	8
		in	1.80	2.68	2.18	1.99	2.87	2.37	3.68	4.56	4.06	2.68	3.56	3.06	0.31
SG-0418	3/8	mm	46	68	55	51	73	60	93	116	103	68	90	78	8
		in	1.80	2.68	2.18	1.99	2.87	2.37	3.68	4.56	4.06	2.68	3.56	3.06	0.31
SG-0425	3/8	mm	47	70	57	52	75	62	95	118	105	70	92	80	8
		in	1.87	2.75	2.25	2.06	2.94	2.44	3.75	4.63	4.13	2.75	3.63	3.13	0.31
SG-0435	3/8	mm	47	70	57	52	75	62	95	118	105	70	92	80	8
		in	1.97	2.85	2.35	2.16	3.04	2.54	3.85	4.73	4.23	2.85	3.73	3.23	0.31
SG-0450	3/8	mm	54	76	64	58	81	68	102	124	111	76	99	86	8
		in	2.12	3.00	2.50	2.31	3.19	2.69	4.00	4.88	4.38	3.00	3.88	3.38	0.31
SG-0470	3/8	mm	59	81	69	64	86	73	107	129	116	81	104	91	8
		in	2.32	3.20	2.70	2.51	3.39	2.89	4.20	5.08	4.58	3.20	4.08	3.58	0.31
SG-0518 SGN-0518	1/2	mm	46	68	55	51	73	60	93	116	103	68	90	78	8
		in	1.80	2.68	2.18	1.99	2.87	2.37	3.68	4.56	4.06	2.68	3.56	3.06	0.31
SG-0525 SGN-0525	1/2	mm	47	70	57	52	75	62	95	118	105	70	92	80	8
		in	1.87	2.75	2.25	2.06	2.94	2.44	3.75	4.63	4.13	2.75	3.63	3.13	0.31
SG-0535 SGN-0535	1/2	mm	50	72	60	55	77	65	98	120	107	72	95	82	8
		in	1.97	2.85	2.35	2.16	3.04	2.54	3.85	4.73	4.23	2.85	3.73	3.23	0.31
SG-0550 SGN-0550	1/2	mm	54	76	64	58	81	68	102	124	111	76	99	86	8
		in	2.12	3.00	2.50	2.31	3.19	2.69	4.00	4.88	4.38	3.00	3.88	3.38	0.31
SG-0570 SGN-0570	1/2	mm	59	81	69	64	86	73	107	129	116	81	104	91	8
		in	2.32	3.20	2.70	2.51	3.39	2.89	4.20	5.08	4.58	3.20	4.08	3.58	0.31
Ⓞ SG-0510 SGN-0510	1/2	mm	41	64	51	41	64	51	114	137	124	89	111	99	8
		in	1.62	2.50	2.00	1.62	2.50	2.00	4.50	5.38	4.88	3.50	4.38	3.88	0.31
Ⓞ SG-0514 SGN-0514	3/4	mm	46	69	56	46	69	56	124	147	134	99	121	109	5
		in	1.82	2.70	2.20	1.82	2.70	2.20	4.90	5.78	5.28	3.90	4.78	4.28	0.19
Ⓞ SG-0519 SGN-0519	3/4	mm	53	75	62	53	75	62	137	160	147	112	134	121	5
		in	2.07	2.95	2.45	2.07	2.95	2.45	5.40	6.28	5.78	4.40	5.28	4.78	0.19
Ⓞ SG-0528 SGN-0528	3/4	mm	46	69	56	46	69	56	160	182	170	135	157	144	5
		in	1.82	2.70	2.20	1.82	2.70	2.20	6.30	7.18	6.68	5.30	6.18	5.68	0.19

① These dimensions apply when the mechanical shaft seal option (outboard bearing) is selected.

② These dimensions apply when the overhung load option is selected.

③ These dimensions apply when the relief valve is deleted.

④ These dimensions apply when the relief valve is deleted and the mechanical shaft seal option is selected.

⑤ These dimensions apply when the relief valve is deleted and the overhung load option is selected.

Ⓞ These models have the ports in the casing. Others ported in separate plate.

⑦ When the overhung load option is selected the pump shaft extension becomes 1.62" (41mm).

Ⓢ Standard ports NPT. Optional threads include BSP and SAE O-ring J1453.

NOTE: Dimensions in parentheses are millimeters; others are inches.

## Dimensions for Viking SG Series Unmounted Single Pumps - Size SG-07

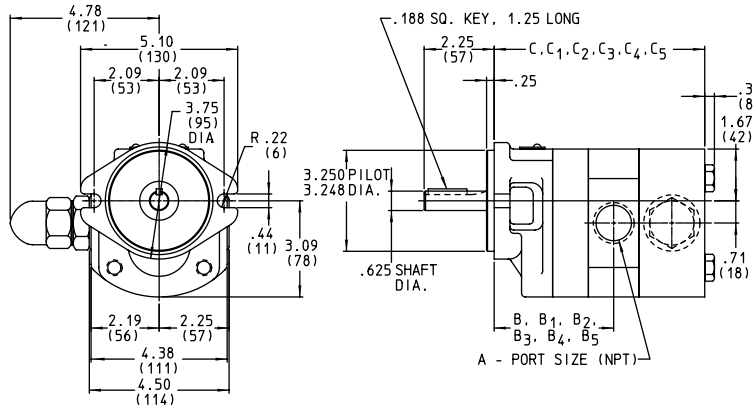

Model	A		B	① B1	② B2	③ B3	④ B4	⑤ B5	C	① C1	② C2	③ C3	④ C4	⑤ C5	D
SG-0741 SGN-0741	⑥ 1	mm	79	120	84	125	90	131	153	194	112	153	176	217	18
		in	3.10	4.72	3.29	4.91	3.54	5.16	6.03	7.65	4.41	6.03	6.91	8.53	0.71
SG-0758 SGN-0758	⑥ 1	mm	83	124	88	129	94	135	157	199	116	157	180	221	18
		in	3.27	4.89	3.46	5.08	3.71	5.33	6.20	7.82	4.58	6.20	7.08	8.70	0.71
SG-0782 SGN-0782	⑥ 1	mm	89	130	94	135	100	141	164	205	122	164	186	227	18
		in	3.51	5.13	3.70	5.32	3.95	5.57	6.44	8.06	4.82	6.44	7.32	8.94	0.71
SG-0711 SGN-0711	⑥ 1	mm	98	139	102	144	109	150	172	213	131	172	194	235	18
		in	3.84	5.46	4.03	5.65	4.28	5.90	6.77	8.39	5.15	6.77	7.65	9.27	0.71
SG-0716 SGN-0716	⑥ 1	mm	110	151	115	156	121	163	185	226	144	185	207	248	18
		in	4.34	5.96	4.53	6.15	4.78	6.40	7.27	8.89	5.65	7.27	8.15	9.77	0.71
SG-0722 SGN-0722	⑦ 1½ x 1¼	mm	109	150	109	150	---	---	265	306	224	265	---	---	18
		in	4.28	5.90	4.28	5.90	---	---	10.42	12.04	8.80	10.42	---	---	0.71
SG-0732 SGN-0732	⑦ 1½ x 1¼	mm	121	163	121	163	---	---	290	331	249	290	---	---	18
		in	4.78	6.40	4.78	6.40	---	---	11.42	13.04	9.80	11.42	---	---	0.71

- ① These dimensions apply when the mechanical shaft seal option is selected.
  - ② These dimensions apply when the relief valve is deleted.
  - ③ These dimensions apply when the relief valve is deleted and the mechanical shaft seal option is selected.
  - ④ These dimensions apply when the oversize port option (1½" NPT suction, 1¼" NPT discharge) is selected, with or without the relief valve.
  - ⑤ These dimensions apply when the oversize port option (1½" NPT suction, 1¼" NPT discharge) and the mechanical seal option are both selected, with or without the relief valve.
  - ⑥ Standard ports for these size pumps are 1" NPT. Oversize ports are available (1½" NPT suction, 1¼" NPT discharge) as an option on clockwise rotation pumps only. See footnotes 4 and 5 for appropriate dimensions. (See Price page P341.2). Optional threads include BSP and SAE O-ring J1453.
  - ⑦ Standard ports for these size pumps are 1½" NPT suction, 1¼" NPT discharge. These pumps are only available in clockwise rotation. Optional threads include BSP and SAE O-ring J1453.
- NOTE: SG-07 bracket to SAE-A 2-bolt standard for NEMA or IEC M-drive.  
NOTE: Dimensions shown in parentheses are millimeters; others are inches.

# Dimensions

## Dimensions for Viking SG Series Unmounted Single Pumps - Size SG-10

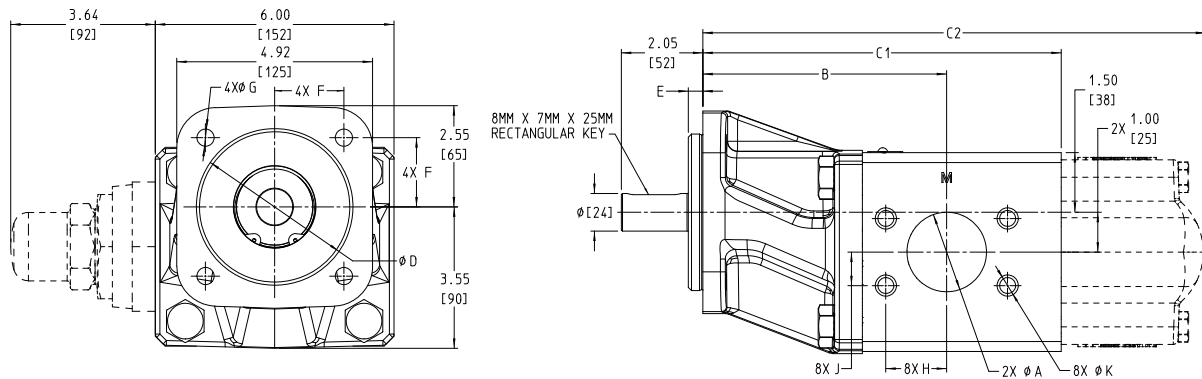

Model	Bracket Std. U or M		③ A	B	C1	C2	D	E	F	G	H	J	K
①SG-1009	M	mm	25	136	188	279	100	9.2	44.2	11	13	26	M10 x 1.50
②SG-1009	U	in	1.00	5.35	7.42	10.99	4.00	0.37	1.77	0.56	0.52	1.03	M10 x 1.50
①SG-1013	M	mm	38	150	204	295	100	9.2	44.2	11	35	18	M12 x 1.75
②SG-1013	U	in	1.50	5.91	8.04	11.61	4.00	0.37	1.77	0.56	1.38	0.70	M12 x 1.75
①SG-1026	M	mm	51	156	229	320	100	9.2	44.2	11	39	21	M12 x 1.75
②SG-1026	U	in	2.00	6.13	9.01	12.58	4.00	0.37	1.77	0.56	1.53	0.84	M12 x 1.75

① Bracket pilot to 100 mm ISO 3019-2 DIN 4x standard for IEC M-drive or foot bracket  
 ② Bracket pilot to SAE-B 4-bolt standard for NEMA M-drive or foot bracket

③ Standard ports SAE J518 code 61 flange. Optional tapped ports on same centerline include NPT or BSP (up to 2") or SAE O-Ring J1453 (up to 2")

## Dimensions for Viking SG Series Unmounted Single Pumps - Size SG-14

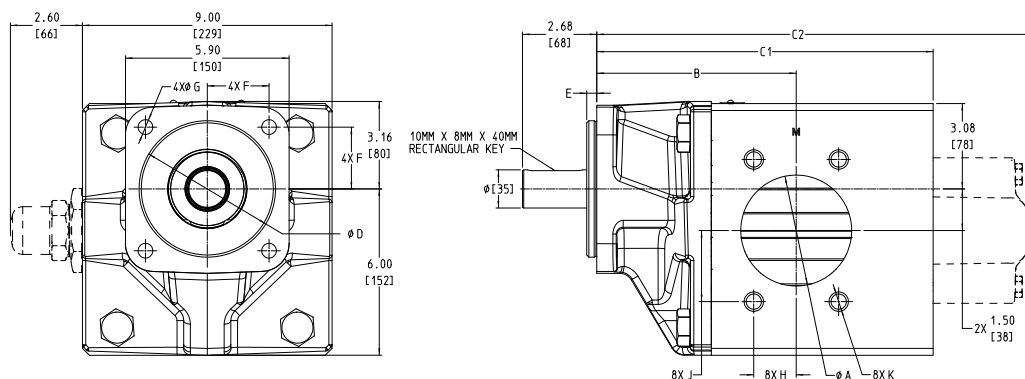

Model	Bracket Std. U or M		③ A	B	C1	C2	D	E	F	G	H	J	K
①SG-1420	M	mm	51	155	217	309	125	9.2	56.6	13.5	21	39	M12 x 1.75
②SG-1420	U	in	2.00	6.10	8.53	12.16	5.00	0.49	2.25	0.56	0.84	1.53	M12 x 1.75
①SG-1436	M	mm	76	173	257	350	125	9.2	56.6	13.5	31	53	M16 x 2.00
②SG-1436	U	in	3.00	6.80	10.13	13.76	5.00	0.49	2.25	0.56	1.22	2.09	M16 x 2.00
①SG-1456	M	mm	102	183	308	400	125	9.2	56.6	13.5	39	65	M16 x 2.00
②SG-1456	U	in	4.00	7.19	12.13	15.76	5.00	0.49	2.25	0.56	1.53	2.56	M16 x 2.00

① Bracket pilot to 125 mm ISO 3019-2 DIN 4x standard for IEC M-drive or foot bracket  
 ② Bracket pilot to SAE-C 4-bolt standard for NEMA M-drive or foot bracket

③ Standard ports SAE J518 code 61 flange. Optional tapped ports on same centerline include NPT or BSP (up to 4") or SAE O-Ring J1453 (up to 2").

# Dimensions

## Dimensions for Viking SG Series C-Flange Motor Mount (NEMA & IEC Footed Motors) Sizes - SG-04, SG-05, SGN-05, SG-07 & SGN-07

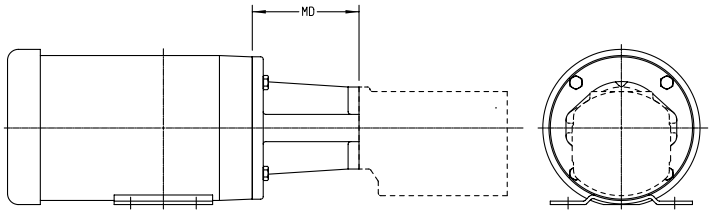
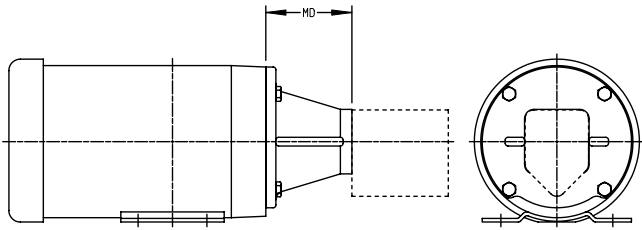

Series	Bracket	Motor Frame Size	MD	
			mm	in
SG-04 SG-05 SGN-05	NEMA	56C	95.3	3.75
		143TC	95.3	3.75
		145TC	95.3	3.75
		182TC	108.0	4.25
		184TC	108.0	4.25
	IEC	80 B35	94.7	3.73
90 B35		94.7	3.73	

Series	Bracket	Motor Frame Size	MD	
			mm	in
SG-07 SGN-07	NEMA	56C	124.0	4.88
		143TC	124.0	4.88
		145TC	124.0	4.88
		182TC	136.4	5.37
		184TC	136.4	5.37
		213TC	159.0	6.26
		215TC	159.0	6.26
		IEC	90 B35	130.3
	100 B14		133.6	5.26
	112 B14		133.6	5.26

## Dimensions for Viking SG Series C-Flange Motor Mount (NEMA & IEC Footed Motors) Sizes - SG-10 & SG-14

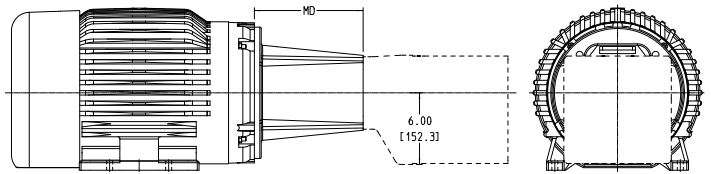
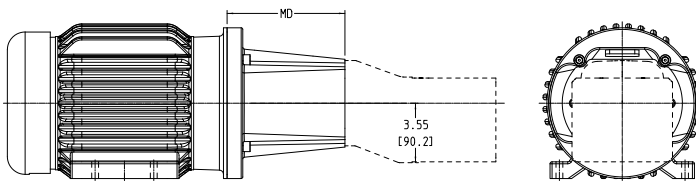

Series	Bracket	Motor Frame Size	MD	
			mm	in
SG-10	NEMA	56C ⊕	128.5	5.06
		143TC ⊕	128.5	5.06
		145TC ⊕	128.5	5.06
		182TC	144.5	5.69
		184TC	144.5	5.69
		213TC	168.4	6.63
		215TC	168.4	6.63
		254TC	178.8	7.04
		256TC	178.8	7.04
		284TC	206.0	8.11
	IEC	286TC	206.0	8.11
		90 B35	124.0	4.88
		100L B35	135.0	5.31
		112M B35	135.0	5.31
		132S/M B35	135.0	5.31
		160L B35	188.0	7.40
		180L B35	188.0	7.40
200M B35	204.0	8.03		

Series	Bracket	Motor Frame Size	MD	
			mm	in
SG-14	NEMA	182TC ⊕	193.8	7.63
		184TC ⊕	193.8	7.63
		213TC ⊕	193.8	7.63
		215TC ⊕	193.8	7.63
		254TC	193.8	7.63
		256TC	193.8	7.63
		284TC	231.6	9.12
		286TC	231.6	9.12
		324TC	231.6	9.13
		IEC	132 B35	168.0
	160 B35		204.0	8.03
	180 B35		204.0	8.03
	200 B35		204.0	8.03
	225 B35	233.9	9.21	

⊕ Pump extends below motor feet. Motor must be blocked up.

# Dimensions

## Dimensions for Viking SG Series Foot Bracket Mount

### Sizes - SG-04, SG-05 & SGN-05

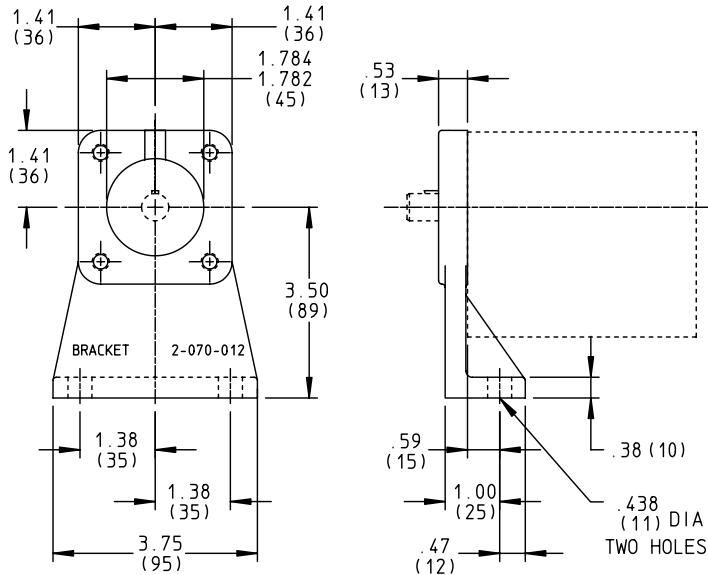

Note: Shaft height corresponds to Viking's "A" reducer or NEMA 56, 143T and 145T motors.

### Sizes - SG-07 & SGN-07

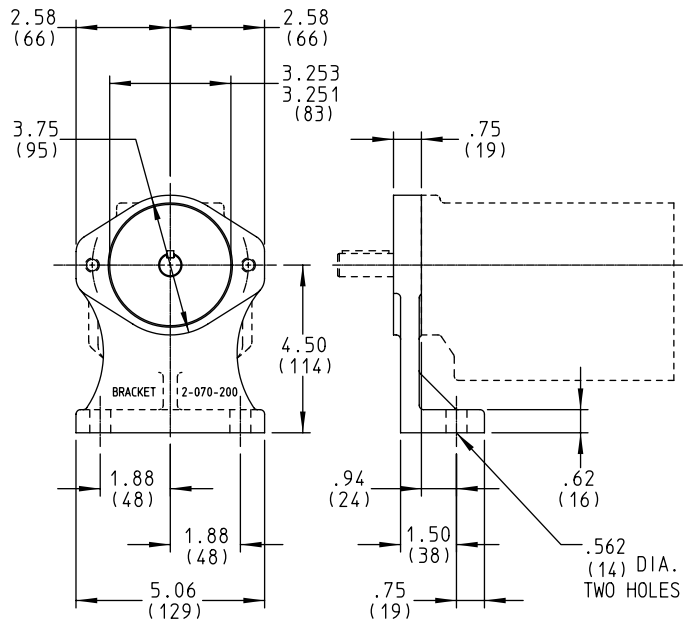

Note: Shaft height corresponds to NEMA 182T and 184T motors.

### Size - SG-10

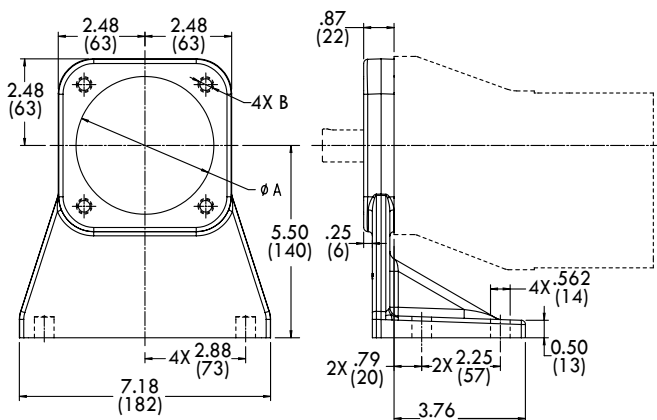

Note: Shaft height corresponds to Viking's "B" reducer.

### Size - SG-14

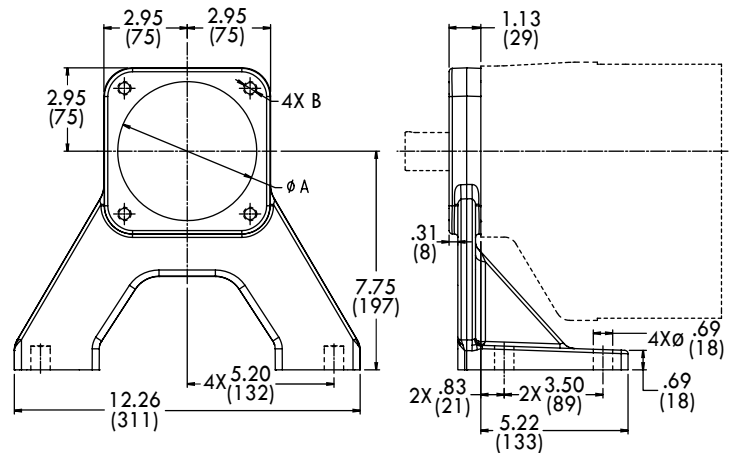

Note: Shaft height corresponds to Viking's "C" reducer.

For Use With		A	B
Pilot: SAE B 4-Bolt ("U" Bracket)	in	4.0	1/2 - 13
Pilot: ISO 100 mm 4-Bolt ("M" Bracket)	mm	100	M10 x 1.5

For Use With		A	B
Pilot: SAE C 4-Bolt ("U" Bracket)	in	5.0	1/2 - 13
Pilot: ISO 125 mm 4-Bolt ("M" Bracket)	mm	125	M12 x 1.75

# Dimensions



## Dimensions for Long-Coupled SG Series Sealless Viking Mag Drive® with Bearing Carrier

### MD-A\_B Drive - SG-804, SG-805 & SGN-805

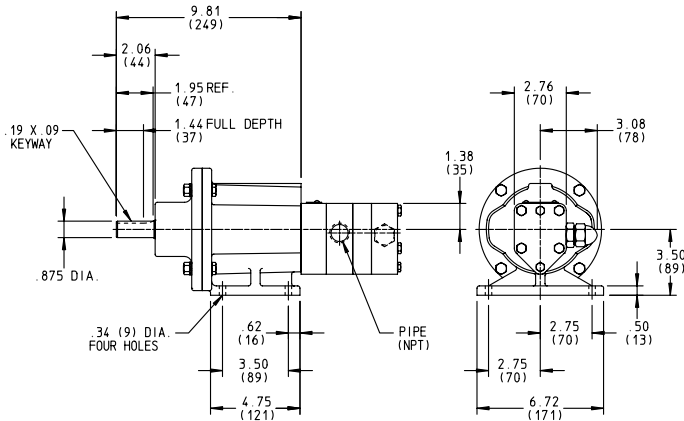

### MD-A\_B Drive - SG-807 & SGN-807

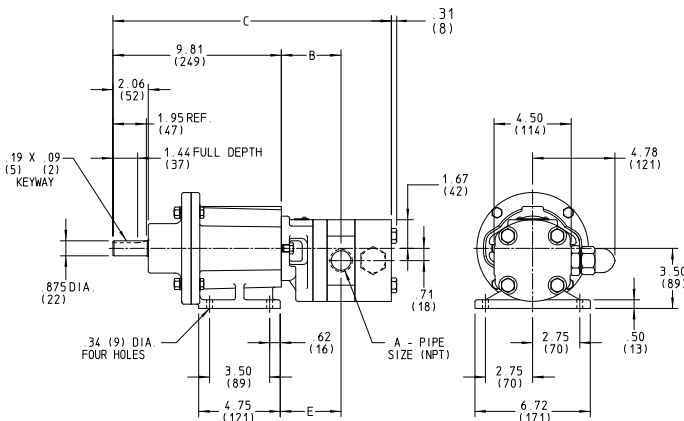

### MD-B\_B Drive - SG-807 & SGN-807

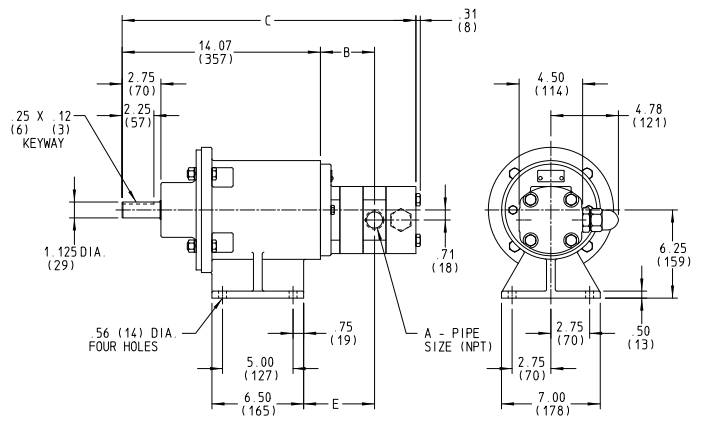

### MD2-B - SG-810 & MD2-C - SG-814

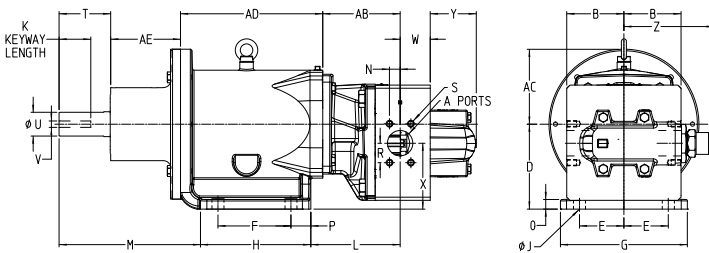

Dimensions in inches (mm)

PUMP	AB	W	N	R	S	A-PORTS	X	Y	L	Z	B
SG-81009	5.35 (135.9)	2.06 (52.3)	0.51 (13.0)	1.03 (26.2)	M10	1.00"			6.42 (163.1)		
SG-81013	5.91 (150.1)	2.13 (54.1)	1.90 (48.3)	0.70 (17.8)	M12	1.50"	4.50 (114.3)	3.63 (92.2)	6.98 (177.3)	6.63 (168.4)	3 (76.2)
SG-81026	6.13 (155.7)	2.88 (73.2)	1.53 (38.9)	0.84 (21.3)	M12	2.00"			7.20 (182.9)		
SG-81420	6.10 (154.9)	2.37 (60.2)	0.84 (21.3)	1.53 (38.9)	M12	2.00"			7.04 (178.8)		
SG-81436	6.80 (172.7)	3.27 (83.1)	1.21 (30.7)	2.09 (53.1)	M16	3.00"	5.19 (131.8)	3.63 (92.2)	7.74 (196.6)	7.11 (180.6)	4.5 (114.3)
SG-81456	7.19 (182.6)	4.88 (124.0)	1.53 (38.9)	2.56 (65.0)	M16	4.00"			8.13 (206.5)		

### Dimensions for "M" models for IEC Motors (mm)

Coupling	D	E	F	G	H	J	K	M	O	P	T	U	V	AD	AE
MD2-B (SG-810)	145	69.9	88.9	178	127.5	14.5	46	191	13.5	19	56.0	28	8	216	77.7
MD2-C (SG-814)	170	95.0	146.0	254	216.6	24.0	63	283	19.3	35.6	103.4	48	14	284	139.7

### Dimensions for "U" models for NEMA Motors (in.)

Coupling	D	E	F	G	H	J	K	M	O	P	T	U	V	AD	AE
MD2-B (SG-810)	5.50	2.75	4.88	7.00	6.41	0.56	2.12	7.60	0.53	0.78	2.72	1.125	0.25	9.30	2.87
MD2-C (SG-814)	6.69	3.75	5.75	10.00	8.53	0.945	2.50	11.14	0.76	1.40	4.07	1.875	0.50	11.20	5.50

# Dimensions

## Dimensions for SG Series Sealless Viking Mag Drive®

### Motor Mount - MD-A\_M Drive - SG-804, SG-805 & SGN-805

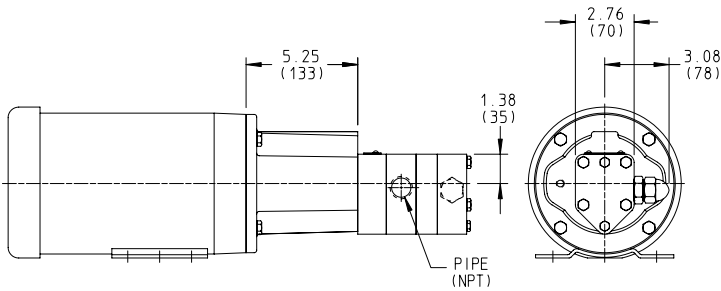

Series	NEMA Motor Frame Size
SG-804 SG-805 SGN-805	56C
	143TC
	145TC
	182TC
	184TC
	213TC*

\* Motor shaft must be modified to resemble 182TC-184TC shaft length, diameter and key. Requires footed motor.

### Motor Mount - MD-A\_M Drive - SG-807 & SGN-807

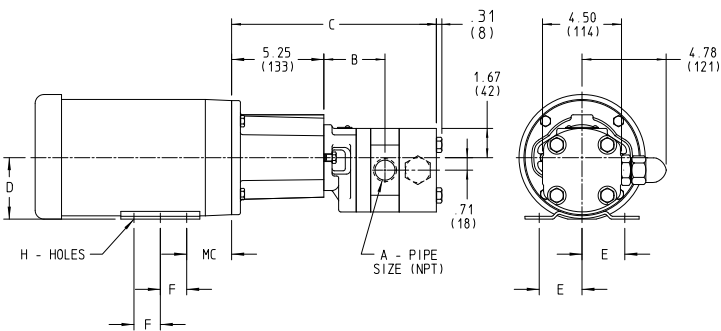

Series	NEMA Motor Frame Size
SG-807 SGN-807	56C
	143TC
	145TC
	182TC
	184TC
	213TC*

\* Motor shaft must be modified to resemble 182TC-184TC shaft length, diameter and key. Requires footed motor.

### Foot Bracket - MD-B\_M Drive - SG-807 & SGN-807

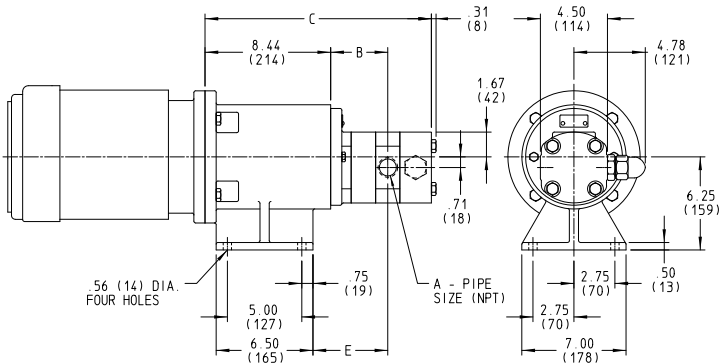

Series	NEMA Motor Frame Size
SG-807 SGN-807	182TC
	184TC
	213TC
	215TC
	254TC
	256TC

Requires unfooted motor.

### Foot Bracket - MD2-B\_M Drive - SG-810 & MD2-C\_M Drive - SG-814

Dimensions in inches (mm)

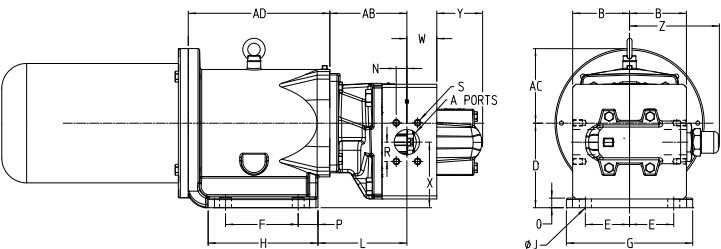

PUMP	AB	W	N	R	S	A-PORTS	X	Y	L	Z	B
SG-81009	5.35 (135.9)	2.06 (52.3)	0.51 (13.0)	1.03 (26.2)	M10	1.00"			6.42 (163.1)		
SG-81013	5.91 (150.1)	2.13 (54.1)	1.90 (48.3)	0.70 (17.8)	M12	1.50"	4.50 (114.3)	3.63 (92.2)	6.98 (177.3)	6.63 (168.4)	3 (76.2)
SG-81026	6.13 (155.7)	2.88 (73.2)	1.53 (38.9)	0.84 (21.3)	M12	2.00"			7.20 (182.9)		
SG-81420	6.10 (154.9)	2.37 (60.2)	0.84 (21.3)	1.53 (38.9)	M12	2.00"			7.04 (178.8)		
SG-81436	6.80 (172.7)	3.27 (83.1)	1.21 (30.7)	2.09 (53.1)	M16	3.00"	5.19 (131.8)	3.63 (92.2)	7.74 (196.6)	7.11 (180.6)	4.5 (114.3)
SG-81456	7.19 (182.6)	4.88 (124.0)	1.53 (38.9)	2.56 (65.0)	M16	4.00"			8.13 (206.5)		

### Dimensions for "M" models for IEC Motors (mm)

Coupling	Drive	D	E	F	G	H	J	O	P	AD
MD2-B (SG-810)	100/112	145	69.9	88.9	178	127.5	14.5	13.5	19	216
	132	170	69.9	108.0	178	146.3	14.5	13.5	19	236
MD2-C (SG-814)	132	170	95.0	146.0	254	216.6	24.0	19.3	35.6	284
	160/180	203	120.0	165.0	305	235.0	24.0	19.3	35	314

Requires unfooted motor.

### Dimensions for "U" models for NEMA Motors (in.)

Coupling	Drive	D	E	F	G	H	J	O	P	AD
MD2-B (SG-810)	182/184TC	5.50	2.75	4.25	7.00	5.78	0.56	0.53	0.78	8.92
	213/215TC	5.50	2.75	4.88	7.00	6.41	0.56	0.53	0.78	9.30
	254/256TC	6.50	2.75	5.50	7.00	7.03	0.56	0.53	0.78	9.92
MD2-C (SG-814)	213 thru 256TC	6.69	3.75	5.75	10.00	8.53	0.945	0.76	1.40	11.95
	284/286TC	6.69	3.75	5.75	10.00	8.53	0.945	0.76	1.40	12.49

# Related External Gear Products

## Double Pumps

With two pumping sections driven by the same motor, you can pump two liquids independently at different pressures, combine two liquids in the pump with a common discharge, or split a common suction line into two constant output flows. Product range includes 70 standard combinations of displacements in the SG-04, -05 & -07 sizes in cast iron, 49 combinations in ductile iron, with the same mounting options as SG single pumps. SG-10 and -14 double pumps may be developed upon request.



## Flow Dividers

Sealless flow dividers feature a common inlet with capacities up to 16 M<sup>3</sup>/Hr (70 GPM), from which flow is divided into two, three or four separate discharge streams, either equally or in specified ratios. Unlike manifolds where liquid flows to the lowest pressure zone, flow dividers are independent of backpressure, ensuring consistent flow to each port.

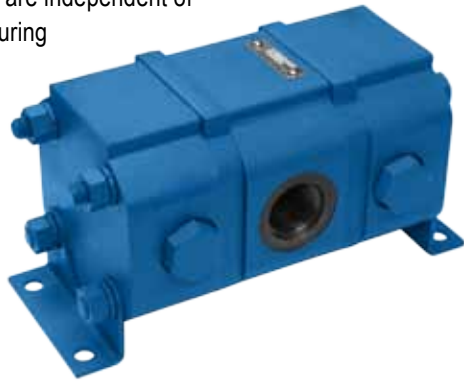

## Hydraulic Motors

Viking GP pumps may also be operated as motors, using a hydraulic circuit to power fans, pumps and other rotary equipment.



## Custom Pumps

Viking offers OEM customers custom-engineered pumps for a variety of applications, from a triple pump for heavy duty truck scavenge, lube and hydraulics (shown), to high speed double pumps greater than 114 M<sup>3</sup>/Hr (500 GPM) for large engine fuel and lubrication. Contact Viking OEM sales for design assistance.



## Fluid Power Pumps

Viking GP pumps are designed to power hydraulic circuits in fluid power. With pressures to 170 Bar (2,500 PSI), they are simple, reliable pumps for actuating cylinders and other hydraulic applications.



## Power Transfer Units

PTUs are Viking internal gear pumps and external gear pumps with integral hydraulic motors, enabling anyone to turn a hydraulic circuit into a transfer pumping system. These are low-cost means of pumping liquids in hazard areas where explosion-proof motors would otherwise be required, by locating the drive motor outside of the hazard area.





A Unit of IDEX Corporation

# Leader in Positive Displacement Pumping Solutions.

## Innovation and Experience

Viking Pump has been a pump industry leader and innovator since its founding in 1911. We continue to build on our ever growing experience delivering innovative new pumping solutions, including custom designs, to thousands of customers who use Viking® pumps in some of the world's toughest applications.

## Broad Performance Range

**Capacity:**

0.5 to 360 M<sup>3</sup>/Hr (0.1 to 1,600 GPM)

**Pressure:**

0 to 170 Bar (0 to 2,500 PSI)

**Temperature:**

-84°C to 370°C (-120°F to 700°F)

**Viscosity:**

0.5 to 1,000,000 cSt (28 to 4,500,000 SSU)

## Ultimate in Sealing Solutions

Viking's offering of packing, component mechanical seals, cartridge seals and sealless Mag Drive technology provides the best choices for sealing flexibility needed to provide your application a customized sealing solution every time - saving you money, time and unplanned downtime.

## Material Options Matched to Application

Viking's dedicated iron and alloys foundries provide pump construction materials from cast iron to Alloy C. Application-specific materials of construction extend a pump's life significantly, while reducing maintenance and unplanned downtime, enabling increased production and a better bottom line.

## Liquid Integrity Protection

Viking has developed multiple positive displacement pump principles to protect shear-sensitive liquids, and low-shear options to prevent damage to fibers, polymers and solids. Full-jacketing options provide precise temperature control throughout the pump. The Viking Mag Drive® and other seal options prevent fluid contact with air, assuring liquid integrity.

## Local Applications and Engineering Support

Over 245 Authorized Viking Pump Distributors in 68 countries provide local application support and service. They are backed by Viking Application Engineers and Viking Region Managers strategically located around the world.

## Quality Manufacturing

Viking uses ISO9001-2008, Six-Sigma, and Lean/Kaizen in its worldwide manufacturing and assembly processes to remove waste, reduce development costs, and deliver superior products. Dedicated Viking foundries and manufacturing facilities utilize state-of-the-art CNC equipment to assure unmatched quality is built into every pump.

## Custom Designed Solutions

Viking has provided custom designed pumps to end-users and OEMs since its first pump in 1911, when Viking invented the gear-within-a-gear pumping principle to remove water from a rock quarry. Today, enabled by Viking's engineering staff, extensive applications experience and in-house foundries, more than 20% of Viking's sales are new designs or pump designs derived from one of our 40,000 active configurations. Whether you are an end-user or an OEM, Viking can provide custom designed pumping solutions to meet your specific needs.



**For more information, contact your local Authorized Viking Pump Distributor or contact Viking at:**

### VIKING PUMP, INC.

A Unit of IDEX Corporation  
406 State Street  
Cedar Falls, Iowa 50613-0008 U.S.A.  
Telephone: (319) 266-1741  
Fax: (319) 273-8157  
E-mail: [info.viking@idexcorp.com](mailto:info.viking@idexcorp.com)  
Web site: [www.vikingpump.com](http://www.vikingpump.com)

#### CANADA

**Windsor, Ontario**  
Phone: (519) 256-5438  
Fax: (519) 256-5070  
[www.vikingpumpcanada.com](http://www.vikingpumpcanada.com)

#### EUROPE

**Shannon, Ireland**  
Phone: +353 (61) 471933  
Fax: +353 (61) 475046  
[www.vikingpumpeurope.co.uk](http://www.vikingpumpeurope.co.uk)

#### LATIN AMERICA

**Mexico D.F., C.P.**  
Phone: +52 (55) 5255-1357  
Fax: +52 (55) 5255-1356

**Brazil - Sao Paulo**  
Phone: +55 (19) 3871-3500  
Fax: +55 (19) 3871-6400

#### ASIA-PACIFIC GROUP

**Singapore**  
Phone: +65-6763-6633  
Fax: +65-6764-4020  
[www.idexfmt-asia.com](http://www.idexfmt-asia.com)

#### China - Shanghai

Phone: +86-21-5241-5599  
Fax: +86-21-5241-8339  
[www.idexfmt-asia.com](http://www.idexfmt-asia.com)

#### China - Beijing

Phone: +86-10-6566-9090  
Fax: +86-10-6567-5152  
[www.idexfmt-asia.com](http://www.idexfmt-asia.com)

#### China - Guangzhou

Phone: +86-20-3886-6156  
Fax: +86-20-3886-2776  
[www.idexfmt-asia.com](http://www.idexfmt-asia.com)

#### India - Mumbai

Phone: +91-22-66976634  
Fax: +91-9820334270  
[www.idexfmt-asia.com](http://www.idexfmt-asia.com)

#### ASIA-PACIFIC GROUP

**China - Chengdu**  
Phone: +86-28-86767458  
Fax: +86-28-86767468  
[www.idexfmt-asia.com](http://www.idexfmt-asia.com)

#### China - Suzhou

Phone: +86-512-62833000  
Fax: +86-512-62833010  
[www.idexfmt-asia.com](http://www.idexfmt-asia.com)

#### Korea - Seoul

Phone: +82-2-501-3302  
Fax: +82-2-556-0788  
[www.idexfmt-asia.com](http://www.idexfmt-asia.com)

#### Australia & New Zealand

Phone: +61 2 4577 4534  
Fax: +61 2 4577 5987  
[www.idexfmt-asia.com](http://www.idexfmt-asia.com)

#### MIDDLE EAST

IDEX Middle East FZE  
**Dubai, UAE**  
Phone: +971-4-299-1095/1097  
Fax: +971-4-299-1069  
[www.idexfmt-asia.com](http://www.idexfmt-asia.com)