

**VIKING
PUMP**
A Unit of IDEX Corporation

Viking® Mag Drive Pumps

*Dimensionally Interchangeable,
Sealless Mag Drive Pumps for Crucial
Liquid Containment Applications*



**UNIVERSAL
IMAG DRIVE**

The Universal Mag Drive series can reduce maintenance and environmental costs by eliminating the pump shaft seal saving you more than 50% of the total pump, parts and downtime cost in one year.



3 Year Limited Warranty

Sizes in Series: 9

Capacity to 114 M³/Hr (500 GPM)

Pressure to 14 Bar (200 PSI)

Viscosity 1 to 55,000 cSt (28 to 250,000 SSU)

Temperature -84°C to +260°C (-120°F to +500°F)

motralec

4 rue Lavoisier . ZA Lavoisier . 95223 HERBLAY CEDEX

Tel. : 01.39.97.65.10 / Fax. : 01.39.97.68.48

Demande de prix / e-mail : service-commercial@motralec.com

www.motralec.com

**IDEX
CORPORATION**

Viking® Advantages

The Universal Mag Drive series can reduce maintenance and environmental costs through eliminating the pump shaft seal.

Simply by eliminating the pump shaft seal, the Universal Mag Drive can save you more than 50% of the total pump, parts and downtime cost in one year. Assuming the cost of:

- Spare mechanical seal
- Mechanical seal accessories
- Two seal replacements and repairs yearly
- Unplanned downtime
- Lost production
- Lost process revenue at \$1,000 per hour
- Potential EPA fines for leaks and/or spills



Performance

- No packing or mechanical seals means no seal failure or replacement
- Easily handles both high and low viscosity fluids
- Reduce material loss, contamination and general housekeeping
- Simple design, easy to maintain
- Proven reliability, 20+ years of experience

Technology

- Dimensionally interchangeable with Viking's Universal Seal and Heavy-Duty Bracketed pumps
- Proven sealless design
- Simple solution for upgrading existing pumps
- Short-term, dry-run capabilities for easy line clearing or emptying tanks without damaging the pump
- Viking developed the first commercially available internal gear mag drive pump

Universal Mag Drive Value vs. Mechanical Seal Pumps

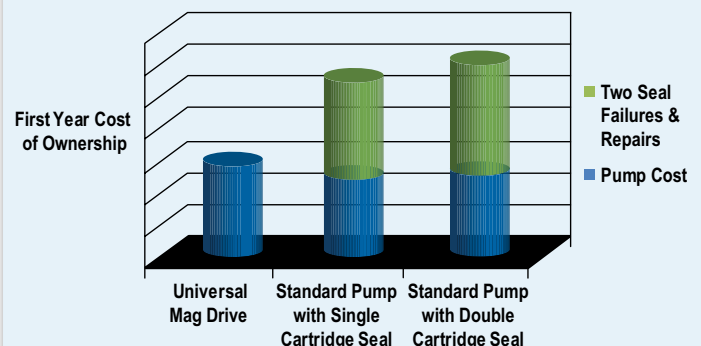

A customized scenario needs to be adapted to fit each customer's application and operating parameters. The accuracy of the calculated savings depends upon the accuracy of customer supplied data. Note that pump configuration and materials used for pumps varies with application. In addition, pumps should only be used for the particular application with the particular liquids specified when pumps are ordered.

Productivity

- Highest level of liquid containment available
- Eliminates downtime due to seal replacement
- Local inventory and support worldwide
- Bi-directional pump design for enhanced application flexibility
- Lower life cycle cost
- 3 year limited warranty

Available Options

- Multiple port sizes, types and ratings available, including threaded, raised, and flat-face flanged
- Jacketing options available for critical areas of pumps, including the casing, head and relief valve
- Materials of construction: steel, stainless steel, and cast iron
- Special construction options for bushings, shafts, pins and clearances available
- Protective device options include: power load monitor, temperature monitor, and low flow detector
- Other options include: casing and canister drains and gauge ports

Hard-to-Seal Liquids



Shaft seal leakage is the number one cause of pump downtime and maintenance. Shaft seals wear faster when liquid, air and heat combine at the seal to cause chemical reactions, like:

- **Crystallization** (e.g. isocyanates)
Abrasive crystals cause premature wear.
- **Sticking** (e.g. adhesives, epoxy resins, paints) Seal faces bond when pump stops and fails at startup.
- **Varnishing** (e.g. petroleum products)
Layer builds up on seal faces causing separation.

Typical Applications:

- Isocyanates
- Sodium Hydroxide
- Adhesives
- Epoxy Resins

Hazardous & Reactive Liquids



Shaft seals can allow liquids and vapors out, causing hazardous exposure and allowing air in, causing unwanted chemical reactions. Traditional sealed pumps, including those that require flushing, quenching and barrier fluids, are subject to the same failures as single seals, with the additional cost and maintenance headaches of the associated equipment (pumps, pressure vessel, tubing/piping, filters, etc.). When you consider the alternatives, the dimensionally interchangeable Universal Mag Drive Series provides the highest level of containment available.

Typical Applications:

- Volatile Organic Chemicals
- Hazardous Chemicals
- LPG and Ammonia
- Reactive Chemicals

24/7 Operations



Unplanned downtime to fix a leaky seal is unacceptable in facilities with continuous processes, such as refineries, chemical plants and paper mills. Even when pumping "safe" liquids, seals are subject to mechanical problems like loss of compression, misalignment of pump and driver, improper seal installation, shaft deflection causing off-center faces, suction lift (vacuum) causing face separation and many others. If you can't afford pump downtime, the Universal Mag Drive Series offers exceptional up-time reliability through its robust, sealless design.

Typical Applications:

- Refineries
- Chemical and Polymer Plants
- Paper Mills
- Pipelines

Dimensionally Interchangeable Design

The Universal Mag Drive series provides a dimensionally interchangeable footprint with the Viking's Universal Seal, Heavy-Duty

Bracketed and other similar manufacturer's pumps. This allows for an easy upgrade from packing or mechanical seals to sealless

Mag Drive technology, providing the highest level of liquid containment available in the marketplace today.

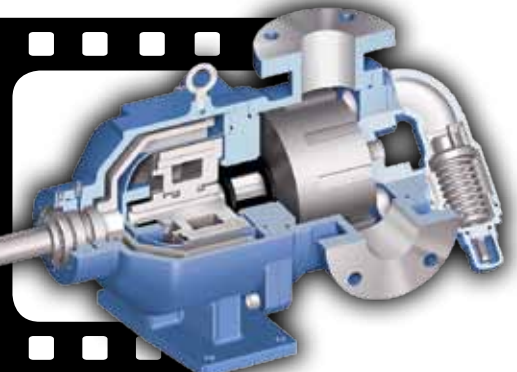
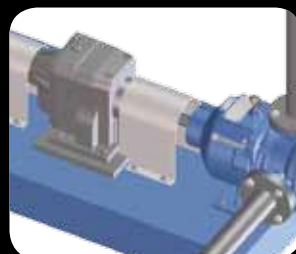
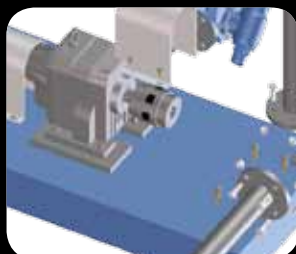
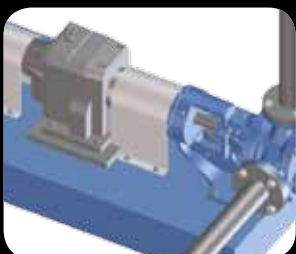

Viking® Benefits

ADVANCED DURABILITY

■ Proven Design

Pump has only two moving parts and is proven in thousands of tough applications around the world. **Simple design minimizes service requirements while providing unmatched durability and reliability.**

■ Heavy Duty Bearings and Bushings

Proven, rugged pump design equipped with heavy-duty bearings and bushings. **Provides enhanced shaft support extending pump and in-canister bushing life.**

■ Innovative Magnet Design

Inner magnet is encapsulated in a laser welded stainless steel canister. **One-piece design eliminates O-ring seal, extends pump life and eliminates seal maintenance.**

■ Dimensionally Interchangeable

Proven, dimensionally interchangeable design for Viking's Universal Seal and Heavy-Duty Bracketed pumps as well as competitive pumps that duplicate Viking's foot print. **Provides simple solution for upgrading existing pumps, utilizing existing reducer, motor, coupling, guard, wiring and base.**

■ Multiple Port Configurations

Multiple port sizes, types and ratings are available including threaded, raised and flat face flanged (125#, 150#, 250# & 300#). **Provides an easy solution to match customer requirements for quick, easy installation.**

■ Rotatable Casing

Universal Mag Drive pumps are equipped with casings that can be positioned to meet common piping configurations, including 90° and opposite porting. **Shortens and simplifies installation with no special tools required for quick installation.**

■ No Special Tools Required

Jack bolts for coupling disassembly are standard with the pump. **Simplifies maintenance and reduces planned downtime.**

■ Drive Options

Multiple drive options are available including reducer, and variable speed drive. **Drive configurations provide easy solutions to match customer requirements for quick, easy installation.**

■ 3-Year Limited Warranty

Best in class warranty that covers workmanship and materials. **Warranty provides greater peace of mind.**

LL8123A Size
Pump Shown

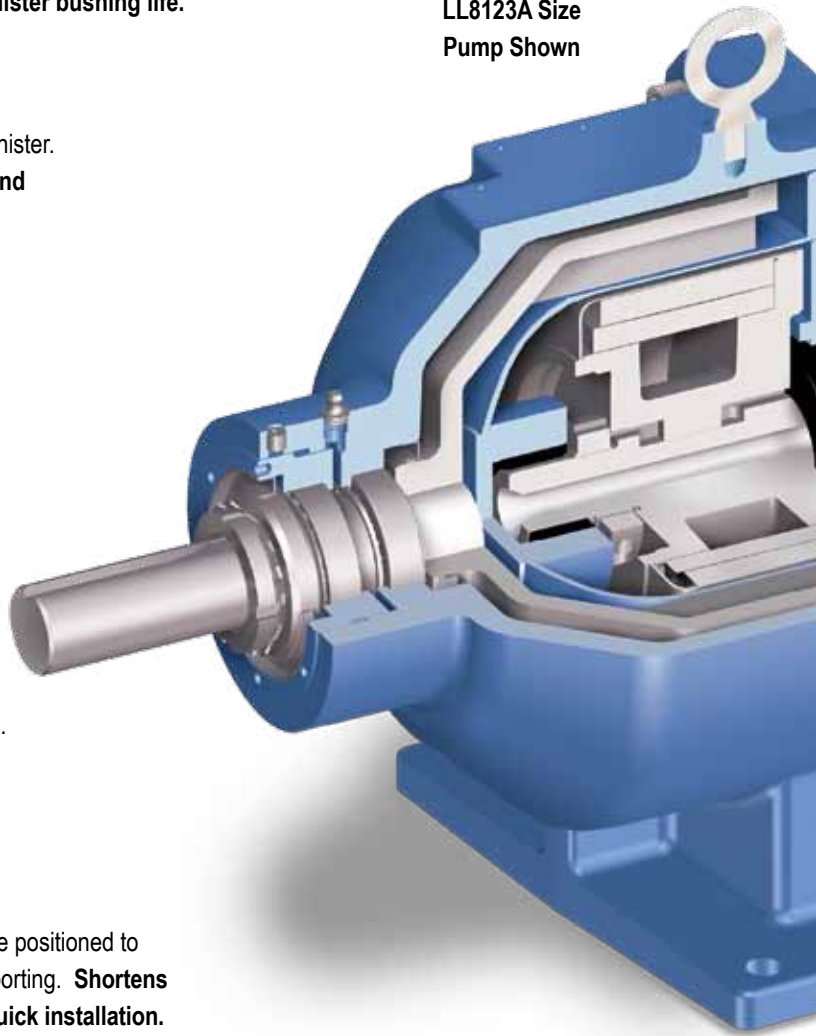

■ Lifting Lug Included

Allows for easier pump handling when installing, removing or disassembling pump. **Simplifies installation.**

EASY INSTALLATION

■ Externally Adjustable Relief Valve

Relief valve can be adjusted without disassembly when process conditions change. **Provides maximum process up-time.**

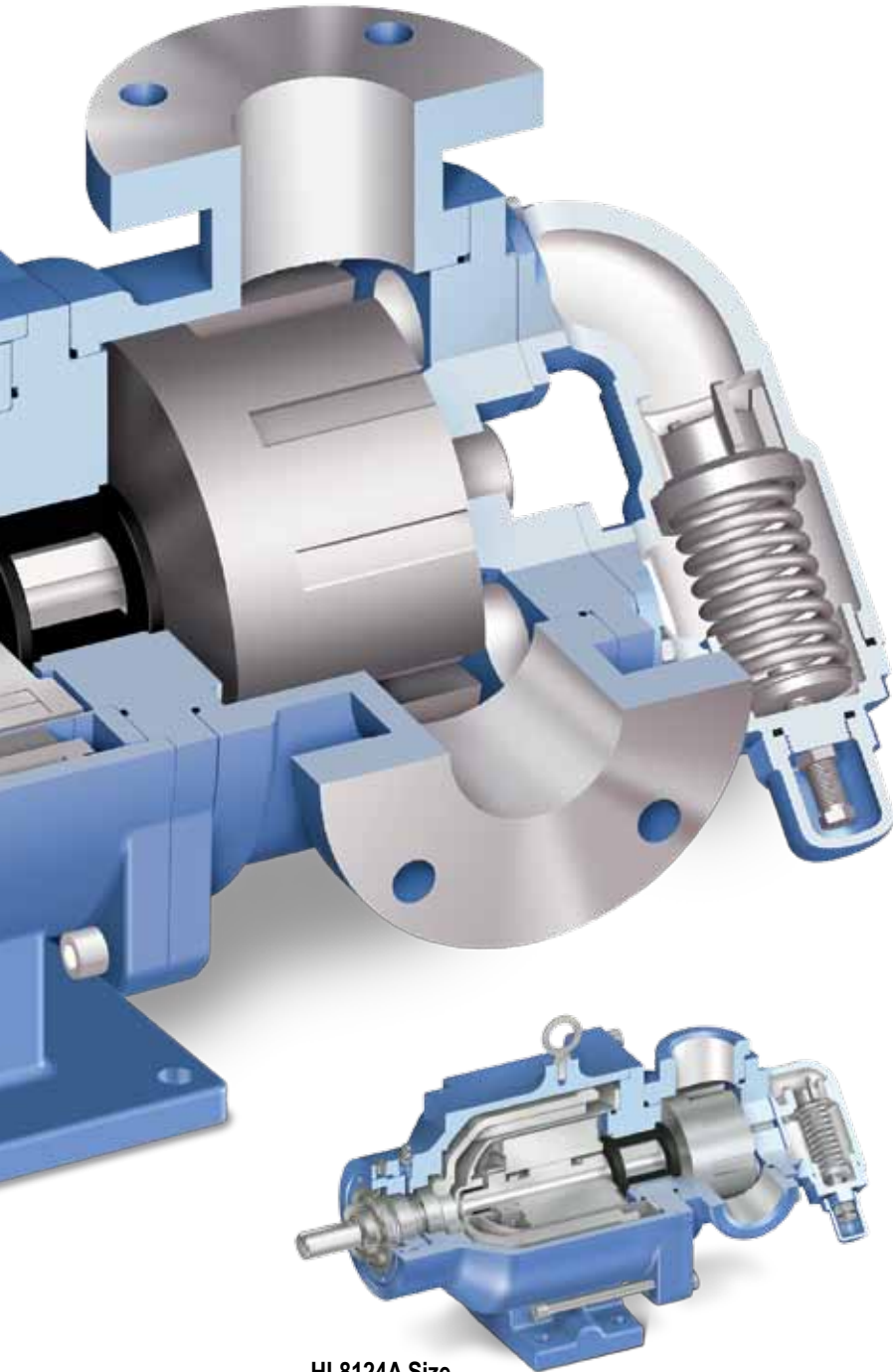

HL8124A Size
Pump Shown

■ Relief Valve, Standard

Pumps come with an adjustable internal pressure relief valve on standard design. Jacketed pressure relief valves are available. **Protects pump from over-pressure.**

■ Multiple Material Options

Wide array of pump construction materials available for internal and external components allow broad chemical and temperature compatibility on lubricating and non-lubricating liquids to match your application need. **Custom configured pumps lengthen the life of the pump for lower total cost of ownership.**

■ Short-Term Run-Dry Capability

Short-term run-dry capability is possible due to state of the art design and magnet technology. **Protects the pump during priming and accidental empty-tank situations.**

■ Bi-directional Pump Design

Bi-directional pumping design eliminates cost of a second pump and the piping needed for loading or unloading or line stripping. **Provides application flexibility and reduces system costs.**

■ Adjustable End Clearance

Allows the pump to be adjusted for different viscosities and temperatures if process changes, increasing productivity. **Maximizes pump efficiency, extending life.**

■ Dual Thrust Control Washers

Positive control of rotor position for more accurate flow, also reduces pump wear. **Provides lower life cycle costs and improves process control capability.**

■ Optimized Efficiency

Proven, optimized gear and pump geometry maximizes overall efficiency. **Reduces product operating cost, providing a lower total cost of ownership.**

■ Higher Pressure Capabilities

Thrust control, enhanced shaft support and a wide selection of materials permits higher pressure capabilities. **Permits single pump standardization for multiple liquids and applications.**

Materials of Construction

Universal Mag Drive Series Construction

Component		Cast Iron Series 8124A	Steel Externals Series 8123A	Stainless Steel Series 8127A
Casing		Cast Iron ASTM A48, Class 35B	Steel ASTM A216, Grade WCB	Stainless Steel ASTM A 743, Grade CF8M
Head		Cast Iron ASTM A48, Class 35B	Steel ASTM A216, Grade WCB	Stainless Steel ASTM A 743, Grade CF8M Case Hardened
Bracket		Cast Iron ASTM A48, Class 35B	Cast Iron ASTM A48, Class 35B	Cast Iron ASTM A48, Class 35B
Idler	Standard	② Cast Iron ASTM A48 Class 35B	② Cast Iron ASTM A48 Class 35B	Stainless Steel ASTM A 743, Grade CF8M Case Hardened
	Optional Material	Consult Factory	Consult Factory	Non-Galling Stainless and PPS Composite
Rotor	Standard	① Cast Iron ASTM A48, Class 35B	① Cast Iron ASTM A48, Class 35B	Stainless Steel ASTM A 743, Grade CF8M Case Hardened
	Steel Fitted	Steel ASTM A148, Grade 80-50	Steel ASTM A148, Grade 80-50	NA
Rotor Shaft	Standard	Steel ASTM A108, Grade 1045	Steel ASTM A108, Grade 1045	Hard Coated Stainless Steel ASTM A276 Type 316 Hard Coated
	Optional Material	Hardened Steel ASTM A108, Grade 1045	Hardened Steel ASTM A108, Grade 1045	NA
Idler Pin		Hardened Steel ASTM A108, Grade 1045	Hardened Steel ASTM A108, Grade 1045	Hard Coated Stainless Steel ASTM A276 Type 316 Hard Coated
Idler Bushing	Standard	Carbon Graphite	Carbon Graphite	Carbon Graphite
	Optional Material	Hardened Cast Iron, Silicon Carbide	Hardened Cast Iron, Silicon Carbide	Silicon Carbide
Internal Pressure Relief Valve		Cast Iron ASTM A48, Class 35B	Steel ASTM A216, Grade WCB	Stainless Steel ASTM A 743, Grade CF8M
Canister		316L Stainless Steel	316L Stainless Steel	316L Stainless Steel
Canister Bushing	Standard	Carbon Graphite	Carbon Graphite	Carbon Graphite
	Optional Material	Hardened Cast Iron, Siliconized Graphite	Hardened Cast Iron, Siliconized Graphite	Siliconized Graphite
Thrust Washers	Standard	④ Hardened Cast Iron	④ Hardened Cast Iron	④ Silicon Carbide
	Optional Material	Silicon Carbide	Silicon Carbide	NA
Coupling Magnets	Standard	Neodymium Iron Boron	Neodymium Iron Boron	Neodymium Iron Boron
	Optional Material	Samarium Cobalt	Samarium Cobalt	Samarium Cobalt
O-rings	Standard	Buna-N	Buna-N	PTFE (Derivative) Encapsulated
	Optional Materials	Viton®, PTFE (Derivative) Encapsulated, Kalrez®	Viton®, PTFE (Derivative) Encapsulated, Kalrez®	Viton®, Kalrez®
Adapter Plate		Cast Iron ASTM A48, Class 35B	Steel ASTM A216, Grade WCB	Stainless Steel ASTM A743, Grade CF8M
Adapter Bushing	Standard	Carbon Graphite	Carbon Graphite	Carbon Graphite
	Optional Materials	Hardened Cast Iron, Silicon Carbide	Hardened Cast Iron, Silicon Carbide	Silicon Carbide

① KK, LS and QS sizes have a ductile iron rotor, ASTM A536 Grade 60-40-18.

② H and HL sizes have powdered metal idler, MPIF std 35 FC-0208-50.

③ Steel fitted Q and QS sizes have steel idler.

④ Q and QS contains two sets of thrust washers, one set is carbon graphite as standard.

Consult factory for more options.

Kalrez® is a registered trademark of DuPont Performance Elastomers.

Viton® is a registered trademark of DuPont Performance Elastomers.

Universal Mag Drive Series Specifications

Pump Model	⑥ Standard Port Size		⑦ Capacity at Maximum Rated Speed			Maximum Hydrostatic Pressure		① Maximum Discharge Pressure		② Maximum Recommended Temperature		Approximate Shipping Weight	
	mm	in.	M ³ /Hr.	GPM	RPM	BAR	PSI	BAR	PSI	Deg. C	Deg. F	Kg.	Lb.
H8124A	40 ③	1.5 ③	3.4	15	1750	28	400	14	200	107	225	27	60
H8123A	40 ⑤	1.5 ⑤						10	150			32	70
H8127A								14	200			27	60
HL8124A	40 ③	1.5 ③	6.8	30	1750	28	400	14	200	107	225	27	60
HL8123A	40 ⑤	1.5 ⑤						10	150			32	70
HL8127A								14	200			27	60
K8124A	50 ③	2 ③	18	80	780	28	400	14	200	107	225	88	195
K8123A	50 ⑤	2 ⑤						10	150			93	205
K8127A								14	200			88	195
KK8124A	50 ③	2 ③	23	100	780	28	400	14	200	107	225	88	195
KK8123A	50 ⑤	2 ⑤						10	150			93	205
KK8127A								14	200			88	195
L8124A	50 ③	2 ③	30	135	640	28	400	14	200	107	225	127	280
LQ8124A	65 ④	2.5 ④	30	135	640	28	400	14	200	107	225	132	290
LQ8123A	65 ⑤	2.5 ⑤						10	150			134	295
LQ8127A								14	200			127	280
LL8124A	75 ④	3 ④	39	170	640	28	400	14	200	107	225	93	205
LL8123A	75 ⑤	3 ⑤						10	150			143	315
LL8127A								14	200			93	205
LS8124A	75 ④	3 ④	45	200	640	28	400	14	200	107	225	154	340
LS8123A	75 ⑤	3 ⑤						10	125			159	350
LS8127A								14	200			154	340
Q8124A	100	4	68	300	520	28	400	14	200	107	225	320	705
Q8123A								10	125			331	730
Q8127A								14	200			320	705
QS8124A	150	6	114	500	520	28	400	14	200	107	225	352	775
QS8123A								9	125			365	805
QS8127A								14	200			352	775

① For maximum recommended discharge pressures, see performance curves.

② Extra clearances are required above 225° F. Higher temperatures can be handled with special construction, consult factory.

③ Ports are tapped for standard (NPT) pipe.

④ Ports are suitable for use with ANSI Class 125 cast iron companion flanges or flanged fittings.

⑤ Ports are suitable for ANSI Class 150 steel or stainless steel companion flanges or flanged fittings.

⑥ Consult factory for other port size or type options.

⑦ Nominal capacity on medium viscosity liquids with clockwise rotation. There is a slight reduction in capacity at viscosities less than 100 SSU with counter-clockwise rotation.

Model Number Key

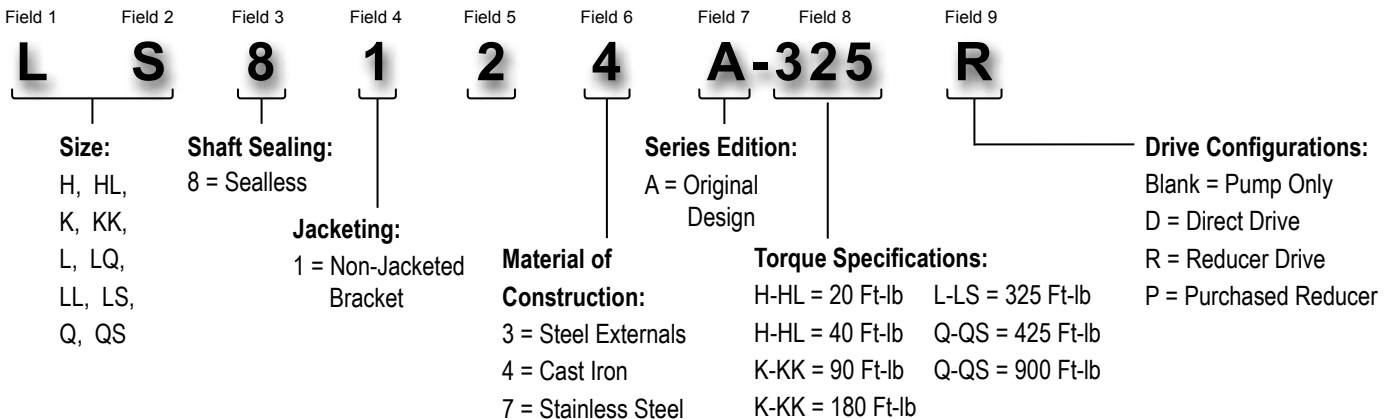

Dimensions

Dimensions for H through LS Sizes - All Materials of Construction

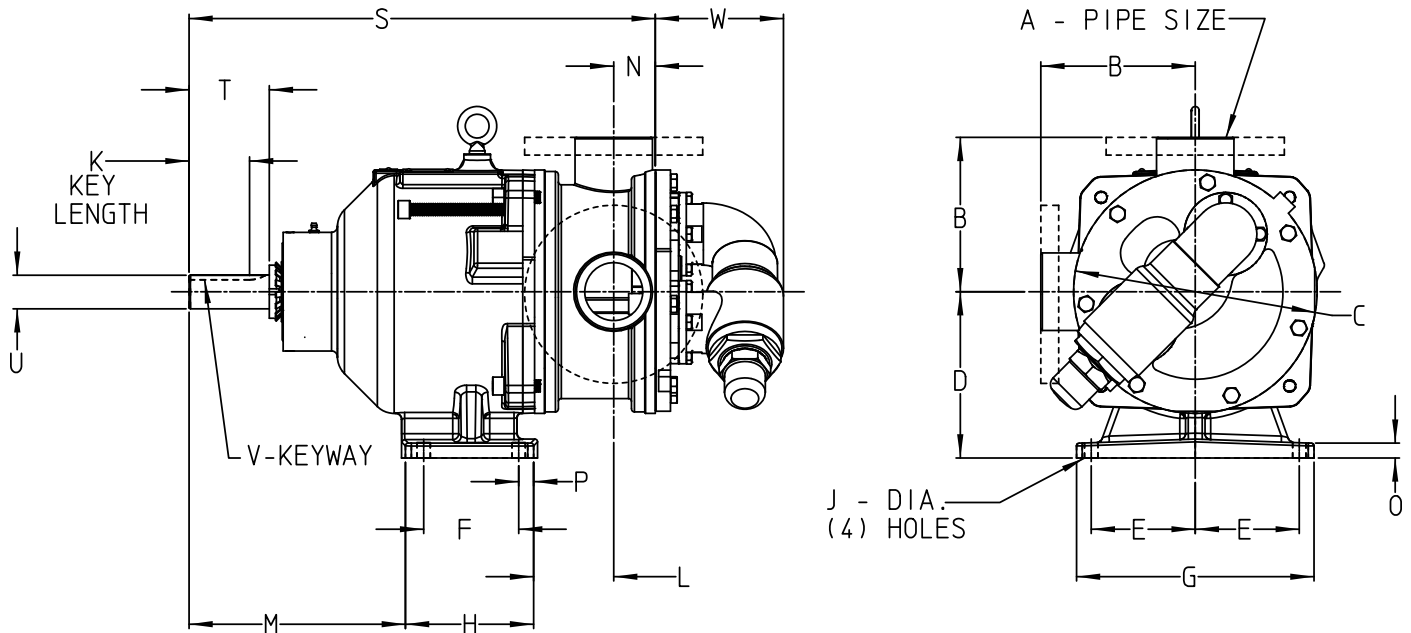

Model		A	B	C	D	E	F	G	H	J	K	L	M	N	O	P	S	T	④ U	V	W
H8124A	mm	38	76	121	89	70	57	171	89	12	25	86	132	30	14	16	337	41	0.75	.19 x .09	73
HL8124A	in.	1.5 ①	3.00	4.75	3.50	2.75	2.25	6.75	3.50	0.47	0.99	3.38	5.19	1.19	0.56	0.62	13.26	1.62			
H8123A	mm	38	102	121	89	70	57	171	89	12	25	86	132	30	14	16	337	41	0.75	.19 x .09	73
H8127A	mm	38	102	121	89	70	57	171	89	12	25	86	132	30	14	16	337	41			
HL8123A HL8127A	in.	1.5 ③	4.00	4.75	3.50	2.75	2.25	6.75	3.50	0.47	0.99	3.38	5.19	1.19	0.56	0.62	13.26	1.62			
K8124A	mm	50	130	203	140	102	70	235	100	14	31	77	239	44	16	15	460	57	1.125	.25 x .12	133
KK8124A	in.	2 ①	5.12	8.00	5.50	4.00	2.75	9.25	3.95	.56	1.42	3.03	9.39	1.75	.62	.60	18.12	2.25			
K8123A	mm	50	133	203	140	102	70	235	100	14	31	77	239	44	16	15	460	57	1.125	.25 x .12	133
K8127A	mm	50	133	203	140	102	70	235	100	14	31	77	239	44	16	15	460	57			
KK8123A KK8127A	in.	2 ③	5.25	8.00	5.50	4.00	2.75	9.25	3.95	.56	1.42	3.03	9.39	1.75	.62	.60	18.12	2.25			
L8124A	mm	50	165	260	178	112	102	254	137	14	65	86	231	44	16	16	499	86	1.438	.38 x .19	137
L8124A	in.	2 ①	6.50	10.25	7.00	4.38	4.00	10.00	5.40	.56	2.55	3.37	9.11	1.75	.62	.63	19.63	3.38			
LQ8124A	mm	65	183	260	178	112	102	254	137	14	65	86	231	44	16	16	499	86	1.438	.38 x .19	137
LQ8123A	mm	65	183	260	178	112	102	254	137	14	65	86	231	44	16	16	499	86			
LQ8127A	in.	2.5 ②③	7.19	10.25	7.00	4.38	4.00	10.00	5.40	.56	2.55	3.37	9.11	1.75	.62	.63	19.63	3.38			
LL8124A	mm	75	183	260	178	112	102	254	137	14	65	86	231	57	16	16	511	86	1.438	.38 x .19	137
LL8123A	mm	75	183	260	178	112	102	254	137	14	65	86	231	57	16	16	511	86			
LL8127A	in.	3 ②③	7.19	10.25	7.00	4.38	4.00	10.00	5.40	.56	2.55	3.37	9.11	2.25	.62	.63	20.13	3.38			
LS8124A	mm	75	183	260	178	112	102	254	137	14	65	120	231	62	16	16	551	86	1.438	.38 x .19	137
LS8123A	mm	75	183	260	178	112	102	254	137	14	65	120	231	62	16	16	551	86			
LS8127A	in.	3 ②③	7.19	10.25	7.00	4.38	4.00	10.00	5.40	.56	2.55	4.74	9.11	2.44	.62	.63	21.69	3.38			

① Series 8124A ports are tapped for standard (NPT) pipe.

② Series 8124A, sizes LQ, LL and LS ports are suitable for use with 125# ANSI cast iron flanges or flanged fittings.

③ Series 8123A and 8127A ports are suitable for 150# ANSI steel or stainless steel companion flanges or flanged fittings.

④ When replacing on existing units, sizes L, LL and LQ may require a different size coupling half.

Dimensions for Q Size - All Materials of Construction

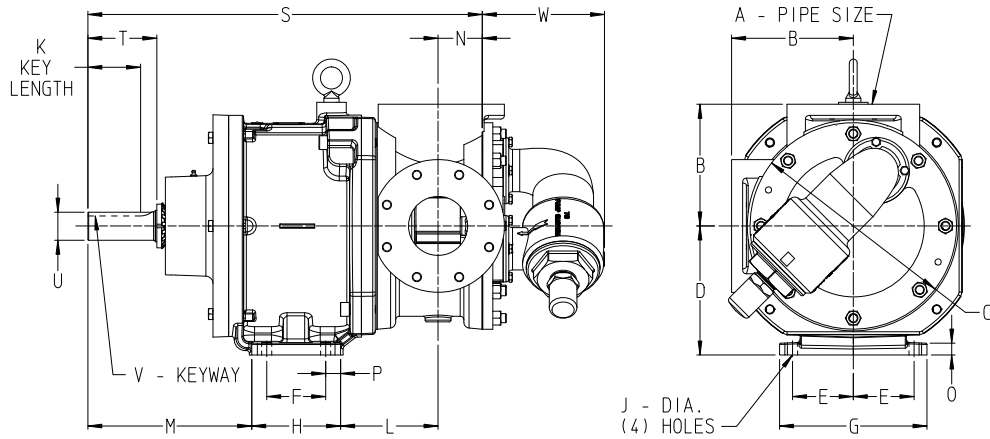

Model	A (in)	B	C	D	E	F	G	H	J	K	L	M	N	O	P	S	T	U ^④	V	W	
Q8124A	②③ 4	in	8.25	14.00	8.75	4.12	4.00	10.00	6.00	0.69	3.58	6.62	11.13	3.00	0.80	1.00	26.75	4.68	1.94	.50 x .25	8.29
Q8123A		mm	210	356	222	105	102	254	152	18	91	168	283	76	20	25	679	119	49		211
Q8127A																					

Dimensions for QS Size - All Materials of Construction

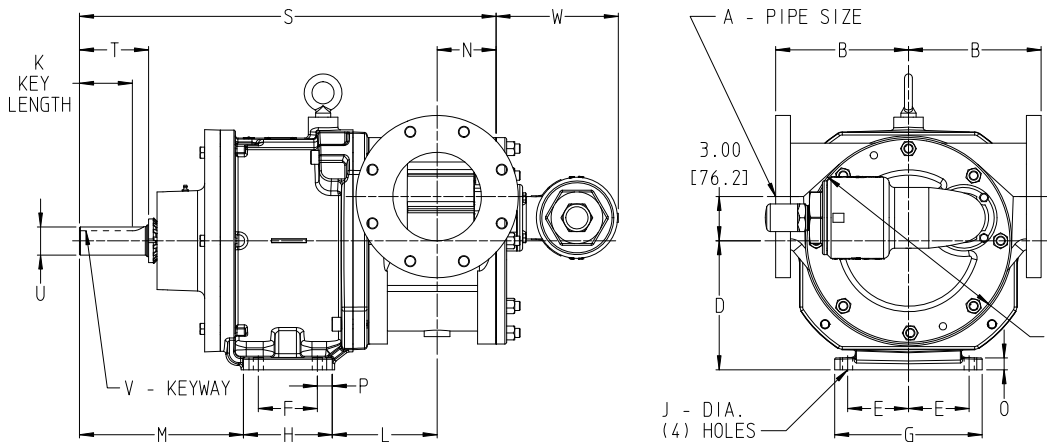

Model	A (in)	B	C	D	E	F	G	H	J	K	L	M	N	O	P	S	T	U ^④	V	W	
QS8124A	②③ 6	in	9.00	14.00	8.75	4.12	4.00	10.00	6.00	0.69	3.58	7.12	11.13	4.00	0.80	1.00	28.25	4.68	1.94	.50 x .25	8.29
QS8123A		mm	229	356	222	105	102	254	152	18	91	181	283	102	20	25	718	119	49		211
QS8127A																					

① Series 8124A ports are tapped for standard (NPT) pipe.

② Series 8124A, sizes LQ, LL and LS ports are suitable for use with 125# ANSI cast iron flanges or flanged fittings.

③ Series 8123A and 8127A ports are suitable for 150# ANSI steel or stainless steel companion flanges or flanged fittings.

④ When replacing on existing units, sizes L, LL and LQ may require a different size coupling half.



A Unit of IDEX Corporation

Leader in Positive Displacement Pumping Solutions.

Innovation and Experience

Viking Pump has been a pump industry leader and innovator since its founding in 1911. We continue to build on our ever growing experience delivering innovative new pumping solutions, including custom designs, to thousands of customers who use Viking® pumps in some of the world's toughest applications.

Broad Performance Range

Capacity:

0.5 to 360 M³/Hr (0.1 to 1,600 GPM)

Pressure:

0 to 172 Bar (0 to 2,500 PSI)

Temperature:

-84°C to 370°C (-120°F to 700°F)

Viscosity:

0.5 to 1,000,000 cSt (28 to 4,500,000 SSU)

Ultimate in Sealing Solutions

Viking's offering of packing, component mechanical seals, cartridge seals and sealless Mag Drive technology provides the best choices for sealing flexibility needed to provide your application a customized sealing solution every time - saving you money, time and unplanned downtime.

Material Options Matched to Application

Viking's dedicated iron and alloys foundries provide pump construction materials from cast iron to Alloy C. Application-specific materials of construction extend a pump's life significantly, while reducing maintenance and unplanned downtime, enabling increased production and a better bottom line.

Liquid Integrity Protection

Viking has developed multiple positive displacement pump principles to protect shear-sensitive liquids, and low-shear options to prevent damage to fibers, polymers and solids. Full-jacketing options provide precise temperature control throughout the pump. The Viking Mag Drive® and other seal options prevent fluid contact with air, assuring liquid integrity.

Local Applications and Engineering Support

Over 245 Authorized Viking Pump Distributors in 68 countries provide local application support and service. They are backed by Viking Application Engineers and Viking Region Managers strategically located around the world.

Quality Manufacturing

Viking uses ISO9001-2008, Six-Sigma, and Lean/Kaizen in its worldwide manufacturing and assembly processes to remove waste, reduce development costs, and deliver superior products. Dedicated Viking foundries and manufacturing facilities utilize state-of-the-art CNC equipment to assure unmatched quality is built into every pump.

Custom Designed Solutions

Viking has provided custom designed pumps to end-users and OEMs since its first pump in 1911, when Viking invented the gear-within-a-gear pumping principle to remove water from a rock quarry. Today, enabled by Viking's engineering staff, extensive applications experience and in-house foundries, more than 20% of Viking's sales are new designs or pump designs derived from one of our 40,000 active configurations. Whether you are an end-user or an OEM, Viking can provide custom designed pumping solutions to meet your specific needs.



motralec

4 rue Lavoisier . ZA Lavoisier . 95223 HERBLAY CEDEX
Tel. : 01.39.97.65.10 / Fax. : 01.39.97.68.48
Demande de prix / e-mail : service-commercial@motralec.com
www.motralec.com