

F SERIES PUMP SELECTION GUIDE



Max flow rate l/min	Pump Option	Pump inlet/outlet size	Aluminium Pumps	Poly/PVC/PVDF Pumps	Stainless/Hastelloy® Pumps	Virgin & A/S PTFE Pumps	Diaphragm Diameter
			Pump Style	Pump Style	Pump Style	Pump Style	
55	1	1/2"	Slim	500	Slim	Use option 3	7"
72	2	1/2"	Slim	Use option 3	Slim	Use option 3	10"
90	3	1/2"	Use 1"	500	710	K	10"
100	1	1"	Slim	500	Slim	Use option 3	7"
140	2	1"	Slim	Use option 3	Slim	Use option 3	10"
155	3	1"	Use 1 1/2"	500	710	K	10"
175	1	1 1/2"	Slim	Use option 2	Slim	Use option 2	10"
233	2	1 1/2"	Use option 3	500	710	K	10"
363	3	1 1/2"	Slim	500	Slim	Use 2"	12"
250	1	2"	500**	500	710**	K	10"
390	2	2"	Slim	500	Slim	Use option 3	12"
544	3	2"	500	500	710	K	14"
454	1	3"	Slim	500	Slim	Use option 2	12"
680	2	3"	500	500	710	K	14"
908	3	3"	Duplex 500	Duplex 500	Duplex 710	Duplex K	14"

Pumps marked with ** can be supplied in Slim pump style upon request (15% reduction in flow rate).

The company policy of continued product improvement through research and development means that the information contained in this brochure may change. Please ask for confirmation of technical data when ordering.



Certificate No. 6597



Literature BRO. UK Rev. C

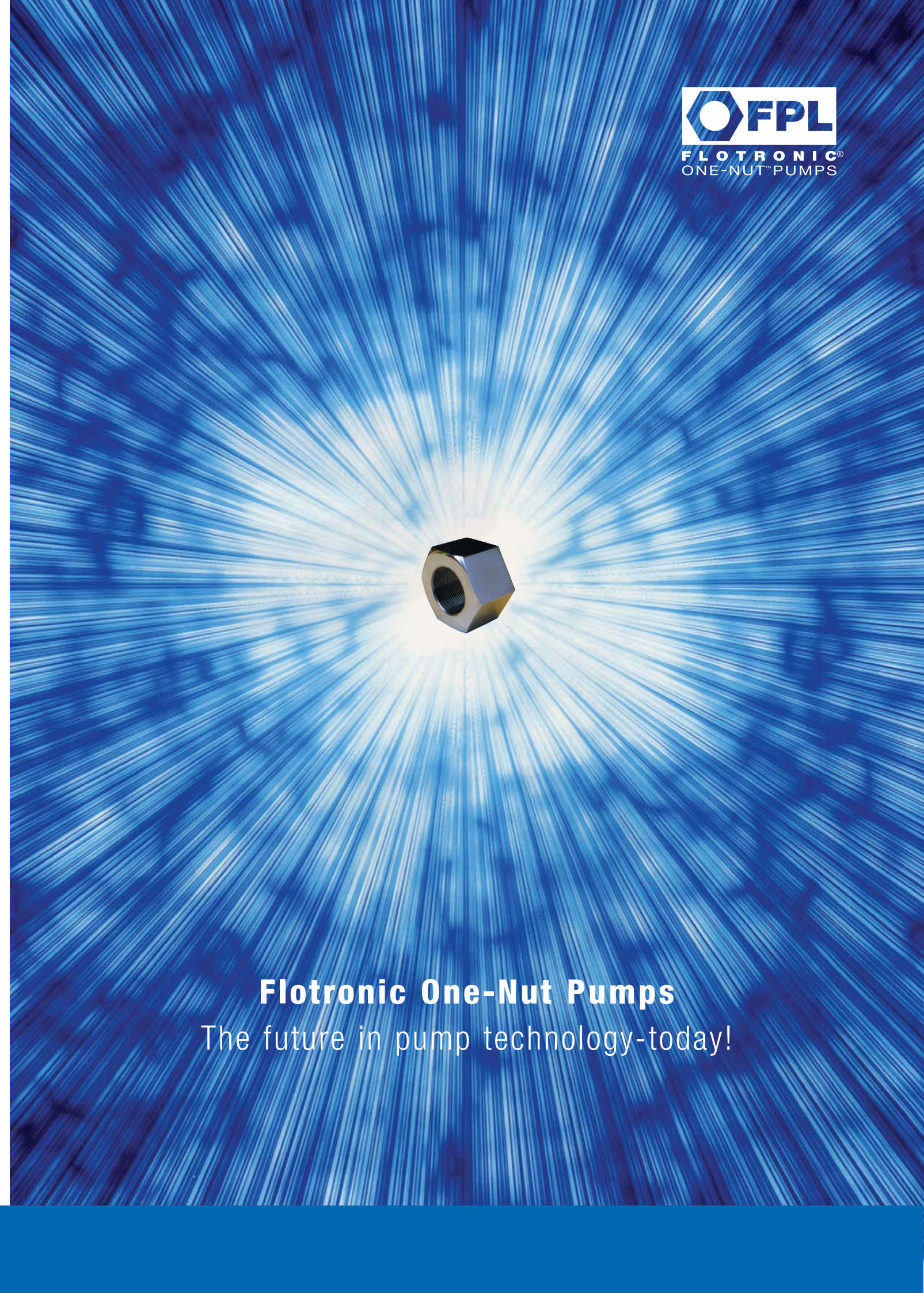

Flotronic One-Nut Pumps
 The future in pump technology-today!

INTRODUCTION

Fast maintenance air-driven Double Diaphragm Pumps for both process and simple transfer applications.

Flotronic is a world leading manufacturer of air-operated Double Diaphragm Pumps and inventor of the revolutionary One-Nut design - a concept which is transforming the way pumps are being used throughout industry today.

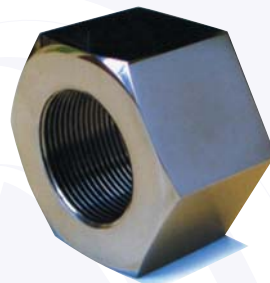

The One-Nut Double Diaphragm Pump, unique to Flotronic, takes pump performance far beyond traditional style Double Diaphragm pumps. This fast maintenance concept literally turns the conventional pump inside out! Fluid passes between the diaphragms directly through the centre of the pump with air pressure operating on the outside. The pump is held together by one nut on the opposite side of the pump to the external air valve. This design allows in-line diaphragm replacement to be accomplished in less than 15 minutes, with a complete stripdown and rebuild possible in less than 20 minutes. Using One-Nut pumps, engineers can significantly reduce process downtime and provide vast savings in maintenance costs, without compromising on pump performance.

Diaphragm lifetime is now so good, these pumps are often used instead of centrifugal or other process pumps.

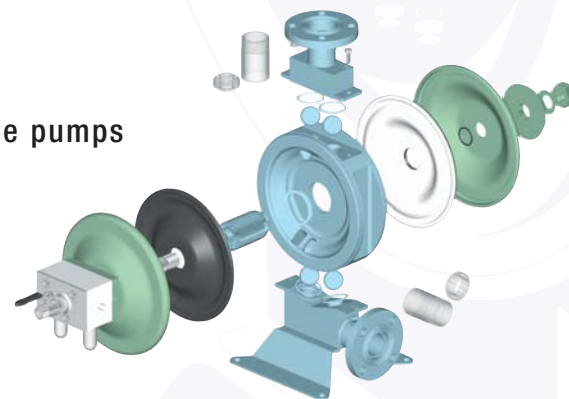

How to use this guide.

This guide is designed to assist you in the straightforward specification and ordering of the award winning F Series range of One-Nut pumps from Flotronic.

Use the charts on pages 6 and 7 to identify the pump option for your application by size and/or flow rate. Then choose the style and material required from pages 8 and 9. Select diaphragms, air system and connections from pages 10 and 11. Finally, select that all important upgrade by selecting products from pages 12 and 13. For ease of ordering, create your required Pump Code using the Coding Chart on pages 14 and 15. The simple pump selection guide on the back page gives an overview of the entire range.



The Flotronic F Series.

A range of air operated Double Diaphragm pumps with:

Multi-million cycle 'short stroke' one piece bonded diaphragms.

15 minute 'in-line' maintenance.

PTFE diaphragms as standard.

Any inlet/outlet connection you require.

2/3 days ex works UK.

Low price spares ex-stock.

Worldwide after-sales service.



Flotronic's state-of-the-art manufacturing facility



Flotronic Pumps are used in process applications worldwide

Use Flotronic Double Diaphragm Pumps for BOTH simple transfer and continuous duty 24/7 process applications using PTFE faced multi-million cycle diaphragms as standard.

A proven concept used over the last twenty years by the world's major manufacturing companies including:

Akzo	Givaudan
Apetito	Glaxo SmithKline
Astra Zeneca	ICI
Avon Cosmetics	Jaguar
BASF	Kerry Foods
Bayer	Kodak
BMW	Lotus
Britvic	Merck
BNFL	Nestlé
Budelpack	Novartis
Cadburys	Oscar Mayer
Coca-Cola	Pepsi Cola
Colgate Palmolive	Pfizer
Courtaulds	Proctor & Gamble
Cray Valley Resins	Quest
Cussons	Rhodia
DOW	Rhone Poulenc
Eli Lilly	Robinson Brothers
Esso	Sias Foods
Exxon	Unilever
Ford	Wyeth
Geest	

CE The range of products shown in this literature complies with the relevant sections of the machinery directive 98/37/EC and carry the CE mark.



THE ONE-NUT CONCEPT

The 'inside out' concept allows fluid to pass 'between the diaphragms', directly through the centre of the pump.

Air pressure operates 'on the outside'. The benefits are:

Longer lasting diaphragms

A significantly reduced stroke length allows use of thicker / stronger PTFE diaphragms as standard. Nitrile, Viton® and EPDM are also available.

Faster maintenance

Fifteen minutes to change diaphragms by the removal of just one nut and without disconnecting the pump from the pipework.

Lower cost spares

Less than half the quantity of spare parts than any equivalent pump and interchangeability of most air system parts between different series of pumps.

No lubrication

A unique, patented air system incorporating a bolt on spool valve, including manual override buttons, eliminates costly internal air mechanisms and mid position stall normally associated with Double Diaphragm Pumps.

Greater inherent safety

Plastic parts are kept within metal containment and potential leak paths are reduced to a minimum. Even under ATEX conditions pumps can be maintained 'in the zone' up to Zone I using anti-static PTFE-faced diaphragms.

Flotronic Pumps don't need:

Clamp bands

We utilise self-aligning bead seals integral with the diaphragms.

Complicated air mechanisms

We simply bolt on a spool valve.

Lubrication

We use self-lubricating PTFE parts.

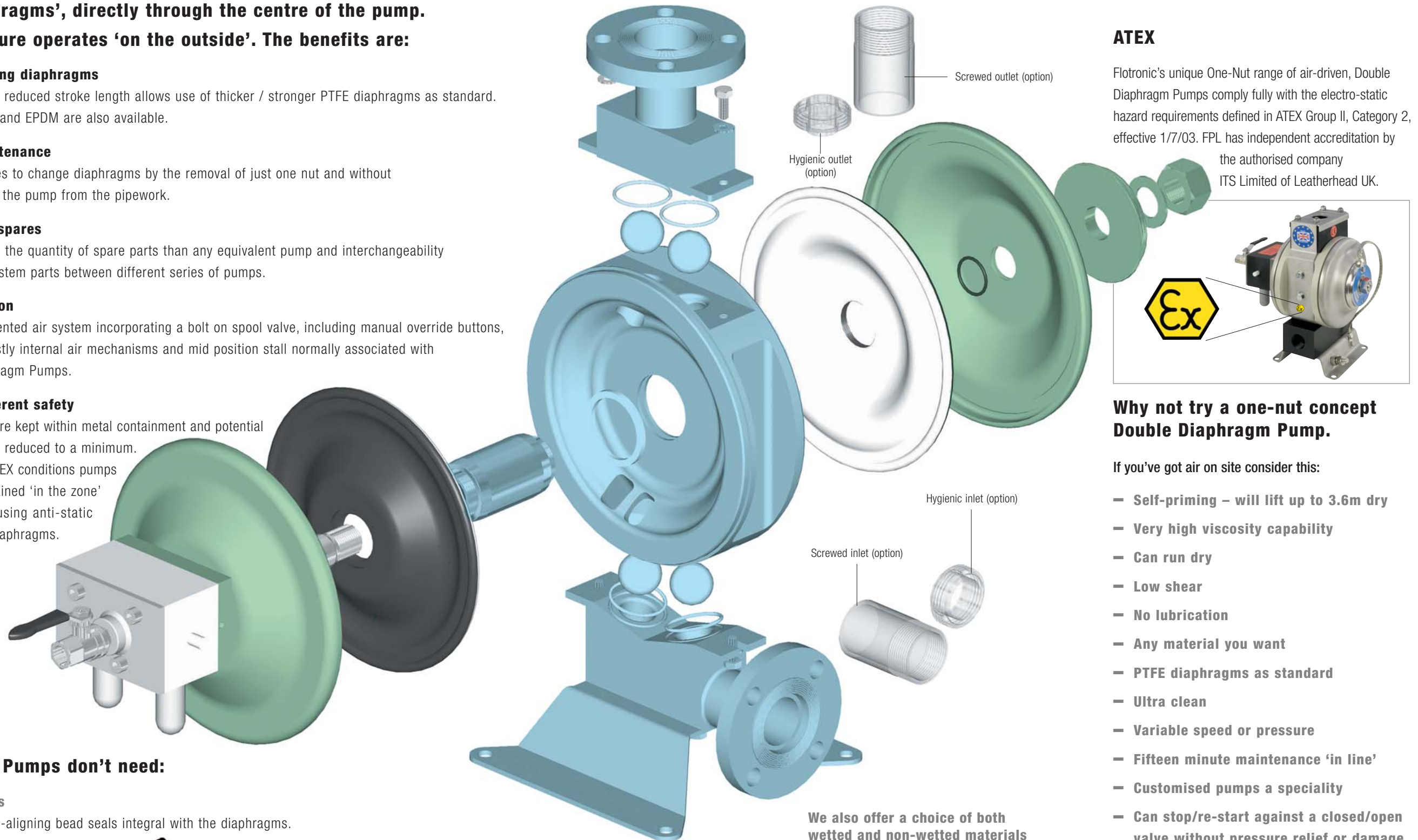

We also offer a choice of both wetted and non-wetted materials

- **Wetted parts**
Aluminium, Polypropylene, PVC, PVDF, 316 stainless steel, exotic metals and solid virgin or anti-static PTFE with PTFE, Viton®, EPDM or Nitrile rubber diaphragms, balls and seals.
- **Non-wetted parts**
Version E = Painted carbon steel – Version S = Stainless steel.

ATEX

Flotronic's unique One-Nut range of air-driven, Double Diaphragm Pumps comply fully with the electro-static hazard requirements defined in ATEX Group II, Category 2, effective 1/7/03. FPL has independent accreditation by the authorised company ITS Limited of Leatherhead UK.



Why not try a one-nut concept Double Diaphragm Pump.

If you've got air on site consider this:

- Self-priming – will lift up to 3.6m dry
- Very high viscosity capability
- Can run dry
- Low shear
- No lubrication
- Any material you want
- PTFE diaphragms as standard
- Ultra clean
- Variable speed or pressure
- Fifteen minute maintenance 'in line'
- Customised pumps a speciality
- Can stop/re-start against a closed/open valve without pressure relief or damage. (No by-pass required)



FLOW RATES

Flow rates up to 200 UKGPM (908 l/min) are available.
We offer three sizes of pump for every size of pipe:
Option 1, option 2 and option 3.

All materials of pumps are available in all sizes of pipe from 1/2" to 3" – (see pump selection guide on back page.) This allows a 'perfect' pump selection rather than a 'nearest equivalent' and gives you the best possible opportunity to keep pump size and price to a minimum. 3/4", 1 1/4" and 2 1/2" size pumps available upon request.

All pumps are self priming (12ft/3.6m dry and 25ft/7.6m wet). Pumps with upgrades * A B, reduce flow performance by 10%. Diaphragm pumps operate on a 1:1 ratio basis. The air pressure supplied will equal the maximum discharge pressure from the pump. Work out your total 'head' and available air (or nitrogen) supply pressure to see maximum pump performance from the graphs shown here.

At the time of going to press all information relating to pump performance is considered to be accurate resulting from extensive testing and is given in good faith. The 3" pumps were not subject to air consumption testing and the information shown is calculated. If air consumption is critical please consult Flotronic Pumps before ordering.

Example:
 With a suction lift of 2m the pumping capacity is reduced by approximately 10%. Remember to consider friction losses as part of the flow rate calculation.

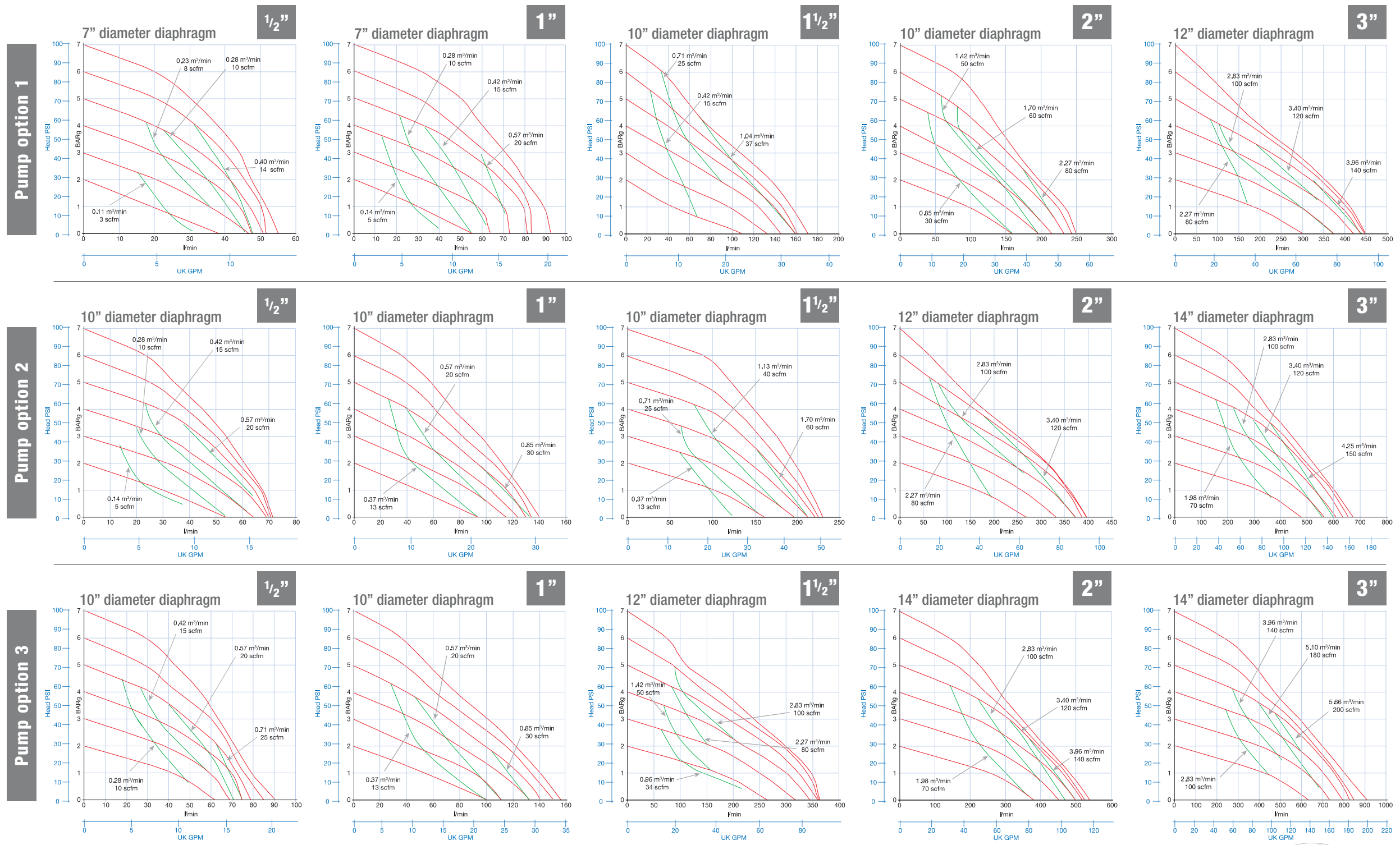
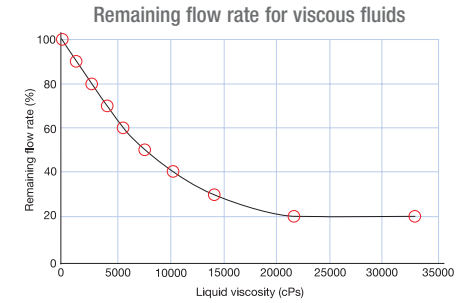
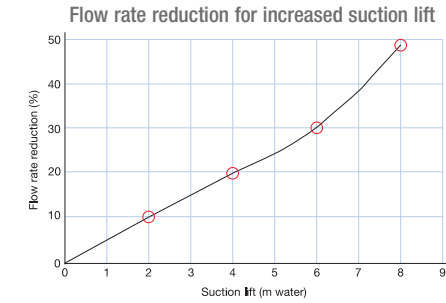

Choose your pump style and material overleaf



THE PUMPS

Choose a style and material of pump to suit your application

Slim Style



F Series award-winning metal pumps

Machined from solid material, these compact and self-draining pumps are available in 316 stainless steel, aluminium and also exotic metals, including Hastelloy®.

These pumps can be used in a wide range of industries including chemical, cosmetic, paints, pharmaceutical, adhesive and hygienic applications.

Recently voted winner of the prestigious Food Hygiene Award for Food Processing and Manufacture.

Only 'one nut' to access diaphragms with pump 'in-line'

Only four nuts and bolts to access balls and seats (where fitted)

Only four bolts to maintain air valve with pump 'in-line'

Max operating temp 121°C (250°F) with high temp diaphragm (specify H as 6th digit in pump code)

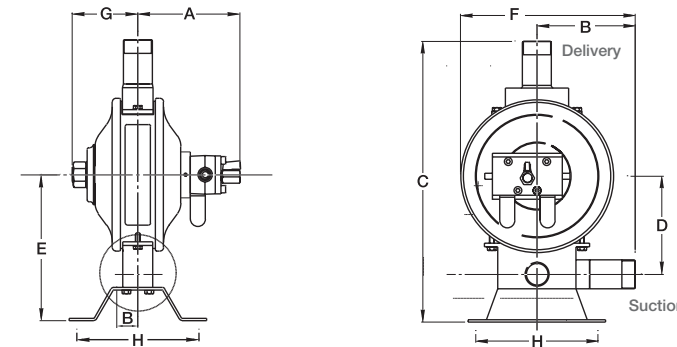

Maximum operating pressure 7.2 bar (105 PSIG)

Stainless steel range										Diaphragm Diameter
Size	A	B	C	D	E	F	G	H	WT/kg	
1/2" - 1"	159	117	332	109	175	215	92	160	17	7"
1/2" - 1"	172	129	425	145	217	255	109	203	25	10"
1 1/2" - 2"	207	163	466	163	242	290	109	203	28	10"
1 1/2" - 2" - 3"	305	180	600	190	300	350	187	250	75	12"

Aluminium range										Diaphragm Diameter
Size	A	B	C	D	E	F	G	H	WT/kg	
1/2" - 1"	159	89	312	109	175	187	92	160	13	7"
1/2" - 1" - 1 1/2" - 2"	172*	35	437	171	256	254	109	203	22	10"
1 1/2" - 2" - 3"	305	125	520	190	300	295	187	250	50	12"

Dimensions in mm

500 Style

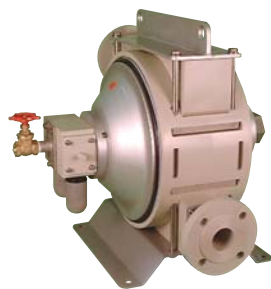

F Series Polypropylene, PVC, PVDF and aluminium pumps

Solid blocks of plastic supported by metal air domes, top and bottom plates and through studs offer safety without compromising fast maintenance.

Normally used for solvents/chemicals and dyes and often as a less expensive option for stainless steel.

Only 'one nut' to access diaphragms with pump 'in-line'

Only four nuts to access balls and seats

Only four bolts to maintain air valve with pump 'in-line'

Max operating temp 80°C (176°F) for Polypropylene, PVC, PVDF pumps

Max operating temp 121°C (250°F) for Aluminium pumps fitted with high temp diaphragms (specify H as 6th digit in pump code)

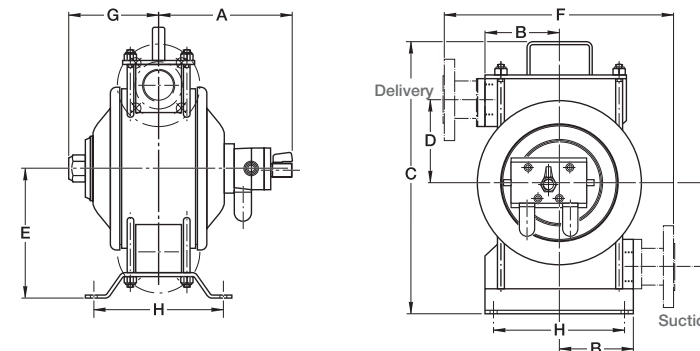

Maximum operating pressure 7.2 bar (105 PSIG) *Vertical delivery on these pumps

Polypropylene, PVC, PVDF & Aluminium										Diaphragm Diameter
Size	A	B	C	D	E	F	G	H	WT/kg	
1/2" - 1"*	183	87	323	110	178	225	116	130	13	7"
1/2"	190	114	360	115	170	355	145	203	17	10"
1"	200	114	390	121	186	355	145	203	18	10"
1 1/2"	230	114	419	129	200	355	145	203	19	10"
2"	230	163	450	132	215	355	145	203	20	10"
1 1/2" - 2" - 3"*	323	150	522	189	295	323	210	220	50	12"
2" - 3"	350	190	530	148	270	550	235	330	75	14"

Dimensions in mm

710 Style

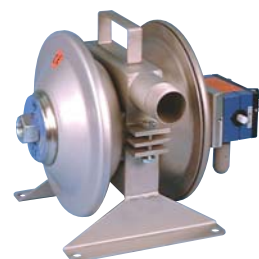

F Series stainless steel and exotic metal pumps

Fabricated 316 or 304 stainless steel or Hastelloy® on all wetted metal parts offers unrivalled versatility.

These pumps are used extensively throughout industry from acids to adhesives, cosmetics to ceramics, petrochemicals to paper stock and solvents to solids in suspension. Even dairy and food stuffs.

Only 'one nut' to access diaphragms with pump 'in-line'

Only two nuts and bolts to access balls and seats

Only four bolts to maintain air valve with pump 'in-line'

Max operating temp 121°C (250°F) with high temp diaphragm (specify H as 6th digit in pump code)

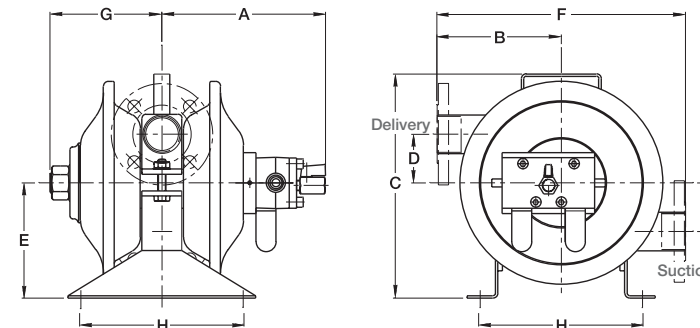

Maximum operating pressure 7.2 bar (105 PSIG)

Stainless Steel & Exotic Metals										Diaphragm Diameter
Size	A	B	C	D	E	F	G	H	WT/kg	
1/2"	190	156	282	60	146	311	145	203	18	10"
1"	200	156	282	60	146	311	145	203	18	10"
1 1/2"	230	156	282	60	146	311	145	203	19	10"
2"	230	156	282	60	146	311	145	203	20	10"
2" - 3"	350	250	460	108	230	500	235	254	80	14"

Dimensions in mm

K Style



F Series Chemflo virgin and anti-static PTFE pumps

A solid block of virgin or anti-static PTFE housed completely inside an outer metal 'Pressure Vessel' of carbon or stainless steel gives inherent safety whilst retaining 'one nut' maintenance.

Used for extremely hazardous acids and chemicals where only PTFE can be used and often in pilot plants or as emergency pumps where chemicals are unknown.

The ultimate solid PTFE Double Diaphragm Pump.

A 90° PTFE-lined elbow will fit between the pump legs as shown.

(This part can be supplied by Flotronic if required).

Max operating temp 121°C (250°F) with high temp diaphragm (specify H as 6th digit in pump code)

For more information, go to www.flotronicpumps.co.uk

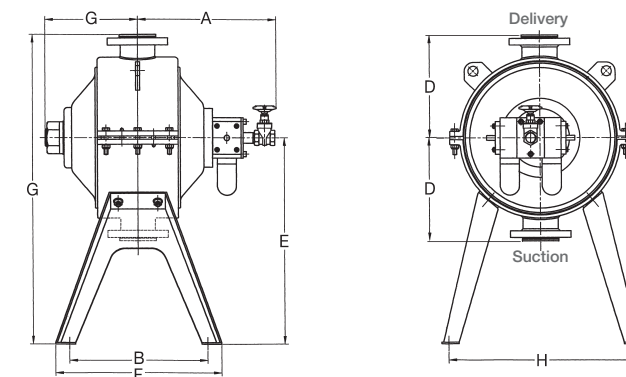

Maximum operating pressure 7.2 bar (105 PSIG)

Chemflo Virgin & Anti-Static PTFE										Diaphragm Diameter
Size	A	B	C	D	E	F	G	H	WT/kg	
1"	200	235	550	180	370	300	140	325	42	10"
1 1/2"	230	235	550	180	370	300	140	325	45	10"
2"	230	250	570	180	390	315	140	345	48	10"
2" - 3"	350	350	580	260	520	420	235	470	95	14"

Dimensions in mm

Choose your diaphragms and air system overleaf

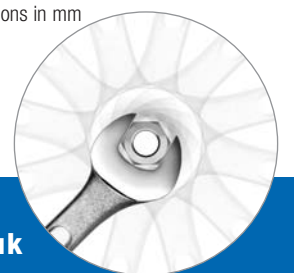

DIAPHRAGMS

Choose a Diaphragm for your pump.

Don't forget – Flotronic leads the way in bonded diaphragm technology, introducing one piece PTFE faced rubber diaphragms to the market in 1982 using technology straight from the first NASA space shuttle launch.

The key to a successful PTFE diaphragm is a very short stroking action.

Flotronic uses shortstroke technology to achieve a multi-million cycle 'norm'.

Our standard diaphragm is PTFE which covers 95% of all applications.



Virgin PTFE

Option code T (6th digit in pump code). The perfect diaphragm, flexible yet corrosion resistant and as a one piece achieving multi-million cycles as standard.

Ultimate PTFE

Option code U (6th digit in pump code). A diaphragm for particularly difficult applications where PTFE is required but virgin lifetime is limited.

Anti-static PTFE

Option code A (6th digit in pump code). A diaphragm for ATEX applications ensuring 'in the zone' maintenance is still allowed. Pump can be maintained out of zoned area using virgin PTFE.

Viton®

Option code V (6th digit in pump code). Is used with aggressive media where corrosion and abrasion are a combined problem and PTFE is proved to be unsuitable.

Nitrile

Option code N (6th digit in pump code). Are you sure? Why not use PTFE? Rubber is only really essential for very high abrasive media and has low corrosion resistance.

EPDM

Option code E (6th digit in pump code). Not commonly used today as superseded by virgin PTFE, but available upon request.

Diaphragms - legislation and safety issues.

Flotronic has made huge advances in PTFE diaphragm technology and has over 50 diaphragms to suit every application.

The ULTIMATE diaphragm range is available for all styles of Flotronic pump.

Remember the emphasis of the design is around a very short stroke – less than 50% of the best alternative – which means the PTFE is not working (and therefore being stressed) in the manner normally associated with long stroke Double Diaphragm Pumps. This short stroke gives the benefit of multi million cycle operations and the company has just exceeded 40 million cycles on a PTFE diaphragm.

The emphasis of the ULTIMATE range is for those highly difficult applications where permeation, even of PTFE, can be an issue, or perhaps high temperatures up to 150°C. High viscosity, sticky products, cleaning in place (high pressure) and/or even where solids in suspension and subsequent mechanical damage issues are a problem for the conventional virgin PTFE material.

Flotronic takes its CE obligations very seriously indeed and ask that you in turn follow the Certificate of Incorporation requirements of CE equipment into your own factories and workshops. Do not accept imitation product and buy only from Flotronic or its distribution network. Do not compromise your liability insurances by purchasing 'pirate' spares.



Flotronic has the diaphragm solution for you. You only have to ask.

AIR SYSTEMS

Choose an air system for your pump.

Our unique design incorporates a self-lubricating bolt-on aluminium* spool valve including manual override buttons. Latest designs eliminate costly internal air mechanisms and mid-position stall normally associated with Double Diaphragm Pumps. No lubrication required.

Amongst the quietest Double Diaphragm Pumps on the market, our aluminium or Polypropylene air systems are supplied as standard, (see pump selection guide on back page). You can upgrade the air system as shown below.

*Pump becomes aluminium-free if fitted with an alternative air valve (no aluminium content whatsoever).



Aluminium

Standard on pumps with ISO air valve.



Polypropylene

(Upgrade N in pump code).



PTFE

(Upgrade T in pump code)
Or stainless steel
(upgrade K in pump code).



It takes just two minutes to replace the spool without dismantling the pump.

Non-wetted parts

We offer a choice of non-wetted parts on every pump. You can specify our E version with air domes, nuts, bolts, washers, handle and footplates in painted carbon steel or alternatively, our S version with the same parts in stainless steel. (Over 40% of the pumps we supply are upgraded to stainless steel non-wetted parts).

If you would like these parts in stainless steel on your pump, specify S as the 9th digit in the pump code.

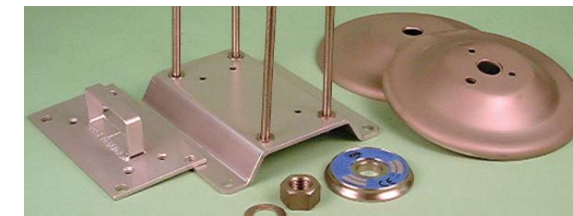

Connections

Any standard inlet/outlet connection can be supplied. BSPT, NPT, RJT, IDF, ANSI 150, DIN, BS flanges. Don't hesitate to ask for your preferred connection style.



Consider our unique upgrades and special features overleaf



IMPORTANT UPGRADES

Now you have selected your standard pump, don't forget we also supply vital additional equipment to cover all your pumping requirements.

Flotronic has a great deal of experience in providing total pumping solutions world-wide. Whether you require air filter regulators, rupture protection systems, alarms, integral pulsation dampers – even pump trolleys, we manufacture and supply a wide range of crucial additional elements, which meet or exceed all relevant performance and safety regulations globally. Our customers' most popular upgrades are pictured here. For the full list refer to the last column of the coding chart on page 15.



Upgrade A

Sentinel alarm system

Incorporating the Guardian interchamber (upgrade B), our alarm systems are entirely pneumatic (no electrics whatsoever). A choice of alarm or pump shutdown system is available alerting diaphragm failure. Standard alarm is a pneumatic horn and visual indicator.

Upgrade F

Air filter regulator

Accurately control pump air pressure to achieve optimum performance by simply bolting on a filter regulator.



Upgrade O

ATEX

Don't forget to tell us if you need ATEX certification, and to what level.



Upgrade * or B

Low-cost rupture protection system

The Guardian rupture protection system can be fitted to all Flotronic Pumps. With this system a secondary chamber is created by an additional PTFE diaphragm behind each of the primary pump diaphragms to capture liquid upon primary diaphragm rupture. This chamber can be in low-cost Polypropylene (upgrade *) or a material to match the pump wetted body (upgrade B) both with PTFE diaphragms.

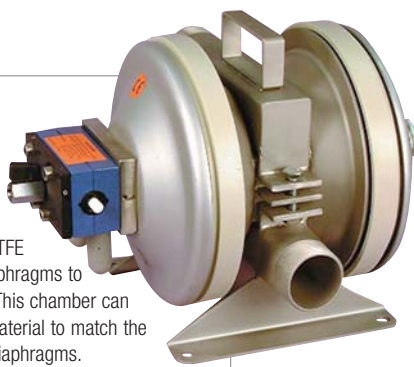

Upgrade C

Pump counter system

All pumps can easily be modified to count and stop within an accuracy of +/-2%. This pneumatic counter simply attaches to the pump air system in a stainless steel enclosure.

Upgrade G

Good food pump

(Applies to pumps with 14" diaphragms)
Designed for either 'quick strip' or 'cleaning in place' (CIP) and available in either 304 or 316 stainless steels, in a matt or electro-polished finish with a choice of hygienic connections. Designed for 'tool-free' maintenance where a strip down and rebuild in ten minutes can be achieved by integral 'T' bars and no other tooling. Used for low-shear pumping of viscous and particulate food products. Capable of handling solids up to 25mm (i.e. fruit, vegetable pieces), soups and sauces.



Upgrade J

Integral hot water jackets

Flotronic Pumps and dampers can be steam/hot or cold watered jacketed without fuss.



Upgrade P

Pulsation dampers

Dampers can be supplied integrally mounted on an FPL pump, as on the water-jacketed pump above, or individually to remove up to 95% of a given pulse on normal air supply pressure with no charging necessary. Dampers are provided in stainless steel, virgin or anti-static PTFE, PVDF, Polypropylene, aluminium or exotic materials with virgin or anti-static PTFE diaphragms as standard.

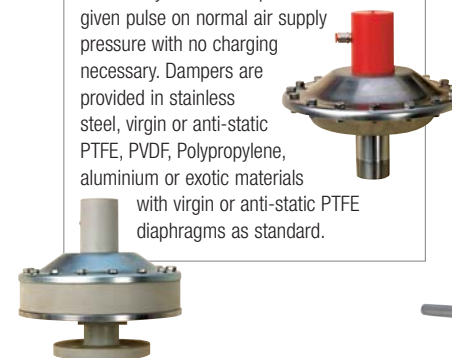

Upgrade W

Pump trolleys

Two or four wheel trolleys are available for easy pump transportation. A wide range of customised trolleys is available.



CUSTOMISED PRODUCTS

If our products don't exactly meet your requirements we can modify them for you.

We have an excellent facility for customising products whether it be simply a different connection, material, painting specification, or more complicated locking arrangements, pipework, valves etc.

The pump shown was designed and manufactured for an international pharmaceutical company. It has an integral pulsation damper and diaphragm rupture protection and alarm system (including the damper), filter regulator with gauge, adjustable anti-vibration mounting feet, and no aluminium content, whilst being totally pneumatic (no electrics), self-contained and portable.



For a pump built to your specification, just ask, we can usually help you.

Ancillaries.

Dip tube package

For safe, cost-effective, clean and efficient media transfer.



Flexible hoses

Supplied by the metre in various materials and sizes with connections to suit.



Strainers

Supplied fitted to the pump inlet to remove unwanted solids to prevent premature diaphragm failure.

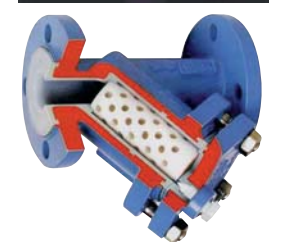

Create your order code overleaf



CODING CHART

A pump specification for every occasion. Create your pump code using this list - the code must be a minimum of 12 digits with upgrades added at the end. Enter the code at the bottom of each column. (See example).

Series	Pump option	Connection and size	Body and manifolds	Thrust tube (The wetted part connecting the diaphragms)	Diaphragms/divider seals	Balls	Seats	Version (Non-wetted parts)	Connections	Upgrades and special features
F - All pumps	1	1 - 1/2"	3 - Aluminium	5 - 304 stainless steel	T - PTFE	T - PTFE	T - PTFE	E - Painted carbon steel	BSP - BSPT screwed	* - Low cost Guardian barrier. Not available on Polypropylene pumps. Use code B for Polypropylene pumps A - Sentinel alarm pump B - Guardian barrier pump C - Flomix counter pump D - Manual pump drains E - Electro-polished pump F - Filter regulator G - Tool-free maintenance (pumps with 14" dia diaphragms only) H - Hand-polished pump I - Gauge on Barrier System J - Jacketed pump K - Stainless steel air valve on pump L - Low pressure 0.5 BARg operation (4 valve amplifier system) M - Anti-vibration mounts N - Polypropylene air valve on pump O - ATEX Certified pump P - Pulsation damper on pump Q - R - Reinforced diaphragms (suction pressure above 0.5 BARg) S - Short thrust tube in pump (extra self-prime capability up to 15ft dry) T - PTFE air valve on pump U - One size smaller outlet connection V - Vertical connections instead of horizontal W - Two wheel trolley X - Special contract identity [†] Y - One size larger inlet connection Z - One size larger air valve fitted than normal † Special pump or pump with more than four upgrades specified (Engineering will allocate a three digit code after the X) Note: Specify upgrades in alphabetical order.
	2	2 - 3/4"	5 - 304 stainless steel	6 - 316 stainless steel	N - Nitrile	N - Nitrile	P - Polypropylene	S - Stainless steel	NPT - NPT screwed	
	3	3 - 1"	6 - 316 stainless steel	P - Polypropylene	P - Polypropylene	V - Viton®	V - Viton®		150 - ANSI 150 flanged	
		4 - 1 1/4"		P - Polypropylene	T - PTFE	E - EPDM	E - EPDM		D16 - DIN 16 flanged	
		5 - 1 1/2"		T - PTFE	D - PVDF	H - High temp PTFE	6 - 316 stainless steel		BSE - B S table 'E' flanged	
		7 - 2"		D - PVDF	U - PVC	A - Anti-static PTFE	A - Anti-static		BSF - B S table 'F' flanged	
		8 - 2 1/2"		U - PVC	A - Anti-static PTFE	U - Ultimate PTFE	G - Glass-filled PTFE		BSH - B S table 'H' flanged	
		9 - 3"		A - Anti-static PTFE	N - Natural poly	H - Hastelloy® C	W - Weighted Nitrile		RJT - RJT dairy fitting	
				N - Natural poly	H - Hastelloy® C				TRI - Triclover dairy fitting	
				H - Hastelloy® C	C - Ceramic				851 - Din 11851 dairy fitting	
								IDF - IDF (ISS) dairy fitting		
								ISS - ISS (IDF) dairy fitting		
								CAM - Camlock male part		
								SMS - SMS fitting		
								BWB - Butt weld		

Enter your codes in the boxes



Example code: To order this pump configuration (as pictured left) the code would be:

F 3 7 A A A T A S 150 AOP

This 2" pump, in pump option 3 (flow rate of 544 l/min) has anti-static PTFE body and manifolds, thrust tube and diaphragms, PTFE balls and anti-static PTFE seats. Its non-wetted parts are in stainless steel and it has ANSI 150 flanged connections. The pump is fitted with a pneumatic alarm (horn) and visual indicator (upgrade A), is ATEX certified (upgrade O) and has an integral pulsation damper fitted (upgrade P).

Note: Both the pump and the damper have the secondary anti-static PTFE diaphragm interchamber to capture liquid upon primary diaphragm rupture. Don't forget upgrade A incorporates upgrade B automatically.

Spares, service and after-sales support

Our policy is to supply spare parts on immediate overnight delivery. Spares can be purchased individually (no minimum order charge) or as a **MINI-KIT** or a complete **REPAIR-KIT**.

Assistance is available through our technical sales or service personnel to help you to achieve maximum operating life from your Flotronic Pump.

