

TSURUMI PUMP

17200142/B-10091-2



motralec

4 rue Lavoisier . ZA Lavoisier . 95223 HERBLAY CEDEX

Tel. : 01.39.97.65.10 / Fax. : 01.39.97.68.48

Demande de prix / e-mail : service-commercial@motralec.com

www.motralec.com

TSURUMI PUMP

PL Submersible, Semi-Vortex, Water Feature Pump

VANCS™

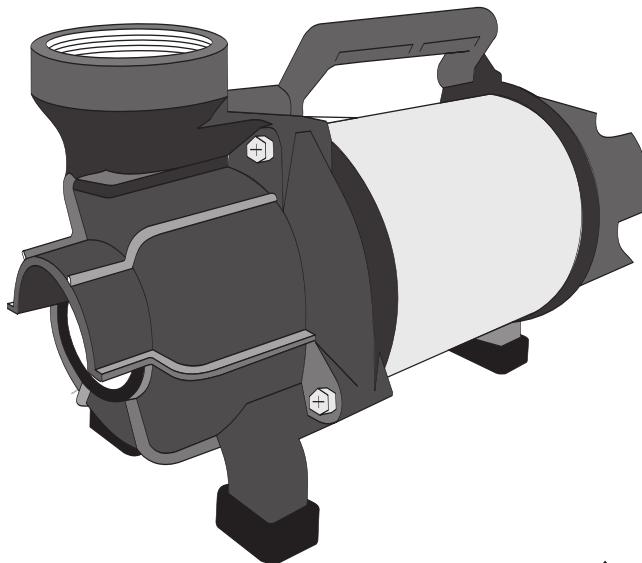

Distributed By:



INSTALLATION, OPERATION & MAINTENANCE MANUAL

MADE IN JAPAN



TSURUMI PUMP

Introduction

PL

Submersible, Semi-Vortex, Water Feature Pump

This manual provides information and procedures to safely install, operate and maintain this TSURUMI model. For your own safety and protection from injury, carefully read, understand and observe the safety instructions described in this manual. THE INFORMATION CONTAINED IN THIS MANUAL WAS BASED ON MACHINES IN PRODUCTION AT THE TIME OF PUBLICATION. TSURUMI RESERVES THE RIGHT TO CHANGE ANY PORTION OF THIS INFORMATION WITHOUT NOTICE.

Nameplate

A nameplate listing the Model Number, Manufacture Date, and Serial Number is attached to each unit. Please record the information found on this plate so it will be available should the nameplate become lost or damaged. **When ordering parts or requesting service information, you will always be asked to specify the model, manufacture date and serial number of the unit.**

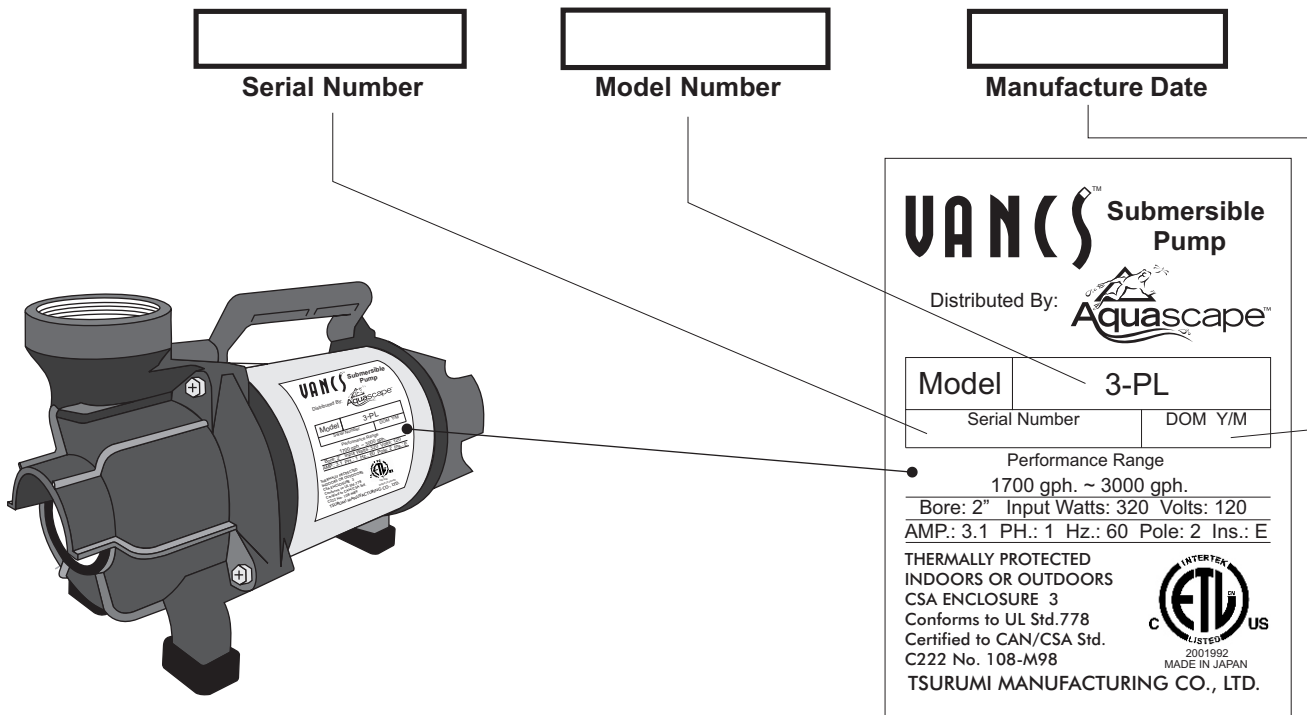

WARNING

To reduce risk of electric shock, connect only to a properly grounded, grounding-type receptacle.

Risk of electric shock - This pump has not been investigated for use in swimming pool areas.

An acceptable motor-control switch shall be provided at the time of installation according to local codes and regulations.

To reduce risk of electric shock, see instruction manual for proper installation.

Attention - This pump may automatically restart. Prior to working on the pump or control panel all supply circuits must be disconnected.

Attention - Risk of shock - Do not remove cord and strain relief.

Keep this manual or a copy of it with the machine. If you lose this manual or need an additional copy, please contact TSURUMI. This machine is built with user safety in mind, however, it can present hazards if improperly operated and serviced. Follow operating instructions carefully! If you have questions about operating or servicing this equipment, please contact TSURUMI.



TSURUMI PUMP

PL Submersible, Semi-Vortex, Water Feature Pump

Section 1: Operation

1.1	<i>Safety Information</i>	1-2
1.2	<i>Names of Parts</i>	1-3
1.3	<i>Prior to Operation</i>	1-3
1.4	<i>Major Standard Specifications</i>	1-4
1.5	<i>Standard Specifications (60 Hz)</i>	1-4
1.6	<i>Installation</i>	1-5
1.7	<i>Electrical Wiring</i>	1-6
1.8	<i>Electrical Circuit Diagrams</i>	1-7
1.9	<i>Operation</i>	1-8
1.10	<i>Maintenance and Inspection</i>	1-10
1.11	<i>Disassembly and Reassembly</i>	1-13
1.12	<i>Troubleshooting</i>	1-15

1.1 Safety Information

This manual contains WARNING, CAUTION, ATTENTION, COUNTERMEASURE and NOTE, callouts which must be followed to reduce the possibility of personal injury, damage to the equipment, or improper service.

WARNING indicates a potentially hazardous situation which, if not avoided, could result in death or serious injury.

 **WARNING**

NEVER operate the pump while it is suspended in the air. The recoil may result in injury or other major accident.

CAUTION indicates a potentially hazardous situation which, if not avoided, may result in minor or moderate injury.

 **CAUTION**

In case of very excessive vibration, unusual noise or odor, turn off the power immediately and consult with your nearest dealer or TSURUMI representative. Continuing to operate the pump under abnormal conditions may result in electrical shock, fire, or electrical leakage.

ATTENTION indicates a potentially hazardous situation which, if not avoided, may result in property damage.



ATTENTION: Using the product at other than rated voltage and frequency will not only lower its performance but may damage the product.

COUNTERMEASURE offers tips and suggestions to possible maintenance concerns.



COUNTERMEASURE: If the operating current exceeds the rated value, pump motor overload may be a cause. Make sure the pump has been installed under proper conditions as described in Section 1.6 *Installation*.

Notes contain additional information important to a procedure.

Note: *Confirm the rated voltage and frequency on the model nameplate.*

1.2 Names of Parts

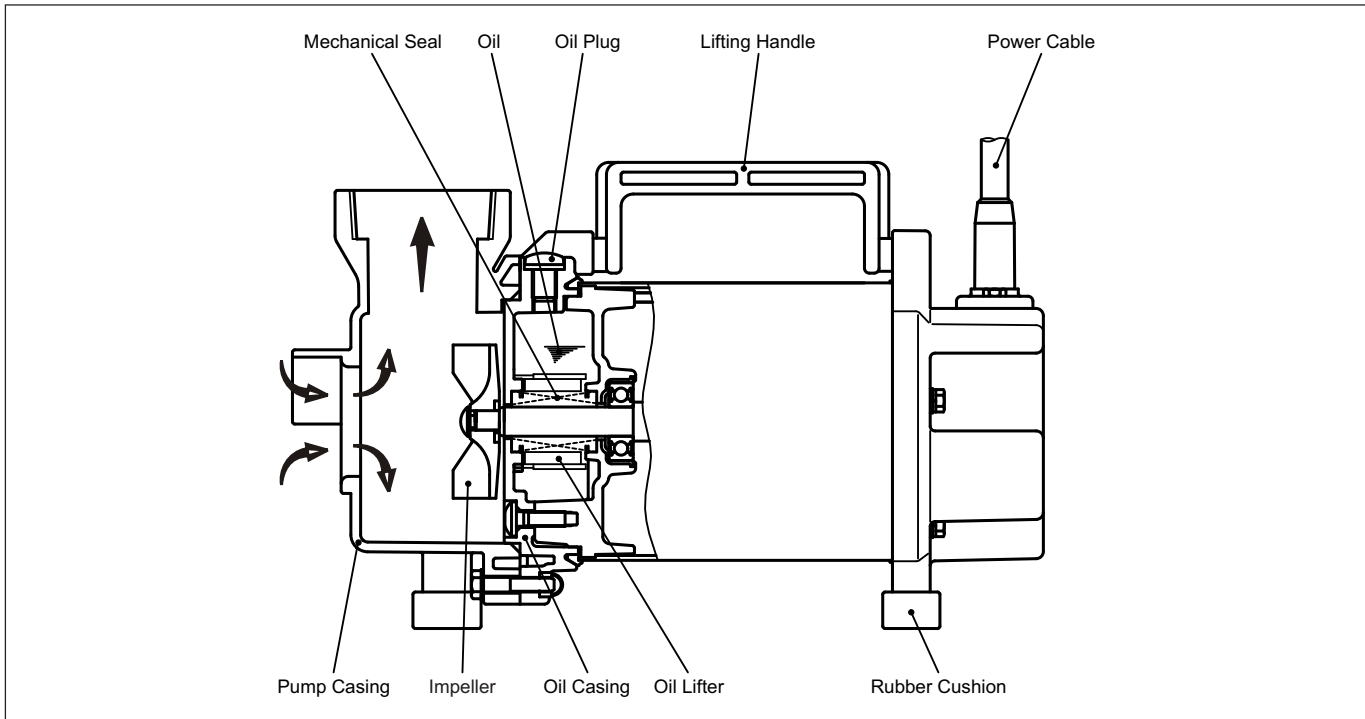

FIGURE 1.1 PARTS LISTING

1.3 Prior to Operation

When the pump is delivered, first perform the following checks:

- **Inspection**
While unpacking, inspect the product for damage during shipment, and make sure all bolts and nuts are tightened properly.
- **Specification check**
Check the model number to make sure it is the product that was ordered. Be certain it is the correct voltage and frequency.
- **Application Specifications**
Check with your local Tsurumi Distributor to verify the operating conditions fall within the conditions listed on the Name Plate.

Note: If there is any problem with the product as shipped, contact your nearest dealer or TSURUMI representative at once.

! WARNING

DO NOT operate this product under any conditions other than those for which it is specified. Failure to observe this precaution can lead to electrical shock, electrical leakage, fire, water leakage or other problems.

1.4 Major Standard Specifications

Applicable Liquids, Consistency and Temperature	Pond Water, Ground Water 32 - 104 °F (0 - 40 °C)	
Pump	Impeller	Semi-Vortex Type
	Shaft Seal	Double Mechanical Seal
	Bearing	Shielded Ball Bearing
Motor	Specification	Dry Submersible Induction Motor (2-pole)
	Insulation	Class E
	Protection System (Built-In)	Miniature or Circle Thermal Protector
	Lubricant	White Mineral Oil ISO VG32
Discharge Connection	NPT 2"	

1.5 Standard Specifications (60 Hz)

Model	Bore (inch) (mm)	Phase	Starting Method	Input Watts	Rated Current (A)	Max. Head (ft.) (m)	Max. Capacity (GPH) (m ³ /min)	Weight (lbs) (kg)
3-PL	2	1	Capacitor-Run	320	3.1	13.8	3000	12.8
	50				120V	4.21	0.189	5.8
5-PL	2	1	Capacitor-Run	620	5.6	22.8	5000	14.8
	50				120V	6.95	0.315	6.7
9-PL	2	1	Capacitor-Run	1000	8.6	34.0	6800	18.9
	50				120V	10.36	0.428	8.6

Note: The weight (mass) given above is the operating weight of the pump itself, not including the power cable.

! WARNING

If the pump is used to drain a swimming pool, the pump must be connected to a Ground Fault Interrupter (GFI).

If the pump is used in fountains, the pump must be connected to a Ground Fault Interrupter (GFI).

The pump must not be used when people are in the water.

Proper plug must be provided according to local codes and standards. Refer to wiring diagram.

DO NOT use this pump in liquids other than water, such as oil, salt water, or organic solvents.

MAKE SURE the power supply voltage agrees with the rated voltage on the Name Plate. Maximum voltage at the pump cannot exceed 126 V. Minimum Voltage at the pump cannot be less than 105 V.

DO NOT use in water temperatures outside the range of 32 - 104 °F (0 - 40 °C) which can lead to failure, electrical leakage or shock.

DO NOT use in the vicinity of explosive or flammable materials.

Use only in fully assembled state.

Note: Consult your local dealer or TSURUMI representative before using with any liquids other than those indicated in this document.

1.6 Installation

Preparing for Installation

Before installing the pump at a work site, you will need to have the following tools and instruments ready:

- Insulation resistance tester
- AC voltmeter
- AC ammeter (clamp-on type)
- Bolt and nut tighteners
- Power supply connection tools (screwdriver or box wrench)

Note: Please also read the instructions that come with each of the test instruments.

Checks to Make Before Installation

When a three-prong grounded plug is used:

Use the megohmmeter to measure the motor insulation resistance between the grounding prong and each one of the two power prongs.

When connection wires are used:

With the megohmmeter, measure the insulation resistance between the ground wire (Green) and each one of the two power wires.

Reference insulation resistance: 20MΩ or greater

Note: The reference insulation resistance (20MΩ or greater) is the value when the pump is new or has been repaired. For the reference value after installation, see Section 1.10 Maintenance and Inspection.

Precautions in Installation

WARNING

When installing the pump, pay close attention to its center of gravity and weight. If it is not lowered into place correctly, it may fall and be damaged or cause injury.

When transporting the pump by hand, be sure to employ manpower commensurate with the weight of the pump. To avoid back injury when lifting the pump, bend the knees to pick it up rather than bending your back only.

CAUTION

DO NOT under any circumstances install or move the pump by suspending it from the power cable. The cable may be damaged, causing electrical leakage, shock, or fire.

1. The pump is supplied with a threaded discharge fitting. Tighten hose coupling or discharge pipe securely and with proper gaskets.
2. Avoid dropping the pump or other strong impact. Lift the pump by holding it firmly with the hands or by attaching a rope or chain to the lifting handle.

Note: On power cable handling, see Section 1.7 Electrical Wiring.

CAUTION

Avoid dry operation, which will not only lower performance but can cause the pump to malfunction, leading to electrical leakage and shock.

3. Install the pump in a location with sufficient water level, where water collects readily.

Note: See Section 1.9 Operation (“Operating Water Level”) for the water level necessary for operation.

Note: The discharge end of the hose should be located higher than the water surface. If the end of the hose is submerged, water may flow back to the pump when the pump is stopped; and if the hose end is lower than the water surface, water may overflow when the pump is turned off.

CAUTION

If large quantities of earth are sucked up, damage resulting from friction in the pump can lead to electrical leakage and shock.

Maximum Allowable Water Pressure



ATTENTION: DO NOT use higher water pressure than the figure shown below. Maximum allowable water pressure: 28 PSI (0.2 MPa) discharge pressure used.

4. Use the pump in the upright position. To prevent the strainer from becoming submerged in mud, causing it to suck in sand or debris, mount it on a block or other firm base.
5. If used in a permanent installation, where the pump is not readily accessible after installation, please contact TSURUMI for a duplicate nameplate to be installed at the wellhead or on the control box so that it will be readily visible.

1.7 Electrical Wiring

Performing electrical wiring

! WARNING

Electrical wiring should be performed by a qualified person in accord with all applicable regulations. Failure to observe this precaution not only risks breaking the law but is extremely dangerous.

Incorrect wiring can lead to electrical leakage, electrical shock or fire.

ALWAYS make sure the pump is equipped with the specified overload protectors and fuses or breakers, so as to prevent electrical shock from an electrical leak or pump malfunction.

Operate within the capacity of the power supply and wiring.

Grounding

! WARNING

DO NOT use the pump without first grounding it properly. Failure to ground it can lead to electrical shock from an electrical leak or pump malfunction.

! CAUTION

DO NOT attach the grounding wire to a gas pipe, water pipe, lightning arrestor or telephone grounding wire. Improper grounding can result in electrical shock.

Connecting the power supply

! WARNING

Before connecting wires to the terminal, make certain the power supply is turned off (circuit breaker, etc.), to avoid electrical shock, shorting, or unexpected starting of the pump, leading to injury.

Before inserting the power supply plug, make certain the power supply is turned off (circuit breaker, etc.), to avoid electrical shock, shorting, or unexpected starting of the pump, leading to injury.

! CAUTION

DO NOT use the pump with the power cable or plug connected loosely, which can result in electric shock, shorting, or fire.

Draw power from a dedicated power outlet rated at 15A or above. Sharing the outlet with other equipment may cause overheating at the branch outlet and could result in fire.

- The three-prong grounded plug shall be connected as shown in the drawing.



ATTENTION: Be sure to use a dedicated power supply with a ground leakage circuit breaker.

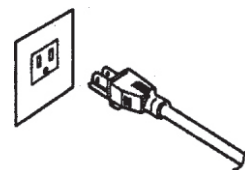

Note: The shape of the plug may differ from that shown in the illustration.

1.7 Electrical Wiring (cont.)

Power Cable

CAUTION

If it is necessary to extend the power cable, use a core size equal to or larger than the original. This is necessary not only for avoiding a performance drop, but to prevent cable overheating which can result in fire, electrical leakage or electrical shock.

If a cable with cut insulation or other damage is submerged in the water, there is a danger of damage to the pump, electrical leakage, electrical shock, or fire.

Be careful not to let the power cable be cut or become twisted. This may result in damage to the pump, electrical leakage, electrical shock, or fire.

If it is necessary to submerge the connection wires of the power cable in water, first seal the wires completely in a molded protective sleeve, to prevent electrical leakage, electrical shock, or fire.

DO NOT allow the power cable wires or power supply plug to become wet.

Make sure the cable does not become excessively bent or twisted, and does not rub against a structure in a way that might damage it.

If used in a deep-well installation the power cable should be secured every twenty feet.

1.8 Electrical Circuit Diagrams

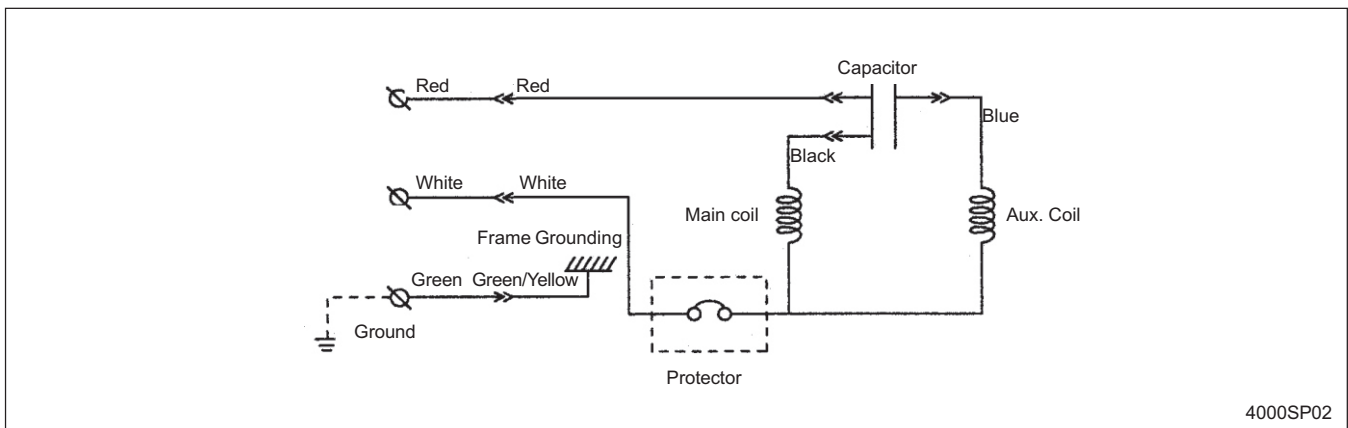

FIGURE 1.2 POWER SOURCE SINGLE PHASE

CAUTION

If connected to a circuit protected by a fuse, use a time-delay fuse with this pump.

1.9 Operation

Before starting

1. Make sure once again that the product is of the correct voltage and frequency rating.



ATTENTION: Using the product at other than rated voltage and frequency will not only lower its performance but may damage the product.

Note: Confirm the rated voltage and frequency on the model nameplate.

2. Confirm the wiring, supply voltage, circuit breaker capacity, and motor insulation resistance.

Reference insulation resistance = 20 MΩ or greater.

Note: The reference insulation resistance (20 MΩ or greater) is the value when the pump is new or has been repaired. For the reference value after installation see Section 1.10 Maintenance and Inspection.

3. The setting on the circuit breaker or other overload protector should be made in accord with the rated current of the pump.

Note: See Section 1.5 Standard Specifications for its rated current.

Test operation

WARNING

NEVER operate the pump while it is suspended in the air. The recoil may result in injury or other major accident.

CAUTION

NEVER start the pump when people are standing next to it. An electrical leak can result in electrical shock.

Run the pump for a short time (3–10 minutes) and confirm the following:

- Using an ammeter (clamp-on type), measure the operating current at the L1 and L2 phase wires on the terminal.



COUNTERMEASURE: If the operating current exceeds the rated value, pump motor overload may be a cause. Make sure the pump has been installed under proper conditions as described in Section 1.6 Installation.

- Using an AC voltmeter (tester), measure voltage at the terminals. Supply voltage and name plate voltage should match.



COUNTERMEASURE: If the supply voltage is outside the tolerance, possible causes are the power supply capacity or an inadequate extension cable. Look again at Section 1.7 Electrical Wiring and make sure the conditions are proper.

CAUTION

In case of very excessive vibration, unusual noise or odor, turn off the power immediately and consult with your nearest dealer or TSURUMI representative. Continuing to operate the pump under abnormal conditions may result in electrical shock, fire, or electrical leakage.

Operation

WARNING

The pump may become very hot during operation. Be careful not to contact the pump accidentally to avoid being burned.

Make sure no extraneous objects such as pins, nails or other metal objects are sucked into the pump. These can damage the pump or cause it to malfunction, and can result in electrical shock or electrical leakage.

When the pump is not used for an extended period, be sure to turn off the power (circuit breaker, etc.). Deterioration of the insulation may lead to electrical leakage, electrical shock, or fire.

In case of a power outage, turn off the power to the pump to avoid having it start unexpectedly when the power is restored, presenting serious danger to people in the vicinity.

TSURUMI PUMP

1.9 Operation (cont.)

Pay careful attention to the water level while the pump is operating. Dry operation may cause the pump to malfunction.

Note: See section below, *Operating water level*, for the water level necessary for operation.

Sharp bends in the hose, especially near its base, may cause air pockets to form resulting in idle operation. Lessen the degree of bending while continuing to operate the pump.

Operating water level

! CAUTION

DO NOT operate the pump below the C.W.L. (Continuous running Water Level) of 12-1/2" (315 mm) (min.). Failure to observe this condition may result in damage to the pump, electrical leakage or electrical shock.

Motor Protection System (Motor Protector)

The pump has a built-in motor protection system (Miniature Protector). If the motor overheats, for reasons such as the following, the pump will automatically stop operating regardless of the water level, to protect the motor:

- Change in supply voltage polarity
- Overload
- Open-phase operation or operation under constraint

Note: ALWAYS determine the cause of the problem and resolve it before resuming operation. Simply repeating cycles of stopping and restarting will result in damage to the pump. **DO NOT** continue operation at very low lift, low water level, or while the strainer is clogged with debris. Not only will performance suffer, but also such conditions may cause noise, heavy vibration, and malfunctioning.

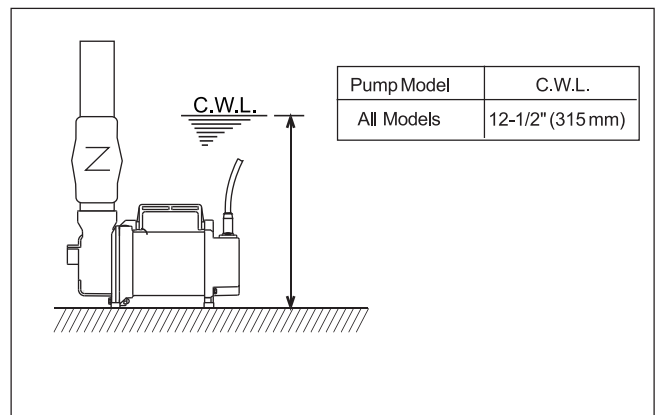

FIGURE 1.3

1.10 Maintenance and Inspection

Regular maintenance and inspections are a necessity for continued efficient functioning of the pump. If any abnormal conditions are noticed, refer to Section 1.12 *Troubleshooting* and take corrective measures immediately. It is recommended that a spare pump be kept ready in case of any problems.

Prior to inspecting

! WARNING

Detach the power cable from the receptacle or terminals, after making certain the power supply (circuit breaker, etc.) is turned off. Failure to follow this precaution may result in a serious accident from electrical shock or unexpected starting of the pump motor.

1. Washing the pump

Remove accumulated matter from the surface of the pump and wash it with clean water. Take special care to remove any debris from the impeller.

2. Inspecting the pump exterior

Look for any cracked or broken parts, and make sure the nuts and bolts are fastened tightly. Any cracked or broken parts should be replaced immediately.

Note: *Please consult with your nearest dealer or TSURUMI representative regarding repairs.*

1.10 Maintenance and Inspection (cont.)

Regular inspection

	Monthly	Semi-annually	Annually	Every 2 to 5 years
Measure insulation resistance. Reference insulation resistance = 1M Ω or greater. ¹	●			
Measure operating current. Compare with rated current.	●			
Measure supply voltage. Compare voltage to confirm it matches Name Plate voltage.	●			
Pump inspection. A noticeable drop in performance may indicate wear in the impeller, etc., or else clogging of the strainer, etc. Remove the clogged debris and replace any worn parts.	●			
Lubricant inspection. Check the lubricant every six months or after 1,500 hours of use, whichever comes first.		●		
Change lubricant. Change the lubricant every 12 months or after 3,000 hours of use, whichever comes first.			●	
Designated lubricant: White Mineral Oil ISO VG32 Lubricant capacity: See page 1-12			●	
Change mechanical seal. ³			●	
Overhaul. This should be carried out even if there are no problems with the pump. The frequency depends on how continuously the pump is in use. ⁴				●

¹ If the insulation resistance has become noticeably lower than the previous inspection, an inspection of the motor will be necessary.

² See Lubricant Inspection and Lubricant Change in this section.

³ Specialized know-how is required for inspecting and replacing the mechanical seal. Consult with your nearest dealer or TSURUMI representative. Note: If water is not found in the oil during the inspection of the oil as outlined above mechanical seal replacement is not necessary, until water is found in the oil.

⁴ Consult with your nearest dealer or TSURUMI representative regarding overhauls.

1.10 Maintenance and Inspection (cont.)

Storage

When the pump is out of use for an extended period, wash it and dry it thoroughly, then store it indoors.

Note: ALWAYS run a test operation before putting the pump back into service.

If the pump is left in the water, it should be run a minimum of once a week.

Lubricant Inspection and Lubricant Change

- Inspecting Lubricant
Remove the Oil Plug (Phillips Head Bolt) and tilt the pump to drain a small amount of lubricant. If the lubricant is milky white or has water mixed in with it, the mechanical seal may be faulty. In this case the pump will need to be disassembled and repaired.
- Replacing Lubricant
Remove the Oil Plug and drain all the lubricant, then replace it with the specified amount.

Note: Worn lubricant and other waste products should be disposed of by a qualified agent, in accord with applicable laws. The oil plug gasket should be replaced each time the lubricant is inspected or changed.

Replacement Parts

The table lists the parts that need to be replaced periodically. Replace these using the recommended frequency as a guideline.

Part	Replacement Frequency
Mechanical seal	When lubricant in oil compartment becomes milky.
Lubricant (White Mineral Oil ISO VG32)	Every 3000 hours or 12 months, whichever comes first.
Gasket	Each time pump is disassembled or inspected.

Model	Lubricant Capacity
3-PL	5.1 fl. oz. (150 ml)
5-PL	8.1 fl. oz. (240 ml)
9-PL	8.1 fl. oz. (240 ml)

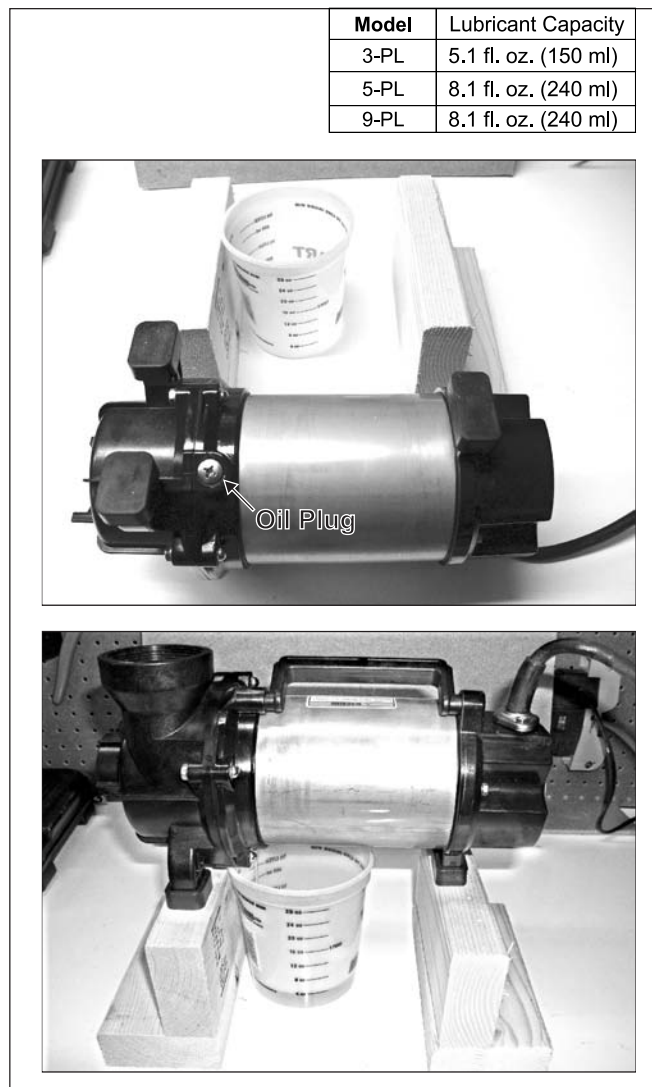

FIGURE 1.4

1.11 Disassembly and Reassembly

The procedure for disassembly and reassembly is shown here to the extent necessary for impeller replacement. A specialized environment and facilities are necessary for work on the mechanical seal and the motor parts. Contact your nearest dealer or TSURUMI representative in the event such repairs are necessary.

WARNING

Before disassembling the pump, first detach the power cable from the receptacle or terminals, after making certain the power supply (circuit breaker, etc.) is turned off. To avoid electrical shock, **DO NOT** work with wet hands.

NEVER check the operation of any parts (impeller rotation, etc.) by turning on the power while the unit is partially assembled. Failure to observe these precautions may result in a serious accident.

DO NOT disassemble or repair any parts other than those designated here. If repairs are necessary in any other than the designated parts, consult with your nearest dealer or TSURUMI representative. Improper repairs can result in electrical leakage, electrical shock, fire, or water leaks.

After reassembly, **ALWAYS** perform a test operation before resuming use of the pump. Improper assembly will cause the pump to malfunction, resulting in electric shock or water leaks.

1.11 Disassembly and Reassembly (cont.)

Disassembly

Note: For assembly or disassembly, place the pump upright on its feet.

1. Remove the casing bolts and nuts, then remove the pump casing.

Note: If the parts are worn or damaged, make sure to replace them with new ones.

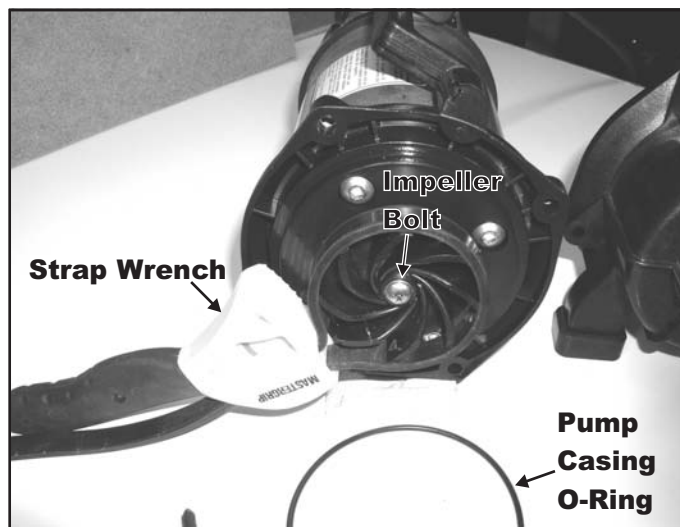
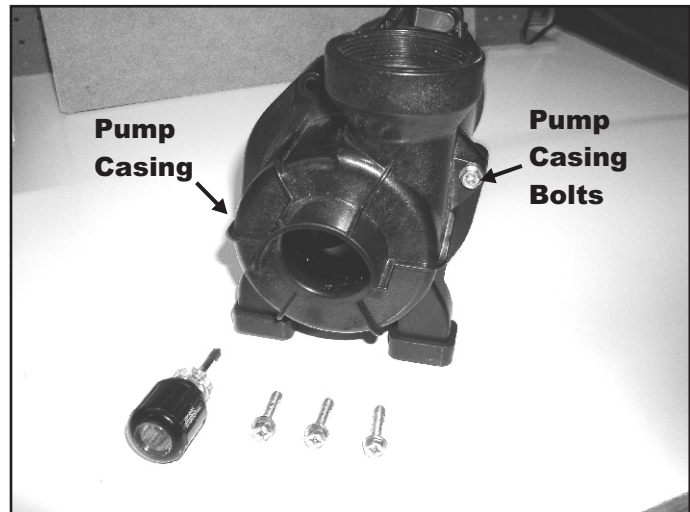

2. Remove the pump casing o-ring. Hold the impeller with a strap wrench and remove the impeller bolt.



ATTENTION: A worn impeller can have sharp edges; be careful to avoid injury.

Reassembly

Reassembly can be performed by reversing the steps for disassembly.

1. Remove sand and other debris from all parts such as the impeller and o-ring before assembling the pump.
2. Make sure the o-ring fits snugly against the oil housing.



1.12 Troubleshooting

Before ordering repairs, carefully read through this manual, then repeat the inspection. If the problem remains, contact your nearest dealer or TSURUMI representative.

 **WARNING**

ALWAYS turn off the power before inspecting the pump. Failure to observe this precaution can result in serious accident.

Problem	Possible Causes	Measures
Pump will not start	<ol style="list-style-type: none">1. Power is off.2. Power cable is cut or not connected properly.3. Impeller is clogged.	<ol style="list-style-type: none">1. Restore power.2. Repair/replace the cable or fix the connection.3. Inspect the pump and remove any debris.
Pump stops soon after starting (Motor protector operates)	<ol style="list-style-type: none">1. Impeller is clogged.2. Low voltage.3. Wrong power frequency.4. Extended operation with a clogged suction strainer.	<ol style="list-style-type: none">1. Remove debris.2. Provide the rated voltage, or make sure the power cable extension is the proper standard.3. Check the nameplate, and replace the pump or the impeller.4. Remove debris from the suction strainer.
Poor lift or discharge capacity	<ol style="list-style-type: none">1. Faulty motor.2. Excessive sand is discharged.3. Worn out impeller.4. Sharply bent or clogged hose.5. Suction strainer clogged or buried.	<ol style="list-style-type: none">1. Repair or replace the motor.2. Place the pump on a block or other base to prevent the sand from being sucked into it.3. Replace.4. Straighten out any sharp bends. Enclose the pump with a screen to keep away debris.5. Remove debris from the suction strainer, or place a block under the pump.
Heavy vibration or noise	<ol style="list-style-type: none">1. Damaged motor shaft.	<ol style="list-style-type: none">1. Contact dealer and replace motor.

Notes:

motralec

4 rue Lavoisier . ZA Lavoisier . 95223 HERBLAY CEDEX

Tel. : 01.39.97.65.10 / Fax. : 01.39.97.68.48

Demande de prix / e-mail : service-commercial@motralec.com

www.motralec.com