

**motralec**

4 rue Lavoisier . ZA Lavoisier . 95223 HERBLAY CEDEX  
Tel. : 01.39.97.65.10 / Fax. : 01.39.97.68.48  
Demande de prix / e-mail : [service-commercial@motralec.com](mailto:service-commercial@motralec.com)  
[www.motralec.com](http://www.motralec.com)

**SULZER**

## SJD Vertical Multistage Can Pumps for Condensate Extraction (CEP)

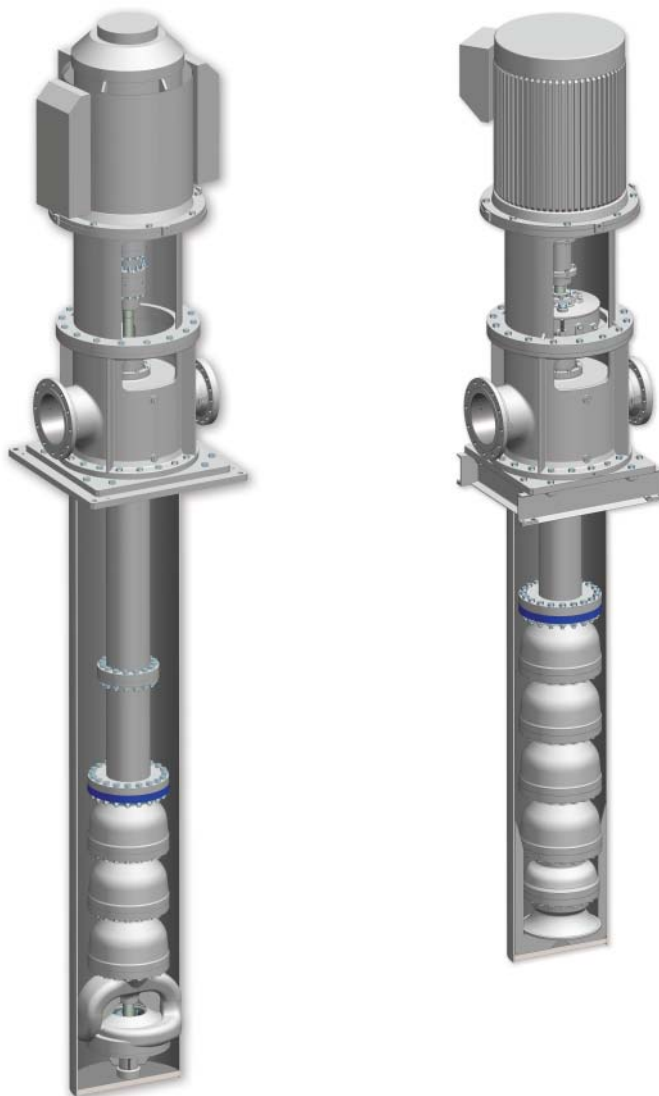

The **Heart**  
of Your  
Process

# Sulzer Pumps

Sulzer Pumps is a leading global supplier of reliable products and innovative pumping solutions for end users. Our active research and development, detailed process and application knowledge together with a comprehensive understanding of market demands keeps us consistently at the leading edge of technical development. Our global network of modern manufacturing and packaging facilities together with sales offices, service centers and representatives located close to major markets provide fast responses to customer needs.



## Extensive Product Range

Sulzer Pumps has a long history of providing innovative pumping solutions to business partners in the following industries:

- Oil & Gas
- Hydrocarbon Processing
- Pulp & Paper
- Power Generation
- Water & Wastewater
- Food, Metals & Fertilizers

### Vertical Canned Pumps

These pumps are used in many applications where the available NPSH is insufficient to allow the installation of more conventional pump types. NPSH requirements of the pump are met by simply adjusting the length of the pump and can. The advantage is minimal floor space usage. Because the pump typically operates within a suction can, ideal suction conditions are provided within the normal operating envelope. Vertical can pumps are typically used in power generation, oil and gas, hydrocarbon processing and general

industrial applications. Although commonly supplied with a suction can, SJD (CEP) pumps are also available without a can.

### Applications

Sulzer SJD (CEP) pumps are specified wherever limited NPSH is available, either due to system constraints or liquids operating near to their vapor pressure.

Typical uses include high temperature condensate extraction pumps in power generation plants, pumping liquefied gases as well as general refining and industrial applications. Installing a Sulzer SJD (CEP) pump makes certain reliable suction performance is maintained no matter how marginal the process conditions may seem.



## Design

The pump is a vertical, can mounted, multistage bowl diffuser pump with two designs:

- Single Suction First Stage Impeller designed for applications and typically used in 50 Hz combined cycle plants
- Double Suction First Stage Impeller designed for applications and typically used in 60 Hz coal fired plants

The impellers are closed type with replaceable wear surface. The hydraulic profiles are designed using

CFD technology which ensures high efficiency and reliable operation. The bowl is provided with replaceable, stationary wear rings and designed to incorporate product lubricated journal bearings. The top bowl is bolted to a column which depending on requirements may consist of one or more sections. The column pipe is fabricated to adapt the pump length. In every section of the column, the line shaft is supported by one intermediate product lubricated bearing.



## Designed for the Most Challenging Requirements

The axial thrust of the pump is taken up by antifriction bearings. Depending on customer requirements these bearings can be mounted either in the pump, on the suction and discharge head or in the driver. Suction and discharge head and suction can are designed to suit a variety of applications. Cast suction and discharge heads are standard (fabricated is optional) while the suction cans are always fabricated. Our standard is that the suction and discharge flanges are located above the grade level. The connecting flanges are in accordance with specified requirements. The shaft sealing is accomplished by means of cartridge type mechanical seals.



### Materials

Suction bell	cast iron, carbon steel, 12 % chrome steel
Bowl	cast iron, ductile iron, carbon steel and 12 % chrome steel
Suction impeller	12 % chrome steel
Series impeller	cast iron, 12 % chrome steel
Wear rings	cast iron, 12 % chrome steel with heat treatment
Shaft and intermediate couplings	416 stainless steel
Journal bearings	carbon
Suction and discharge head	ductile iron, fabricated steel
Can	fabricated steel

# SJD (CEP) 50 Hz Design Features and Benefits

## Separate Fabricated Driver Stand

Allows use of one suction and discharge head per pump size— independent of motor frame or coupling spacer lengths.

## Shaft Sealing

Accomplished by dual mechanical (back-to-back) cartridge seal. Removable seal housing allows servicing throttle bushing without removing the head.

## Cast Suction and Discharge Head

Designed with 150# suction flange and 300# discharge flange as standard. Fabricated version available.

## Flanged Fabricated Column Pipes

Designed with bolted joint flange and sealed o-ring. Provide adequate sealing without overstressing the bolts.

## Bearing Bushings

Product lubricated bearings are carbon graphite. Provide for long maintenance- free periods; located in all bearing spiders and bowls.

## First Stage Single Suction Impeller

Provides high suction specific speed with a low and flat NPSHr curve. This overhung impeller provides high first stage head.

## Dual Wear Ring Surface

Provides replaceable wear surface for all impellers and bowls.

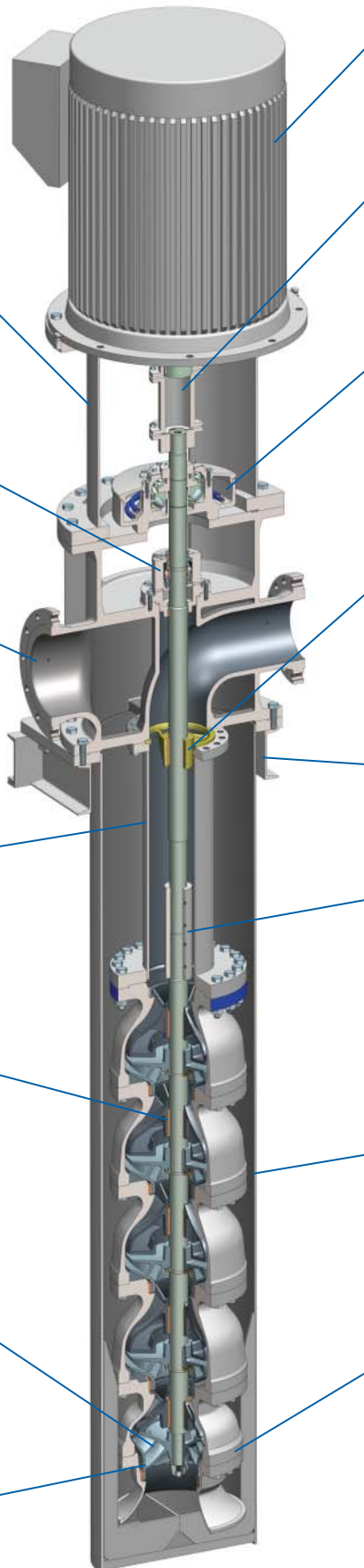

**Vertical Solid Shaft Motor**  
Without thrust bearing IEC “C” Base.

## Flexible Coupling with Spacer

Allows servicing the thrust bearing and mechanical seal as needed.

## Axial Thrust Bearing

Located in the pump (on suction and discharge head), sized to handle the axial thrust during start-up and normal operation.

## Drop-In Bearing Spider

Designed with an offset to allow re-use of the same shaft by flipping the spider over.

**Fabricated Baseplate**  
is optional.

## Sleeve Intermediate Coupling

(Thrust stud) designed for larger shaft diameters above 68 mm. For smaller sizes threaded intermediate coupling is available.

## Fabricated Can

Has bottom and lateral anti-rotation ribs; provides uniform and adequate velocity flow downstream along the can length.

## Bowl Assembly

Bolted joint flange and o-ring sealed bowls.

# SJD (CEP) 60 Hz Design Features and Benefits

## Separate Fabricated Driver Stand

Allows use of one suction and discharge head per pump size— independent of motor frame or coupling spacer lengths.

## Shaft Sealing

Accomplished by single mechanical cartridge seal. Removable seal housing allows servicing the throttle bushing without removing the head.

## Cast Suction and Discharge Head

Designed with 150# suction flange and 300#/400# discharge flange as standard execution. Fabricated version available.

## Drop-In Bearing Spider

Designed with an offset to allow re-use of the same shaft by flipping the spider over. Fabricated welded-in version available.

## Bearing Bushings

Product lubricated bearings are carbon graphite. Provide for long maintenance- free periods; located in all bearing spiders and bowls.

## First Stage Double Suction Impeller

Provides low suction specific speed,  $NSS \leq 11,000$  with adequate NPSHr curve. This impeller is a between bearing design. It provides high head for first stage.

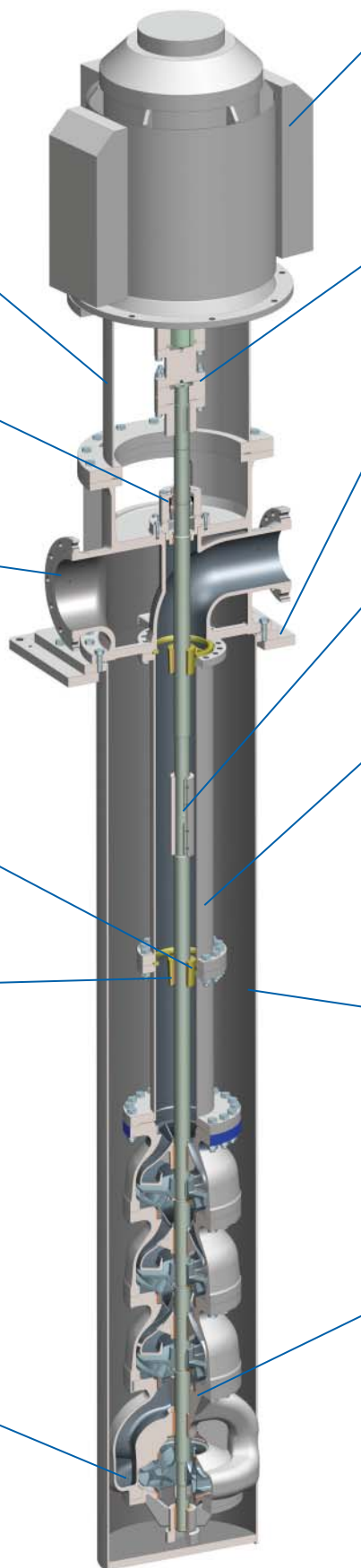

## Vertical Solid Shaft Motor

Designed with thrust bearing and sized by motor manufacturer to handle the axial thrust; NEMA "P" base.

## Rigid (Flanged Adjustable) Coupling

Designed with spacer to allow servicing of mechanical seals as needed.

Baseplate is optional.

## Sleeve Intermediate Coupling

(Thrust stud) designed for all diameters.

## Flanged Fabricated Column Pipes

Designed with bolted joint flange and sealed o-ring. Provide adequate sealing without overstressing the bolts.

## Fabricated Can

Designed without anti-rotation ribs; provides uniform and adequate velocity flow downstream along the can length; swirl is avoided by the volute case outer contour and ribs in the suction bell.

## Dual Wear Ring Surface

Provides replaceable wear surface for all impellers, bowls and volute case.

# SJD (CEP) Performance Ranges

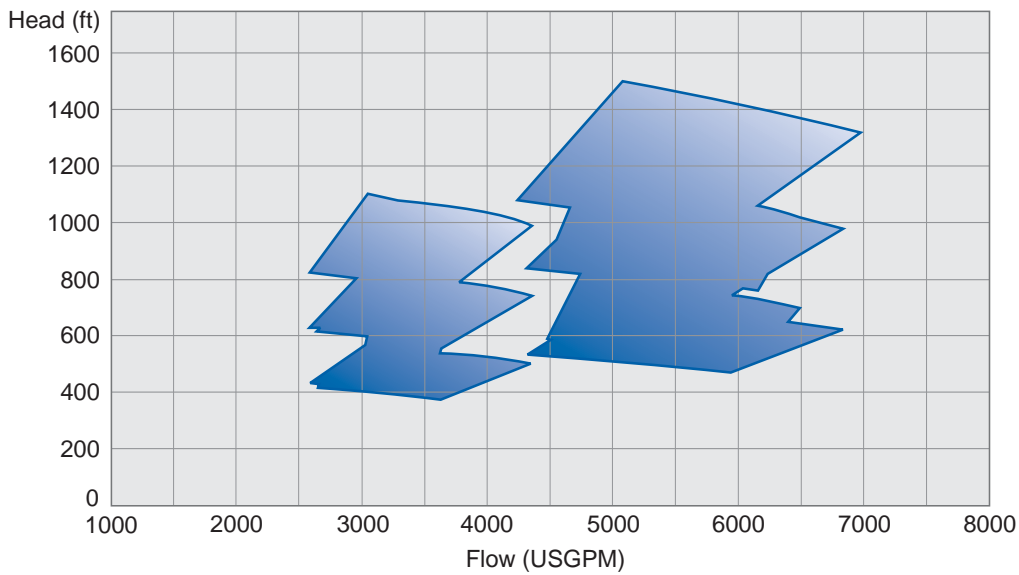
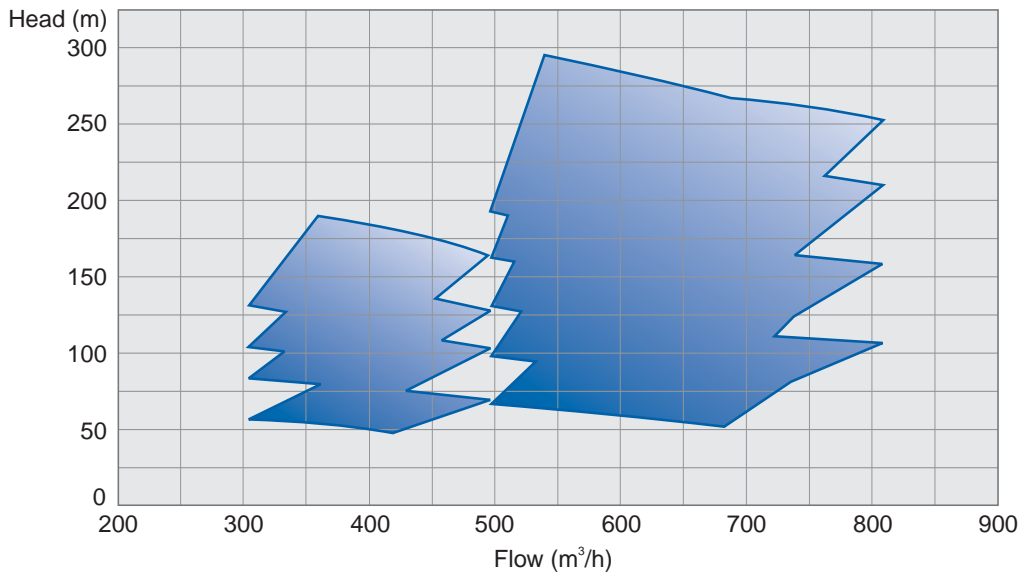

## Operating Data

	SJD (CEP) 50 Hz	SJD (CEP) 60 Hz
Capacities	300 to 800 m³/h	2,750 to 7,000 USgpm
Heads	up to 280 m	up to 1,400 feet
Suction pressures	up to 4 bar	up to 58 psi
Max operating pressures	up to 43 bar	up to 680 psi
Temperatures	0° C to 100° C	32° F to 212° F

# Sulzer Pumps Customer Support Services

If pumps and rotating equipment are critical to your operations, you seek specific qualities when selecting external service support:

- A service partner you can trust
- Reliability
- Responsiveness
- Rapid turn around
- Innovative Solutions

Our service professionals deliver these qualities and more to customers from all industry sectors around the globe. With services ranging from spare parts to trouble shooting, we can maintain your rotating equipment and improve your processes.

## Service Partner

Our goal is to be your business partner who delivers customized service solutions that improve your operations. Our measure of success is the loyalty of our customers year after year, decade after decade.

## Reliability

Reliability depends on the longevity of replacement parts and the quality of repair of damaged or worn equipment. You can count on our expertise to deliver and on our commitment to do the job right first time every time.

Our teams are known in the industry for their extreme dedication.

You can rely on us to stand by you if unexpected problems occur.

## Responsiveness

You have specific needs, expectations and priorities – we are responsive to them and define with you the best possible solutions for your business. You need us urgently? We are present 24/7, 365 days per year.

## Rapid Turn-around

You expect to receive quotations quickly and have your equipment repaired rapidly to minimize disruption and costs. We aim to exceed your expectations through our continuous investment in more effective shopfloor and administrative processes.

## Innovative Solutions

Sulzer Pumps is renowned in the industry for its innovative technology and application know-how. We are able to make the best evaluation of your installation and optimize its performance. We can achieve increased throughput, lift efficiency and improve reliability in most pumps by replacing existing hydraulics with state of the art Sulzer Pumps designs.



Performance Through People

**SULZER**

**motralec**

4 rue Lavoisier . ZA Lavoisier . 95223 HERBLAY CEDEX  
Tel. : 01.39.97.65.10 / Fax. : 01.39.97.68.48  
Demande de prix / e-mail : [service-commercial@motralec.com](mailto:service-commercial@motralec.com)

[www.motralec.com](http://www.motralec.com)