

SULZER



Sulzer Pumps for Phosphoric Acid Applications

motralec

4 rue Lavoisier . ZA Lavoisier . 95223 HERBLAY CEDEX

Tel. : 01.39.97.65.10 / Fax. : 01.39.97.68.48

Demande de prix / e-mail : service-commercial@motralec.com

www.motralec.com

The Heart
of Your
Process





Sulzer Pumps – Know-how in fertilizer pump applications

**Expertise
to meet your
present and
future needs.**

Sulzer Pumps

Sulzer Pumps is a leading global supplier of reliable products and innovative pumping solutions for end users. Our active research and development, detailed process and application knowledge together with a comprehensive understanding of

market demands keeps us consistently at the leading edge of technical development. Our global network of modern manufacturing and packaging facilities together with sales offices, service centers and representatives located close to major markets provide fast responses to customer needs.

Sulzer Pumps is active serving business partners in the following industries:

- Oil & Gas
- Hydrocarbon Processing
- Pulp & Paper
- Power Generation
- Food, Metals & Fertilizers
- Water & Wastewater

**Recognition
of our
customers'
needs and
requirements.**

Process know-how

Sulzer Pumps' expertise in the fertilizer industry has been acquired through long experience and recognition of our customers' needs and requirements. We offer a range of process pumps, special pumps, mixers and agitators for the production of nitrogen, phosphatic and potassium fertilizers. By working in close co-operation with our customers, and by getting fully involved in the intricacies of the processes we are able to select and provide the right solutions. By this we mean not only the right pump, but also the most suitable pump material, the correct seals, efficiency ratio and everything to ensure long working-life and reliability.

**Special
materials
for difficult
applications.**

Total production facilities

Sulzer Pumps has its own foundries giving us the capacity to develop and manufacture a range of different materials for protection against corrosion and wear. We specialize in producing different grades of corrosion-resistant cast steels, martensitic, austenitic and duplex. Our newest material, austenitic cast steel Avesta 654SMO* demonstrates the high technical competence of our foundries. We also have the ability to manufacture pumps from special materials such as titanium and Hastelloy.

*) Avesta 654 SMO is a trade mark owned by Outokumpu Stainless which has granted Sulzer Pumps Finland Oy licence to produce this material.



Sulzer Pumps at your service

AHLSTAR™ APP/APT process pumps

For all the normal pumping applications in the process industry.

Capabilities

- to 160 m head
- to 2000 l/s capacity
- to 180 °C temperature

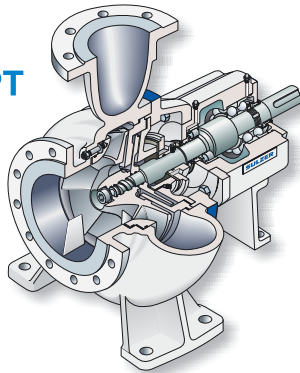

AHLSTAR™ ASP/AST self-priming gas removal pumps

Designed for continuous operation in industrial processes to pump gas-containing liquids up to 70% or when self-priming pumps are needed.

Capabilities

- to 160 m head
- to 1300 l/s capacity
- to 180 °C temperature

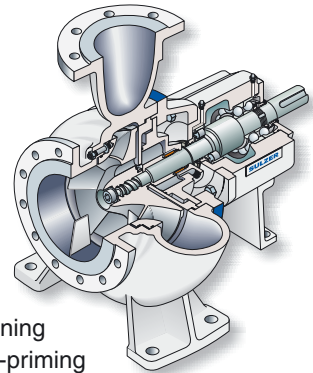

AHLSTAR™ WSP/WST wear resistant self-priming gas removal pumps

Enable trouble free pumping of corrosive and abrasive liquids containing gas up to 70 % or when self-priming pumps are needed.

Capabilities

- to 110 m head
- to 2000 l/s capacity
- to 180 °C temperature

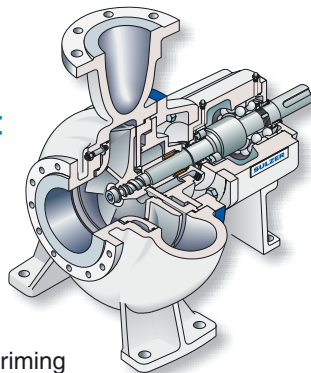

AHLSTAR™ WPP/WPT wear resistant pumps

Designed for corrosive and abrasive applications where durability is essential.

Capabilities

- to 110 m head
- to 2000 l/s capacity
- to 180 °C temperature

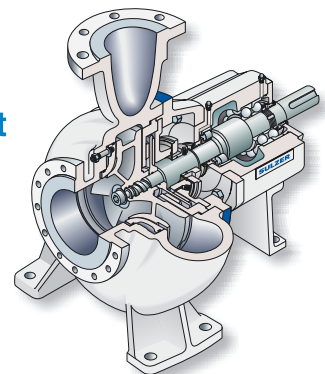



ADVANTAGE CPT chemical process pumps

Designed according to ANSI/ASME B73. 1 M standards for normal pumping applications for clean, abrasive or corrosive liquids and also for liquids containing fibers.

Capabilities

- to 170 m head
- to 280 l/s capacity
- to 180 °C temperature

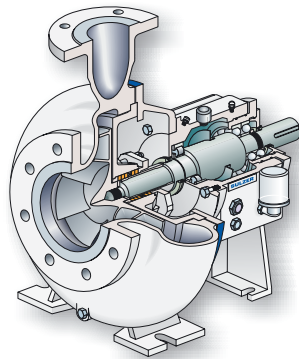

HPP/HPT multistage pumps

Designed for high pressure applications. Equipped with a silicon carbide balance drum / slide bearing.

Capabilities

- to 900 m head
- to 100 l/s capacity
- to 200 °C temperature

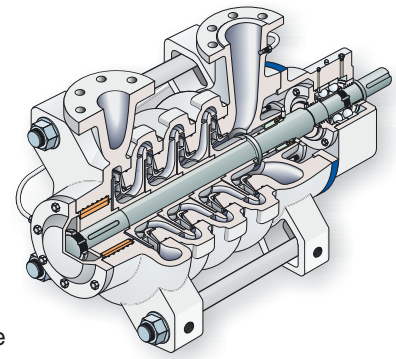

SALOMIX™ L-series top-mounted agitators

- with gear or belt drive
- impeller type and size is selected always according to the agitation need
- power range 0,5 kW - 450 kW
- shaft lengths up to 25 m
- impeller diameters 300 mm - 7200 mm
- special glide ring shaft seals for high pressures and temperatures
- wear resistant SiC bottom support for abrasive circumstances

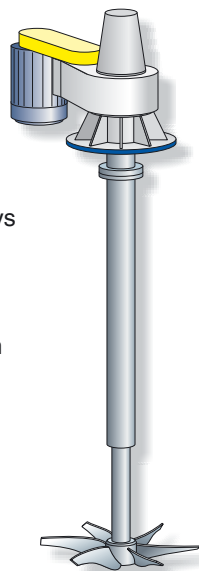

Other utilities

We also supply pumps for applications in water transport, mine dewatering, boiler feed and API 610 standard.



Competitive pumps for every process step

Reaction

Phosphoric acid slurries

AHLSTAR™ WPP/WPT wear and corrosion resistant process pumps

- open, wear and corrosion resistant impeller
- corrosion and wear resistant stainless steel material Avesta 654 SMO (4U)
- ready fitted double mechanical seal or unique dynamic shaft seal

SALOMIX™ L agitators

- versatile gear drive
- high axial flow paddle
- different seal options
- applicable stainless steels

Filtration

Filtrated phosphoric acids and circulation washing waters

AHLSTAR™ APP/APT process pumps or ADVANTAGE CPT chemical process pumps

- closed, high efficiency and low NPSHr impeller
- corrosion and wear resistant stainless steel material Avesta 654 SMO (4U)
- unique dynamic shaft seal

High pressure washing waters

HPP/HPT multistage pumps

- closed, high efficiency impeller
- corrosion and wear resistant material ASTM A890 3A (41)
- unique dynamic shaft seal

Evaporation

Phosphoric acid and circulation waters

AHLSTAR™ APP/APT process pumps or ADVANTAGE CPT chemical process pumps

- closed, high efficiency and low NPSHr impeller
- corrosion and wear resistant stainless steel material Avesta 654 SMO (4U)
- double mechanical seal or unique dynamic shaft seal

Purification

Phosphoric acids, pressure and washing waters

AHLSTAR™ APP/APT process pumps or ADVANTAGE CPT chemical process pumps

- closed, high efficiency and low NPSHr impeller
- corrosion and wear resistant stainless steel material Avesta 654 SMO (4U)
- unique dynamic shaft seal

Limed solutions and other liquids containing solid particles

AHLSTAR™ WPP/WPT wear and corrosion resistant process pumps

- open, wear and corrosion resistant impeller
- corrosion and wear resistant stainless steel material Avesta 654 SMO (4U)
- unique dynamic shaft seal

High pressure waters

HPP/HPT multistage pumps

- closed, high efficiency impeller
- corrosion and wear resistant material ASTM A890 3A (41)
- unique dynamic shaft seal



Gas scrubbing

Corrosive circulation water of the scrubber

AHLSTAR™ APP/APT process pumps or ADVANTAGE CPT chemical process pumps

- closed, high efficiency and low NPSHr impeller
- corrosion and wear resistant stainless steel material Avesta 654 SMO (4U)
- unique dynamic shaft seal

Waste water treatment

Lime neutralized waste waters and for clarifier underflow

AHLSTAR™ WPP/WPT wear and corrosion resistant process pumps

- open, wear and corrosion resistant impeller
- corrosion and wear resistant stainless steel material ASTM A890 1B (4L)
- unique dynamic shaft seal

Waste water feed from the waste basin

AHLSTAR™ ASP/AST self priming process pumps or WSP/WST wear resistant self priming process pumps

- open impeller
- corrosion and wear resistant stainless steel material ASTM A890 1B (4L)
- integrated vacuum structure

Treated and filtrated waters

AHLSTAR™ APP/APT process pumps or ADVANTAGE CPT chemical process pumps

- closed, high efficiency and low NPSHr impeller
- corrosion and wear resistant stainless steel material ASTM A890 1B (4L)
- unique dynamic shaft seal

Other utilities

Water transport

The B series of vertical line shaft pumps consist of BK, BS and BP ranges. They are primarily used in water lift, transfer and cooling water applications.

AHLSTAR™ NKP/NKT non-clogging and WKP/WKT wear resistant vertical cantilever pumps are used in applications with liquids containing solids or abrasive slurries and when no support bearing inside the liquid is allowed.

AHLSTAR™ NVP/NVT non-clogging vertical pumps are intended for all kinds of hard applications with waste water, slurries or waste stock.

SM/SMN single stage double entry pumps are used across a broad range of industries in liquid transport and transfer applications.

ZPP double suction pumps are designed for applications including cooling and circulating water pumping.

Mine dewatering

The HPH/HPL multistage pumps are specifically designed for mine dewatering applications. Their robust construction is designed to combat the highly abrasive environment in which they operate.

Nitrogen fertilizers

The Z series of end suction process pumps are available in both industrial and API 610 OH2 versions. In addition the ZU is available as a hot water boiler circulating pump.

Boiler feed

The M series of ring section multistage pumps consist of MB, MC, MD and ME ranges. A wide range of common hydraulic components and bearing assemblies are used within the 4 standard pressure ranges.



Maintaining and improving pump performance

Sulzer Pumps – Customer Support Service

The continuous availability and high operating performance of pumps is the key target for our customer support service organization. Through our highly experienced personnel and application knowledge, we provide a full range of innovative service solutions to our customers to keep their pumps running including;

- Spare Parts
- Field Service
- Repair Services
- Retrofits
- Maintenance Agreements
- Operation Agreements

Flexibility

With services ranging in scope from supplying a spare part to operating the pump under contract, we are uniquely placed to make your process run smoother. A dedicated team of CSS specialists based at either our manufacturing facilities or one of over 50 service centers located around the world is dedicated to maintaining the performance of our customers pumps and associated equipment. This service is not just limited to Sulzer products, all the pumps our customers operate can benefit from the support of Sulzer CSS specialists.

Network of Locations

- Divisional Headquarters
- Manufacturing Facility
- Customer Support Service Center (CSS)
- Sales Office



SULZER

motralec

4 rue Lavoisier . ZA Lavoisier . 95223 HERBLAY CEDEX
Tel. : 01.39.97.65.10 / Fax. : 01.39.97.68.48
Demande de prix / e-mail : service-commercial@motralec.com
www.motralec.com