

HZB Double Suction Volute Pumps

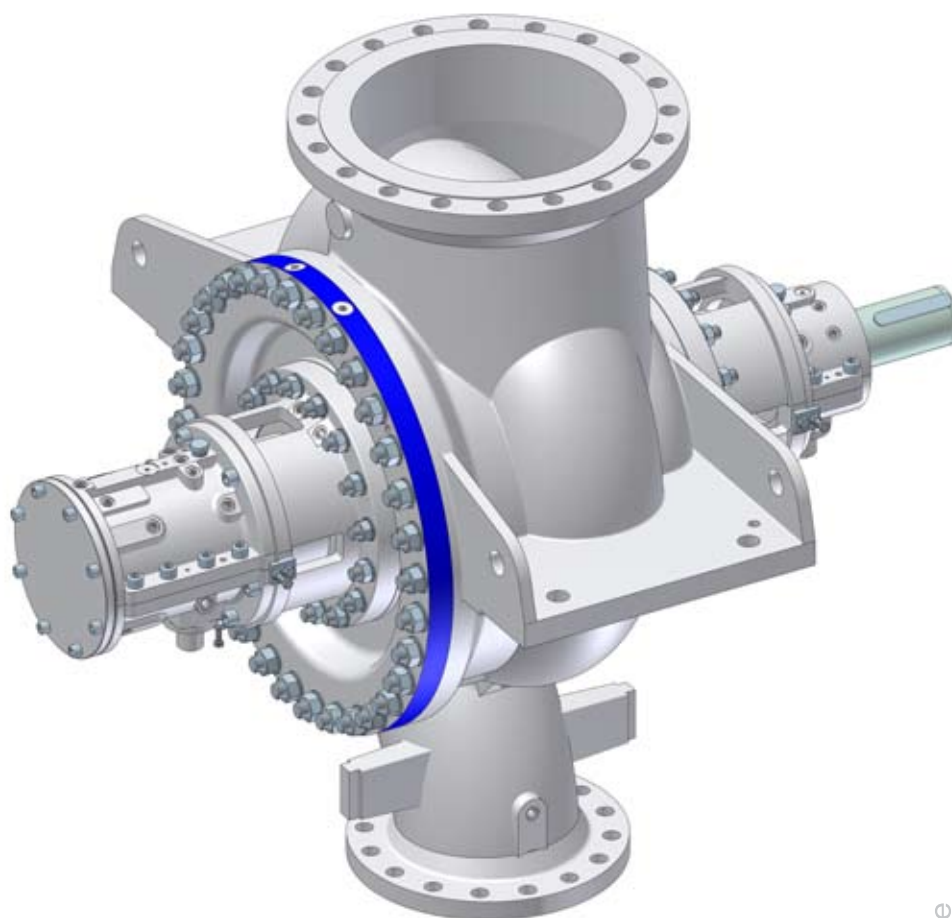

motralec

4 rue Lavoisier . ZA Lavoisier . 95223 HERBLAY CEDEX
Tel. : 01.39.97.65.10 / Fax. : 01.39.97.68.48
Demande de prix / e-mail : service-commercial@motralec.com

www.motralec.com

The Heart
of Your
Process

Sulzer Pumps

Sulzer Pumps has been designing and building pumps since 1834. Today the company is recognized the world over for the quality and reliability of its products. Our active research and development supports this customer oriented approach.

Sulzer Pumps has sales and service facilities in all the major markets of the world to provide fast and flexible response and support. This specialization has allowed us to build a complete understanding of the processes our pumps are used in, leading to more efficient and reliable products.



Extensive Knowledge in Products and Processes

Our detailed process and application knowledge has allowed us to develop innovative pumping solutions for our focus segments:

- Oil & Gas
- Hydrocarbon Processing
- Pulp & Paper
- Power Generation
- Food, Metals & Fertilizers
- Water & Wastewater

Sulzer Pumps offers products for all types of power plants - nuclear reactor, fossil fired, geothermal, combined cycle, large and small industrial power plants.

We offer boiler feed pumps for subcritical and supercritical fossil fuel plants, cooling water pumps, condensate extraction pumps and pumps for auxiliary services.

Providing technical expertise in a broad spectrum of pumping applications benefits our customers.

Engineering and implementing reliable, cost effective pumping solutions to meet the demands of a continually evolving power generation industry is our focus.

We have a successful track record of improving our customers' profitability by setting new standards in efficiency and reliability. Millions of people around the world are benefiting from a more reliable power supply as a result.



Design

Sulzer HZB pumps are horizontal, single stage, double suction, centerline mounted pumps. They are designed for hot water applications with relatively low NPSH available, primarily as booster pump for large boiler feed water units in both conventional thermal and nuclear power stations. The rugged design ensures the long term reliable operation that is critical in its applications.

HZB pumps are designed to operate at temperatures up to 220° C (430° F) with a maximum working pressure of 48 bar (700 psi).



Proven Technology

HZB pumps can be designed as either top suction / bottom discharge or top suction / top discharge (50°) nozzle arrangement. Discharge heads are designed for 300# R.F. flange rating. Weld end transition pieces prepared for weld connections are optional. Centerline mounting of casing and a custom baseplate design are used to allow operation at high temperatures.

Double suction first stage impeller is provided for low NPSHr. The direction of rotation is clockwise. Material of construction for the pressure casing, impeller and shaft is chrome steel.

The pump design is optimized with reduced bearing span assuring stable dynamic behavior. Chrome Steel material allows high corrosion resistance for boiler feed services. The pump is suitable for cold start without pre-warming. High reliability and efficiency are key to the design and deliver trouble-free operation.

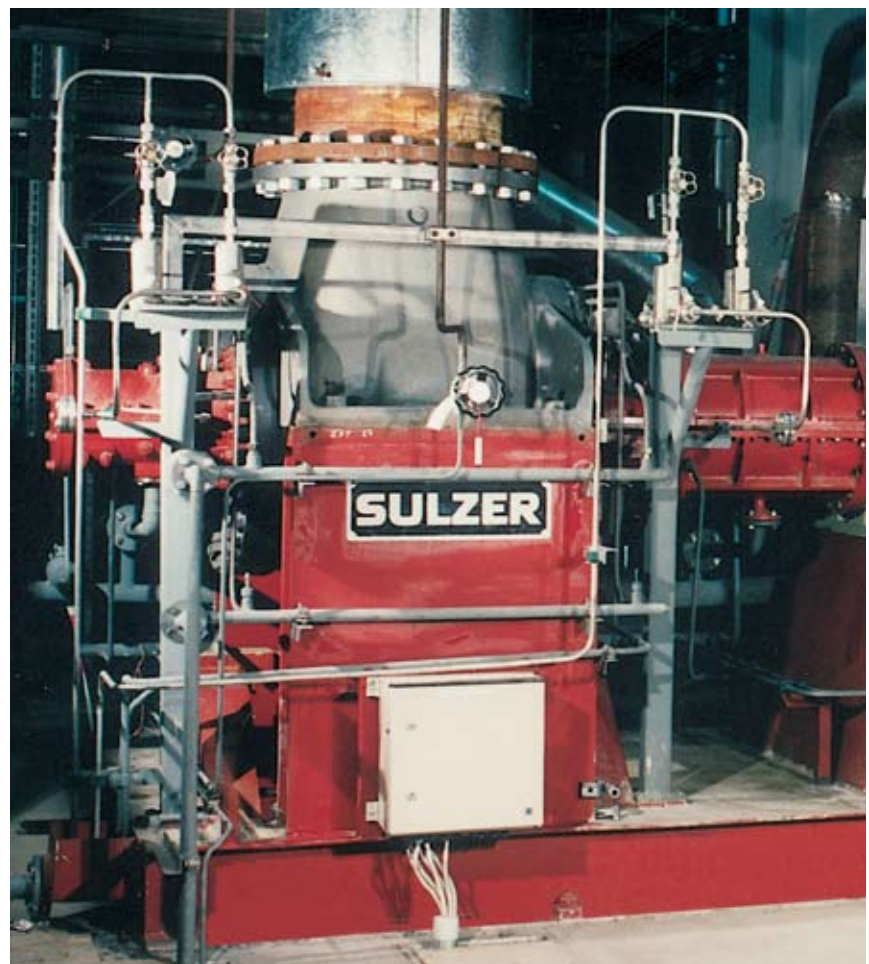

HZB Design Features and Benefits

Nozzle Arrangements

Top Suction / Bottom Discharge or Top Suction / Top Discharge (50°) nozzle arrangement.

Flange rating is ANSI 300#, transition pieces prepared for weld connections are optional.

Shaft Sealing

Single mechanical seal - API Plan 23 - with jacket cooling.

Bearings

Amply sized sleeve radial and tilting pad (pivot shoe) bearings with forced lubrication are standard. Optionally, self-contained ring oil lubricated bearings are available (sleeve radial and ball thrust bearings).

Replaceable Bearing Isolators

Replaceable, metallic bearing isolators are standard.

Chrome Steel Casing

Material of construction for pressure casing, impeller and shaft is chrome steel with good corrosion resistance and excellent mechanical properties.

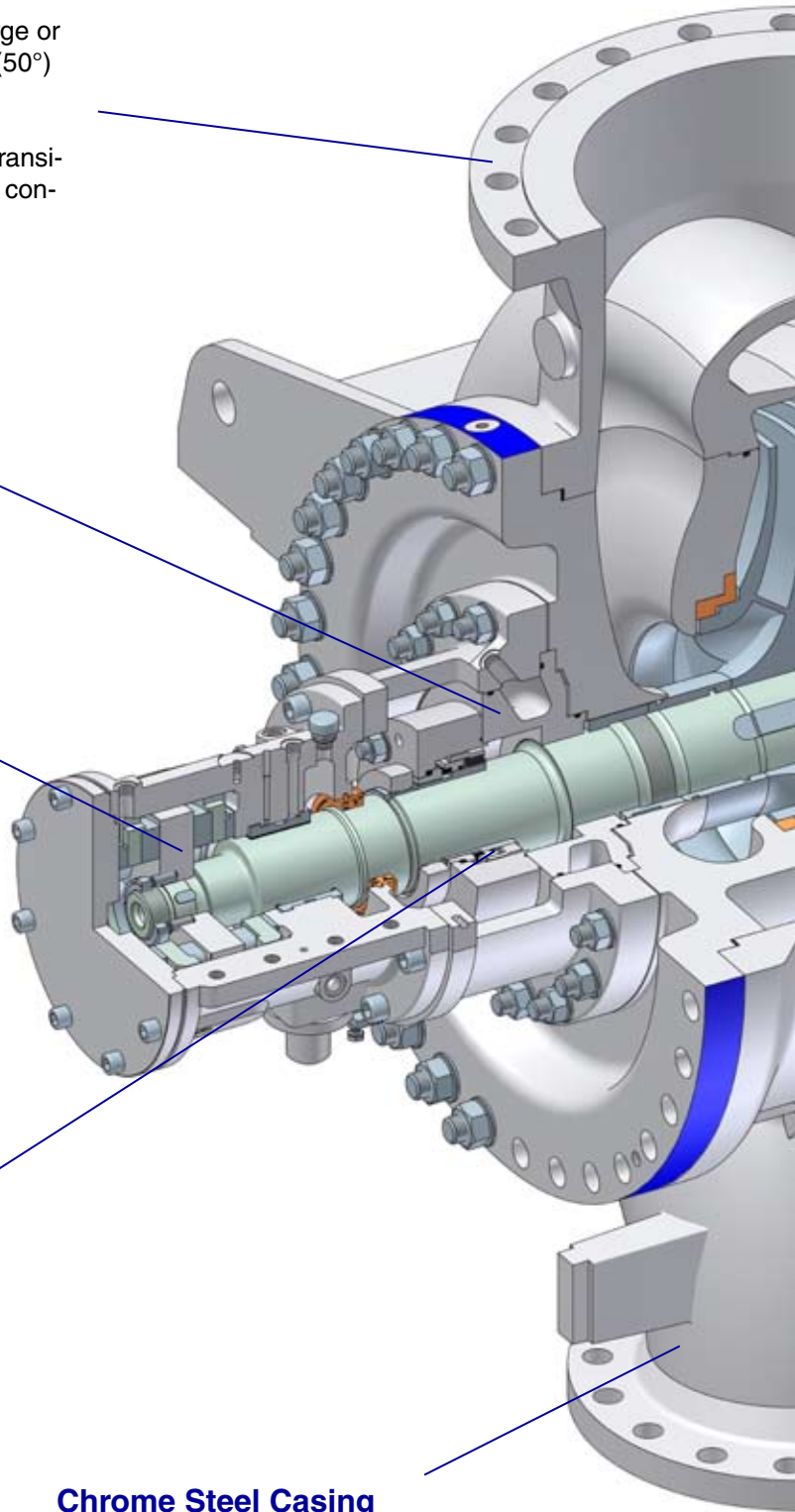

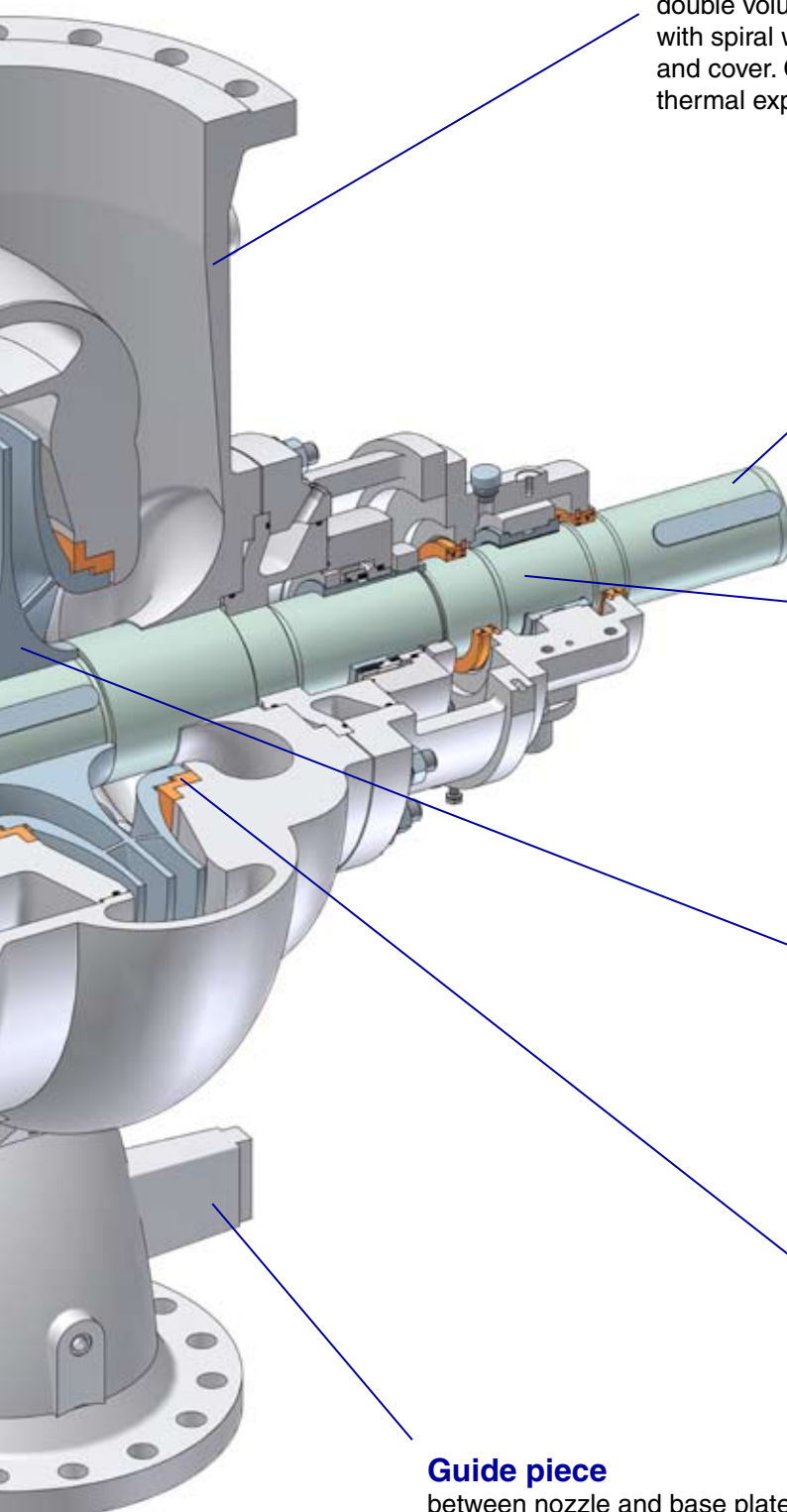

Casing

Cast pump casing with double suction and double volute, radially split at non-drive end with spiral wounded gasket between casing and cover. Centerline mounted to allow free thermal expansion and high nozzle loads.

Direction of Rotation

Direction of rotation is clockwise viewed from driver.

Shaft

A shaft with minimum bearing span is used to ensure that deflection is minimized at seal faces, wear rings and coupling. Stiff shaft design ensures the critical speed is a minimum of 20% above the maximum operating speed.

Impeller

Double suction impeller for low NPSHr, enclosed type and dynamically balanced. It is keyed to the shaft and positively positioned against a shaft shoulder.

Wear Rings

Replaceable wear rings are fitted to the casing and impeller. The casing wear rings are additionally secured set screws.

Guide piece

between nozzle and base plate to take over nozzle load.

HZB Optional Design Features and Benefits

Boiler Feed Pump

Complete unit with HZB booster pump, fluid coupling and gear box, HPT boiler feed pump

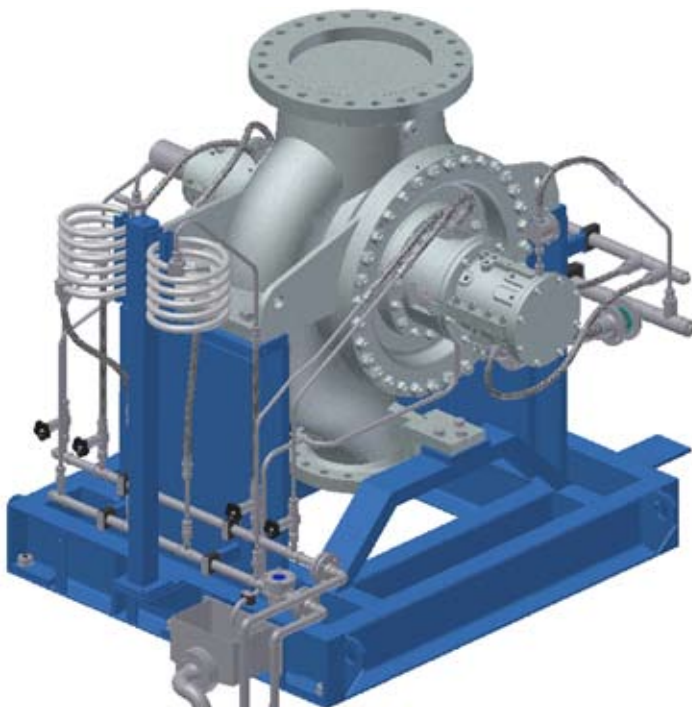
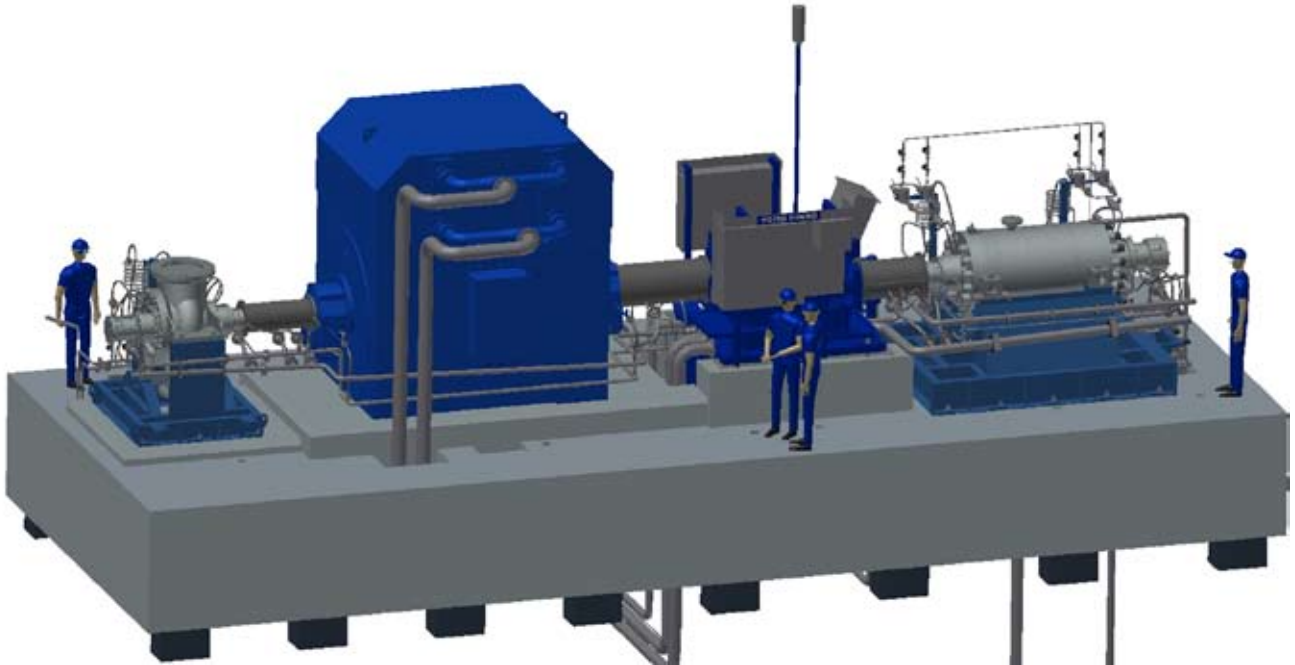

Typical arrangement of booster pump type HZB:

- Plan 23 for mechanical seal
- forced feed lubrication
- top - bottom nozzle arrangement with 300# flanges

Specific base plate design to allow safe operation at high temperatures and with two nozzle configuration (top-bottom / top-top). If required, common baseplate with booster and speed reducing gearbox is available.

Amply sized bolting and guide pieces between pump and base plate.

HZB Performance Ranges

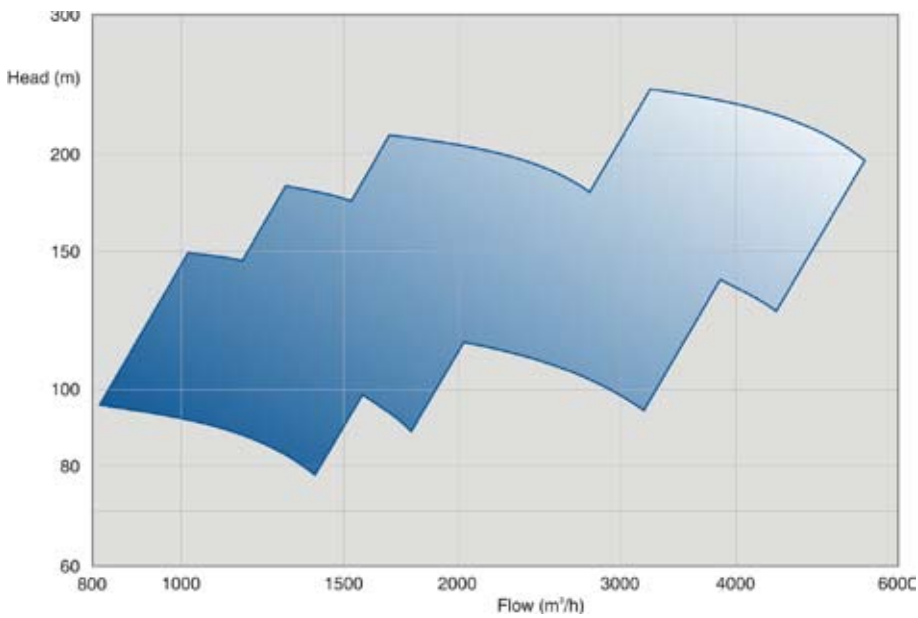

HZB 50 Hz

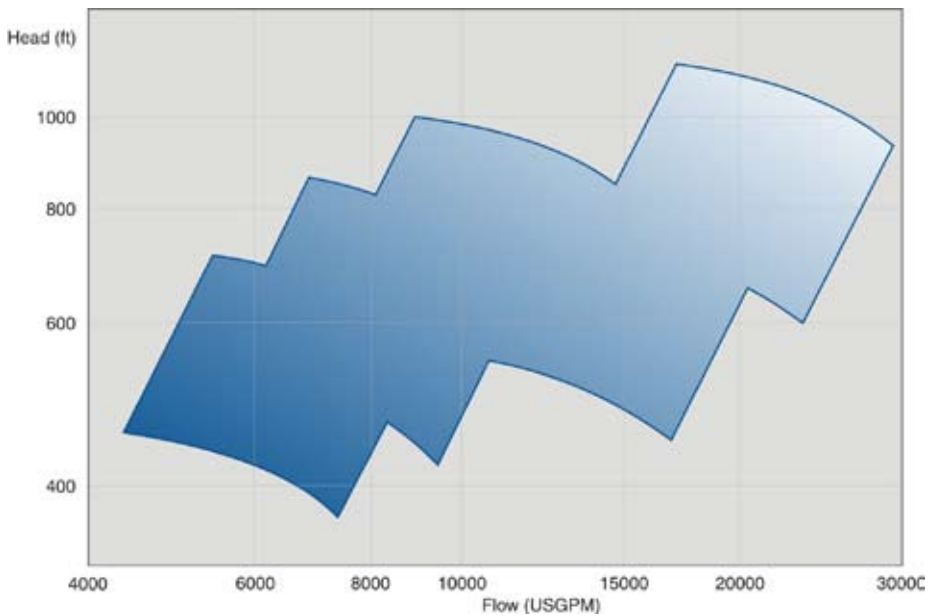

HZB 60 Hz

Operating Data

	HZB 50 Hz	HZB 60 Hz
Pump sizes	up to 600 mm	up to 24 inches
Capacities	up to 5,500 m ³ /h	up to 29,000 USgpm
Heads	up to 240 m	up to 1,100 feet
Pressures	up to 48 bar	up to 700 psi
Temperatures	up to 220° C	up to 430° F

SULZER

motralec

4 rue Lavoisier . ZA Lavoisier . 95223 HERBLAY CEDEX
Tel. : 01.39.97.65.10 / Fax. : 01.39.97.68.48
Demande de prix / e-mail : service-commercial@motralec.com
www.motralec.com