

Diesel-Hydraulic Driven Pumping Unit for Firefighting

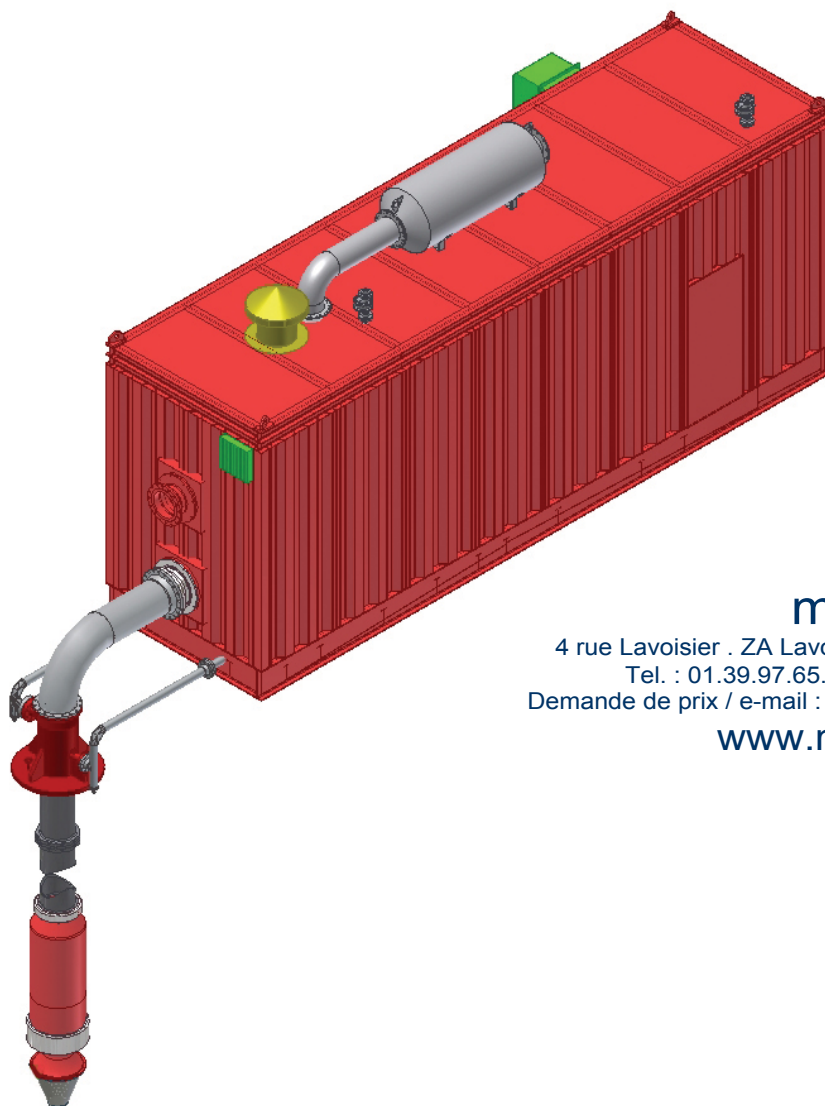

motralec

4 rue Lavoisier . ZA Lavoisier . 95223 HERBLAY CEDEX
Tel. : 01.39.97.65.10 / Fax. : 01.39.97.68.48
Demande de prix / e-mail : service-commercial@motralec.com
www.motralec.com

Description of the System

The Sulzer diesel-hydraulic driven pumping unit for offshore firefighting systems consists of a vertical lift pump driven by a hydraulic motor that lifts sea water to the booster pump. The booster is fitted inside a container mounted on the main deck which supplies sea water to the firefighting ring mains on the ship or platform.

The lift pump motor is driven by high pressure oil delivered by the hydraulic pumps installed in the container. The hydraulic pumps are driven by a diesel engine through a cardan shaft, the engine also drives the booster pump using a similar coupling arrangement.

The centrifugal pumps fully comply with the ISO 13709 (API610) requirements.

The system supplied by Sulzer Pumps runs completely autonomously. A complete hydraulic system to operate the lift pump is delivered within the container including:

- Hydraulic unit to run the lift pump at low speed
- Diesel engine
- Cooling system
- Fuel supply system for the diesel engine
- Electric and/or pneumatic start up system
- Batteries and battery chargers

- Electrical and hydraulic ventilation system
- Gas, heat, fire and smoke detection and controlling system
- CO₂ feed system and dampers.
- Complete operational control is performed by a PLC which is supplied with a customized control panel designed to meet the exact requirements of each customer.

The "marinized" diesel engine is designed to operate under the most extreme operating conditions up to 150% of the normal condition within the motion limits of the vessel. Apart from complying with NFPA 20 requirements, a com-

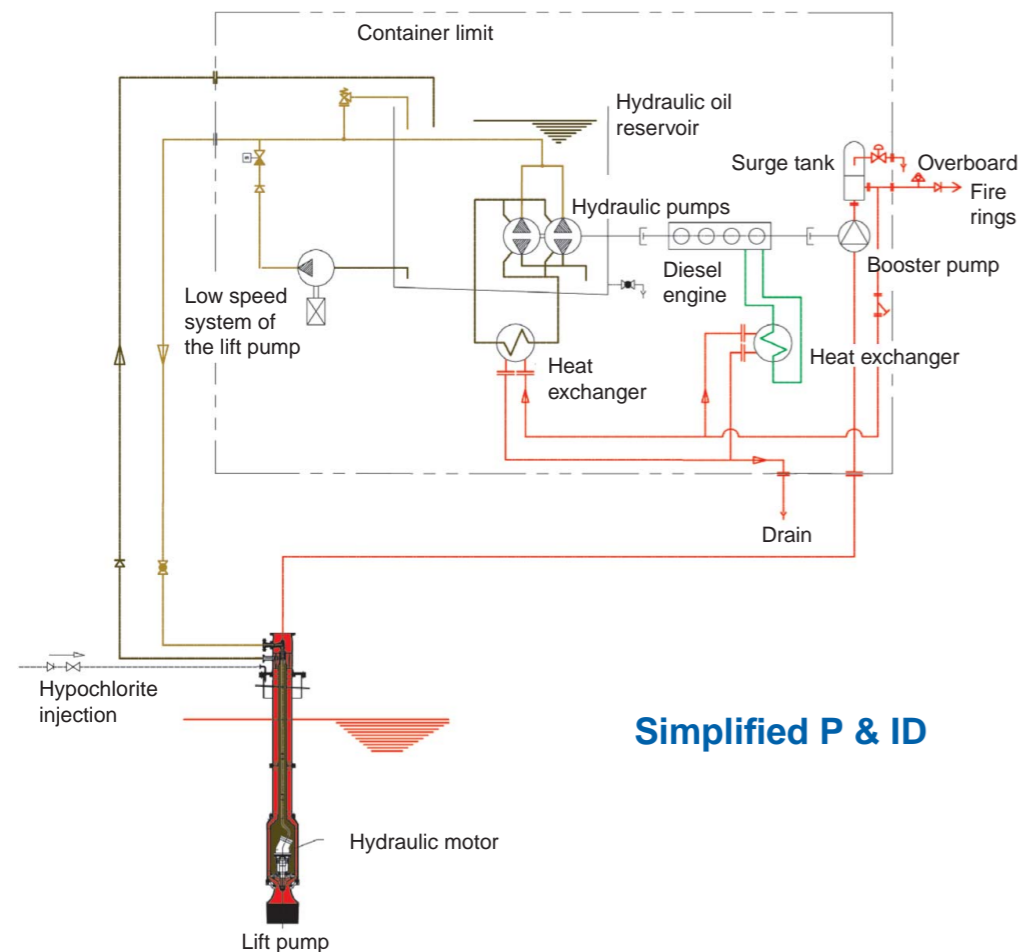

Simplified P & ID



plete torsional analysis of the train is made, delivering very low vibration levels for the unit. In addition to the project specific features, the engine is fitted on metallic anti-vibration mountings (AVM's) inside the container to further minimize vibration.

The hydraulic system is made of a 350 bar hydraulic oil pressurization line containing pumps, control valves and safety valves to drive the lift pumps as well as a ventilation system.

A low power pump motor unit is included to drive the lift pump at low speed. This prevents sea organisms from sticking inside and outside the lift pump, as well as to support the prompt starting up of the main diesel-hydraulic system.

Cooling water for the hydraulic system and the diesel engine is obtained from the pressure line of the booster pump, ensuring the system is totally independent of external supply during any emergency.

The diesel engine fuel tanks and supply system are designed in compliance with the NFPA 20 standard and the requirements of each customer. As a minimum at least 18 hours operation with the self contained fuel reserve is guaranteed.

The starting system for the diesel engine may be electrical and/or pneumatic, being customized to the customers requirements. The latest variant is a low pressure system (30 bar) that offers higher availability with a smaller number of components reducing the risk of failure and ensuring easier maintenance.

The ventilation system is designed according to the most rigorous requirements of both customers and Classification Societies. It consists of ventilators driven by electric motors during the standby period and further ventilators driven by hydraulic motors during the diesel hydraulic system's operation. In addition to ventilators it also includes ducts and damp-

ers whose operation is set by the system design logic criteria. The container is designed to comply with the most extreme conditions (for example, centenary waves), as well as the Classification Societies design criteria.

The internal distribution of equipment and accessories, doors and removable hatches on the roof and wall, as well as the dimensions of the container, make a practical area for access to and internal maintenance of all components. Rails and lifting gear fitted to the roof of the container are included in the scope of supply in order to facilitate equipment handling within the container. Depending on the installation area of the container on board a ship or platform, the acoustic/thermal insulation of the module meets the requirements of SOLAS standards (A-0 or A-60).

Container View of the Main Components

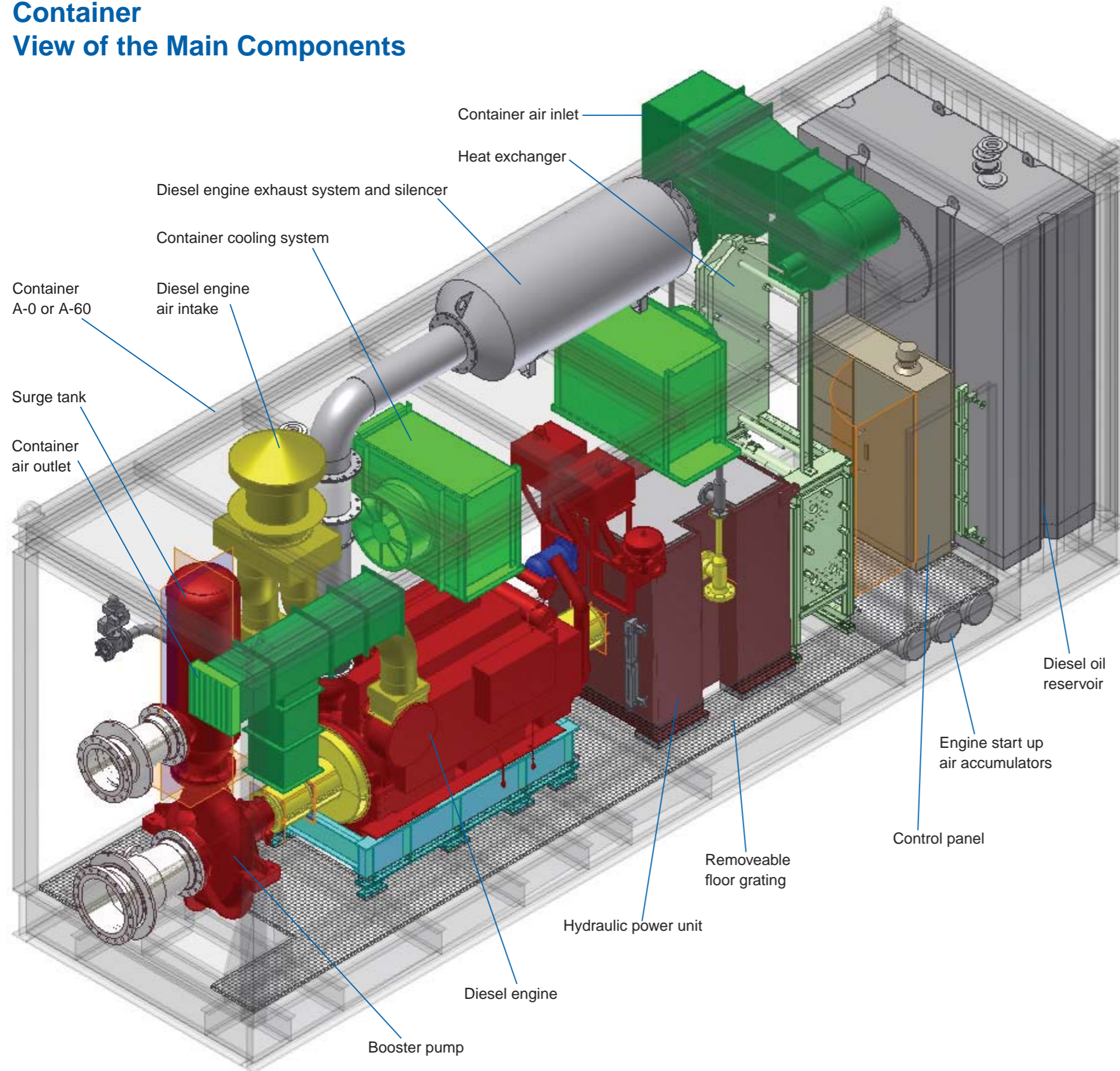

Assured Performance

All system components are field proven and go through running tests in our testing facility following the most rigorous engineering standards and criteria.

In addition, the whole fire system including lift and booster pumps, hydraulic system, diesel engine and container components (ventilation, cooling and start up system, control panel, etc) is tested in our testing facility under full load and at 150% of the operating condition (string test).

This test gives the system high reliability, granting its performance on the platform besides minimizing test, commissioning and starting up time on board.

Fire System Performance Range

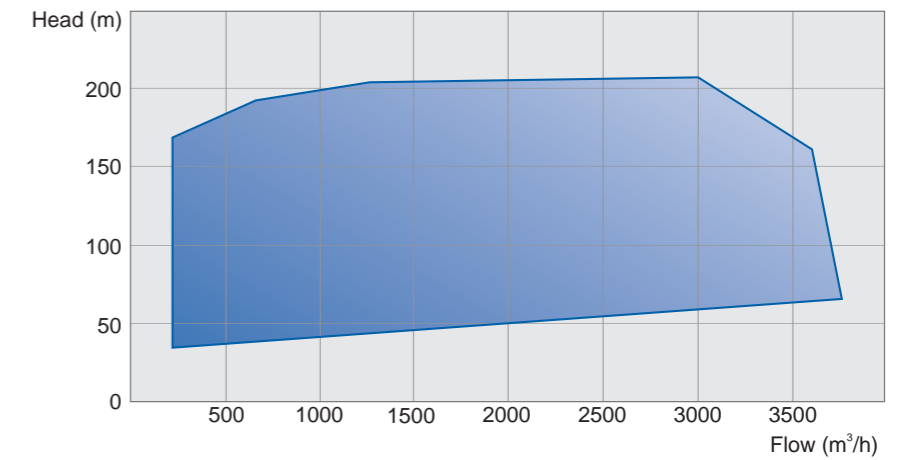

Lift Pump Submerged Centrifugal Pumps

The lift pumps are of the submerged type and hydraulically driven, lifting sea water through pipe columns.

The hydraulic system consists of high and low pressure pipe concentric to the pipe column. Due to the high operating pressures combined with corrosive attack by sea water, the materials used for the construction of the pump are either duplex (ASTM A 890 Gr. 3A) or superduplex material (ASTM A 890 Gr. 6A), depending on operating conditions.

The oil used to drive the hydraulic motor is also used for lubricating and cooling the bearings and shaft seals of the lift pump. The pressure of the hydraulic oil in the low pressure line is slightly higher than the pressure of the sea water inside the pipe column.

External pipework is provided for the injection of hypochlorite in the suction line of the lift pump below the intake filter. The filter is generously dimensioned to prevent suction pressure losses and is fitted within the suction bellmouth of the lift pump.

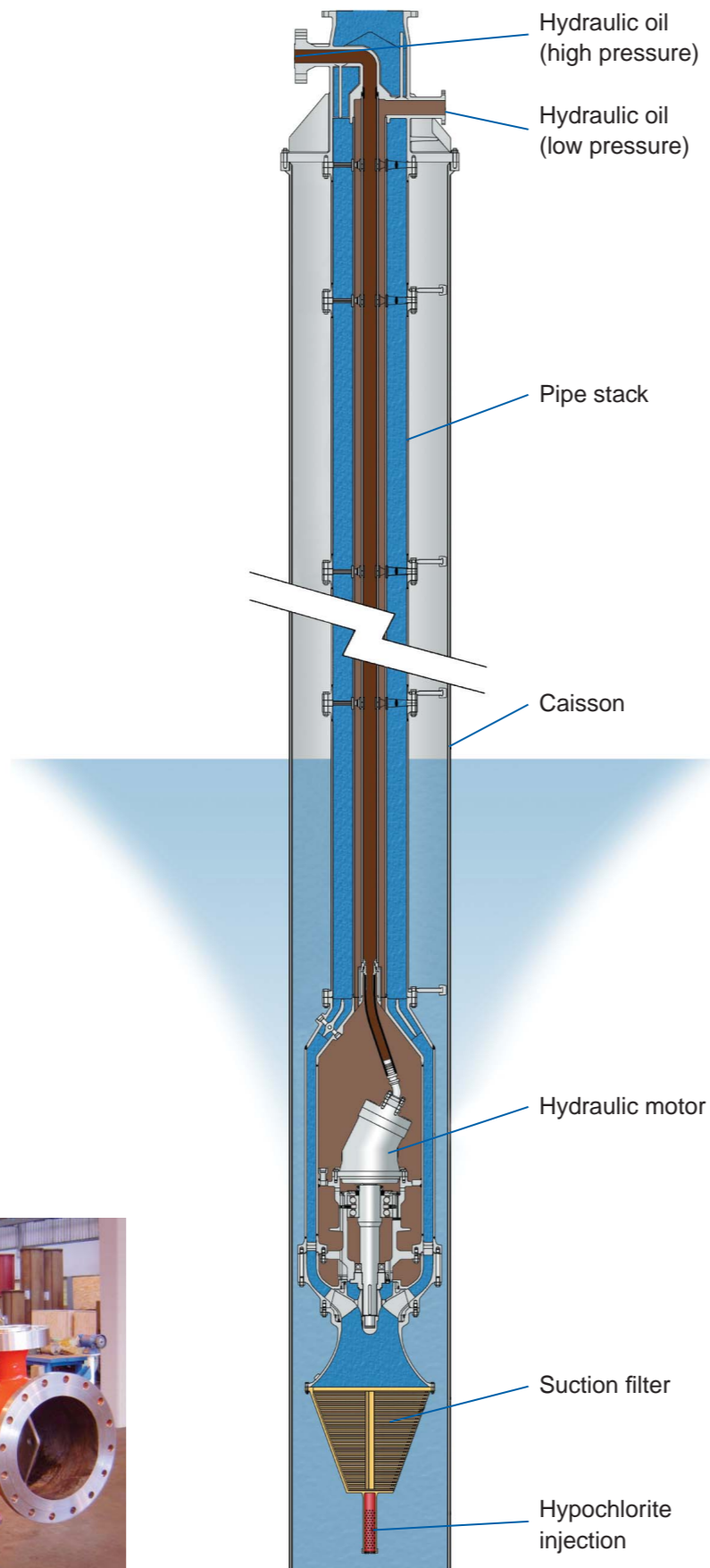

Booster Pump End Top or Axial Split Pumps

The booster pumps may be of the OH2 or BB1 type to ISO 13709 (API 610). The selection takes into consideration customer specifications as well as the operating conditions.

The shaft seals and the flushing system are designed and manufactured according to API 682 standards, allowing dry operation during startup of the diesel-hydraulic system.

The booster pumps supplied by Sulzer have NPSH req. according to ISO 13709 (NSS<11000) and perform to NFPA 20 criteria (150% of the normal operating condition), thus minimizing the pressure and the power of the lift pump. Booster pumps are manufactured in duplex or superduplex materials.

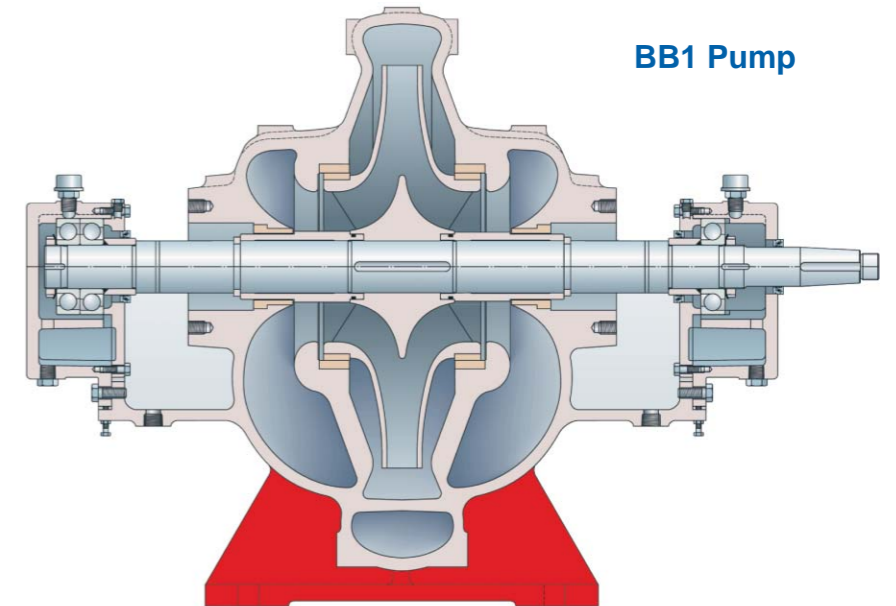
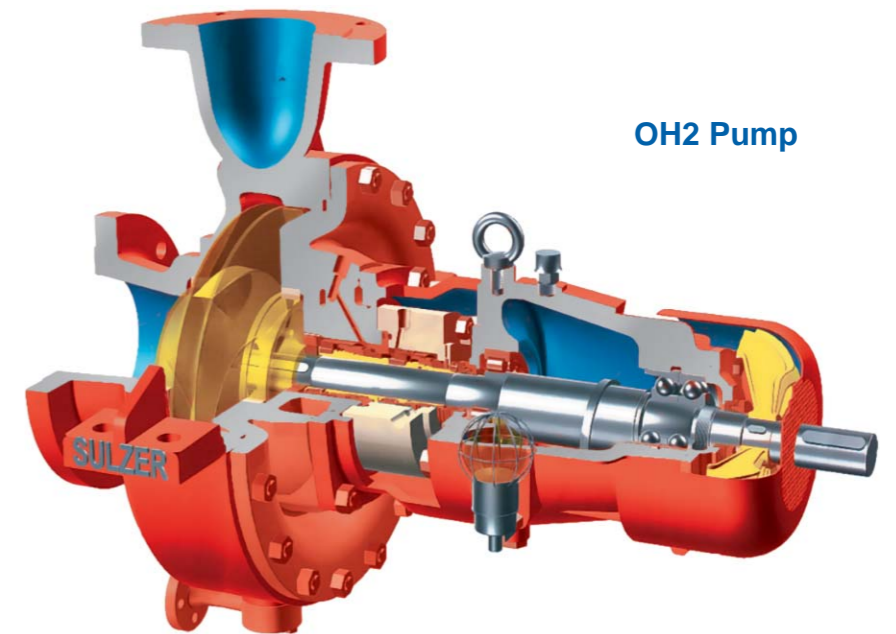

motralec

4 rue Lavoisier . ZA Lavoisier . 95223 HERBLAY CEDEX
Tel. : 01.39.97.65.10 / Fax. : 01.39.97.68.48
Demande de prix / e-mail : service-commercial@motralec.com
www.motralec.com