

motralec

4 rue Lavoisier . ZA Lavoisier . 95223 HERBLAY CEDEX

Tel. : 01.39.97.65.10 / Fax. : 01.39.97.68.48

Demande de prix / e-mail : service-commercial@motralec.com

www.motralec.com

SULZER

Sulzer Pumps

Sulzer Pumps for Cane Sugar Applications



The Heart of Your Process



Advanced Pumping Solutions for the Sugar Industry

Sulzer Pumps' AHLSTAR^{UP} series is designed according to ISO 5199 standards for continuous operation in industrial processes. One of the key features of this product line is the interchangeability of parts and components. This allows new technology to be easily incorporated into the full range of product offerings.

One crucial factor in the sugar industry is reliable sealing. In the Dynamic Seal there are no narrow areas corresponding to the sealing face area in mechanical seals where sugar can crystallize and cause sealing damage. Furthermore, there are no wearing parts, nor sealing water system requirements. That's why Sulzer Dynamic Seal can be used in every applicable sugar juice or liquid pumping application.

One of the key issues effecting on pump lifetime is material selection. Sulzer Pumps has a wide selection of alternative materials available and our own foundry in Finland is specialized in highly alloyed stainless and duplex steels.

In a globally competitive sugar industry selection of every pump is more vital than ever before. LCC (Life Cycle Cost) thinking is getting momentum and making pump selection based on designs with high pumping efficiency, low operational and maintenance costs a must. Increased pump reliability throughout the sugar process enables the use of one-pump systems without spare pumps.

Sulzer Pumps has hundreds of pumps running in demanding applications in the cane sugar industry worldwide. Our high quality products and deep understanding of sugar processes generate reliable pumping solutions to meet the needs of our customers. Let's make the best out of your sugar process pumping!





ustries

AHLSTAR^{UP} A

AHLSTAR^{UP} A process pumps are standard pumps for all the normal pumping applications.

AHLSTAR^{UP} W

AHLSTAR^{UP} W wear resistant pumps are designed for applications where durability is essential, like pumping both abrasive and corrosive liquids and slurries containing particles.

AHLSTAR^{UP} A-LM

AHLSTAR^{UP} A-LM self priming gas removal pumps enable efficient and trouble-free pumping of liquids containing gas up to 70% or when self priming pumps are needed.

AHLSTAR^{UP} N

AHLSTAR^{UP} N non-clogging pumps are suitable for the continuous pumping of liquids, slurries and stocks containing large solids and long fibers.

AHLSTAR^{UP} W-LM

AHLSTAR^{UP} W-LM wear resistant self priming gas removal pumps enable trouble-free pumping of corrosive and abrasive liquids containing gas up to 70% or when self priming pumps are needed.

AHLSTAR^{UP} N-LM

AHLSTAR^{UP} N-LM non-clogging self priming gas removal pumps for efficient pumping of liquids, slurries and stock containing large solids, long fibers and gas up to 70%, or when self priming pumps are needed.

MBN

MBN multistage ring section pumps are meant for pumping of clean or slightly contaminated liquids in high pressure applications.

SALOMIX[®] LV

SALOMIX[®] LV agitators are slow rotating vertical agitators with AF/AFX paddles for efficient sludge handling in purification of cane.

Vertical agitators

Vertical agitators with six-blade special SALOMIX[®] propellers are tailor-made for crystallization pans.

Displacement pumps

Our partner, Herold Pumpen in Germany, produces positive displacement pumps (twisted roots design) especially suited for pumping highly viscous massecuites, run-offs and molasses in sugar house up to viscosities of over 300 000 cP (centipoise).



Cane Washing (optional)

Special features: abrasion

For dirty sump waters

The AHLSTAR^{UP} N-LM non-clogging self priming gas removal pump with

- Vortex impeller
- Corrosion and wear resistant stainless steel ASTM A747 Grade CB7Cu-2
- Internal vacuum system

The AHLSTAR^{UP} W-LM wear resistant self priming gas removal pump with

- Vortex impeller
- Corrosion and wear resistant chromium iron ASTM A532 IIIA
- Internal vacuum system

For washing waters containing sand and mud

The AHLSTAR^{UP} W wear and corrosion resistant process pump with

- Open or vortex impeller
- Corrosion and wear resistant chromium iron ASTM A532 IIIA
- Unique dynamic shaft seal



Juice Extraction: Diffusion

Special features: abrasion

For the main part of the diffuser

The AHLSTAR^{UP} W wear and corrosion resistant process pump with

- Wear resistant open impeller
- Corrosion and wear resistant chromium iron ASTM A532 IIIA or duplex stainless steel ASTM A890 3A
- Unique dynamic shaft seal

For the end of the diffuser

The AHLSTAR^{UP} A process pump with

- High efficiency, low NPSHr open impeller
- Corrosion and wear resistant duplex stainless steel ASTM A890 3A or cast iron A48 CL 30 B
- Unique dynamic shaft seal



Juice Extraction: Milling Tandem

Special features: abrasion, cush-cush pumping

For juices containing cush-cush

The AHLSTAR^{UP} N non-clogging process pump with

- Vortex impeller
- Corrosion and wear resistant stainless steel ASTM A747 Grade CB7Cu-2
- Unique dynamic shaft seal

The AHLSTAR^{UP} W wear and corrosion resistant process pump with

- Vortex impeller
- Corrosion and wear resistant chromium iron ASTM A532 IIIA
- Unique dynamic shaft seal

For abrasive juices and waters after separation of cush-cush

The AHLSTAR^{UP} W wear and corrosion resistant process pump with

- Wear resistant closed impeller
- Corrosion and wear resistant chromium iron ASTM A532 IIIA
- Unique dynamic shaft seal





Juice Purification and Clarification

Special features: abrasion, SO₂-gas

For limed juices

The AHLSTAR^{UP} W wear and corrosion resistant process pump with

- Wear resistant open impeller
- Corrosion and wear resistant chromium iron ASTM A532 IIIA or corrosion and wear resistant duplex stainless steel ASTM A890 3A
- Unique dynamic shaft seal

For filtrates and clear juices

The AHLSTAR^{UP} A process pump with

- High efficiency, low NPSHr open impeller
- Corrosion and wear resistant duplex stainless steel ASTM A890 3A or cast iron A48 CL 30 B
- Unique dynamic shaft seal

For gas containing sulphited juices

The AHLSTAR^{UP} A-LM self priming gas removal process pump with

- High efficiency, low NPSHr open impeller
- Corrosion and wear resistant duplex stainless steel ASTM A890 3A
- Internal vacuum system

For milk of lime

The AHLSTAR^{UP} W wear and corrosion resistant process pump with

- Wear resistant open impeller
- Corrosion and wear resistant chromium iron ASTM A532 IIIA
- Unique dynamic shaft seal

Agitation or mixing of limed juices and filtrates

The SALOMIX[®] LA agitator with

- Direct drive or belt drive
- SALOMIX[®] bearing frame
- High efficiency, CP-propeller(s), plus several impeller options
- SS2343 material for parts in contact with liquid

The SALOMIX[®] LV agitator with

- Versatile gear drive
- High efficiency, axial flow AF/AFX paddles
- SS2343 material for parts in contact with liquid

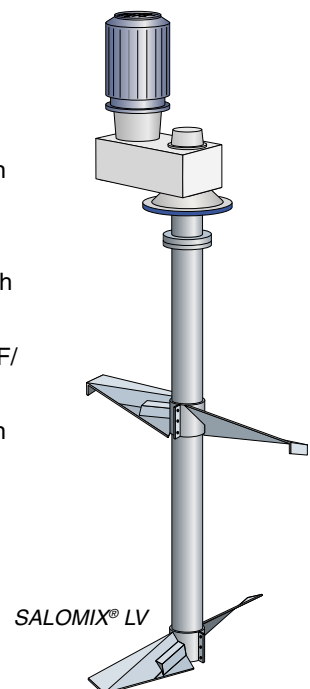



Evaporation

Special features: high temperatures

For juices

The AHLSTAR^{UP} A process pump with

- High efficiency, low NPSHr open impeller
- Corrosion and wear resistant duplex stainless steel ASTM A890 3A or cast iron A48 CL 30 B (maximum temperature 120 °C),
- Ready fitted mechanical shaft seal

For condensates

The AHLSTAR^{UP} A process pump with

- High efficiency, low NPSHr closed impeller
- Corrosion resistant stainless steel ASTM A890 3A or cast iron A48 CL 35B (maximum temperature 120 °C)
- Ready fitted mechanical shaft seal for boiling waters
- Unique dynamic shaft seal for non-boiling waters

Crystallization

Special features: high viscosities and gas-containing run-offs

Low viscous run-offs and molasses

The AHLSTAR^{UP} A-LM self priming gas removal process pump with

- High efficiency, low NPSHr open impeller
- Corrosion and wear resistant duplex stainless steel ASTM A890 3A
- Internal vacuum system

For massecurites and high viscous thick juices, run-offs and molasses

The Herold twisted roots positive displacement pump (viscosities up to 300 000 cP).

Agitation or mixing of syrups, run-offs or molasses

The SALOMIX[®] LV agitator with

- Versatile gear drive
- Special high axial flow propeller
- Different seal options
- SS2343 material for parts in contact with liquid



Power Station

Special features: high pressure, abrasion

For high pressure waters to feed the boiler

The MBN multistage ring section pump with

- Closed impeller
- Corrosion and wear resistant duplex stainless steel ASTM A890 3A
- Ready fitted mechanical shaft seal for boiling water
- Unique dynamic shaft seal for non-boiling water

For scrubbed feed water

The AHLSTAR^{UP} W wear and corrosion resistant process pump with

- Wear resistant closed impeller
- Corrosion and wear resistant chromium iron ASTM A532 IIIA
- Unique dynamic shaft seal



AHLSTAR^{UP} W

Other Utilities

Water transport

The B series of vertical line shaft pumps consist of BK, BS and BP ranges. They are primarily used in water lift, transfer and cooling water applications.

NVP non-clogging vertical pumps are intended for all kinds of hard applications with waste water, slurries or waste stock.

SM or SMN single stage double entry pumps are used across a broad range of industries in liquid transport and transfer applications.

ZPP double suction pumps are designed for applications including pumping of large quantities of cooling and circulating waters.

High pressure applications

The MBN multistage ring section pumps are used for pumping clean or slightly contaminated liquids in high pressure applications in various industries.

The M series of ring section multistage pumps consist of MB, MD and ME ranges. A wide range of common hydraulic components and bearing assemblies are used within the four standard pressure ranges.

Dewatering

The MBN multistage ring section pumps are specifically designed for dewatering applications. Their robust construction is designed to combat the highly abrasive environment in which they operate.



Diffusion

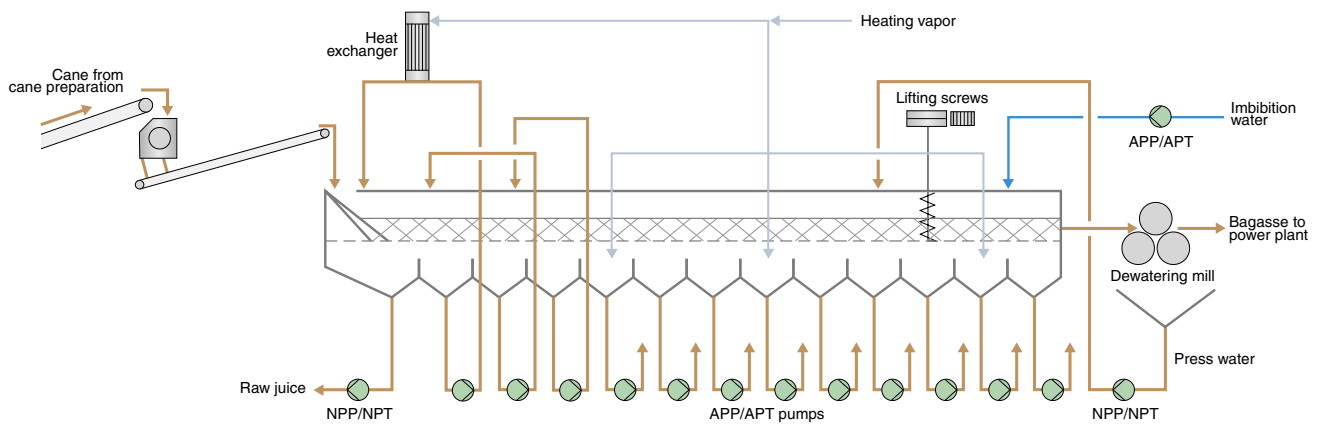

Milling tandem

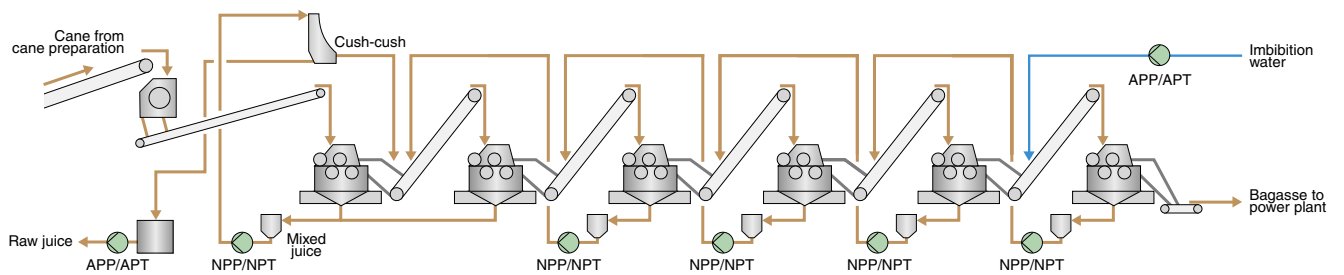



Juice purification and clarification

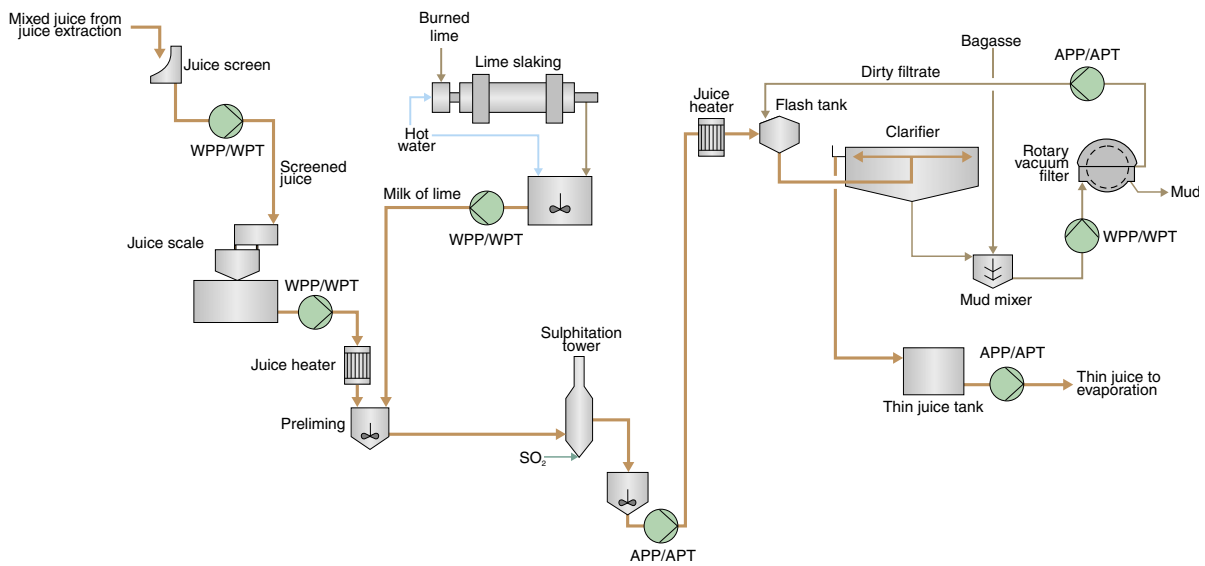

Evaporation

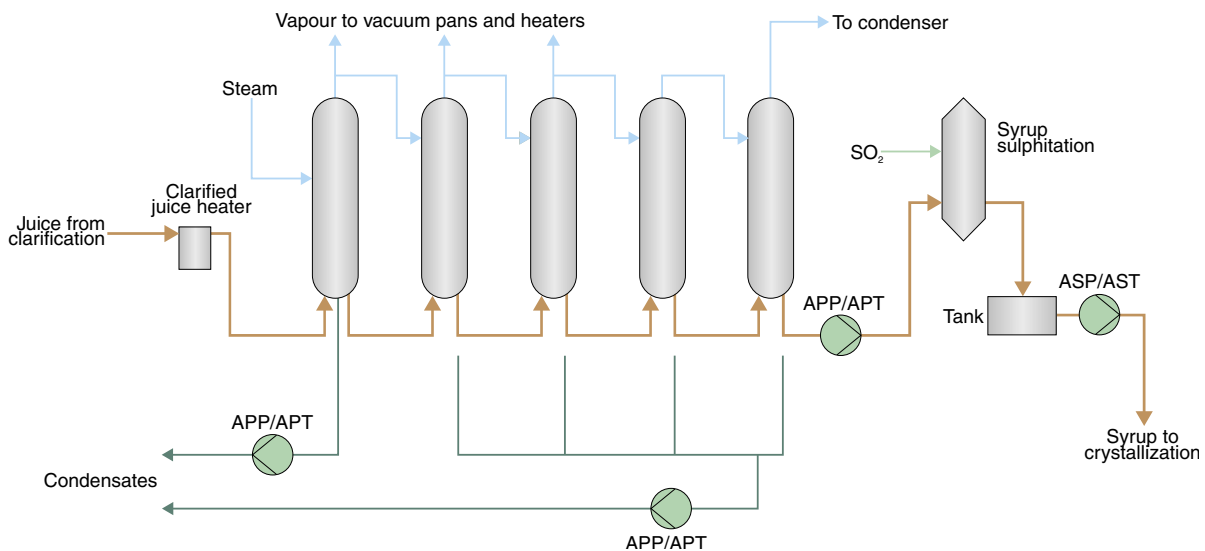



Crystallization

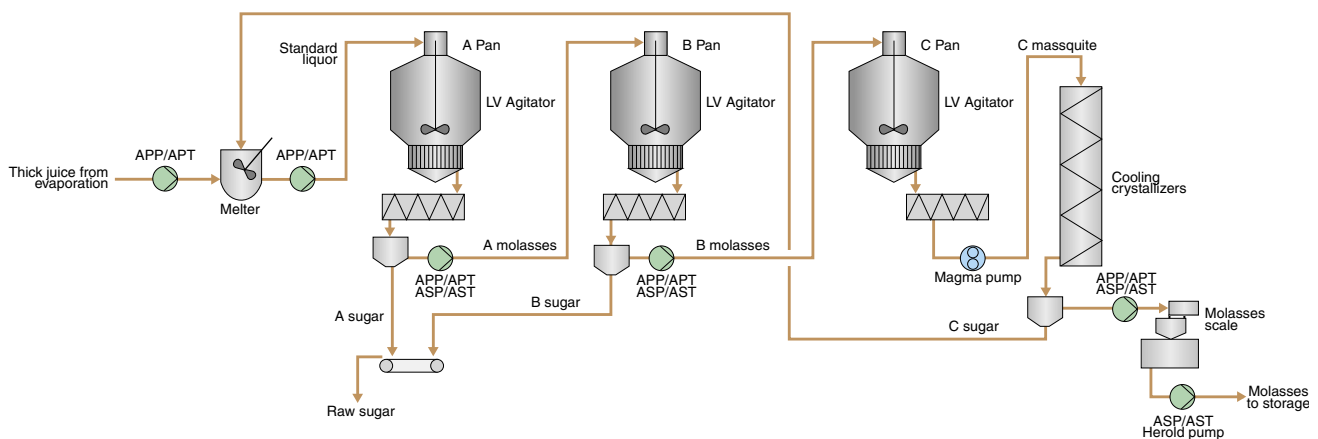

Maintaining and Improving Pump Performance

Customer Support Service

The continuous availability and high operating performance of pumps is the key target for our customer support service organization. Through our highly experienced personnel and application knowledge, we provide a full range of innovative service solutions to our customers to keep their pumps running including;

- Spare Parts
- Field Service
- Repair Services
- Retrofits
- Maintenance Agreements
- Operation Agreements

Flexibility

With services ranging in scope from supplying a spare part to operating the pump under contract, we are uniquely placed to make your process run smoother. A dedicated team of CSS specialists based at either our manufacturing facilities or one of over 50 service centers located around the world is dedicated to maintaining the performance of our customers' pumps and associated equipment. This service is not just limited to Sulzer products, all the pumps our customers operate can benefit from the support of Sulzer CSS specialists.

motralec

4 rue Lavoisier . ZA Lavoisier . 95223 HERBLAY CEDEX
Tel. : 01.39.97.65.10 / Fax. : 01.39.97.68.48
Demande de prix / e-mail : service-commercial@motralec.com
www.motralec.com

