

### CPT ANSI Process Pumps

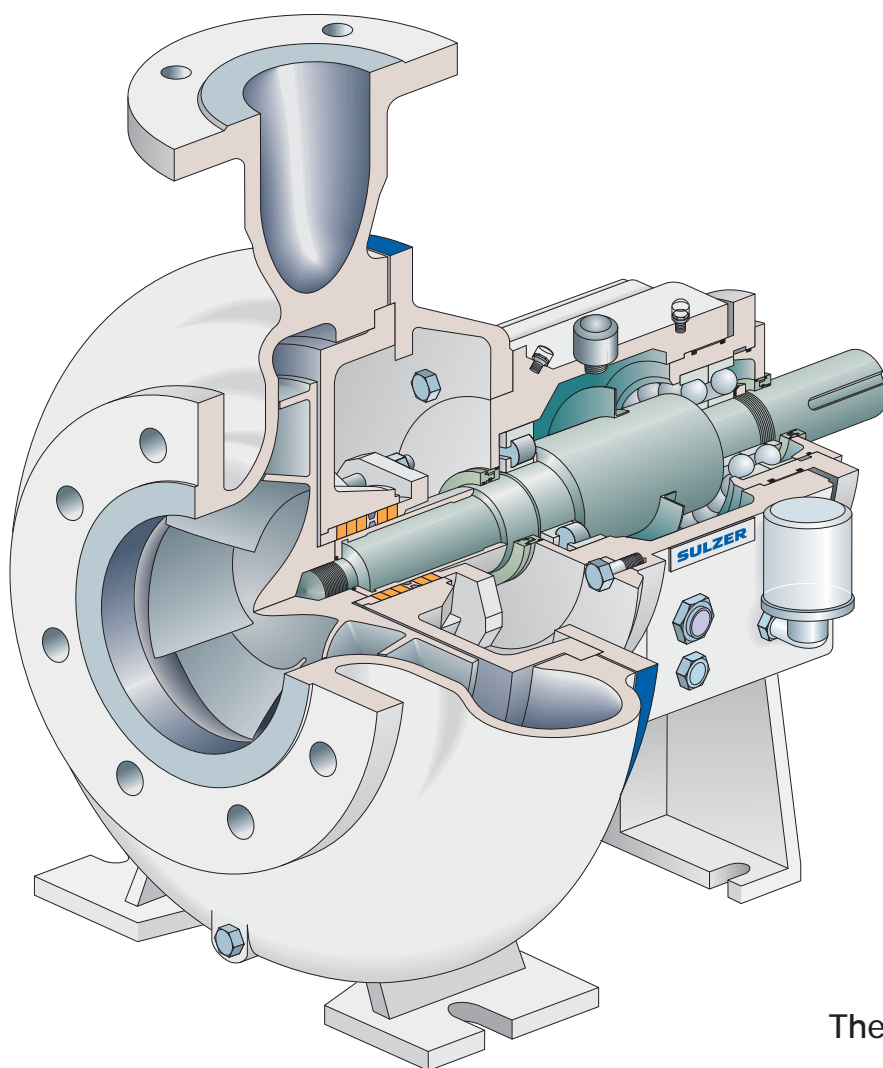

The Heart of Your Process

**motralec**

4 rue Lavoisier . ZA Lavoisier . 95223 HERBLAY CEDEX  
Tel. : 01.39.97.65.10 / Fax. : 01.39.97.68.48  
Demande de prix / e-mail : [service-commercial@motralec.com](mailto:service-commercial@motralec.com)  
[www.motralec.com](http://www.motralec.com)

# There Are Two Sides to Every Story: Inside and Outside

On the outside, the CPT offers special features that simplifies maintenance and adjustments. The real difference between the CPT and other ANSI pumps, however, is what you'll find inside. For example, the standard CPT wet-end components are cast in duplex stainless steel (unless specified otherwise). Another example is our heavy-duty bearing unit, designed for long life and tough applications. As you can see, our CPT ANSI process pump gains its advantage from the inside-out.

## Centerline Discharge

- Back pull-out design allows maintenance of the rotating assembly without disturbing the piping
- Provides self-venting for air elimination
- Equalizes distribution of pipe stress through integral feet

## Heavywalled Casing

- Computer generated hydraulics
- Corrosion allowance for extended wear

## Large Diameter Shaft

- Low shaft deflection (.002")
- Improved bearing and mechanical seal life
- Solid shaft or hook sleeve design available
- Duplex stainless steel standard

## Semi-Open Impeller

- Optimal computer generated hydraulics
- Investment casting guarantees smooth surfaces
- Back pump-out vanes for control of stuffing box pressure and axial thrust
- Handles solids and fibrous materials
- Low Flow option
- Teflon®\* impeller o-ring

## Sulzer Quality Castings

- Precision cast parts utilizing the latest casting techniques
- Full range of materials from Ductile Iron, Duplex stainless steel to 654 SMO™
- ISO 9001:2000 approved manufacturing processes

## Sealing Versatility

- A variety of rear covers/stuffing box designs are available to meet process requirements
- Packing
  - Large bore
  - Taper bore (cast-in ribs for flow enhancement)
- Mechanical seal
- Dynamic seal

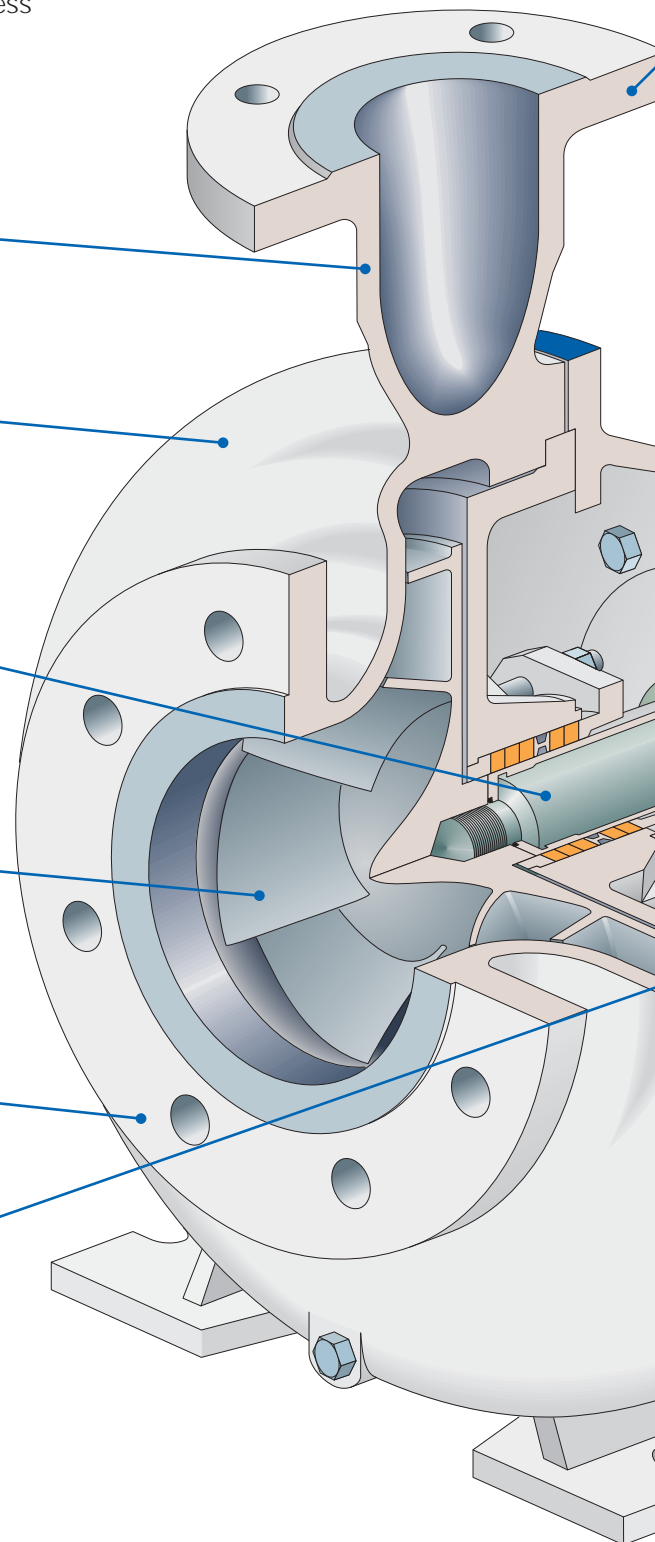

\* Teflon® is a registered trademark of E.I. Du Pont De Nemours & Company.

### Flanges

- Meet ASME/ANSI B16.5
- Class 150 RF Standard, Optional: Class 300 RF

### Bearing Housing Adapter

- Ductile iron for strength and safety
- Jacking bolts for ease of disassembly
- Rabbeted fit to bearing housing assures accurate alignment

### Bearing Monitor

- Taps as standard

### Impeller Clearance Adjustment

- Quick and accurate impeller adjustments without the use of a feeler gauge or removal of the pump
- Assures concentricity and bearing alignment throughout the impeller's adjustable range
- No snap ring required to hold bearing

### Heavy Duty Bearings

- Bearing life exceeds all ANSI requirements
- Inboard cylindrical roller bearings for maximum radial load carrying capabilities
- Angular contact thrust bearing locked into position, carries radial and axial loads extending service life

### Inpro VBX/Labyrinth Bearing Isolators

- Inboard and outboard bearing protection
- Isolates bearings from environmental contamination
- Multi-port for proper drainage
- Bronze standard (non-metallic available)
- Cooler running bearing unit

### Splash Lubrication

- Directs oil to bearings for efficient cooling and improved lubrication
- Designed for high load applications

### Large Capacity Oil Sump

- Improved oil circulation and cooling
- Magnetic oil drain plugs (optional)
- Extra-large, multiple oil return slots
- Optional bearing unit cooling

### Constant Level Oiler Available

### Over Sized Sight Glass

- Located on each side of the bearing unit

### Rigid Bearing Housing Support Foot

- Improved mounting stability
- Fully machined mounting surfaces assures accurate alignment

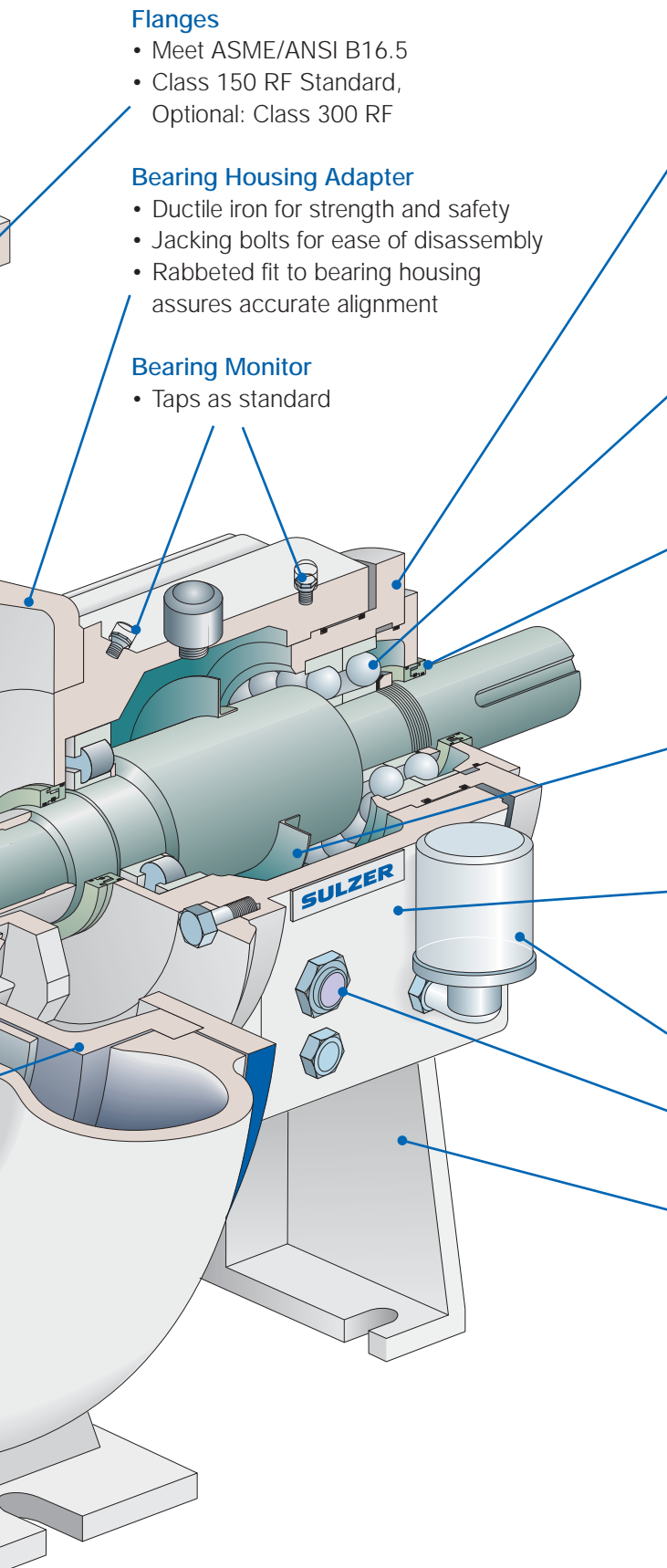

# Hydraulic Coverage

## Capacity Range 3600 rpm

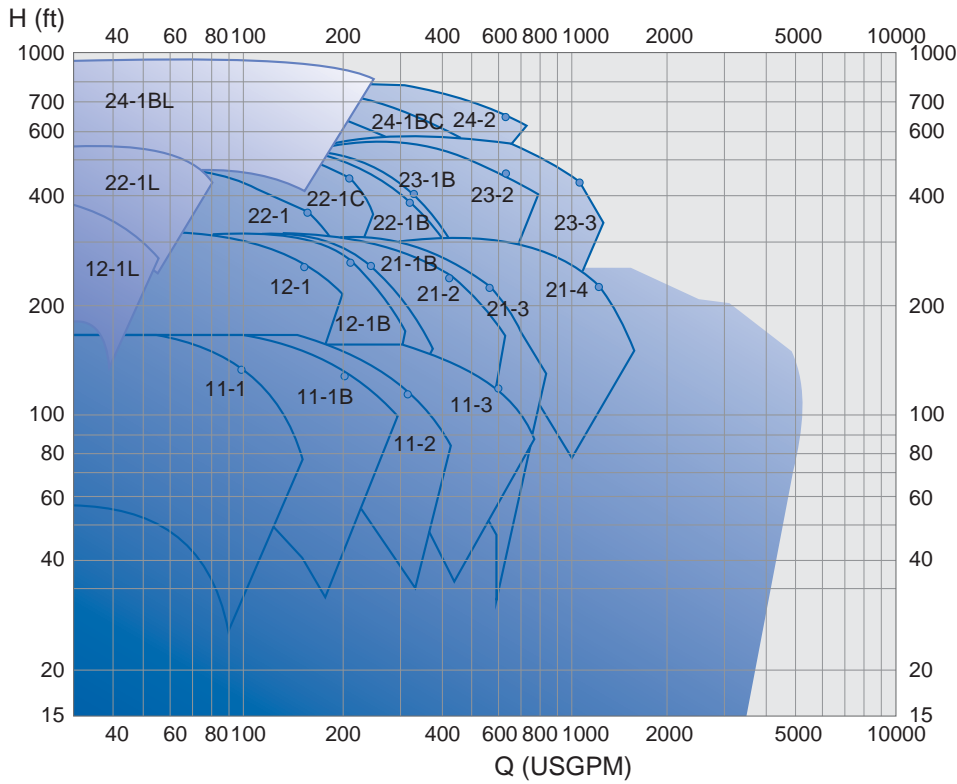

## Capacity Range 1800 rpm

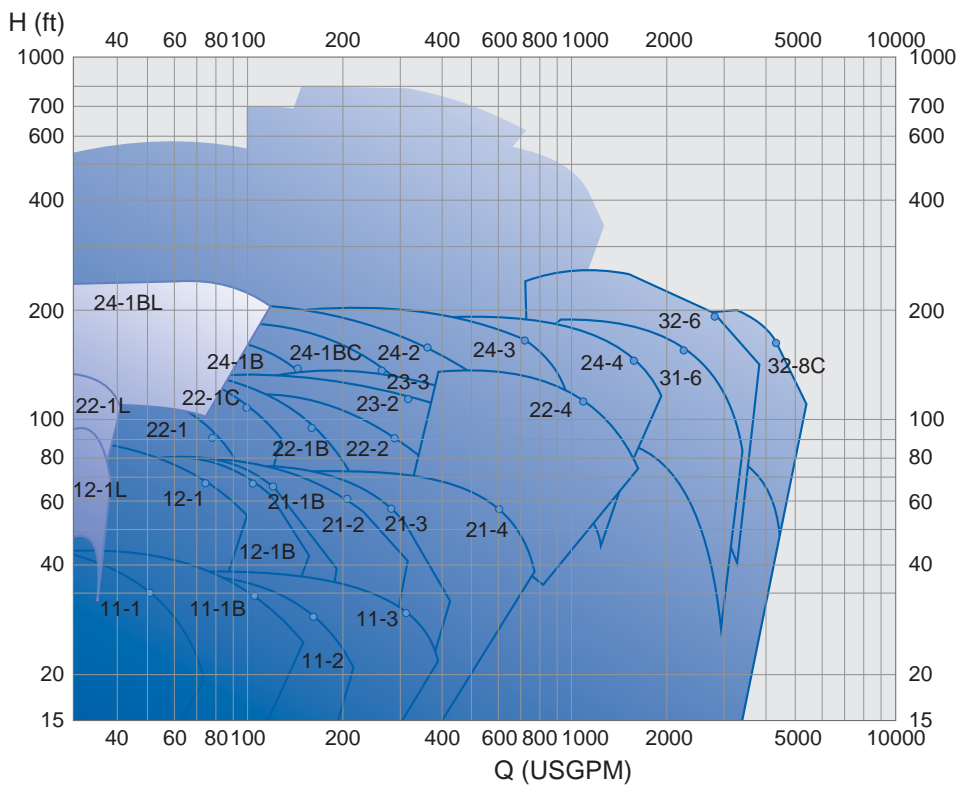

● Best efficiency point

# Dimensions

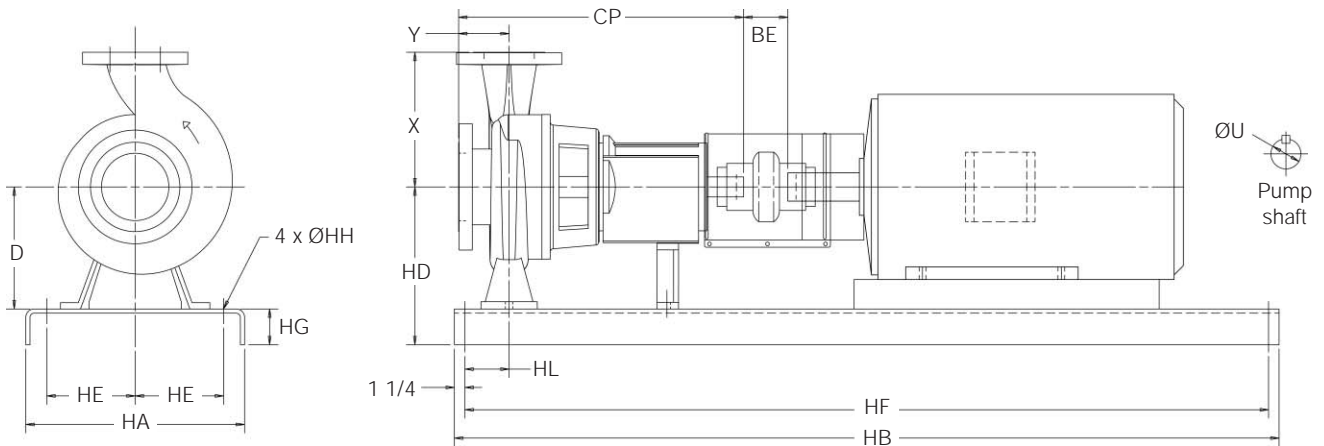

## CPT Pump Dimensions

Group	Pump	Size	CP	Y	X	BE	D	ØU
1	11-1	1.5x1x6	17.5	4	6.5	3.875	5.25	7/8
	11-1B	3x1.5x6	17.5	4	6.5	3.875	5.25	7/8
	11-2	3x2x6	17.5	4	6.5	3.875	5.25	7/8
	11-3**	4x3x6	18	4	8.5	3.875	7	7/8
	12-1	1.5x1x8	17.5	4	6.5	3.875	5.25	7/8
	12-1L	1.5x1x8	17.5	4	6.5	3.875	5.25	7/8
2	12-1B	3x1.5x8	17.5	4	6.5	3.875	5.25	7/8
	21-1B	3x1.5x8.5	23.5	4	8.5	3.875	8.25	1 3/8
	21-2	3x2x8.5	23.5	4	9.5	3.875	8.25	1 3/8
	21-3	4x3x8.5	23.5	4	11	3.875	8.25	1 3/8
	21-4	6x4x8.5	23.5	4	11	3.875	8.25	1 3/8
	22-1	2x1x10	23.5	4	8.5	3.875	8.25	1 3/8
	22-1L	2x1x10	23.5	4	8.5	3.875	8.25	1 3/8
	22-1C	2x1x10C*	23.5	4	8.5	3.875	8.25	1 3/8
	22-1B	3x1.5x10	23.5	4	8.5	3.875	8.25	1 3/8
	22-2	3x2x10	23.5	4	9.5	3.875	8.25	1 3/8
	22-4	6x4x10	23.5	4	13.5	3.875	10	1 3/8
	23-1B	3x1.5x11	23.5	4	10.5	3.875	10	1 3/8
	23-1BL	3x1.5x11	23.5	4	10.5	3.875	10	1 3/8
	23-2	3x2x11	23.5	4	11.5	3.875	10	1 3/8
	23-3	4x3x11	23.5	4	12.5	3.875	10	1 3/8
	24-1B	3x1.5x13	23.5	4	10.5	3.875	10	1 3/8
24-1BC	3x1.5x13C*	23.5	4	10.5	3.875	10	1 3/8	
3	24-2	3x2x13	23.5	4	11.5	3.875	10	1 3/8
	24-3	4x3x13	23.5	4	12.5	3.875	10	1 3/8
	24-4	6x4x13	23.5	4	13.5	3.875	10	1 3/8
	31-6	8x6x13	33.875	6	16	5.25	14.5	2 3/8
	32-6	8x6x15	33.875	6	18	5.25	14.5	2 3/8
	32-8C	10x8x15C*	33.875	6	19	5.25	14.5	2 3/8
	32-8	10x8x15	33.875	6	19	5.25	14.5	2 3/8

## CPT Base Dimensions (not for construction)

Group	Base	Max motor frame	HA	HB	HE	HF	ØHH	HL	HG max	HD max
1	139	184T	15	39	4.5	36.5	3/4	4.5	3.75	9
	148	256T	18	48	6	45.5	3/4	4.5	4.13	10.5
	153	326TS	21	53	7.5	50.5	3/4	4.5	4.75	12.88
2	245	184T	15	45	4.5	42.5	3/4	4.5	3.75	12/13.75***
	252	215T	18	52	6	49.5	3/4	4.5	4.13	12.38/14.13***
	258	286T	21	58	7.5	55.5	1	4.5	4.75	13/14.75***
	264	365T	21	64	7.5	61.5	1	4.5	4.75	13/14.75***
	268	405TS	26	68	9.5	65.5	1	4.5	4.75	14.75
	280	449TS	26	80	9.5	77.5	1	4.5	4.75	15.25
3	368	286T	26	68	9.5	65.5	1	6.5	4.75	18.75
	380	405T	26	80	9.5	77.5	1	6.5	4.75	18.75
	398	449T	26	98	9.5	95.5	1	6.5	4.75	18.75

\* Designates higher hydraulic range.

\*\* Note that CPT 11-3 is not part of ANSI specification and may have different dimensions.

\*\*\* Note that numbers depend on pump size D=8.25"/D=10".

# Materials

## A-890 grade 3A Alloy

Sulzer CPT ANSI pumps are frequently used in services where resistance to both corrosion and abrasion is necessary. That is why the standard stainless steel chosen for wet-end pump components is ASTM A-890 Grade 3A.

This duplex cast steel (ferritic austenitic) with high molybdenum and nitrogen content:

- Offers corrosion resistance superior to conventional cast 316SS (CF-8M) and equal to or better than 317SS (CG-8M).

- Provides excellent abrasion resistance (230 BHN) that, when used in mildly abrasive services, may last 30% to 40% longer than 316SS.
- Features clearly superior mechanical properties over austenitic alloys and is comparable to most duplex alloys including CD4-MCu and SS2205.

## CPT Material Mechanical Properties

Common name	ASTM	Mechanical properties			
		Tensile	Yield	Elong %	Hardness
Cast iron	A278 CL200	29			170-220
CD6MN	A890-3A	95	65	25	180-260
2205	A890-4A	90	60	25	180-260
5A	A890-5A	100	75	18	180-260
CD4MCuN	A890-1B	100	70	16	160-200
Ductile iron	A395	60	40	18	160
329SS	AISI329	87-116	58	18	180-260
316SS	A743 CF-8M	70	30	30	150-190
317SS	A743 CG-8M	75	35	25	150-190
Alloy 20	A743-CN-7M	62	25	35	130-170
654 SMO*	*A240,480,358*	109	62	40	190-220

## CPT Material Chemical Properties

Common name	Chemical analysis									
	Cr	Ni	Mo	Cu	Si	Mn	C	N	PRE	ASTM
Cast iron					1.7-2.4	0.4-0.09	3.2-3.7		NA	A278 CL200
CD6MN	24.0-27.0	4.0-6.0	1.75-2.5		0.04	1	0.06	0.15-0.25	35.60	A890-3A
2205	21.0-23.5	4.5-6.5	2.5-3.5	1.0 max	0.02	1.5	0.03	0.1-0.3	35.10	A890-4A
5A	24.0-26.0	6.0-8.0	4.0-5.0		1.0	1.5	0.03	0.1-0.3	43.00	A890-5A
CD4MCuN	24.5-26.5	4.6-6.0	1.75-2.25	2.75-3.25	1.0	1.0	0.4	0.15	35.30	A890-1B
Ductile iron					2.0-2.8	0.2-0.7	3.1-3.7		NA	A395
329SS	24.0-27.0	4.5-7.0	2.5-3.0		1.0				34.08	AISI329
316SS	18.0-21.0	9.0-12.0	2.0-3.0		2.0		0.08		27.50	A743 CF-8M
317SS	18.0-21.0	9.0-13.0	3.0-4.0		1.5		0.08		30.90	A743 CG-8M
Alloy 20	19.0-21.0	27.5-30.5	2.0-3.0	3.0-4.0	1.0	1.7	0.07		30.00	A743 CN-7M
654 SMO*	24.0-25.0	21.0-23.0	" 7.0-8.0"	0.30-0.60	0.5	2.0-4.0	0.02	0.45-0.55	56.1	A240.480,358

\* AVESTA 654 SMO is a trademark owned by Outokumpu Stainless which has granted Sulzer Pumps licence to produce this material.

### Corrosion Resistance

Pitting and crevice corrosion that occurs in metals are of particular interest in stainless steel.

The Pitting Resistance Equivalence (PRE\*) is an index that can help identify an alloy's susceptibility to these forms of corrosion. The higher the PRE\* number, the greater the metal's resistance to pitting and crevice corrosion.

ASTM	PRE*
A890-3A	35.6
A743 CF-8M	27.5
CD4MCu	35.30
AISI329	34.08
A743 CN-7M	30.0
A743 CG-8M	35.10

\*(PRE = Cr% + 3.3 Mo% + 16 x N%)

### Heat Treatment

All A-890 Grade 3A castings are solution annealed to maximize corrosion resistance and mechanical properties. This heat treatment consists of heating to and holding at 1950°F minimum for a prescribed time period followed by a rapid water quench.

### Welding

A-890 Grade 3A is a readily weldable metal provided a matching weld filler is used.



## Sulzer CPT-LF Pumps – Designed for Your Demanding Low Flow Applications

Not all end suction pumps are intended to be run at low flow/high head conditions. The Sulzer CPT Low-Flow ANSI pump is specifically designed to eliminate hydraulic and mechanical issues normally experienced at these operating points.

Standard ANSI pumps are typically throttled back to meet low flow conditions. This may cause higher than normal radial loads and shaft deflection, resulting in premature bearing and mechanical seal failure.

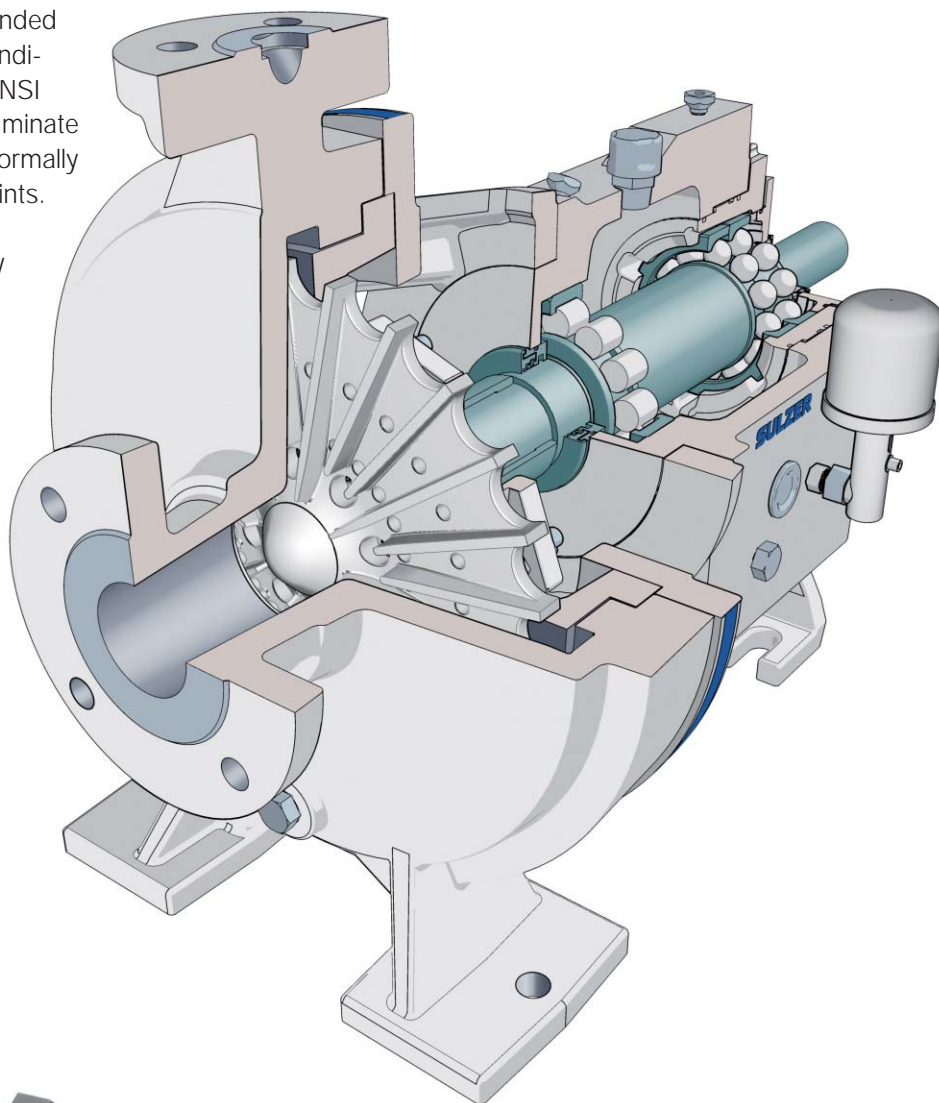

The Sulzer radial vane impeller and concentric casing design greatly reduce this problem. Matched with our no-cost standards of inboard roller bearings and duplex angular contact outboard bearings, the Sulzer CPT ANSI Low-Flow pump will extend the MTBF and reduces overall maintenance costs.

# Shaft Sealing

## Dynamic Seal

Sulzer Pumps' dynamic seal uses an expeller to move liquid back into the volute casing and away from the stuffing box when the pump is running. When the pump stops, liquid flows back into the stuffing box, forcing closed an elastomeric static seal to prevent leakage. No outside flush required. Saves water, piping costs and eliminates packing maintenance.

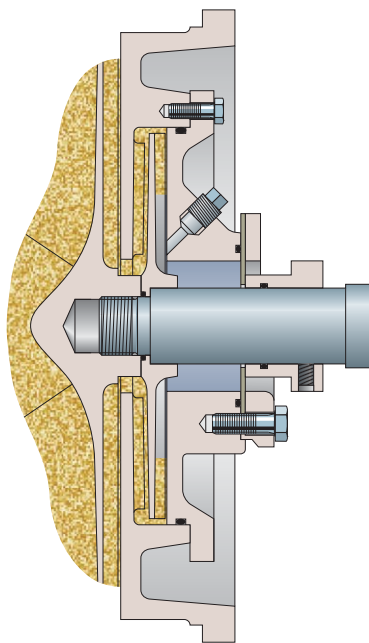

Sulzer Dynamic Seal running

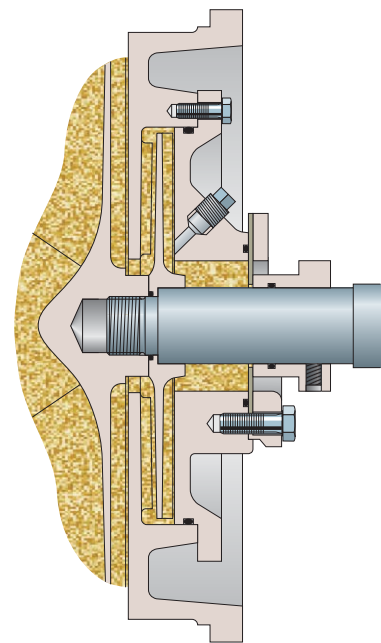

Sulzer Dynamic Seal stopped

## Seal Chambers

The CPT design offers a variety of seal chambers. Each is designed to help you tailor your CPT pump to your specific process requirements

without sacrificing reliability and longevity. If you're not exactly sure which configuration is best for your processes, our engineers will be

happy to work with you. We'll analyze your hydraulic requirements and recommend a system.

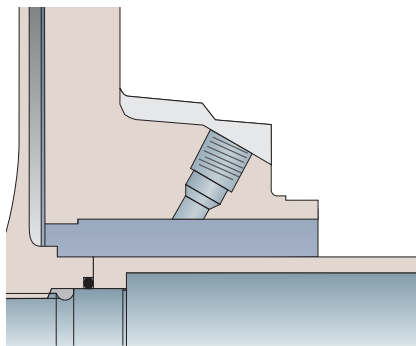

**Standard Bore Box** accommodates most single component and cartridge mechanical seals as well as standard packing.

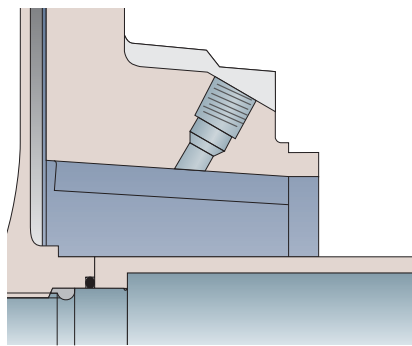

**Tapered and Ribbed Bore Box** features a seal chamber designed for single and double mechanical seals. The cast ribs inside the stuffing box convert circular flow into axial flow, reducing wear and extending longevity.

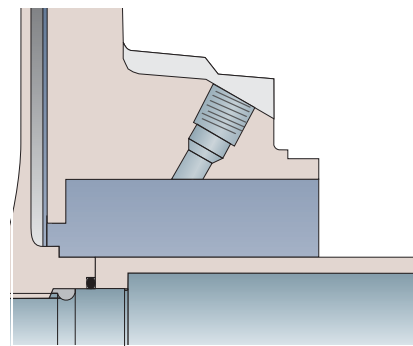

**Large Bore Box** is designed for seals with large gland bolt circles. It accommodates most single and double mechanical seals, as well as cartridge or component seals. The oversized chamber helps reduce running temperatures while improving lubrication and circulation.

# Baseplate Options

Sulzer produces rigid baseplate designs that resist the distortion which can cause pump/motor misalignment. Our baseplates require minimal maintenance and are corrosion resistant for severe environments. Sulzer Pumps offers a complete range of mounting systems to meet your requirements. Optional V-belt and custom designs are also available. Contact your local Sulzer representative for details.

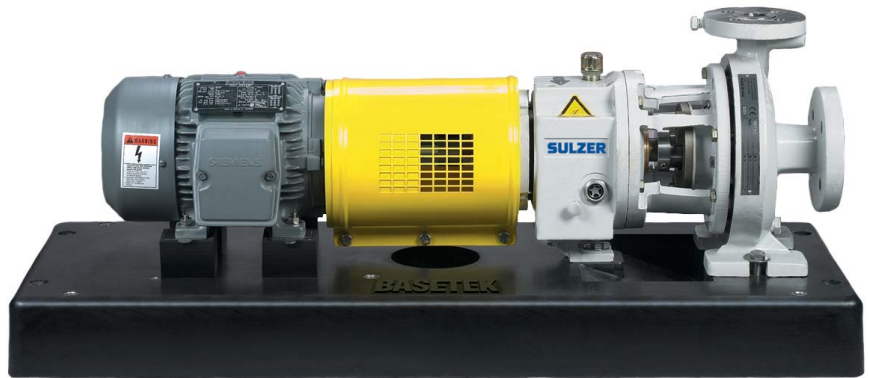

## Standard Baseplate (Style 1)

Sulzer Pumps standard formed steel baseplate meets ANSI specifications for pump/motor mounting. A single grout hole and epoxy paint are standard. An optional stainless steel catch basin or all stainless steel construction is available.



## Non-Metallic Baseplate

Nothing compares to the Sulzer Polymer Composite baseplate design. The polymer baseplate is provided with a standard guaranteed surface flatness of 0.015" or 0.005" end-to-end, carbon or SS inserts, leveling holes and machined riser blocks. The polymer baseplate is the best value in the industry.



## Drip-Lip Baseplate (Style 3)

The Drip-lip baseplate with welded end caps and optional center I-Beam support includes a sloped drainage channel to a welded drain connection making this an excellent upgrade to the standard baseplate. Options include motor adjustment bolts, additional grout vent holes and all stainless steel construction.



## PIP Baseplate

This baseplate is designed to current PIP requirements and is standard with grout hole, raised mounting pads machined to 0.002 in/ft surface flatness, motor alignment bolts, additional welded supports, sloped full drain rim, lifting lugs and continuous welded steel construction. Options include leveling screws, stilt and spring mounting and all stainless steel construction.



## Bearing Unit

The bearing unit is built as standard for high load applications. Some applications push a power end beyond ANSI design limits.

Examples are:

- 1) operation at reduced flows
- 2) pumping high specific gravity liquids
- 3) overhung belt drives

The bearing unit features as standard:

- Splash oil lubrication
- Thrust bearing is duplex angular contact bearing design (\*)
- Radial bearing is cylindrical roller bearing design (\*)
- Large oil capacity to reduce temperature
- Inpro VBX/labyrinth bearing isolators
- Grease lubrication available as an option

\*) See engineering data for bearing details.

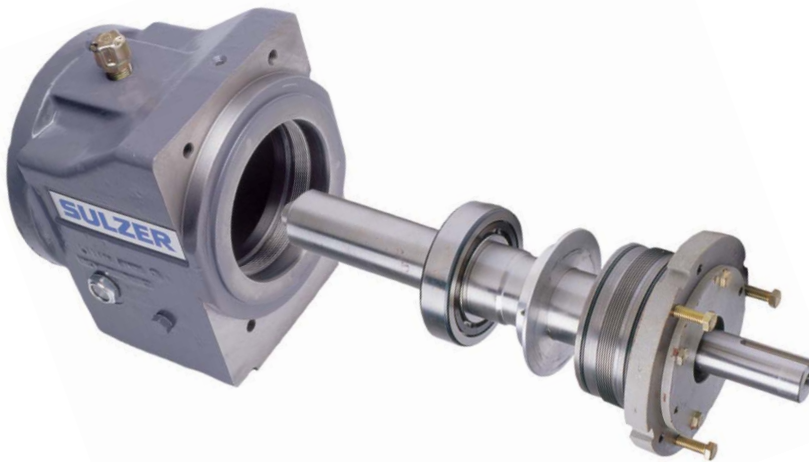

## Impeller Clearance Adjustment

- Quick and accurate impeller adjustments without the use of a feeler gauge or removal of pump
- Assures concentricity and bearing alignment throughout the impeller's adjustable range
- No snap ring required to hold bearing



# Remanufactured Bearing Unit Exchange Program

At Sulzer Process Pumps we are dedicated to providing rapid turn around, high quality remanufactured bearing units. Operators can put equipment repaired by us back into service confident in the knowledge that it is "good as new".



Customer



Sulzer Process Pumps  
Service Center



## Maintaining and Improving Pump Performance

The continuous availability and high operating performance of pumps is the key target for our customer support service organization. Through our highly experienced personnel and application knowledge, we provide a full range of innovative service solutions to our customers to keep their pumps running including;

- Spare Parts
- Field Service
- Repair Services
- Retrofits
- Maintenance Agreements

With services ranging in scope from supplying a spare part to value added services. A dedicated team of CSS specialists based at either our manufacturing facilities or one of over 50 service centers located around the world is dedicated to maintaining the performance of our customers pumps and associated equipment. This service

is not just limited to Sulzer products, all the pumps our customers operate can benefit from the support of Sulzer CSS specialists.

# Original Spare Parts

## Original Spare Parts Ensure Optimum Pump Performance

Sulzer Pumps original spare parts maintain equipment performance by

- Restoring high operational efficiency
- Optimizing energy consumption
- Minimizing unexpected failures

Original equipment spare parts are often more than a simple 'new for old' replacement. Our commitment to continuous improvement often allows us to supply replacement parts with enhanced performance over the original. Sulzer Pumps spare parts are at the heart of innovative new hydraulic and mechanical designs or sealing solution retrofits that extend equipment life and reduce maintenance costs.

## Fast, Reliable, Single Source Delivery

All parts for Sulzer pumps, from bearings and gaskets to impellers and casings, are available through the global Sulzer Customer Support Services network.

For standard stock items, consolidated warehousing and advanced logistics contribute to rapid response and delivery of parts.

Sulzer original spare parts are machined to the correct profiles, tolerances and clearances, to give a perfect fit first time, every time.

This together with broad parts interchangeability brings

- Faster maintenance – less down-time
- Reduction of spare part inventories
- High equipment performance
- Parts traceability and compliance



For our standard pump ranges, modular structures enhance upgrading and maintenance. Sub-assemblies and kits make maintenance fast and simple, each kit is designed for specific service tasks. Kits include

- Exchange units
- Upgraded sets of components
- Upgrade kits
- Pre packed sets of standard service parts

## Original Spare Parts in Advanced Materials

High quality standard materials together with advanced special materials for demanding applications provide

- High corrosion resistance
- Improved wear resistance
- Construction materials tailored to the application and the pumped fluid

This means

- Longer parts life time
- Longer meantime between repairs
- Reliable operation
- Less unexpected failures
- Lower life cycle costs

## Inventory Management

To complement our spare parts services Sulzer Pumps offers a full range of inventory management services to optimize parts stock and handling. Options range from a stock review with recommendations for improvement to full offsite stock management.

Benefits to customers include

- Reduced inventory costs
- Optimized stock levels
- Frees up staff from stock management
- Offsite solution releases floor space

**motralec**

4 rue Lavoisier . ZA Lavoisier . 95223 HERBLAY CEDEX  
Tel. : 01.39.97.65.10 / Fax. : 01.39.97.68.48  
Demande de prix / e-mail : [service-commercial@motralec.com](mailto:service-commercial@motralec.com)  
[www.motralec.com](http://www.motralec.com)