



**motralec**

4 rue Lavoisier . ZA Lavoisier . 95223 HERBLAY CEDEX

Tel. : 01.39.97.65.10 / Fax. : 01.39.97.68.48

Demande de prix / e-mail : [service-commercial@motralec.com](mailto:service-commercial@motralec.com)

[www.motralec.com](http://www.motralec.com)

## LPG – Pump Catalogue

A photograph of several large, cylindrical industrial storage tanks, likely for LPG, with metal ladders and pipes. The tanks are situated in an industrial facility.

**Auto Gas**

**Bottling**

**Transfer**

**Sterling Fluid Systems Group**  
[www.sterlingfluidsystems.com](http://www.sterlingfluidsystems.com)

# LPG - Pumps

## 1.1 SC 2002/5 .....2004/5 Auto gas station LPG Pump

### TECHNICAL DATA

Medium duty design ( PN 40 )  
Q<sub>max</sub> : 65 l/min  
delta p : 14 bar  
speed : 2900 rpm  
t<sub>max</sub> : 80° C  
PN : 40 bar  
Stages : 2 - 4  
mat. design : EN JS 1025  
( nodular iron GGG40.3 )  
ATEX 94/9/EC : Ex II 2 G c T1-T5

### APPLICATION

LPG - plants (propane, butane)  
Bottom off loading

### DESIGN

Sterling SIHI-side channel pumps in combination system:  
Handling gas along with the liquid - low noise pumps with  
**NPSH inducer stage** are used for problem-free pumping  
of liquids at unfavourable suction side pumping conditions.

They are also applicable for NPSHA of 0,4 – 0,65 m.

Type code:

SC 2000/5 A4 AFU 1A 0	Monoblock design
SC 2000/5 AA AFU 1A 0	Base plate design

### Casing pressure

Max. 40 bar from - 25 °C to + 80 °C  
Casing pressure = inlet pressure + delivery  
head at minimum flow.

### Please observe:

Technical rules and safety regulations.

### Drive:

By commercial electric motors, type of construction  
IM B3. and B35 for A4 design

### Flanges:

Suction branch axial, discharge branch pointing radially  
upwards. The flanges correspond to DIN 2535  
Flange design to DIN 2512 with groove and drilled to  
ANSI 150 as well as BS. Table F, is possible.

### Hydraulic:

Side channel hydraulic with NPSH inducer stage



### Bearing:

One grease-lubricated grooved ball bearing to DIN 625 and  
one liquid surrounded sleeve bearing.

### Sense of rotation:

Anti-clockwise, seen from the drive on the pump.

### Shaft sealing:

Specially for LPG: "AFU"  
Sterling standard balanced mechanical for 40 bar

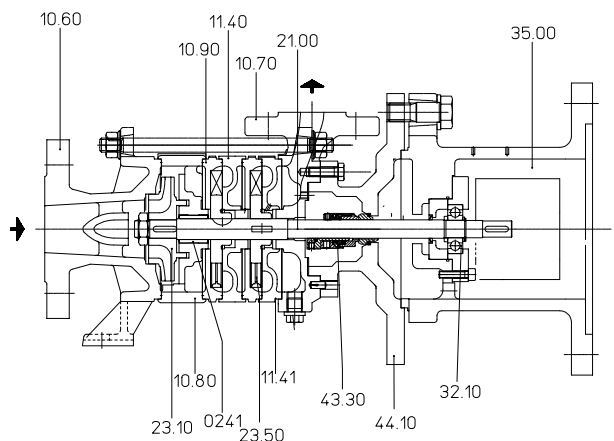

SC 2002/5 A4 AFU 1A 0 Monoblock



Car filling station with SC 2003/5

## 1.2 CEHA 3102/5 – 6108/5 CEHA 3102/7 – 6108/7

### TECHNICAL DATA

Medium duty design ( PN 40 )

$Q_{max}$	: 1 – 35 m <sup>3</sup> /h
Delivery head $_{max}$	: 354 m
Speed $_{max}$	: 1800 rpm
$t_{max}$	: 80° C
PN	: 40 bar
Stages	: 2 - 8
Mat. design	: EN JL 1040 ( cast iron GG25 ) EN JS 1025 ( nodular iron GGG40.3 )
ATEX 94/9/EC	: Ex II 2 G c T1-T5

### APPLICATION

LPG - plants (propane, butane)  
Bottom off loading  
Transfer

### DESIGN

/5 means a special for LPG Sterling SIHI-side channel pumps in combination system:

Handling gas along with the liquid - low noise pumps with

**NPSH inducer stage** are used for problem-free pumping of liquids at unfavourable suction side pumping conditions.

They are also applicable for NPSHA of 0,2 – 0,85 m.

Type code:

CEHA 3102/5 AA AFU <b>0A</b> 0	( cast iron GG25 )
CEHA 3102/5 AA AFU <b>1A</b> 0	( nodular iron GGG40.3 )

CEHA 3102/7.... Retaining stage to save service liquid and install a level controller and dry running protection

### Casing

Max. 40 bar from - 25 °C to + 80 °C( - 40°C as option)

Casing pressure = inlet pressure + delivery head at minimum flow.

### Please observe:

Technical rules and safety regulations.

### Drive:

By commercial electric motors, type of construction IM B3.

### Flanges:

Suction branch axial, discharge branch pointing radially upwards. The flanges correspond to DIN 2535

Flange design to DIN 2512 with groove and drilled to ANSI 150 as well as BS. Table F, is possible.

### Hydraulic:

Side channel hydraulic with NPSH inducer stage



### Bearing:

One grease-lubricated grooved ball bearing to DIN 625 and one liquid surrounded sleeve bearing.

### Sense of rotation:

Anti-clockwise, seen from the drive on the pump.

### Shaft sealing:

Specially for LPG: "AFU"

Sterling standard balanced mechanical for 40 bar

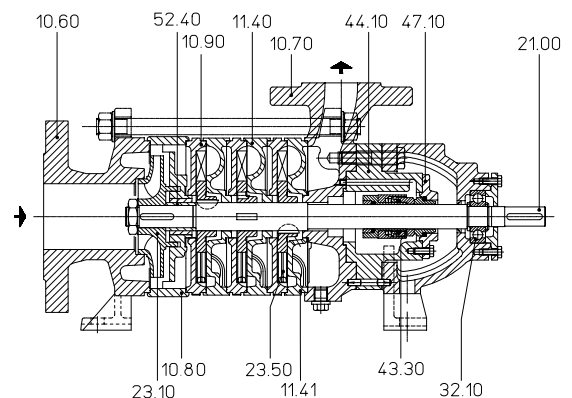

CEHA 3103/5 AA AFU 1A 0

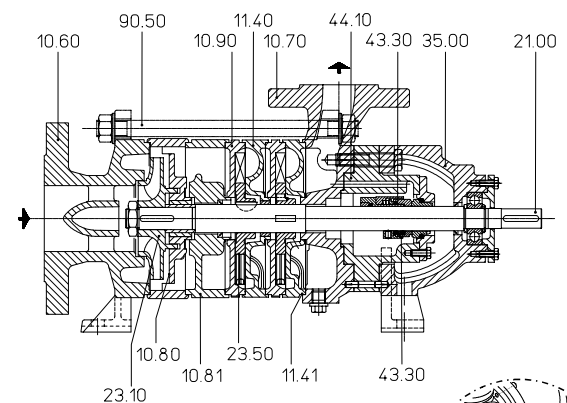

### Option:

Dry running protection and level controller

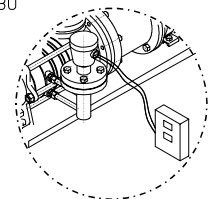

CEHA 3102/7 AA AFU 1A 0 with retaining stage

# LPG - Pumps

## 1.3 UEAA 5001 - 10010

### TECHNICAL DATA

Medium duty design ( PN 40 )  
 $Q_{max}$  : 220 m<sup>3</sup>/h  
 $\Delta p_{max}$  : 27 bar  
 $speed_{max}$  : 3400 rpm (1800 rpm)  
 $t_{max}$  : 80° C  
 PN : 40 bar (25 bar)  
 Stages : 2 - 10  
 mat. design : EN JL 1040  
                   ( nodular iron GGG40.3 )  
                   1.0619  
                   (steel cast GS C 25)  
 ATEX 94/9/EC : Ex II 2 G c T1-T5

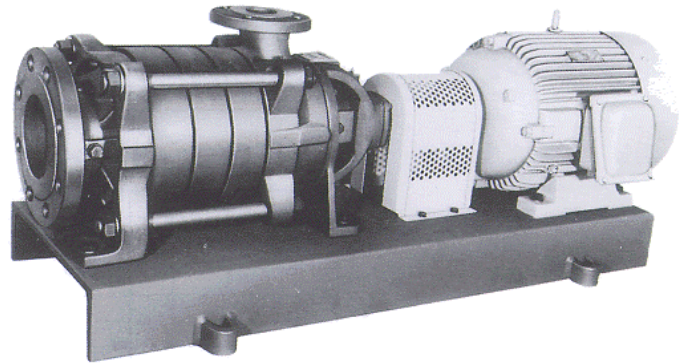

### APPLICATION

LPG - plants (propane, butane)  
 Bottom off loading  
 Transfer

### DESIGN

LPG Sterling SIHI pump in combination system. **Multistage centrifugal pump** with a **side channel hydraulic** to handling gas along with the liquid, - low noise and a special **NPSH inducer stage** are used for problem-free pumping of liquids at unfavourable suction side pumping conditions.

They are also applicable for NPSHA of 1,2 - 2,6 m.

Type code:

UEAA 6502 MA DBG 1C 1           (nodular iron GGG40.3 )  
 UEAA 6502 MA DBG 2C 1           (steel cast GS C 25)

### Bearing:

One grease-lubricated grooved ball bearing to DIN 625 and one liquid surrounded sleeve bearing.

### Sense of rotation:

Clockwise, seen from the drive on the pump.

### Shaft sealing:

Specially for LPG: "DBG"  
 Sterling standard balanced mechanical for 40 bar

### Casing

Max. 40 bar (25 bar 10000) from - 25 °C to + 80 °C  
 Casing pressure = inlet pressure + delivery head at minimum flow.

### Please observe:

Technical rules and safety regulations.

### Drive:

By commercial electric motors, type of construction IM B3.

### Flanges:

Suction franch axial, discharge branch fointing radially upwards. The flanges correspond to DIN 2535  
 Flange design to DIN 2512 with groove and drilled to ANSI 300 as well as BS. Table F, is possible.

### Hydraulic:

Multistage centrifugal pump with a side channel hydraulic to handling gas along with the liquid, - low noise and a special NPSH inducer stage.

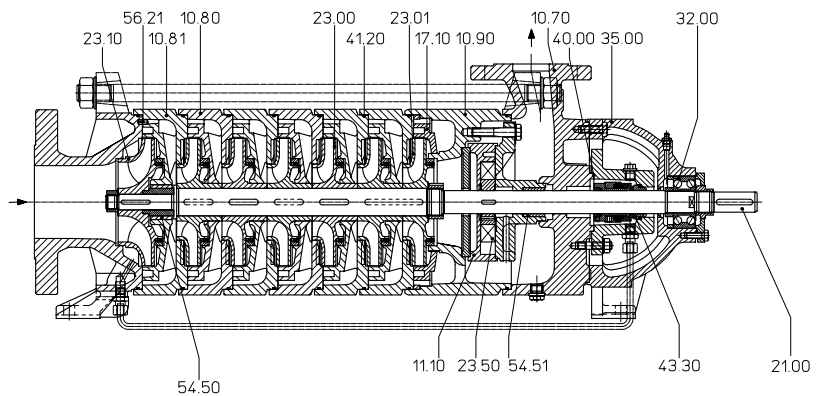

UEAA 6502 MA DBG 1C 1

## 1.4 PC 3102/7 ... 6107/7 Suction lift operation for under ground tanks

### TECHNICAL DATA

Output	:	max. 30 m <sup>3</sup> /h
Differential pressure	:	max 18 bar
Speed	:	max. 1800 rpm
Shaft sealing	:	standard mechanical seal seals mag.drive as option
Nominal pressure	:	PN 25
Tank volume	:	max. 200 m <sup>3</sup>
Suction lift	:	max 4 m
LPG	:	-100% propane -mixtures propane/butane with min. 20% propane
Temperatue	:	-25 to 80°C (-40°C option)
Flange connections	:	DIN 2501 PN 25
Mat. design	:	EN JL 1040 (cast iron GG25) EN JL 1040 (nodular iron GGG40.3)
ATEX 94/9/EC	:	Ex II 2 G c T1-T5

### APPLICATION

Loading from under ground tanks  
Transfer

### DESIGN

Sterling SIHI-side channel multistage pump plant with handling gas along with the liquid - low noise pumps with **NPSH inducer stage** are used for problem-free pumping of liquids at unfavourable suction side pumping conditions.

Type code:  
PC 3607/7 L4 NB 1A A 01 (nodular iron GGG40.3)

### Casing

Max. 40 bar from - 25 °C to + 80 °C  
Casing pressure = inlet pressure + delivery head at minimum flow.

### Please observe:

Technical rules and safety regulations.

### Drive:

By commercial electric motors, type of construction  
Flame proved IM B3. EEXE II T3  
EEXD II B T4  
EEXEe C II T4

### Flanges:

Suction flange axial, discharge flange pointing radially upwards. The flanges correspond to DIN 2535  
Flange design to DIN 2512 with groove and drilled to ANSI 300 as well as BS. Table F, is possible.

### Hydraulic:

Side channel hydraulic with NPSH inducer stage

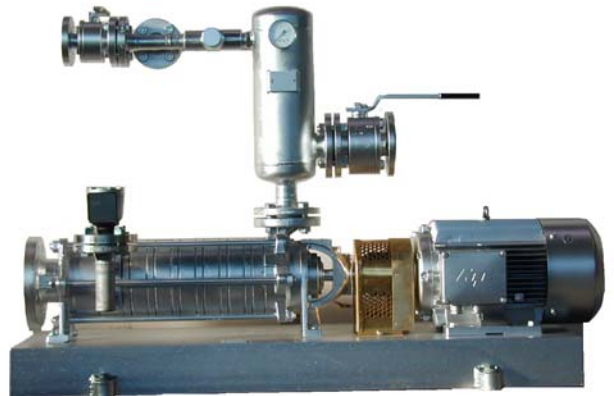

### Bearing:

One grease-lubricated grooved ball bearing to DIN 625 and one liquid surrounded sleeve bearing.

### Sense of rotation:

Anti clockwise, seen from the drive on the pump.

### Shaft sealing:

Specially for LPG: AFU"  
Sterling standard balanced mechanical for 40 bar



PC 3605/7 L4 NB 1A A 01 for car fillig

# LPG - Pumps

## 1.5 CEBA 2002 - 2004

Suction lift operation for under ground tanks

### TECHNICAL DATA

Output	: max. 65 l/min
Differential pressure	: max. 14 bar
Speed:	: max. 2900 rpm
Temperature	: max. - 40 °C to + 60 °C
Casing pressure	: PN 40
Shaft sealing	: Sealless magnetic coupling
Flange connection	: DIN 2501 PN 40 ( ANSI 300 as option )
Direction of rotation	: Anti-clockwise when seen from the drive end
Casing material	: EN JS 1025 ( nodular iron GGG40.3 )
ATEX 94/9/EC	: Ex II 2 G c T1-T5

### APPLICATION

Vertical, extended tank pump essentially for handling liquids that are either boiling or stored at their vapour pressure. Particularly suited to AutoGas filling stations.

One of the primary features of this side-channel type of pump is the special suction impeller that requires extremely low levels of NPSH. CEB pumps have been specifically designed for use with Liquefied Petroleum Gas and other liquefied gases.

### DESIGN

Sterling-SIHI side channel units are a low noise design of combination pump. They are ideal for pumping liquids that are stored at their boiling point, have a degree of entrained gas, or very low NPSH conditions. The vertical tank pump has been designed in order to enable retro-fitting into most common tanks. Moreover, the dimensions are such that the unit can be used to replace submersible designs of pump. Although the pump can be supplied in other lengths, the standard size is between 1.3 -& 3.0 m.

### CONSTRUCTION

#### Casing pressure:

Max. 40 bar from -40°C to +60°C.

#### Please observe:

Technical and safety regulations that apply to installation.  
Casing pressure = inlet pressure + delivery pressure at minimum output.

#### Flange position:

Tank flange vertical, discharge flange horizontal.

#### Connection:

Flange design to DIN 2534 / PN40 or DIN 2512 with groove. And spring. Other drillings available upon request. ANSI as well is possible

#### Hydraulics:

Side channel hydraulic with NPSH inducer stage.



#### Bearing:

Two product lubricated SiC sleeve bearings with plus additional intermediate bearings throughout the extended shaft.

#### Shaft sealing:

Sealless/Magnetic drive. Power transmission effected by magnetic coupling. Importantly, this is a modular design adapted from our extensive range of sealless pumps.

#### Casing seal:

The static casing seals are made from seal liquid

#### Drive:

By standard electric motor, IM V1 or B5.

## Auto gas pump solutions:

For auto gas station Sterling SIHI can offer thee different solutions:

- 1.1 Bottom-off loading, tank above surface of the earth, pump below tank, SC, CEH.
- 1.2 Top-off loading, underground tank with PC unit above surface of the earth
- 1.2 Top-off loading, underground tank with internal tank pump, motor outside of the tank, CEB

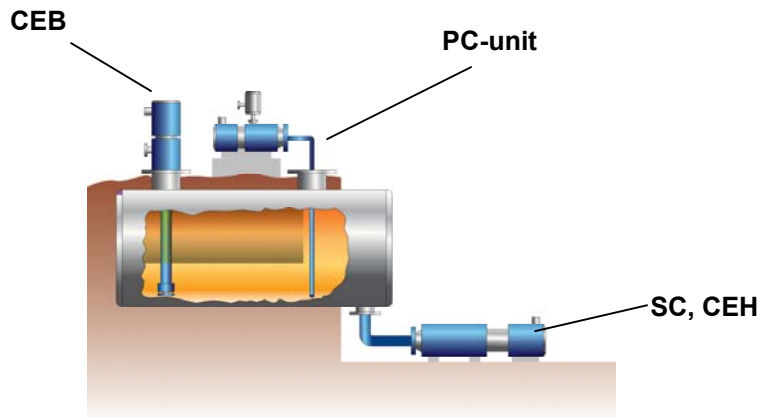

Generally to select a pump two things has to be considered :

Max start pressure during start phase	:	app: 7 – 9 bar
Filling pressure during filling	:	app: 4 – 6 bar
Flow rate during filling	:	15 to 25 l/min

The filling pressure is depending of the smallest nozzle orifice diameter and car tank construction. In hot season periods is a short start pressure of 7 to 9 bar requierd, to calculate the flow rate a lower filling pressure of 4 to 6 bar is to consider.

**SC 2003/5 A4 AFU 1A 0**  
**CEHA 3606/5 AA AFU 1A 0**

### Requested sizes:

Standard execution:

SC 2003/5	2,5 / 3,0 kW Motor	for 1 Dispenser
-----------	--------------------	-----------------

Industrial execution:

CEHA 3105/5	3,6 / 4,0 kW Motor	for 1 Dispenser
CEHA 3606/5	3,6 / 4,0 kW Motor	for 2 Dispenser
CEHA 3607/5	5,0 / 5,5 kW Motor	for 3 Dispenser
CEHA 4105/5	5,5 / 6,8 kW Motor	for 4 Dispenser
CEHA 4106/5	6,8 / 7,5 kW Motor	for 5 Dispenser
CEHA 4107/5	6,8 / 7,5 kW Motor	for 6 Dispenser

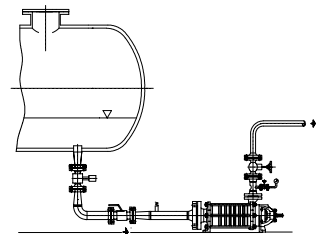

# Auto Gas

speed = 2900 rpm

sp. gr. = 0,56 kg/dm<sup>3</sup>

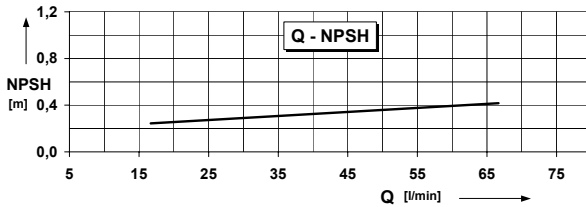
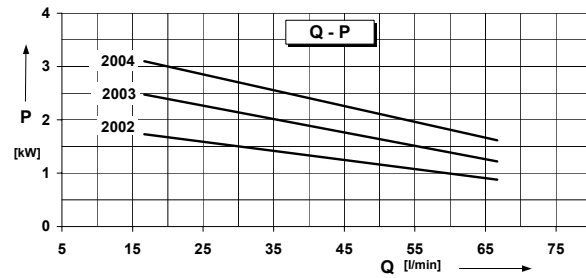
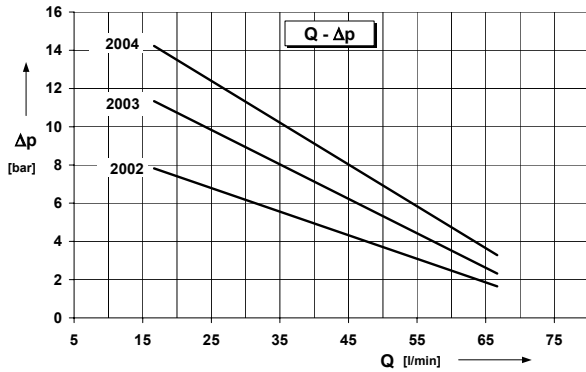

speed = 1450 rpm

sp. gr. = 0,56 kg/dm<sup>3</sup>

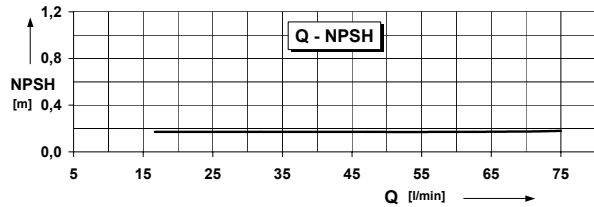
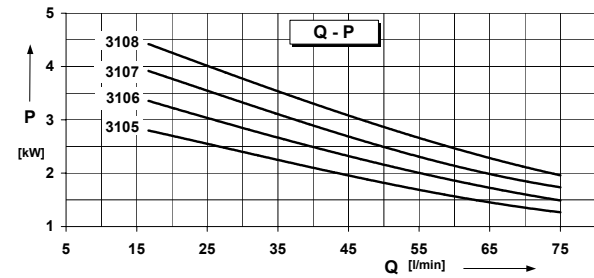
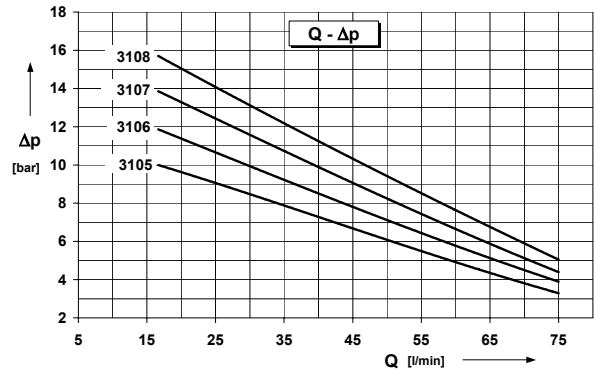

speed = 1450 rpm

sp. gr. = 0,56 kg/dm<sup>3</sup>

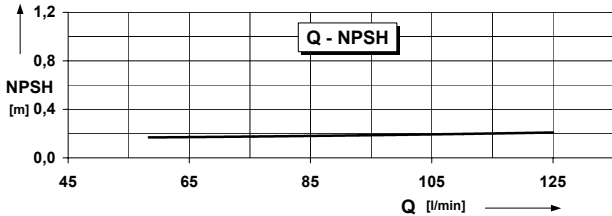
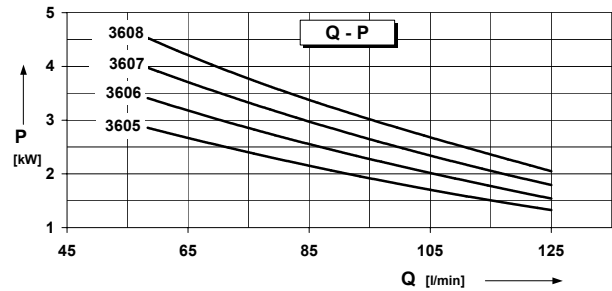
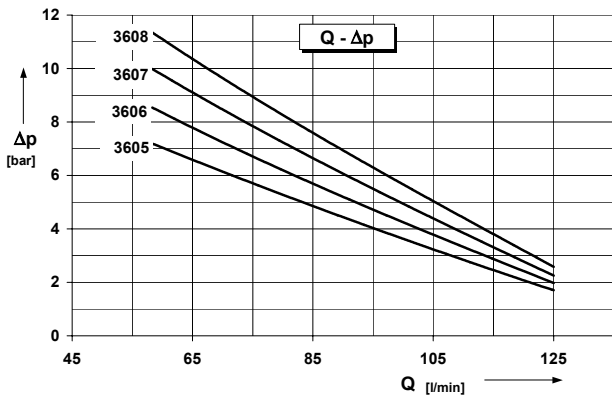

speed = 1450 rpm

sp. gr. = 0,56 kg/dm<sup>3</sup>

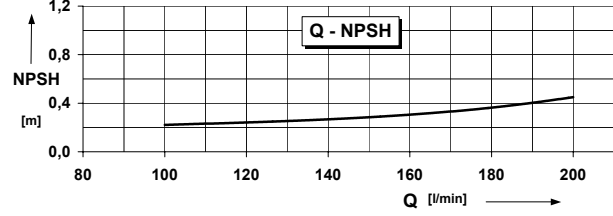
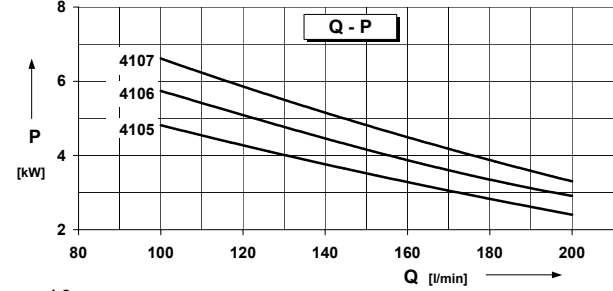
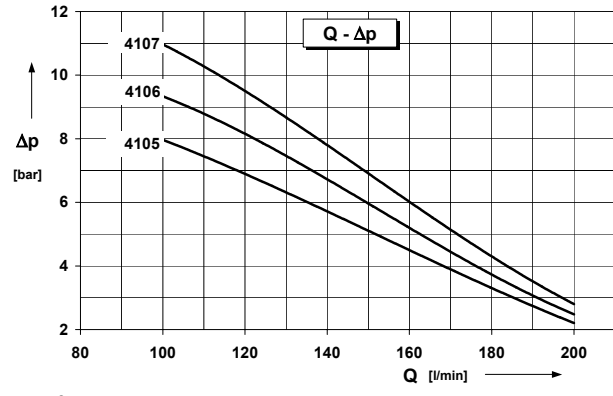

## Underground tanks 1 to 6 dispenser

PC 3105/7 - 4107/7  
CEBA 2002 - 2004

### Suction lift operation for under ground tanks

Safety regulations, relating to minimum safe distances, coupled to a physical lack of site space require the installation of under-ground LPG tanks. Discharge is therefore only possible via the top flange. The Sterling PC plant and CEBA tank pump is a top mounted pump system. The hole PC system or only the motor for the CEBA is located outside of the tank. The primary benefit being that there is no maintainable items such as electric motor or mechanical seals within the sealed & pressurised LPG vessel. The CEBA is equipped with sealles magnetic coupling, free of maintenance.

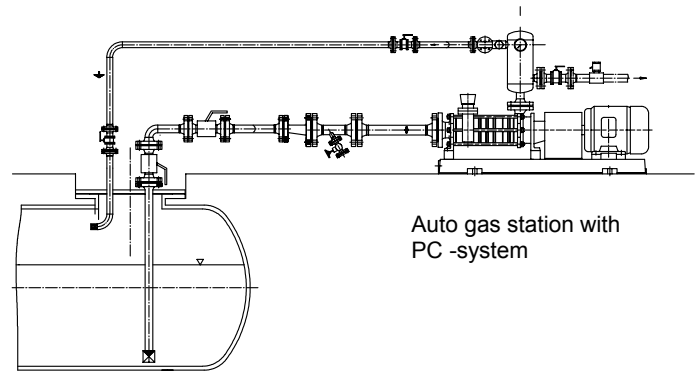

Auto gas station with  
PC -system

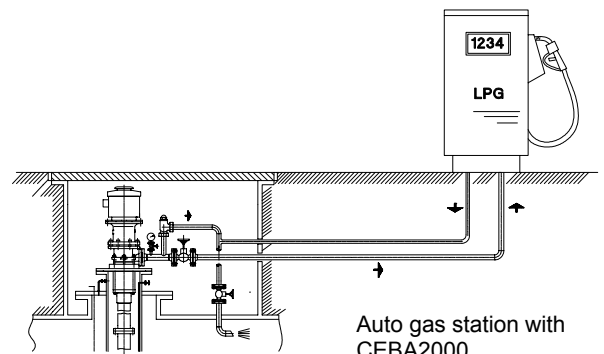

Auto gas station with  
CEBA2000

### Requested sizes:

PC 3605/7 A4 MB 0A A 02  
PC 3605/7 A4 MK 0A A 02

### Motor .

for 1 Dispenser 4,0 kW EEXd II B T4  
for 1 Dispenser 3,6 kW EEXe II T3

PC 3606/7 A4 NB 0A A 01  
PC 3606/7 A4 NK 0A A 01

for 2 Dispenser 5,5 kW EEXd II BT4  
for 2 Dispenser 5,0 kW EEXe II T3

PC 3607/7 A4 NB 0A A 01  
PC 3607/7 A4 NK 0A A 01

for 3 Dispenser 5,5 kW EEXd II B T4  
for 3 Dispenser 5,0 kW EEXd II T3

PC 4105/7 A4 PB0A A 01  
PC 4105/7 A4 PK0A A 01

for 4 Dispenser 7,5 kW EEXd II BT4  
for 4 Dispenser 6,8 kW EEXe II T3

PC 4106/7 A4 PB0A A 01  
PC 4106/7 A4 PK0A A 01

for 5 Dispenser 7,5 kW EEXd II BT4  
for 5 Dispenser 6,8 kW EEXe II T3

PC 4107/7 A4 PB 0A A 01  
PC 4107/7 A4 PK 0A A 01

for 6 dispenser 7,5 kW EEXd II B T4  
for 6 dispenser 6,8 kW EEXe II T3

### Tank pump CEBA 2000

CEBA 2003 .....  
CEBA 2003 .....

for 1 Dispenser 3,0 kW EEXd II B T4  
for 1 Dispenser 2,5 kW EEXe II T3

CEBA 2004 .....  
CEBA 2004 .....

for 2 Dispenser 3,0 kW EEXd II B T4  
for 2 Dispenser 3,3 kW EEXe II T3

# Auto gas

speed = 1450 rpm

sp. gr. = 0,56 kg/dm<sup>3</sup>

## PC 3600/7

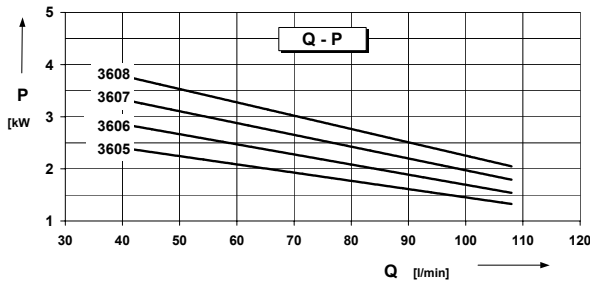
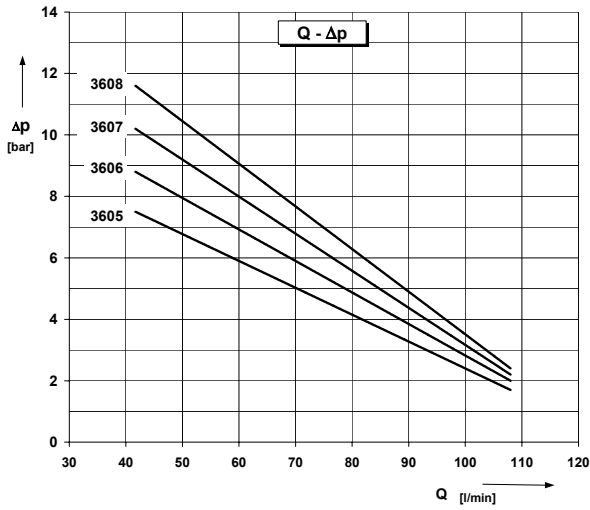

speed = 1450 rpm

sp. gr. = 0,56 kg/dm<sup>3</sup>

## PC 4100/7

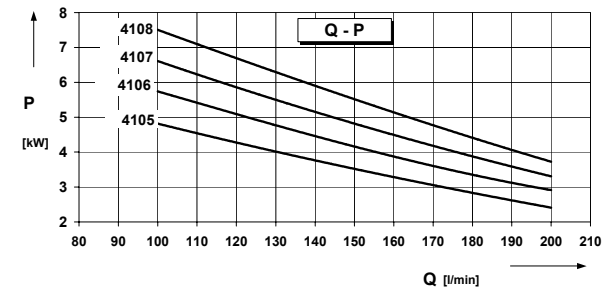
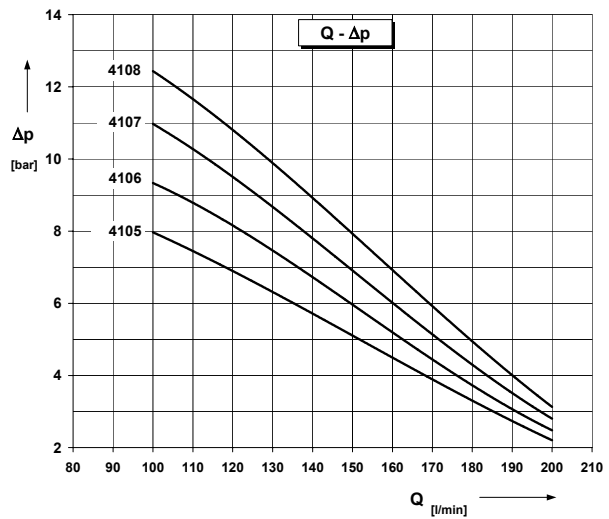

## Tank pump CEBA 2000

speed = 2900 rpm, sp. gr. = 0,56 kg/dm<sup>3</sup>

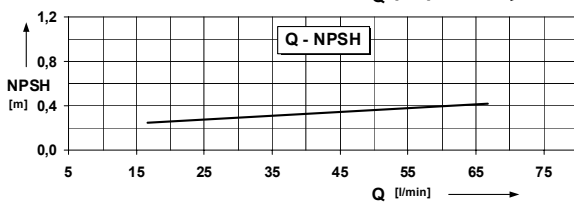
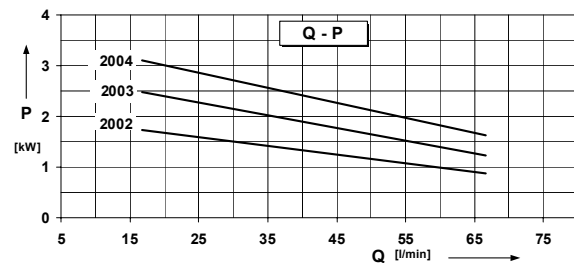
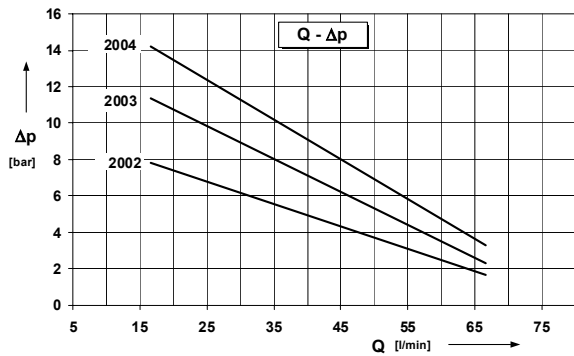

## Calculation of pump size

**CEHA 3106/5 – 6108/5**  
**UEAA 5005 – 100010**  
**PC 3605/7 – 6107/7**

### Generally :

The nominal output rating can be found in the capacity curve of a filling carousel for LPG cylinders. This nominal output rating, with regard to a constant filling pressure, should be increased by an additional, by-pass quantity led back to the filling tank via a pressure sustaining valve. The additional quantity is normally from 20 to 50 %, depending on the size of the filling system. The differential pressure to be generated by the pump depends on the frictional characteristics (system curve) of the LPG plant and the flow rate.

Whilst the static head may often be neglected, the flow losses

(dynamic head) of the components in the system can be calculated accurately with the aid of standard tables and empirical values. Uncertainty often arises when calculating the system head, which in LPG plants results mainly from pressure differences are highly dependent upon temperature changes. The seasonal temperature changes and thus the change in the pressure differential must also be considered especially at the discharge side.

The pressure difference can be determined by means of the vapour pressure curve for the media being pumped. The use of the pressure gradient of the liquefied gas could also be used. This pressure gradient indicates the pressure change per °C and guarantees a fast and accurate calculation of the differential pressure during the design stage. However it must be realized that, if extreme factors are taken into consideration, the resultant selection will be an oversized pump. Thus the high cost of both the pump and the operation under the partial load, will produce an uneconomic solution and unfavourable operating conditions.

### Pump selection:

Cylinder	:	11,8 kg		
Cylinder per hour	:	750 1/ h		
Density	:	0,56 kg/l estimated		
Flow	:	(11,8 kg /0,560 kg/l) 750 1/h	=	15.804 l/h = 15,8 m3/h

For carousel is a constant by pass flow of 20 to 50 % recommend to compensate pressure fluctuations and pump wear.

Result of Q = 15,8 m3/h x ( 1,2 to 1,5 )

Requested flow	:	Q = 19,0 to 23,7 m3/h
Filling pressure	:	13 to 17 bar
Vapour pressure normally	:	5 bar
Requested pump differential pressure	:	8 to 12 bar

### Selected pump:

Q = 19,5 to 23,7m3/h  
p = 12 to 15 bar

**CEHA 6107/5 AA AFU 0A 0**

P = 22 to 25,5 kW



## CEHA 3105/5 - 6108/5

speed = 1450 rpm

sp. gr. = 0,56 kg/dm<sup>3</sup>

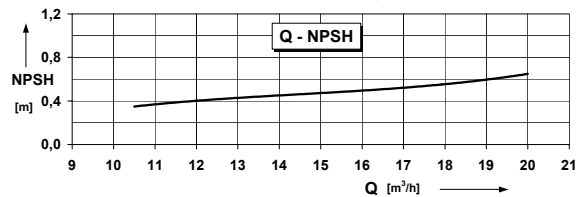
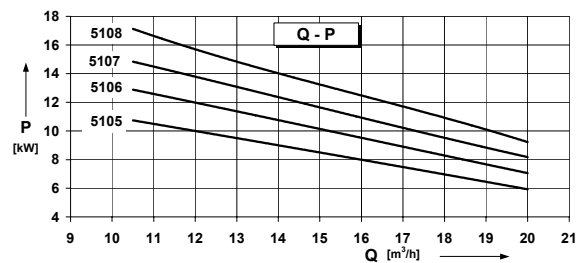
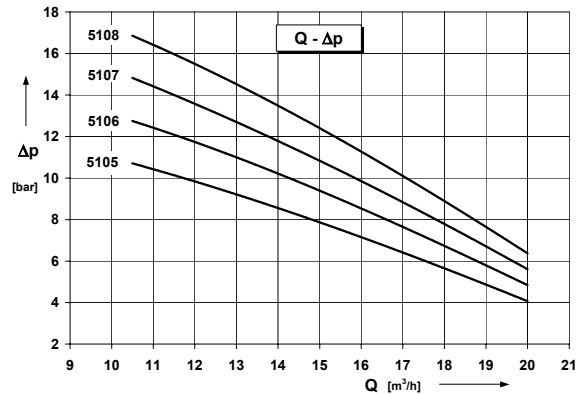
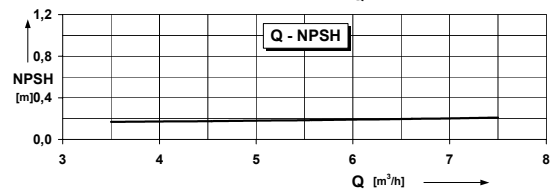
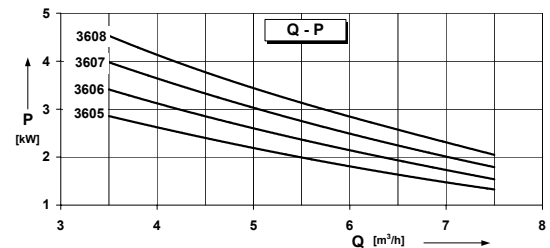
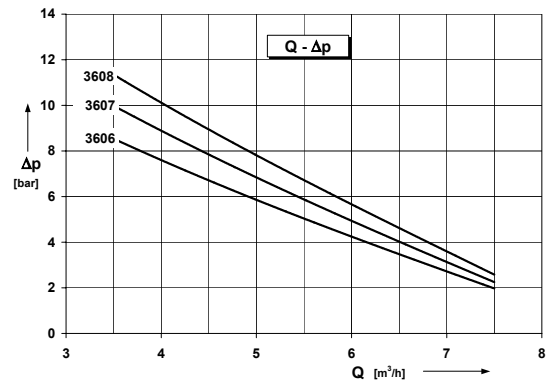
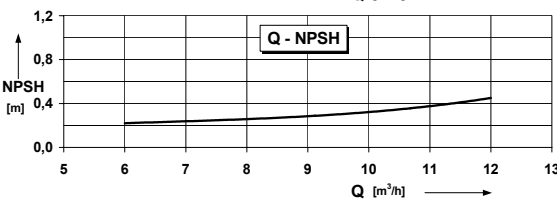
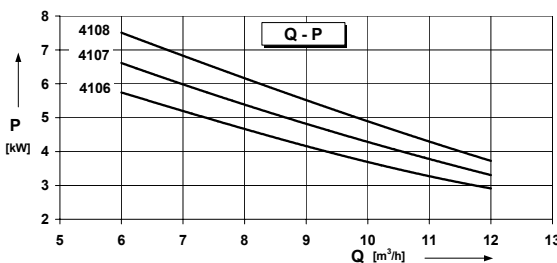
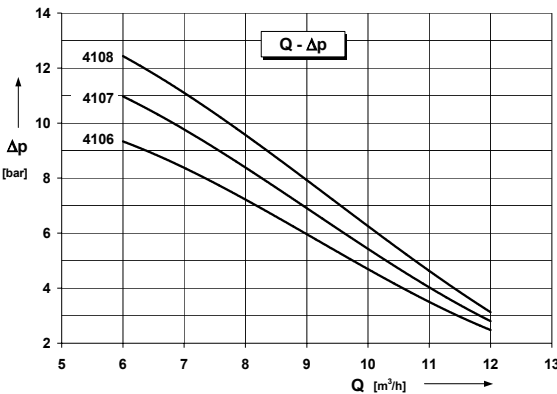
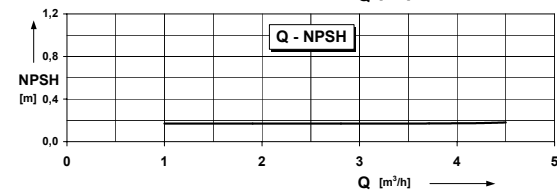
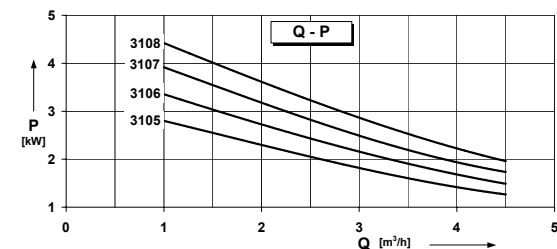
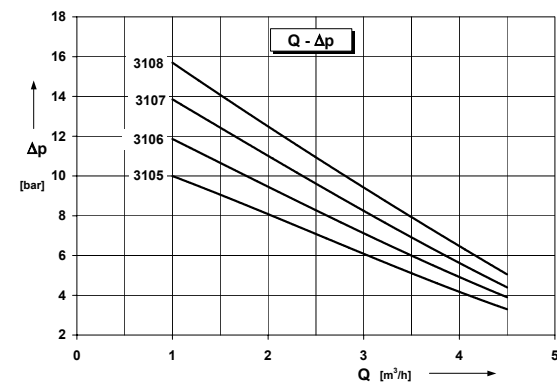

# Bottle filling

speed = 1450 rpm

sp. gr. = 0,56 kg/dm<sup>3</sup>

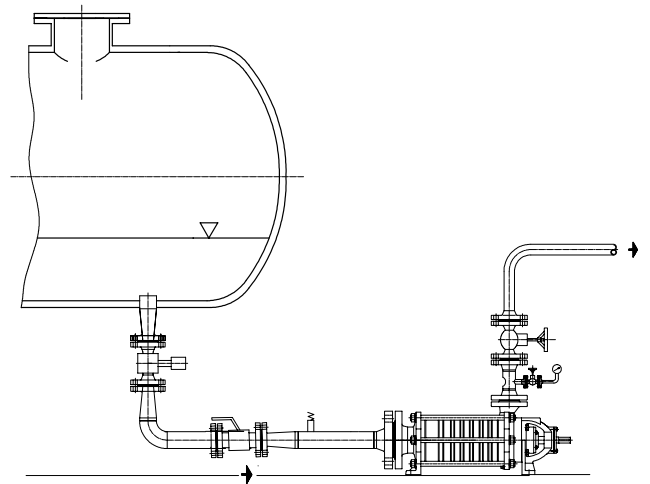
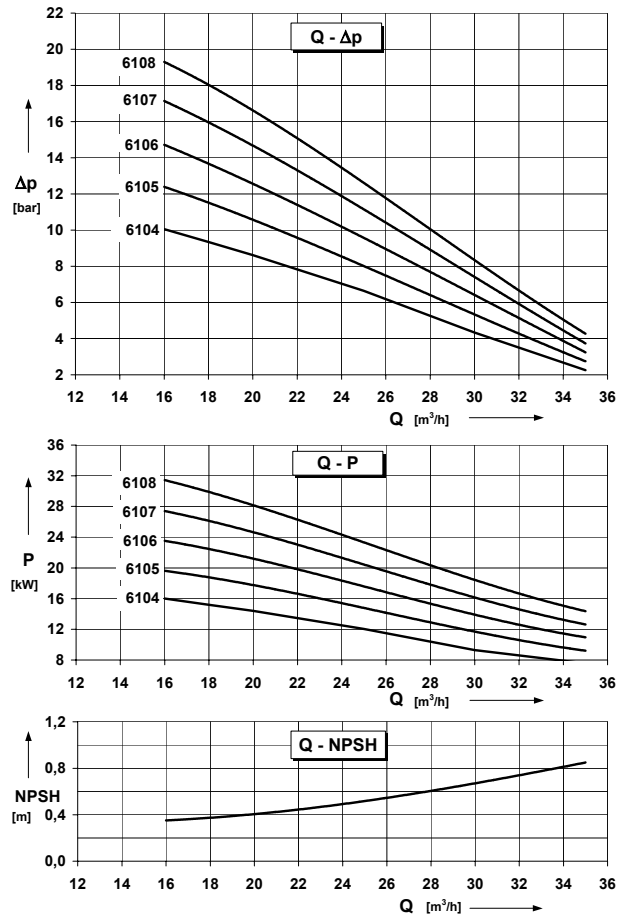

CEHA and UEAA installation over ground

## UEAA 5005 - 6505

speed = 2900 rpm

sp. gr. = 0,56 kg/dm<sup>3</sup>

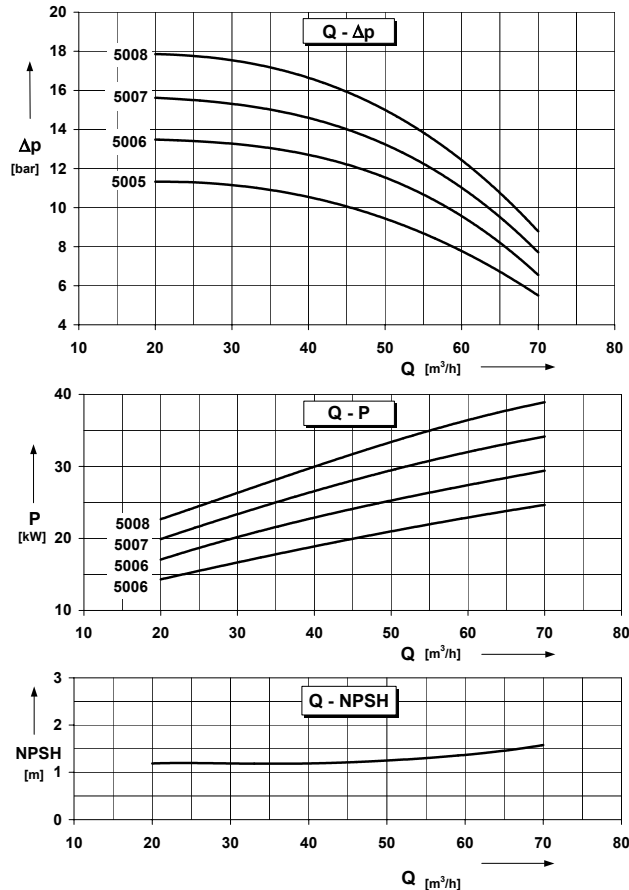

speed = 2900 rpm

sp. gr. = 0,56 kg/dm<sup>3</sup>

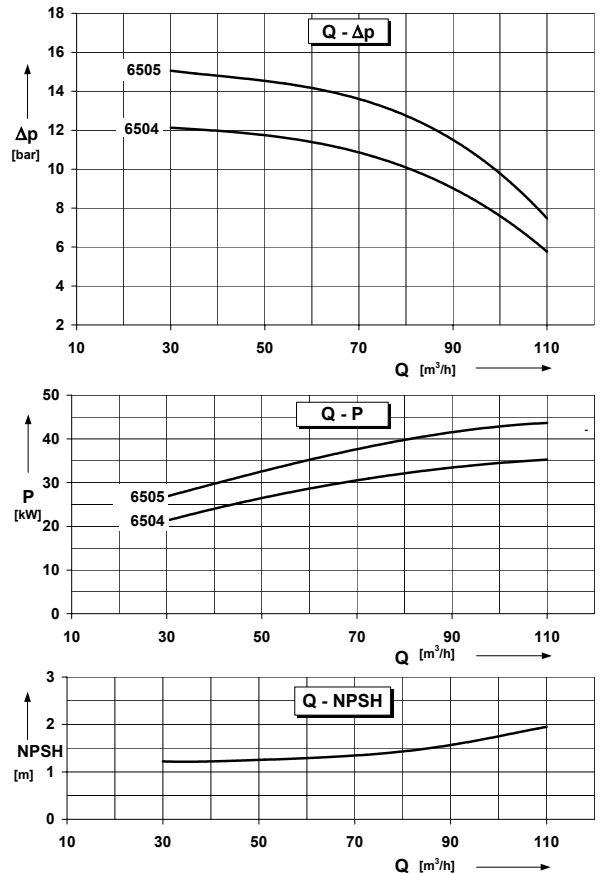

## UEAA 6506 - 10010

speed = 2900 rpm

sp. gr. = 0,56 kg/dm<sup>3</sup>

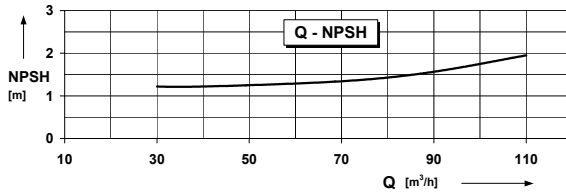
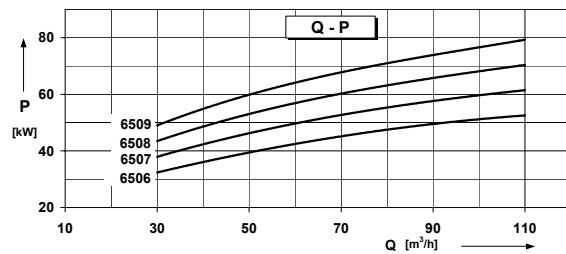
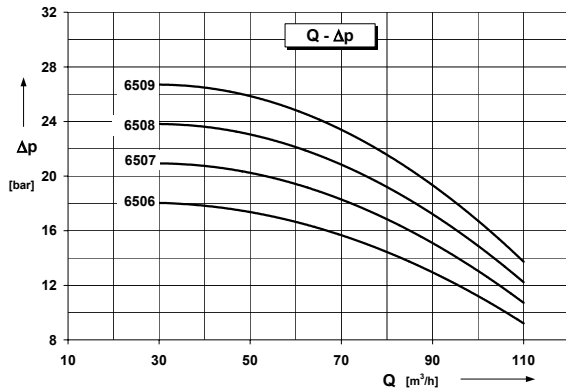

speed = 2900 rpm

sp. gr. = 0,56 kg/dm<sup>3</sup>

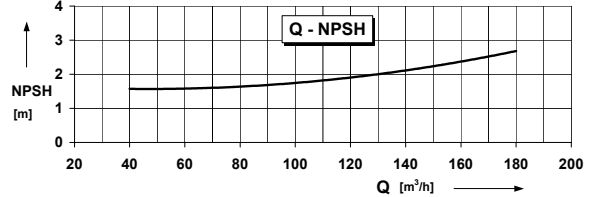
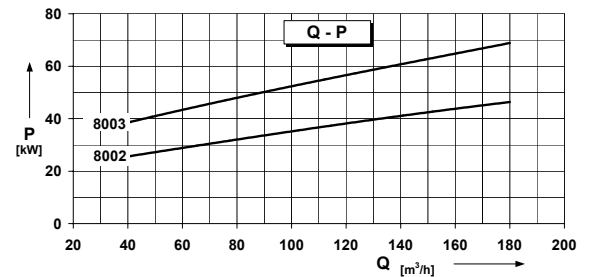
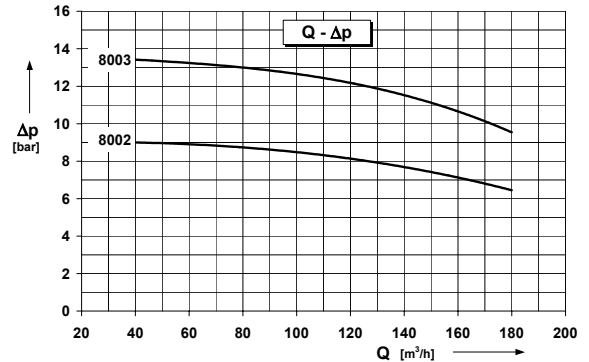

speed = 1450 rpm

sp. gr. = 0,56 kg/dm<sup>3</sup>

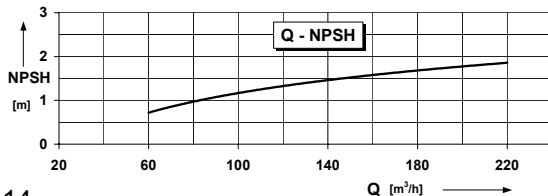
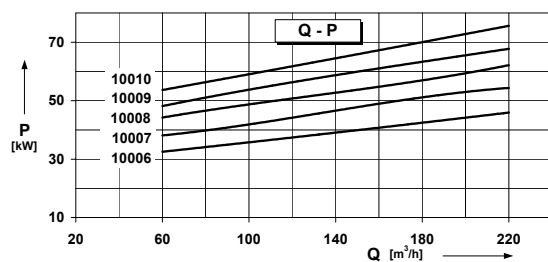
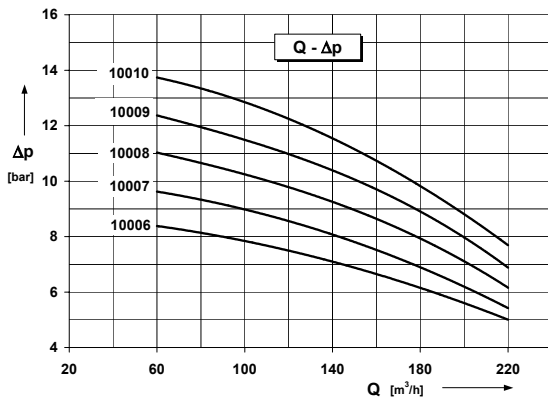

### Correction different density:

For instance : LPG with 0,52 kg/l  
CEHA 5106/5  
Q = 11,5 m<sup>3</sup>/h  
P = 12 bar  
P = 12,3 kW

$$p_{\text{new}} = 12 \text{ bar} \times (0,56/0,52)$$

11,1 bar

$$P_{\text{new}} = 12,3 \text{ kW} \times (0,56/0,52)$$

11,4 kW

$$Q_{\text{new}} = Q = 11,5 \text{ m}^3/\text{h}$$

## PC 3605 – 6107 for underground tanks

speed = 1450 rpm

sp. gr. = 0,56 kg/dm<sup>3</sup>

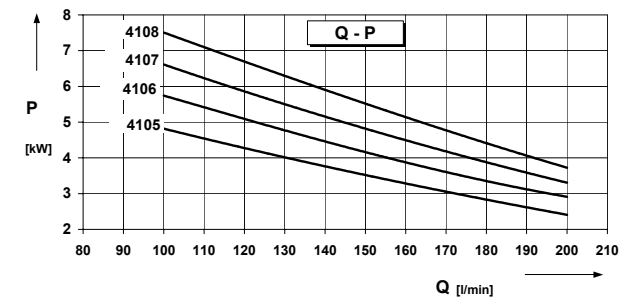
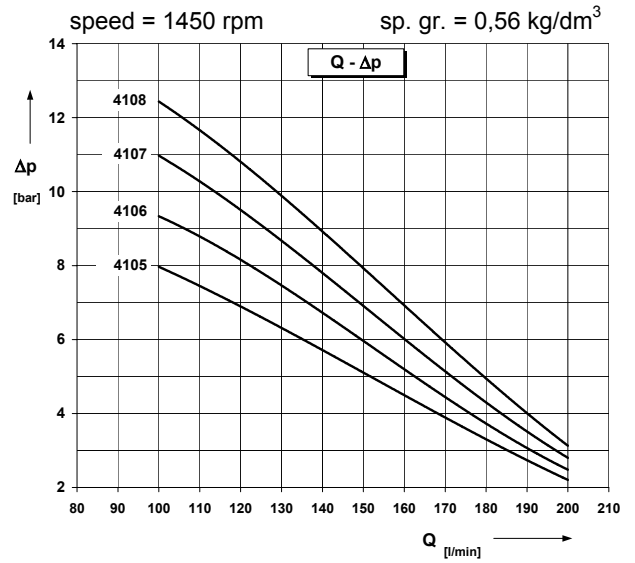
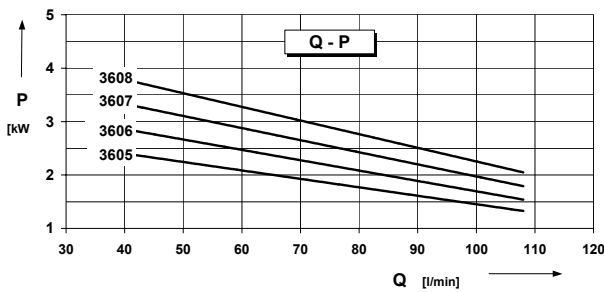
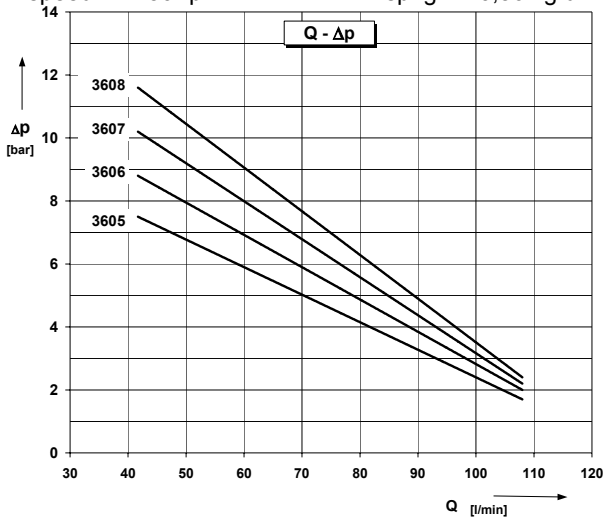

speed = 1450 rpm

sp. gr. = 0,56 kg/dm<sup>3</sup>

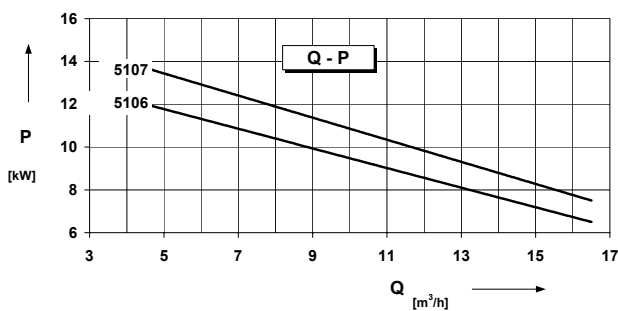
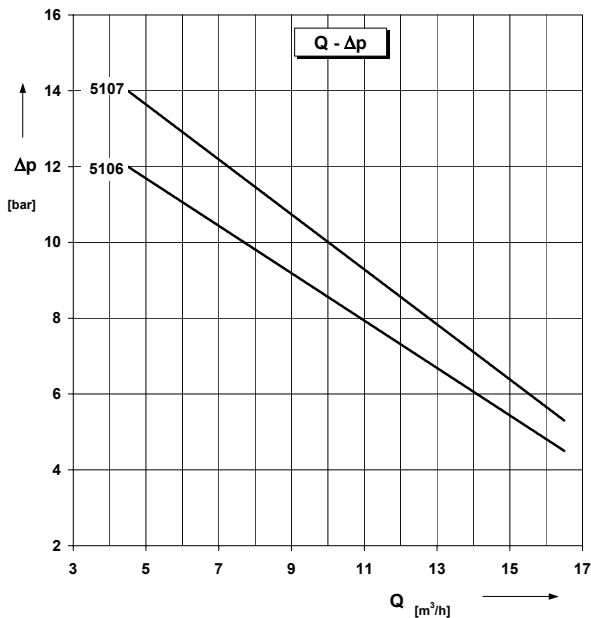

speed = 1450 rpm

sp. gr. = 0,56 kg/dm<sup>3</sup>

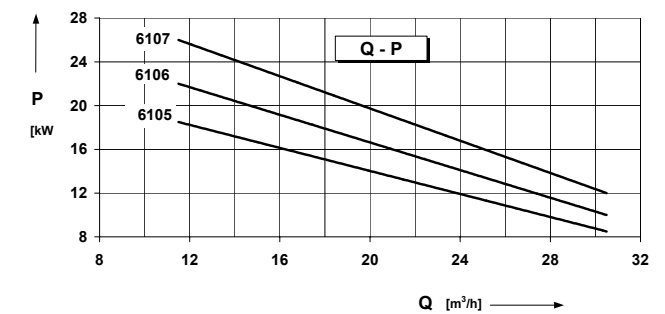
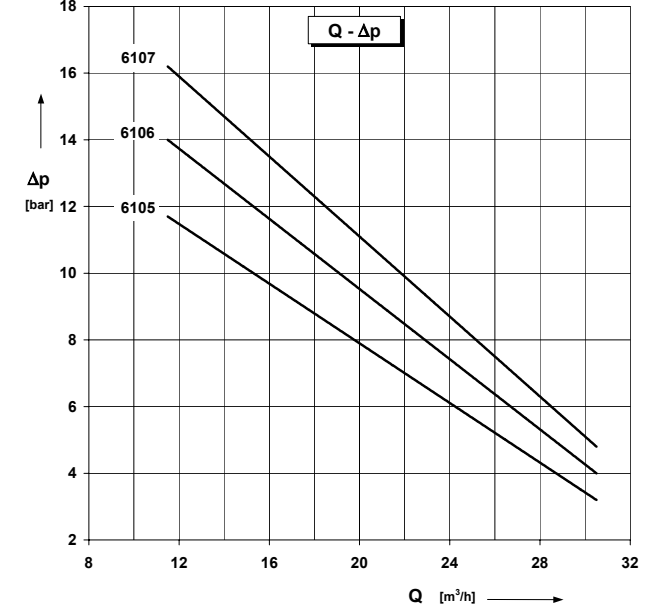

# LPG Transfer

## Selection of pump size

CEHA 3102/5 – 6108/5  
UEAA 5001 – 100010

### Rating and aspects of installation :

Pumps can be selected in accordance with the characteristic curves. Specific data, especially with regard to the required motor, will be given in our quotation.

When selecting a pump size, it must always be borne in mind that vapour-free inflow can not always be guaranteed. In practice, it is always very important to design an installation in accordance with the state of the art (e.g. see installation drawing below) in order to minimize vaporisation and headlosses. If not, some safety factors need to be incorporated in the determination of the pump design.



### Aspects on installation (general)

1. The suction pipes must be configured such that there is a minimum of resistance. There should be no filters etc. which could impact high frictional losses and hinder the flow to the pump.
2. The minimum liquid tank level must consider flow resistance of the suction pipe the required NPSH of the pump.
3. Bypass pipes from discharge side to inlet or suction side are not allowed. The bypass backflow from the relief valve must be fed back to the storage tank.
4. If one pump has to fill several tanks with different LPG mixtures at different vapour pressures, efficient non-return valves or other suitable shut-off devices are required at the discharge side to avoid any service liquid blowing out during the change-over process.
5. Required differential pressure minimum:
  - 1 – 3 bar if a vapour return line is connected between tanks.
  - 3 - 5 bar if no vapour return line is installed.
  - More than 5 bar in special cases, high temperature difference, high pipe resistant etc..
6. If more than one pump are connected with one tank a special header with right dimensions can distribute the fluid free of vapour.

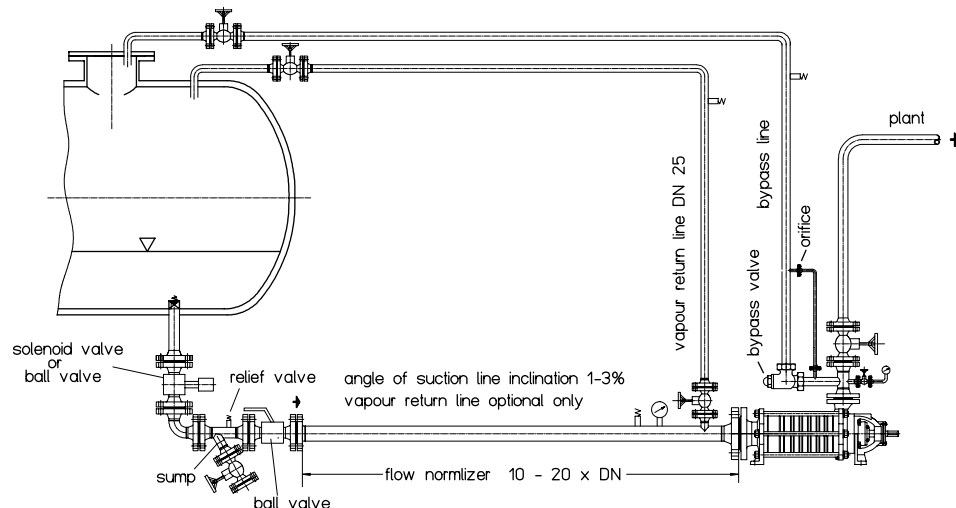

## CEHA 3102/5 - 6108/5

speed = 1450 rpm

sp. gr. = 0,56 kg/dm<sup>3</sup>

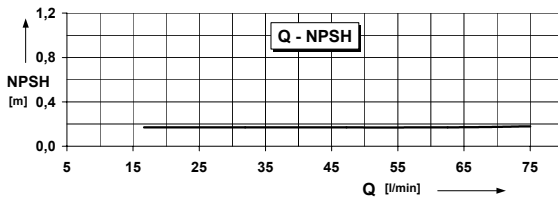
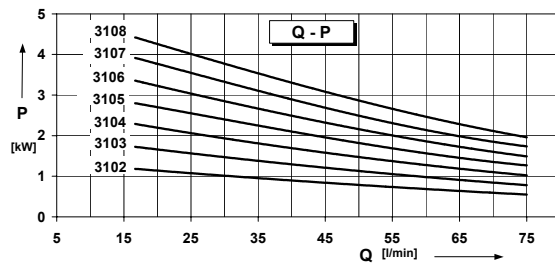
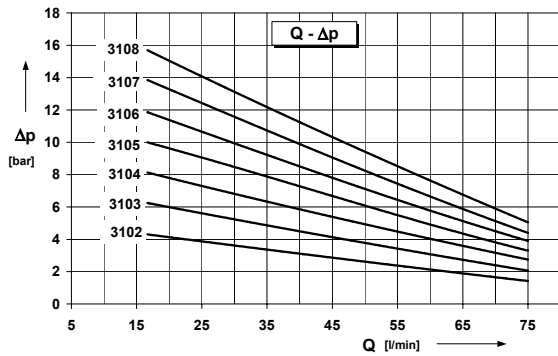

speed = 1450 rpm

sp. gr. = 0,56 kg/dm<sup>3</sup>

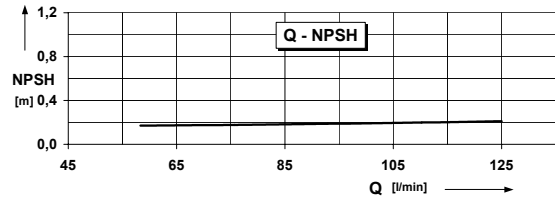
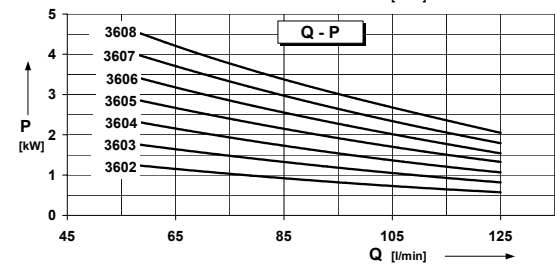
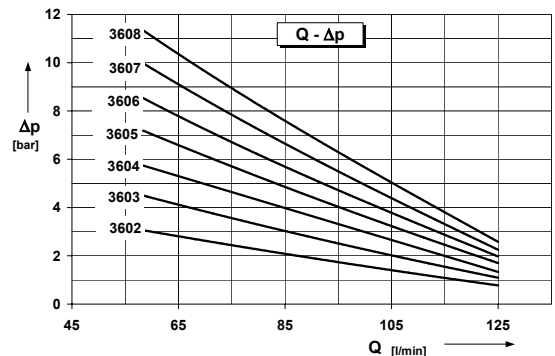

speed = 1450 rpm

sp. gr. = 0,56 kg/dm<sup>3</sup>

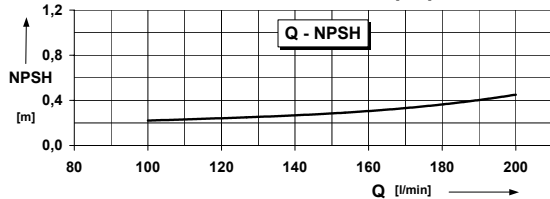
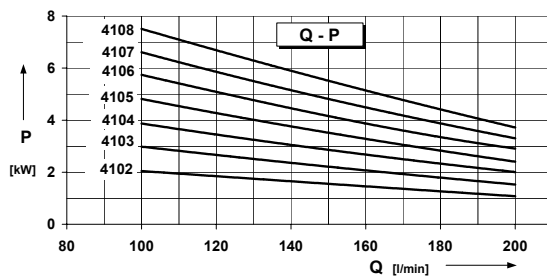
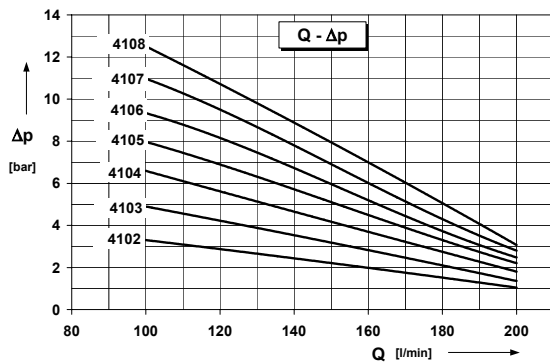

speed = 1450 rpm

sp. gr. = 0,56 kg/dm<sup>3</sup>

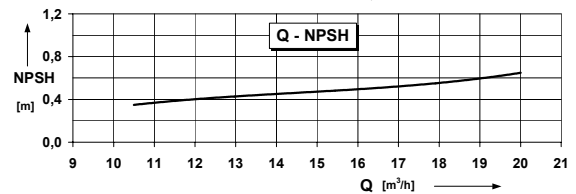
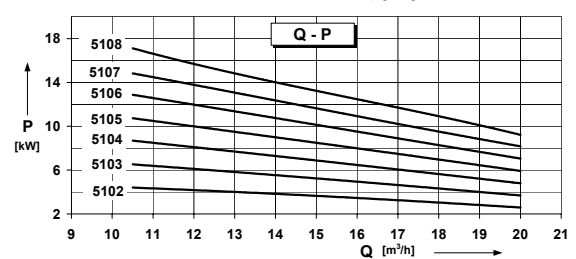
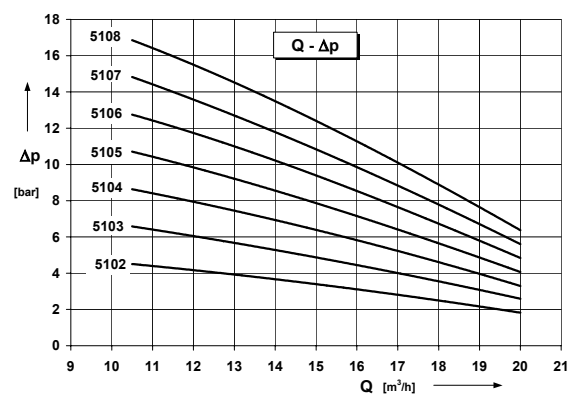

# LPG Transfer

## CEHA 6102 - 6108

speed = 1450 rpm

sp. gr. = 0,56 kg/dm<sup>3</sup>

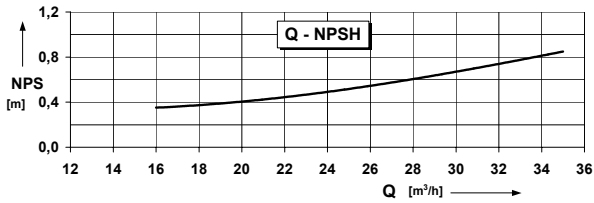
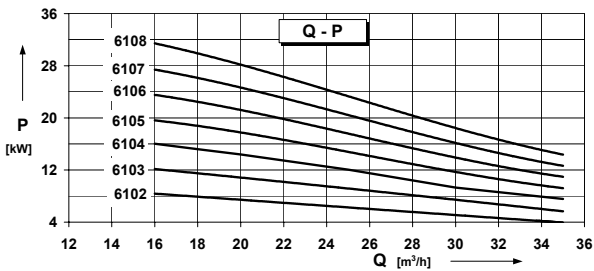
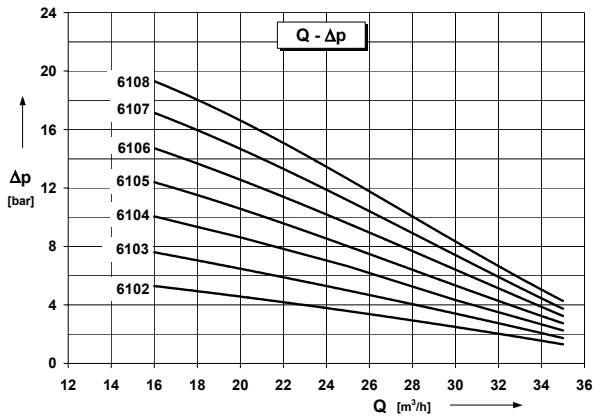

## UEAA 5001 - 10010

speed = 2900 rpm

sp. gr. = 0,56 kg/dm<sup>3</sup>

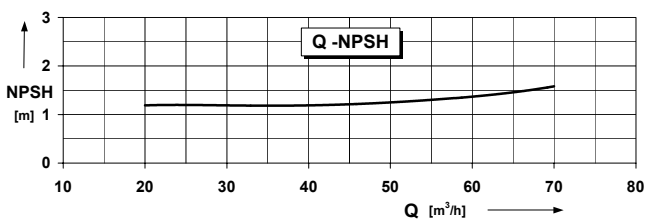
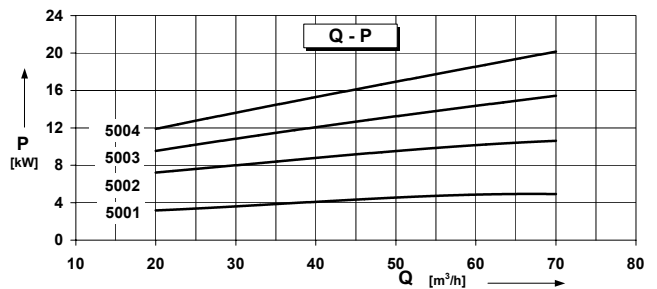
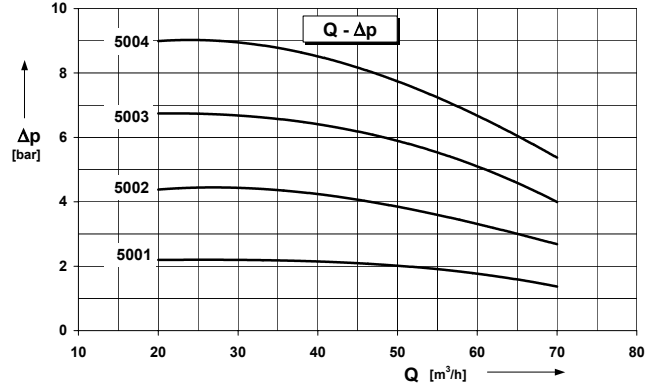

speed = 2900 rpm

sp. gr. = 0,56 kg/dm<sup>3</sup>

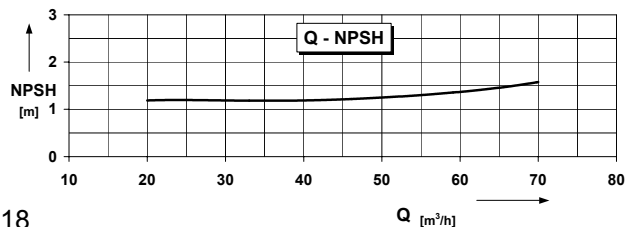
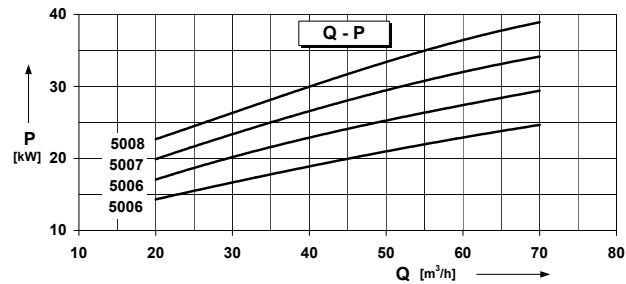
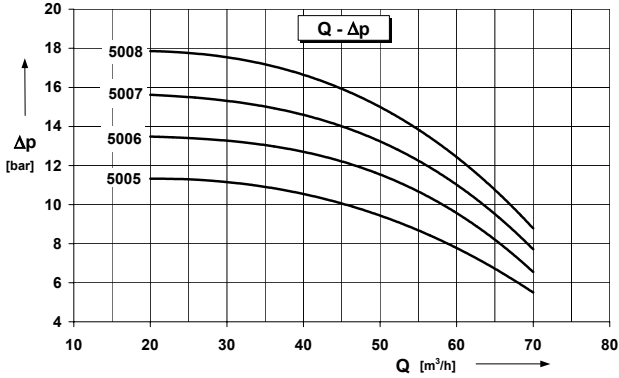

speed = 2900 rpm

sp. gr. = 0,56 kg/dm<sup>3</sup>

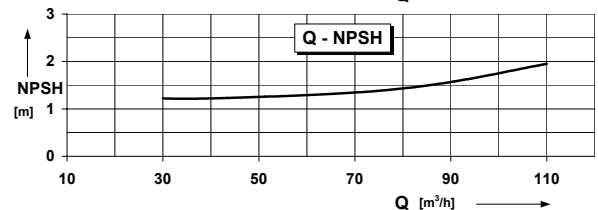
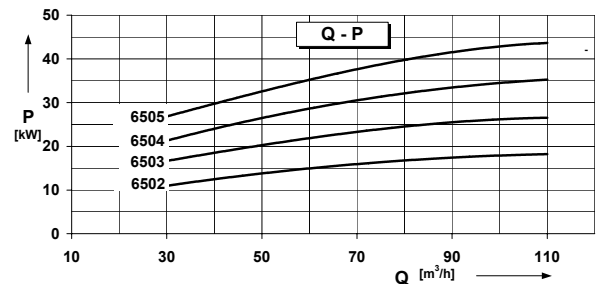
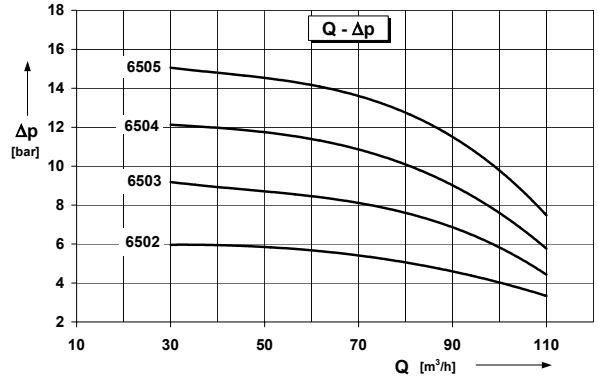

**UEAA 6506 - 10010**

speed = 2900 rpm

sp. gr. = 0,56 kg/dm<sup>3</sup>

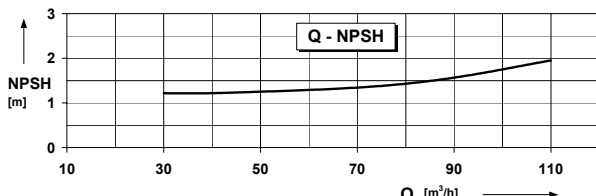
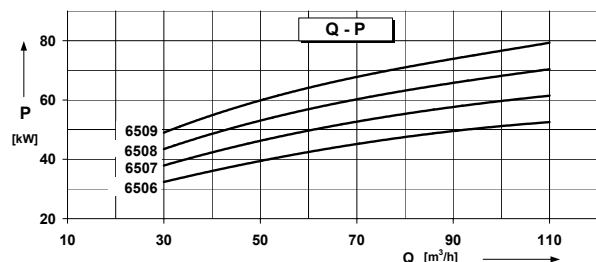
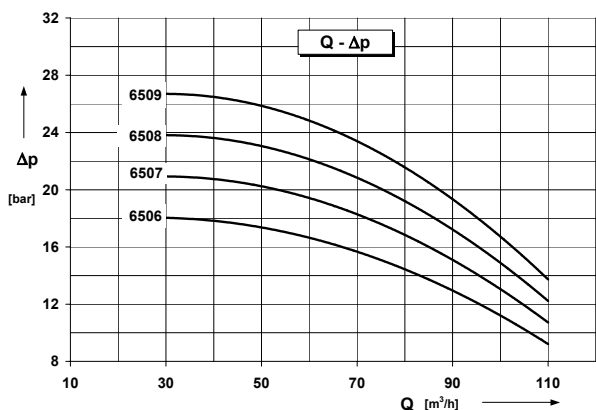

speed = 1450 rpm

sp. gr. = 0,56 kg/dm<sup>3</sup>

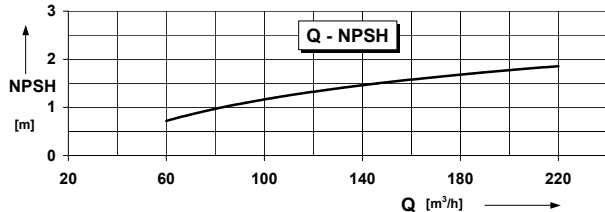
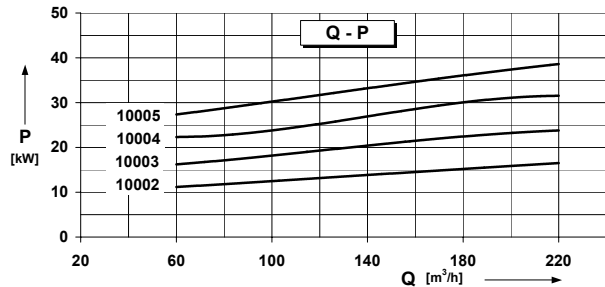
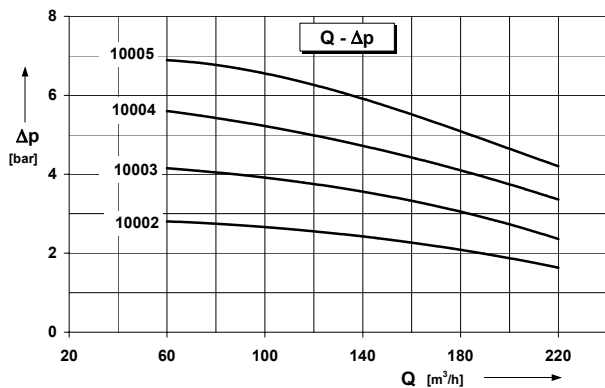

speed = 2900 rpm

sp. gr. = 0,56 kg/dm<sup>3</sup>

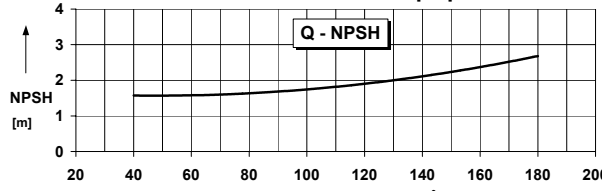
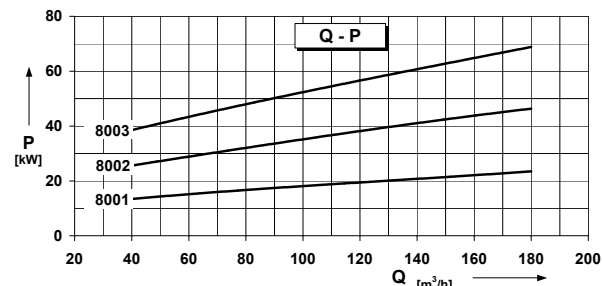
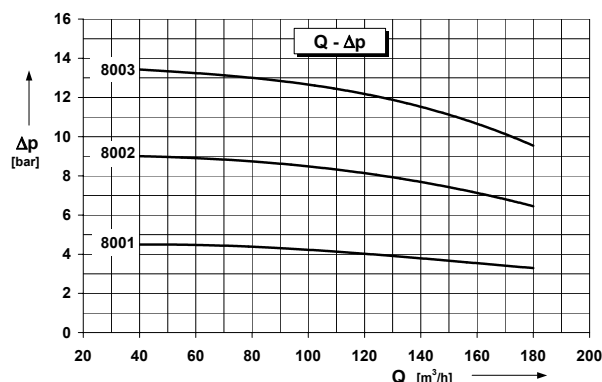

speed = 1450 rpm

sp. gr. = 0,56 kg/dm<sup>3</sup>

