



TOE-MI Series
Heat transfer pumps
for heat transfer oils up to 330 °C

With magnetic coupling in close coupled version
Volute casing in inline design
Hydraulic power ratings in acc. with EN 733

Volute casing PN 16
Bearing bracket 360

motralec

4 rue Lavoisier . ZA Lavoisier . 95223 HERBLAY CEDEX
Tel. : 01.39.97.65.10 / Fax. : 01.39.97.68.48
Demande de prix par e-mail : service-commercial@motralec.com
www.motralec.com

TOE-MI

Heat transfer pumps with magnetic coupling in inline design

TOE-MI Series

Heat transfer pumps for heat transfer oils up to 330 °C

With magnetic coupling in close coupled version
Volute casing in inline design
Hydraulic power ratings are in acc. with EN 733
Volute casing PN 16, bearing bracket 360



Usage

Pumps of the TOE-MI series are designed for the transportation and recirculation of organic liquids on mineral oil or synthetic basis in heat transfer plants in acc. with DIN 4754. Special versions for eutectic mixtures upon request.

They are suitable for clean media to be pumped which do not chemically attack the pump materials used.

Main applications

The pumps are mainly used in the following industrial sectors:

- Tempering in the plastics and die cast industry
- Baking ovens, large frying units as well as in the production of edible oil and dry mass for the food and feedstuff industries
- Heating of calenders and melting pots in the leather and rubber industry
- Heating of agitator and mixing tanks for the processing of colours, paints and lacquers
- Heating of tanks on stationary and FPSE platforms as well as in tank vessels
- Heating of press lines in the wood and pulp industry
- Flat glass production
- Solar power stations & ORC processes

Index

Usage	2
Main applications	2
Operating data	3
Denomination	3
Design details	4
Accessories	5
Tests	5
Painting	5
Performance curves 50 Hz	6
Performance curves 60 Hz	7
Pump dimensions	8
Cross-sectional drawings.....	10
Interchangeability of pump parts	11
Dimensional drawings	12
Pump data sheet	13
Substance data of heat transfer media	14

Operating data

- Flow rate up to approx. 100 m³/h
- Total heads up to approx. 50 m
- Max. operating temperatures up to + 330 °C
(Special versions for eutectic mixtures up to + 400 °C upon request.)

Standard conditions at site

- Relative humidity during continuous operation max. 55%
- Ambient temperature up to + 40 °C
- Permissible altitude up to 1000 m above sea level

Deviations from the site conditions specified herein must already be disclosed in the inquiry.

Flow rate

The permissible operating range of centrifugal pumps depends on diverse factors such as

- impeller shape
- speed
- type of liquid
- viscosity
- bearing load
- heat dissipation - particularly with regard to insulated volute casings
- clearance between the net positive suction head of the plant and the pump
- size of magnet coupling

The hydraulic operating range applicable to the TOE-MI series is indicated in the individual performance curves and the pump data sheet.

Pump outlet pressure

The pump outlet pressure at the outlet nozzle depends on

- the pump inlet pressure
- the maximum total head of the selected impeller diameter
- the density of the medium to be pumped

The maximum pump outlet pressure $p_{2max\ op}$ is calculated using the formula:

$$p_{2max\ op} = p_{1max\ op} + \rho \cdot g \cdot H \cdot 10^{-5}$$

With:

$$p_{2max\ op} = \text{maximum pump outlet pressure [bar]}$$

$$p_{1max\ op} = \text{maximum pump inlet pressure [bar]}$$

$$\rho = \text{density of the medium to be pumped [kg/m}^3\text{]}$$

$$g = \text{gravitation constant [m/s}^2\text{]}$$

$$H = \text{maximum total head at zero flow or at the peak of the pump's characteristic curve at the selected impeller diameter [m]}$$

Pumps must be selected and operated in a way which ensures that the maximum pump outlet pressure does by no means exceed the maximum permissible operating pressure of the casing $p_{all\ w\ c}$ at operating temperature.

This also applies to commissioning while the discharge valve is closed (refer to Fig. 1).

Pressure and temperature limitations

The maximum casing operating pressure $p_{all\ w\ c}$ of the volute casing and the casing cover depends on the operating temperature:

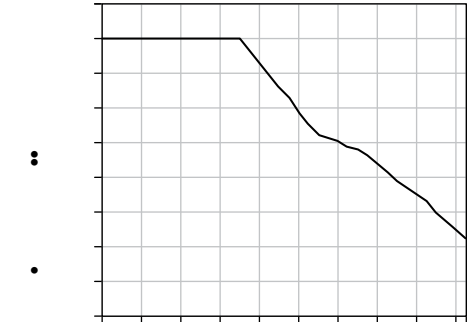

Fig. 1: Maximum permissible casing operating pressure $p_{all\ w\ c}$

Speeds

The operating speed of the pump shaft must not exceed the maximum permissible peripheral speed of the impeller, which corresponds to 48 m/s.

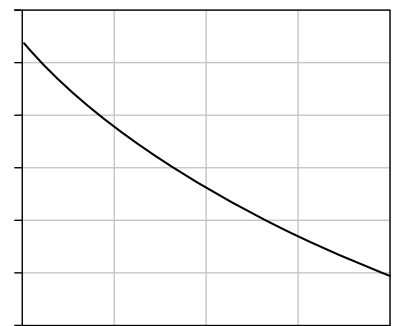

Fig. 2: Maximum permissible shaft speed

Denomination

The denomination of a centrifugal pump of the TOE-MI series with bearing bracket is illustrated in the following example:

TOE - M I 40 - 160 / 150	
	Actual impeller diameter in mm
	Nominal impeller diameter in mm
	Nominal width of outlet nozzle
	Inline design
	Magnetic coupling
	Denomination of series

Design details

Pumps of the TOE-MI series are magnetically-coupled horizontal or vertical, single-stage, single-entry centrifugal pumps with volute casing, radial inlet and radial outlet in process design (disassembly of the plug-in unit while the volute casing remains in the conduit).

The hydraulic power ratings and all dimensions are in accordance with EN 733, 1995 issue.

The tolerances of the mating dimensions are subject to the EN 735 standard.

Allocation of components

Pumps of this series are part of a modular system, whose components can also be used for other pump series.

The complete plug-in unit including the impeller is used in the following series:

TOE-MN - base plate pumps with volute casing featuring axial inlet

TOE-MA - close coupled pumps with volute casing featuring axial inlet

TOE-MI - close coupled pumps with volute casing in inline design

For the parts allocation, refer to page 11.

Materials

•		
••	•	
• •		
•	•	
	- •• €	
, f		
€	• • "	
	- " €	•- ... †

EN-GJS-400-15 = EN-JS1030 = GGG-40
 EN-GJS-400-18LT = EN-JS-1025 = GGG-40.3
 EN-GJL-250 = EN-JL1040 = GG-25

Tab. 1: Materials

Volute casing

The nominal pressure of the volute casing is PN 16.

The outlet and inlet nozzles are fitted with bosses to allow for the subsequent connection of pressure gauges. These ports are only drilled upon request of the customer.

The volute casings are self-venting and may be provided with a plugged drain (G 3/8) when positioned vertically.

Nozzle positions and flanges

• ††	f •
^ ††	
‰	Š • • • • OE • Ž

Tab. 2 : Nozzle positions

Plain bearing bracket

The plain bearing bracket consists of the casing cover, the plain bearing cartridge, the internal rotor and the separating can.

The casing cover accommodates the plain bearing cartridge and the separating can. Depending on the torque to be transferred, the design of the casing cover allows for the use of different magnetic coupling sizes.

The plain bearing cartridge carries the internal rotor and consists of the plain bearing casing, the bearing bushings and the bearing sleeves, which support the radial load and the remaining axial thrust.

The internal rotor consists of the impeller, the shaft and the internal magnetic rotor. Most of the axial forces generated during operation are hydraulically compensated by the impeller.

Via a flow control system, the internal magnetic rotor is continuously cooled with the medium to be pumped to dissipate the heat additionally generated during operation by eddy current, viscosity and bearing friction loss. This way, light ends are prevented from accumulating in the area of the magnetic drive and the plain bearings.

The internal rotor is equipped with a start-up safety device, preventing the separating can from being internally destructed by the rotor in case of a plain bearing failure.

Together with the casing cover and the volute casing, the separating can hermetically seals the part of the pump which is in contact with the media to be pumped.

Plug-in unit

= plain bearing bracket + impeller
 The plain bearing bracket and the volute casing form the pump part which is in direct contact with the medium.

External rotor

The external rotor consists of the shaft and the external magnetic rotor. It transfers the torque exerted by the drive via the magnetic coupling to the internal rotor.

The external rotor is equipped with a start-up safety device, preventing the separating can from being externally destructed by the rotor in case of a ball bearing failure.

Magnetic coupling

The magnetic coupling consists of the following components:

- internal magnetic rotor
- separating can
- external magnetic rotor

Four different coupling sizes with different magnetic lengths are available.

The transferable torques range between 10 and 500 Nm at ambient temperature.

Designation example of a magnetic coupling:

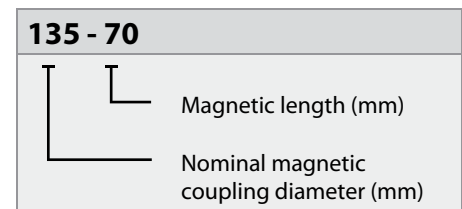

Allocation of the magnetic coupling sizes to be used for the different pump sizes:

Sizes	Nominal impeller diameter in mm		
	160	200	250
	possible magnetic coupling sizes		
•			
	” ’	” ’	
		” ’ ’ ‘	
...		” ’ ’ ‘	

Each magnetic coupling is sized individually by means of an EDP sizing program.

Bracket

In its function as variant carrier of the different pump types TOE-MN, TOE-MA and TOE-MI, the bracket accommodates on one side the inner part and, on the other side, the outer part of the pump. The bracket is provided with radial cooling slots, which support the heat dissipation in the area of the magnetic coupling.

Utility connections

For the exact positions and dimensions of the utility connections, refer to the dimension drawings of the pump on pages 8 and 9.

Accessories

Separating can temperature monitoring

The bracket features threaded connections for the installation of a temperature sensor (PT 100) in case the separating can's surface temperature is to be monitored. The temperature sensor can be supplied with the pump. Non-required threaded connections are closed by a screw plug.

Load monitor

A load monitor with start-up override and release delay can be optionally supplied to monitor the pump for underload and overload or as dry running protection. This load monitor allows for the monitoring of the power factor ($\cos \varphi$) or the active power of the motor and, hence, of the pump aggregate's operating state.

Drives

Surface-cooled three-phase asynchronous motors for low voltages with cage rotor

- design IM B5
- degree of protection IP 54
- insulation class F
- power ratings and dimensions in acc. with DIN 42673 / IEC 72
- make according to our choice

Other motor versions are available upon request.

If the motors are provided by the customer, a sufficient cooling power of the motor fan must be ensured (> 3 m/s flow rate measured at the motor's bearing shield at the pump side).

Tests

If required, test certificates in acc. with DIN 55350-18 can be provided for the individual tests, which, however, has to be indicated in the order.

Material tests in acc. with EN 10204

The exact scope of the tests (which test for which parts) as well as the type of certificate (certificate of compliance with the order, factory certificate, inspection certificate) must be specified in the order.

Non-specific material tests do not have any impact on the delivery time of the pump.

If specific material tests are required, the delivery time of the pump depends on the availability of raw materials and will be checked on a case-to-case basis. Test certificates for specific material tests cannot be provided after the raw materials and/or semi-finished goods have been negotiated.

Gas pressure tests

All pressure bearing parts, e.g.

- volute casing
- casing cover

are subject to a gas pressure test (leakage test).

The gas pressure test is carried out by applying forming gas at 2 bar. The holding time is 15 minutes. By means of this test, the tightness of the parts is proven.

Hydrostatic pressure test

All pressure bearing parts are subject to a pressure test, during which the hydrostatic test pressure (p_{test}) corresponds to 1.3 times the basic design pressure (p_N) at 20° C, following the recommendations of prEN 12162. The holding time is 10 minutes.

If pressure tests are to be carried out in acc. with other criteria, such criteria must be indicated in the inquiry.

By means of this test, the strength of the parts is proven.

Hydraulic tests (performance curves)

If required, hydraulic tests in acc. with ISO 9906, accuracy class II, can be implemented and the performance curves measured for the corresponding impeller diameter documented.

This option has to be indicated accordingly in the order. The purpose of this test is to verify that the duty point of the manufactured pump complies with the contractual duty point.

Painting

The pumps are coated with highly heat-resistant white aluminium paint, colour code RAL 9006.

Performance curves 50 Hz

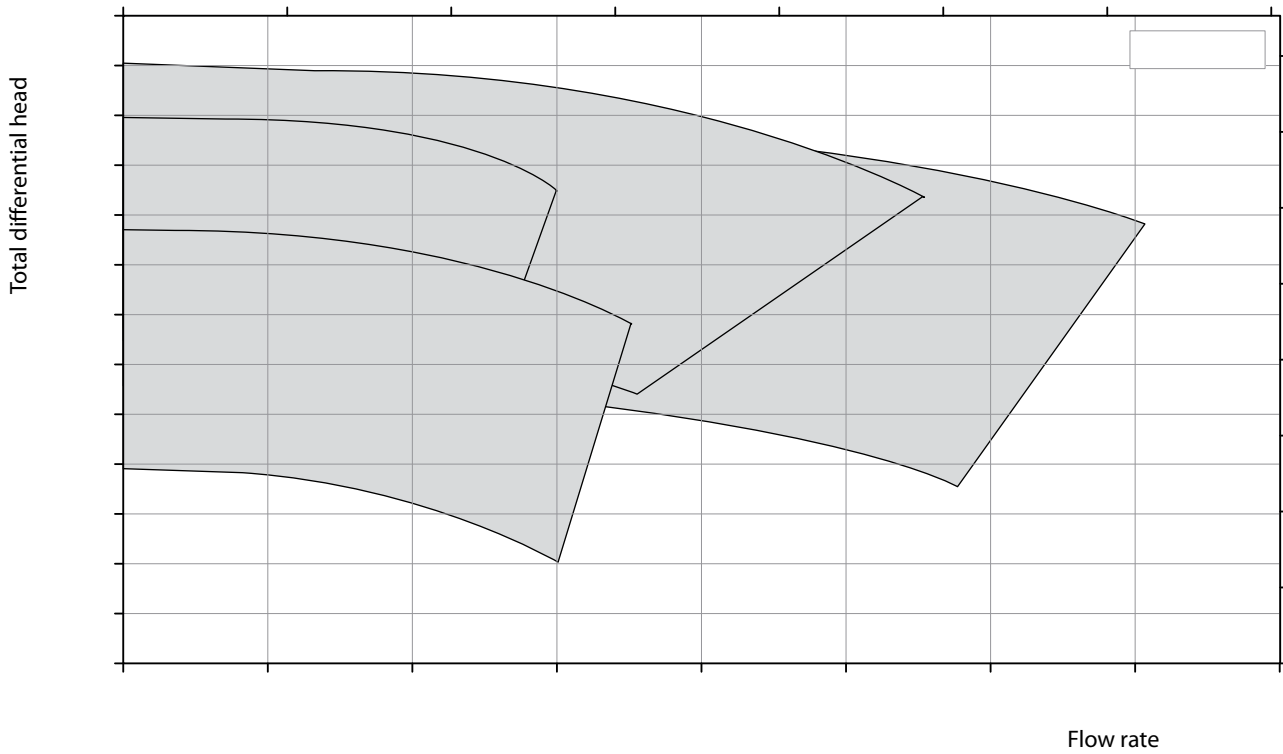
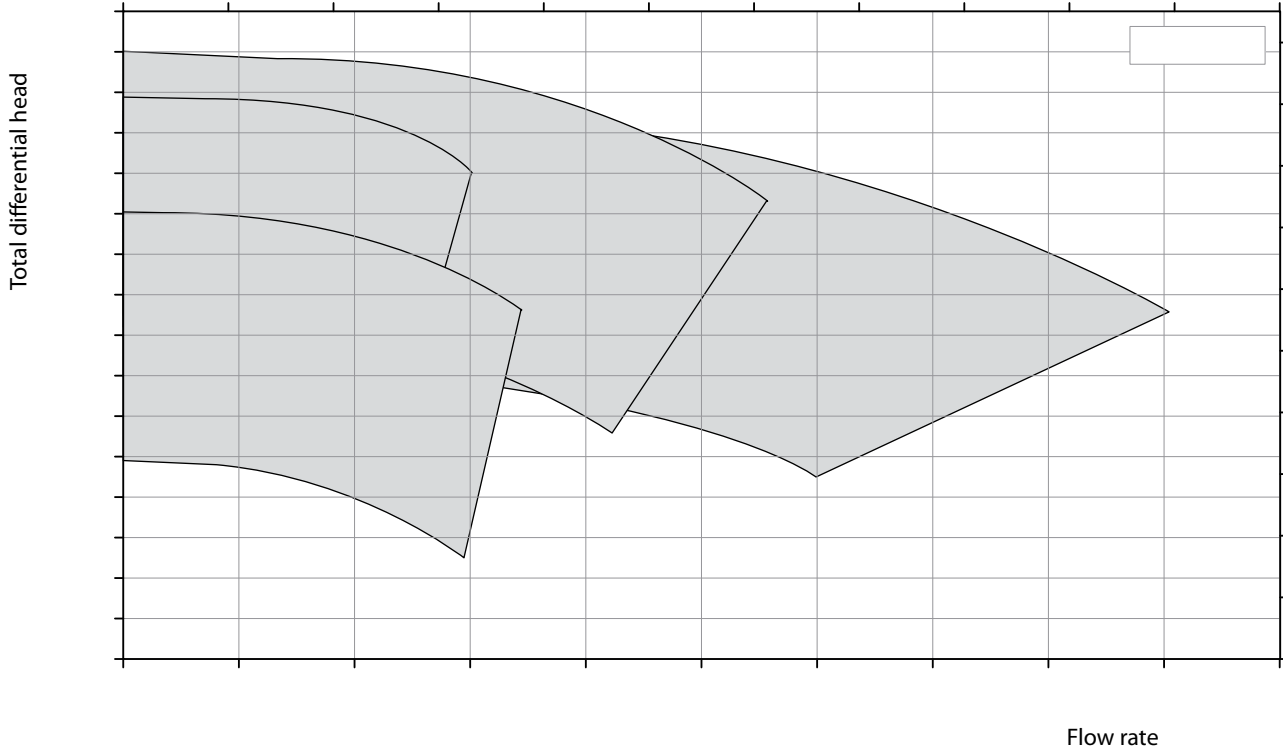

Performance curves 60 Hz

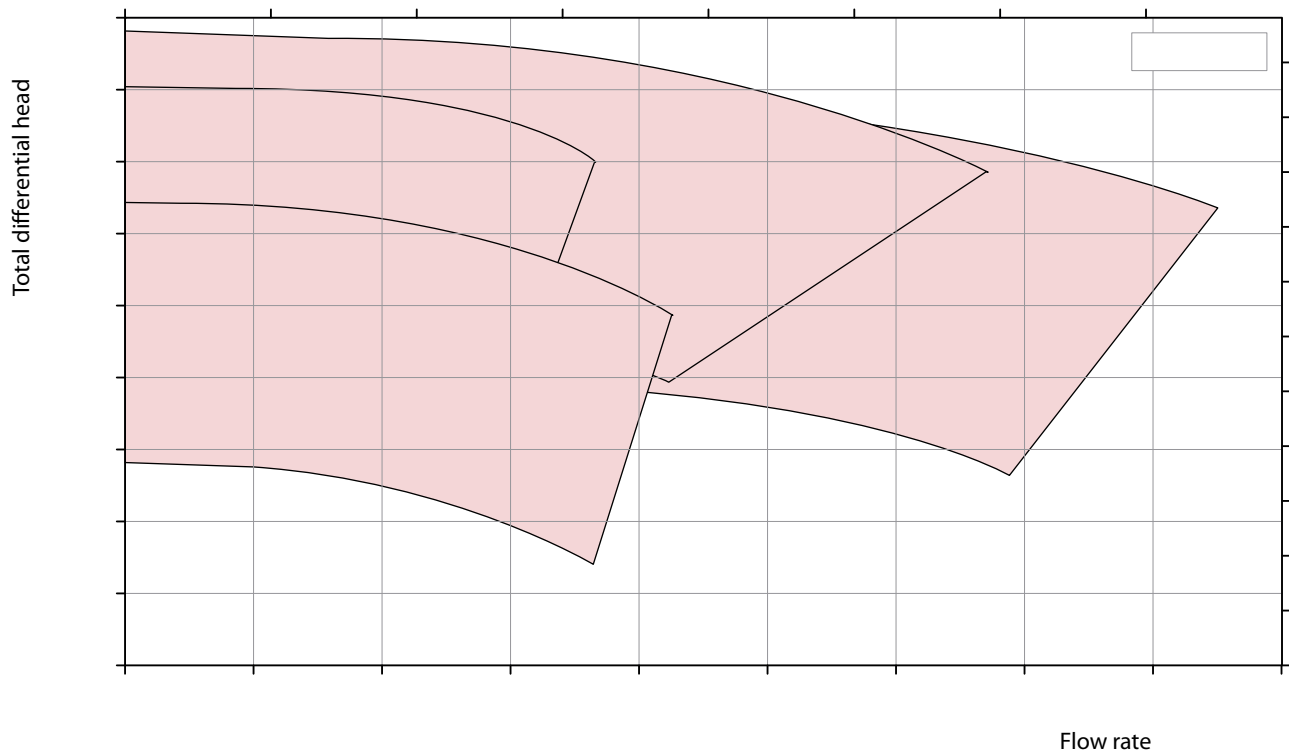
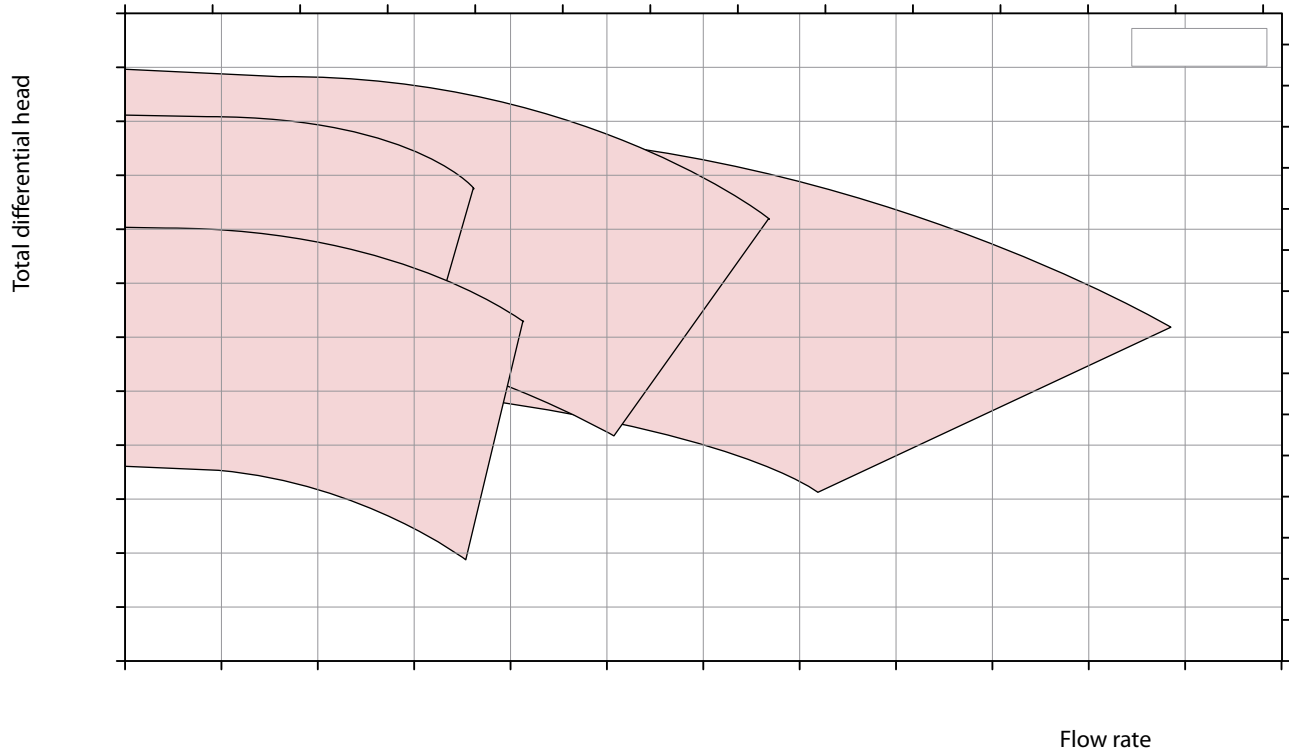

TOE-MI

Heat transfer pumps with magnetic coupling in inline design

Pump dimensions

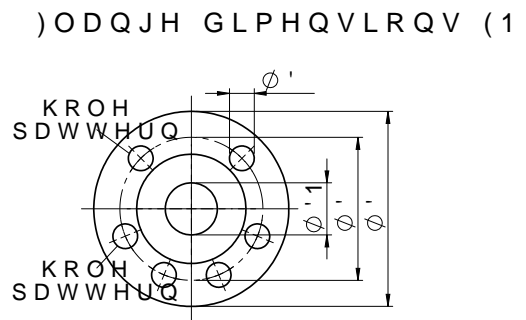
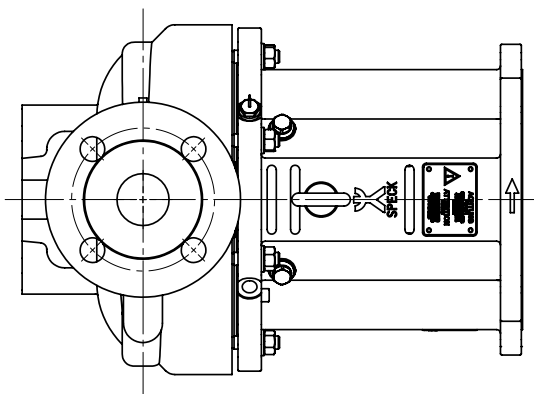
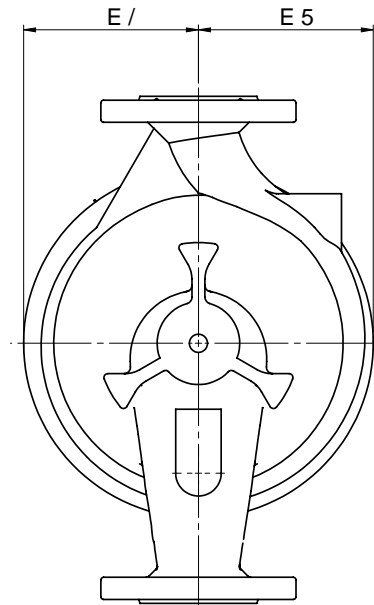
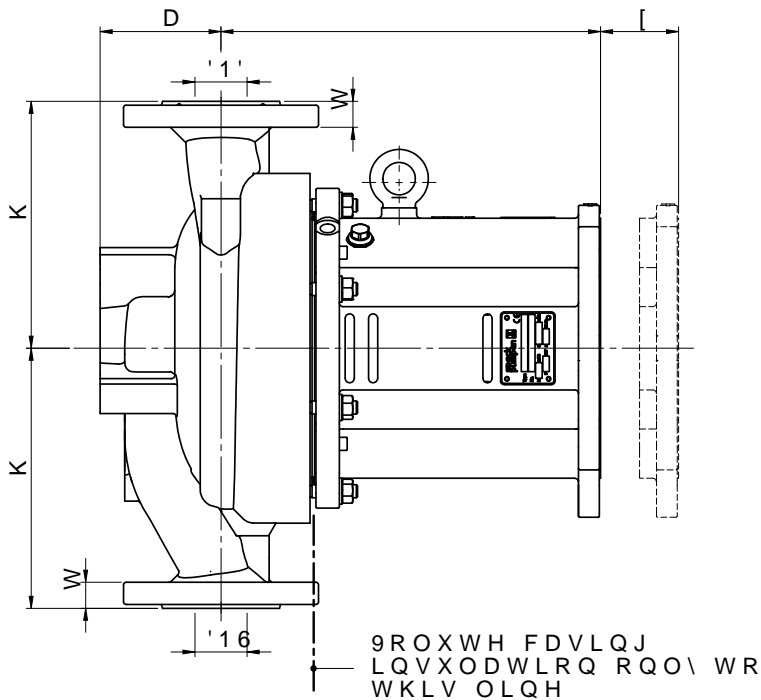

Pump Size	Pump dimensions							Pull-out x
	DNS	DND	a	bL	bR	h1	h2	
40-160			Š ₁	•	Š	
40-200			Š ₁	‘	‘	•	•	
50-200			•	•...	Š	••	•	
65-200	•	‘		•	••	

Utility connections and flange dimensions

Utility connections

P1	^	◁	Ž	'
P2	•	◁	Ž	'
D1				"
T1	•	,	€" ' "	'
T2	•	,	€" "	'

Flange dimensions in acc. with DIN EN 1092-2

øDN	øD2	øD1	t	øD3	Qt. Holes
•				S	
	...	•	•		
...			•		
	•	...	••		
	••		•		

Cross-sectional drawing and part list

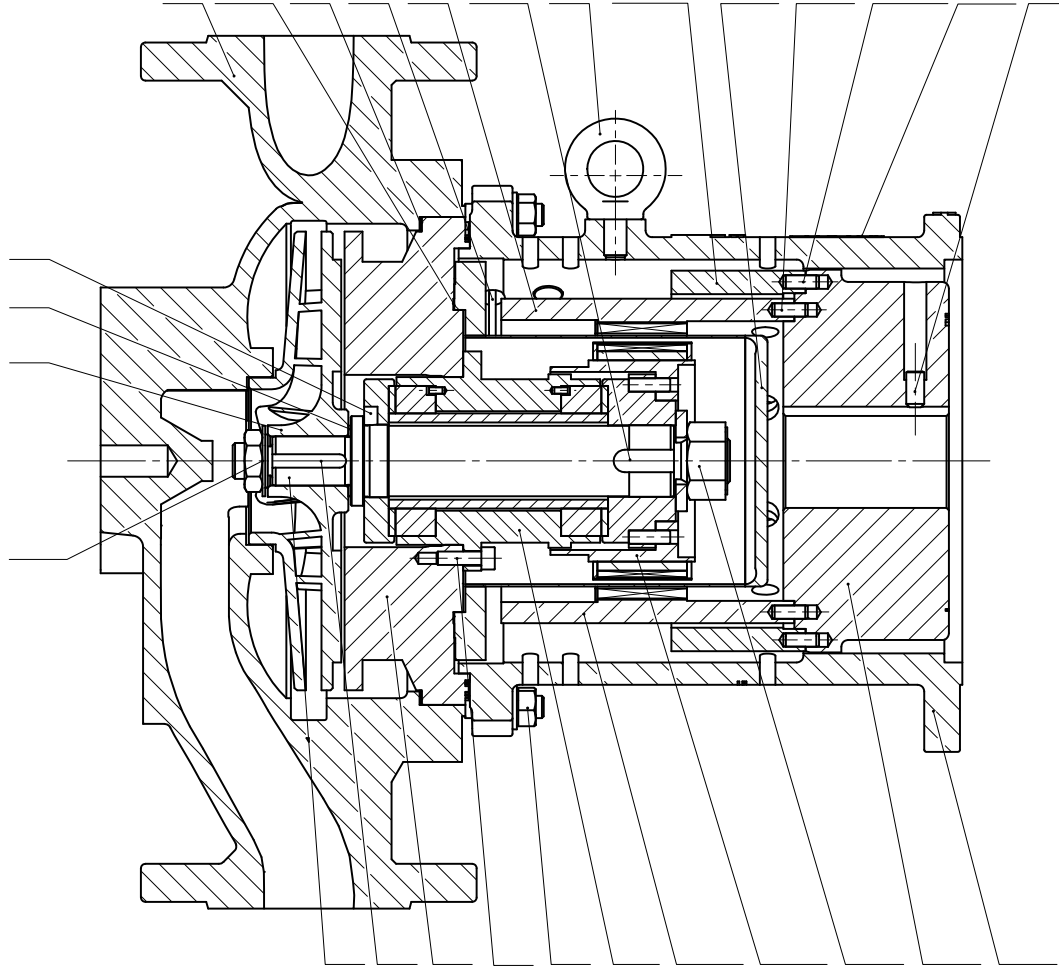

Standard design with nominal impeller diameter 160 and 200 mm

•	
...	•
•	
•'	••
'	• •
'	• •
CE -•	‰ •
-	" •
•••	- •
	-

•	•~
• •-	- •
...	•
... • ... •• CE ... ••,	
...	" •
... Š•	•
...	
'	
"	€ CE •
" •	•

•••	TM
Š"	" f
Š • CE Š ••	
Š' -	~
Š	~
Š Š -'•• CE Š -	• ~
Š • CE Š • - Š • -	Š TM
Š,	• ~
Š Š -	" †
Š Š,	•

* Single components of magnetic coupling (847)
** Execution with MK 75 / 110 only

Interchangeability of parts in between TOE-MN / MA / MI series

Component	Position	Pump type	Pump size										
			32-160	32-200	32-250	40-160	40-200	40-250	50-160	50-200	50-250	65-160	65-200
	•	^ € ' €)		•	'			...	”		Š		•
		^ €•					•			'			
•	...	^ € ' €)		•			•	•		•	•		•
		^ €•					•			•			•
	•	^ € ' €) ' €•											
	••	^ €											
		^ €) ' €•											
••	•'	^ € ' €)		•	'			...	”		Š		•
		^ €•					•			'			
•	'	^ € ' €) ' €•											
• f	'•	^ €											
		^ €) ' €•											
•	“	^ €											
		^ €) ' €•											
• •	'	^ € ' €) ' €•											
• •	'...	^ €											
		^ €) ' €•											
	•	^ €											
		^ €) ' €•											
	”•	^ € ' €)											
		^ €•											
%•	•	^ € ' €) ' €•											
%•	•	^ € ' €)											
		^ €•											
%•	•	^ € ' €) ' €•											
— €“ ” •	•	^ € ' €) ' €•											
— €“ ‘ •	•	^ € ' €) ' €•											
	'	^ € ' €) ' €•											
€	”	^ € ' €) ' €•											
^		^ € ' €) ' €•											

TOE-MI

Heat transfer pumps with magnetic coupling in inline design

Dimensional drawing

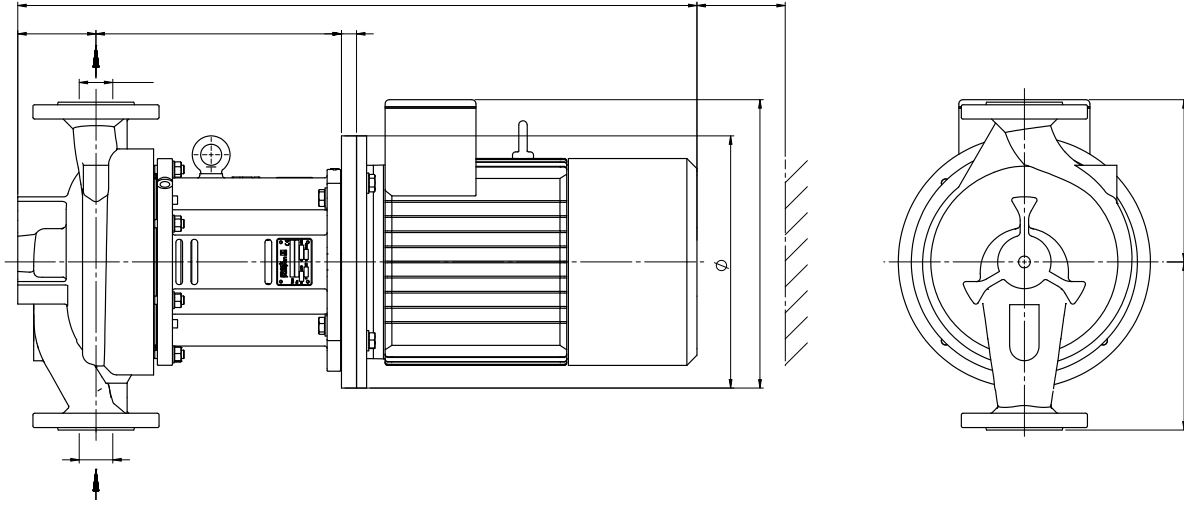

Pump Size	Motor		P ₁ / P ₂	Power kW		Pump dimensions					Pump set dimensions					
	Frame size	De-sign		4-pole	2-pole	DNS	DND	a	h1	h2	øD	HD*	g	o	z*	
			1450 / 1750	2900 / 3500												
40-160	S	•	•	- ' -''	-'' ' -						S	•	€		''	
			•	-	-						•	•	€		''	
	S	•	•	-	••						•	•	€		''	
			•	••	' €	' €			S''	•	S	•	€		'' S	
	S	•	•	-	- ' -''	-'' ' -						€ €			S	•
			•	€	''	''					€ €			S	•	
40-200	S	•	•	- ' -''	-'' ' -						S	•	€		''	
			•	-	-						•	•	€		'' S	
	S	•	•	-	••						•	•	€		''	
			•	••	' €	' €			S'	•	S	•	€		'' S	
	S	•	•	-	- ' -''	-'' ' -						€ €			S	•
			•	€	''	''					€ €			S	•	
50-200	S	•	•	- ' -''	-'' ' -						S	•	€		'' S	
			•	-	-						•	•	€		''	
	S	•	•	-	••						•	•	€		'' S	
			•	••	' €	' €			•	••	•	•	€		'' S	
	S	•	•	-	- ' -''	-'' ' -						€ €			S	•
			•	€	''	''					€ €			S	•	
65-200	S	•	•	- ' -''	-'' ' -						S	•	€		'' S	
			•	-	-						•	•	€		''	
	S	•	•	-	••						•	•	€		''	
			•	••	' €	' €			•	•	••	•	€		'' S	
	S	•	•	-	- ' -''	-'' ' -	•	•	••	€ €			S	•
			•	€	''	''					€ €			S	•	
S	•	•	-	-							€ €			S	•	
		•	€	''	''					€ €			S	•		

*Dimensions can differ depending on the motor supplier.

Pump data sheet

		+HDW 7UDQVIHU 3XPS SWLWRQ	
		7HFKQLFDO 'DWD' 3KRQH	
		3XPS 0RGHO ,WHP	
63(&. 3803(1 6\VVWHPWHFKQLN *PE+			
5HJHQVEXUJHU 5LQJ		5RWK 7HO)D[ZZZ VSHFN SX	
3XPS 0RGHO 4XDQWLW\		3DJH RI SDJHV	
&XVWRPHU /RFDWLRQ		,VV 'SW	
3KRQH)D[3KRQH	
&RQWDFW (0DLO)D[
32 GDWHG		(0DLO	
3URMHFW 3XPS 1R			
,QVWDOODWLRQ (QYLURQPHQW			
%XLOGLQJ 2XWVLGH		P \$PE WHPS 6WDUW XS WHPS UHO	
XQGHU URRI \HV QR		+DJDUGRXV DUHD PLQ PD[PLQ f&	
2SHUDWLQJ &RQWDFWXDO 'DWD			
)OXLG		P K 5HIHUHQFH 6SHHG PLQ	
FRUURVLYH PDWVWVU :JKW)ORZ UDWH PLQ PD[P K GLUHFWLRQ RI URWDWLRQ	
DEUDVLYH PDWVWVU :JKW		3UHVV\ QOHW EDU • +\GU HILFLHQ\	
6ROLG FRQWHQW :JKW		LVFK EDU • K\GU SRZHU FRQV N:	
2SHU 7HPS W\$ R&		7RW 'LII +HDW UDWHG P SRZHU ORVV N:	
'HQVLW\ # W\$ NJ P		SUHVXUH GLI\HUHQWLD EDU 7RWDO DEV SRZHU N:	
.LQ YLVFRVLW\ #W\$ PP V		136+ DYDLODEOH P DEV SRZHU DW FROG WWDUW	
9DSRU SUHVV # W\$ EDU		D UHTXLUHG P 'X\ SRLQW GDWD WR ',1 (1 ,62	
3XPS GHVLQJ			
,PSHOOHU PP		QRP GLDF '1 %HDULQJLPSHOOHU VLGH FRXSOLQ	
1R RI VWDJHV		,QOHW ORFDWLRQ 7\SH	
QRP SUHVXUH 31 EDU		QR]JOH PDFKLQHG WR /XEULFDWLRQ	
PD[DOO &DV SUHVV #DUS		2XWOHW QRP GLDF '1 6KDIW VHDWDFKQLFDO VHDW	
&RROLQJ & +HDWLQJ QR]JOH		ORFDWLRQ 7\SH	
9ROXWH FDV\QJ FR%HDULQJ		EUDFNH PDFKLQHG WR 6L]H	
		6RXQG SUHVXUH OHYHOG% \$4XHQFK \HV QR	
\$FFHVVRULHV			
\$& 3RZHU N:)UDPH		([SURWHFWLRQ 6L]H 6SDFHU PP	
(OHFWULF UHTXHQ\ +) (QFORV)DNH &RXSOLDN	
9RQWDFW 9 &RQWVXFV		'HOLYHUHG E\ 7\SH	
1RP 6SHHG PLQXUHQW		PRXQWHG E\ %DVHSODWH	
0DWHULDQV			
9ROXWH FDV\QJ		EHDULQJ EUDFNH FRQWDLQ\ VKHOO	
&DVLQJ FRYHU		PRWRU ODQWHUQ VOHHYH EHDULQJ	
,PSHOOHU		FDV ZHDU ULQJ FRXSO JXDUG	
6KDIW		LPS ZHDU ULQJ %DVHSODWH	
7HVW DQG ,QVSHFWLRQV			
0DWHULDQV 7HVW .LQZHRW7HVW LILFDW\KHU 7HVW 7HVW :LWQHVWHGHUWLI			
YROXWH FDV\QJ		+ \GURV 3UHVVXUH 7HVW	
&DV &RYHU		*DV 3UHVVXUH 7HVW	
%HDULQJ IUDPH		3HUIRUPDQFH FXUYH	
,PSHOOHU)LQDO FKHFN	
6KDIW			
6KLSSLQJ GDWD			
7RWDO QHW ZHLJKW DSSU		7RWDO JURVV ZHLJKW DSSU	
'RFXPHQDWLRQ			
'LPHQVLRQDO QURVV VHFV GUZJ		3HUIRUPDQFH FXUYH 2SHU 4VWVWDFKWRIDG 2WK	
		/DQJXDJH	
5HPDUNV			
PLQ LQIRUPDWLRQ UHTXLUHG IRU TXRWDWLRQ			
VHHQ IURP GULYHU WR SXPS FDOFXO WR (8523803			
DFF WR (1 YROXWH FDV\QJ FDV\QJ FRYHU			
ZLWKRXW 136+ 7HVW VFRSH RI VXSSO\ VHH SULFH VKHHW			
5HYLVLRQ ,VXHG		'DWH	

Substance data of heat transfer media

•	Water		Marlotherm® SH		Syltherm® XLT		Galden® HT 200	
	- †	“ • ž †	- †	“ • ž †	- †	“ • ž †	- †	“ • ž †
Ÿi ç	Ÿ•'•£ç	Ÿ•••' ç	Ÿ•'•£ç	Ÿ•••' ç	Ÿ•'•£ç	Ÿ•••' ç	Ÿ•'•£ç	Ÿ•••' ç
	¥	¥	¥	¥	¥	¥	Š'	œ
		œ„ Š		'•œ	...•	•œ		œ•
	ŠŠ•	œ...'	'	...œ	•„	œ'	„	œ
	Š	œ•Š	Š„	'œ	„...Š	œ„'	...•	œ ...
	Š„	œ•	Š	œ...'	„	œ	•	œ
...			Š	œ	„•	œ	Š	œ'
			Š'	œ•	...„	œ'		œ'...
•			Š	œŠ•	...•	œ		
••			Š	œ„„	...•	œ„		
•			„	œ...'	Š	œ'		
•...			'	œ„	...'	œ'		
•				œ				
'				œ				
'•			'	œ				
'				œ'...				

Conversion

Reference between height and pressure at different gravities

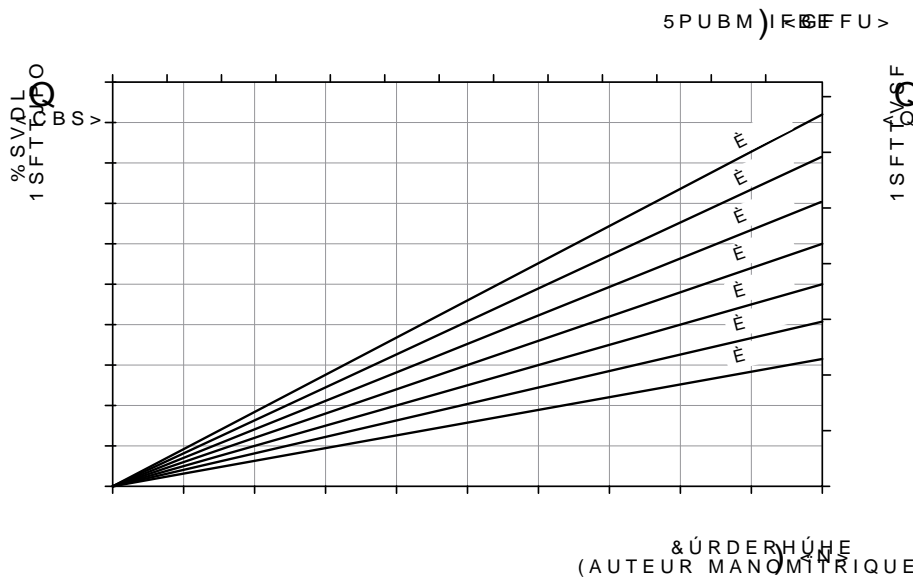

More information?

Then visit our website, where further catalogues can be downloaded.

Speck Pumpen
Production Program

Peripheral Impeller Pumps

- Small Centrifugal Pumps
- Heat Transfer Pumps
- Submersible Pumps

Radial Impeller Pumps

- Small Centrifugal Pumps
- Heat Transfer Pumps with mechanical seal
- Heat Transfer Pumps with magnetic coupling
- Boiler Feed Pumps

Side Channel Pumps

- Pumps - Standard EN 734
- With NPSH-Stage
- Small Pumps

Displacement Pumps

- Roller Vane Pumps
- Gear Pumps
- Oscillating Piston Pump

Liquid Ring Vacuum Pumps

- Close Coupled Version
- Base Plate Version



motralec

4 rue Lavoisier . ZA Lavoisier . 95223 HERBLAY CEDEX

Tel. : 01.39.97.65.10 / Fax. : 01.39.97.68.48

Demande de prix par e-mail : service-commercial@motralec.com

www.motralec.com