



12"

**SAER®**  
**ELETTROPOMPE**
**ELETTROPOMPE SOMMERSE 12" SEMIASSIALI**  
**12" SEMI-AXIAL SUBMERSIBLE ELECTRIC PUMPS**  
**ELECTROBOMBAS SUMERGIDAS SEMIAJIALES 12"**
**6S-302**

**ITALIANO**
**IMPIEGHI**

Idonea per il sollevamento, la pressurizzazione e distribuzione in impianti civili ed industriali, alimentazione di autoclavi e cisterne, impianti di lavaggio, sistemi di irrigazione, con prelievo da pozzi con diametro minimo 310 mm, vasche o bacini naturali.

**CARATTERISTICHE COSTRUTTIVE**

6S-302: gruppo elettropompa completo con motore a bagno d'acqua 8" serie MS201 (fino a 92 kW) o con motore a bagno d'acqua 10" serie MS251 (a partire da 110 kW, fino a 185 kW) o 12" serie MS300 (a partire da 220 kW, fino a 300 kW).

6SP-302: idraulica accoppiabile a motori sommersi 8" con attacco secondo NEMA 18.414-18.424 o motori sommersi 10" o 12" (per l'accoppiamento, fare riferimento alla documentazione specifica per motori sommersi).

Giranti semiasiali.

Bocca di mandata completa di valvola di ritegno.

Controspinta: pompa dotata di anello di controspinta in resina anti-usura.

Bussola di guida in gomma anti-usura con camicia metallica.

Diffusore completo di anello di usura in gomma antiusura.

Componenti realizzati con materiali particolari che assicurano una forte resistenza all'usura.

**MATERIALI - VERSIONI STANDARD**

Giranti: ghisa EN-GJL-250.

Diffusori: ghisa EN-GJL-250.

Albero in acciaio inossidabile AISI431, con bussola conica (albero a profilo scanalato per serie 6XS-6XVS).

Bocca di mandata: ghisa EN-GJS-500/7

Supporto di aspirazione: ghisa EN-GJS-500/7

Dimensioni e tipologia bocche di mandata: bocca di mandata flangiata.

**DATI CARATTERISTICI**

Fluido: chimicamente e meccanicamente non aggressivo, privo di corpi solidi o particelle abrasive.

Passaggio corpi solidi: max 3 mm, granulometria max 50 g/m<sup>3</sup>

Temperatura del liquido pompato: min 0°C max 30°C (oltre, chiedere informazioni).

Pressione massima di esercizio: 39 bar.

Profondità massima di immersione: 300 m

Senso di rotazione: orario, osservando dalla bocca di mandata.

Prestazioni a 3600 1/min

6S-302 A Qmax: 575 m<sup>3</sup>/h / Hmax: 365 m

6S-302 B Qmax: 600 m<sup>3</sup>/h / Hmax: 330 m

**TOLLERANZE PRESTAZIONI**

Pompe: UNI EN ISO 9906 Appendice A, a richiesta Livello 1.

Motore: norme IEC 60034-1.

**INSTALLAZIONE**

Verticale / orizzontale in funzione della potenza.

**VERSIONI SPECIALI**

Serie 6XS e 6XVS interamente in acciaio inossidabile.

Serie 6SB in bronzo marino (fino a max 25 bar)

Tensioni diverse

**ACCESSORI A RICHIESTA**

Quadro elettrico

Giunzione per cavo di alimentazione

**ENGLISH**
**APPLICATION**

Suitable for lifting, pressurising and distribution in civil and industrial installations, autoclave and cistern inlets, washing plants, irrigation systems. Draws from wells of min. diameter of 310 mm, tanks or natural basins.

**CONSTRUCTION FEATURES**

6S-302: complete unit of pump with 8" water filled electric motor

MS201 series (up to 92 kW) or 10" water filled electric motor

MS251 series (starting from 110 kW, up to 185 kW) or 12"

MS300 series (starting from 220 kW, up to 300 kW).

SP-302: hydraulic part to be connected with 8" submersible motors with coupling following NEMA 18.414-18.424 or 10"-12" submersible motors (For coupling, please refer to the specific documentation for the submersible motors).

Semiaxial impellers.

Outlet complete with non return valve.

Pump equipped with counter trust ring in anti-wear resin. Diffuser

complete with wear ring in anti-wear rubber.

Driving bushings in anti-wear rubber with metallic shell.

Components realized with particular materials which assure an high wear resistance.

**MATERIALS - STANDARD VERSION**

Impellers: cast iron EN-GJL-250.

Diffusers: cast iron EN-GJL-250.

Shaft in AISI431 stainless steel with conic bushing (XS and XVS series: shaft with grooved profile).

Outlet: cast iron EN-GJS-500/7

Suction support: cast iron EN-GJS-500/7

Dimensions and type of outlet: Flanged outlet.

**OPERATION DATA**

Fluid: chemically and mechanically non-aggressive, without any solid substance or abrasive parts.

Passing of solids: max 3 mm, maximum solid substance content 50 g/m<sup>3</sup>.

Temperature of the pumped liquid: max 30°C (for higher temperature, please, verify).

Maximum working pressure: 39 bar.

Maximum immersion depth: 300 m under liquid level.

Direction of rotation: clockwise, looking by the outlet.

Performance at 3600 rpm

6S-302 A Qmax: 575 m<sup>3</sup>/h / Hmax: 365 m

6S-302 B Qmax: 600 m<sup>3</sup>/h / Hmax: 330 m

**PERFORMANCE TOLLERANCES**

Pumps: UNI EN ISO 9906 Appendix A, Level 1 on request. Motor: norms IEC 60034-1.

**INSTALLATION**

Vertical / horizontal as a function of power.

**SPECIAL VERSIONS**

6XS and 6XVS Series entirely made of stainless steel 6SB series

made of marine bronze (up to max 25 bar)

Different tensions

**ACCESSORIES ON REQUEST**

Control panel

Cable Joint

**ESPAÑOL**
**APLICACIONES**

Adecuada para la elevación, pressurización y distribución en instalaciones de tipo civil e industrial, distribución a autoclaves y cisternas, sistemas de lavado, sistemas de riego, con trasiego de pozos con diametro min 310 mm, tanques y cuencas.

**CARACTERISTICAS DE CONSTRUCCION**

6S-302: grupo electrobomba completo con motor en bano de agua 8" serie MS201 (asta 92 kW) o 10" serie MS251 (a partir de 110 kW, asta 185 kW) o 12" serie MS300 (a partir de 220 kW asta 300 kW).

SP-302: parte hidraulica para ensamblaje con motores sumergidos 8" con ataque segun NEMA MG1-18.414-18.424 o con motores sumergidos 10"-12" (para el acoplamiento, hacer referencia a la documentación específica para motores sumergidos).

Impulsores semiaxiales.

Boca de descarga completa con valvola de retencion.

Bomba equipada con anillo de contra-empuje en resina antidesgaste.

Difusor completo con anillo de desgaste en goma anti-desgaste.

Casquillos pilotos en goma anti-desgaste con camisa metallica.

Componentes realizados con materiales especiales anti-desgaste.

**MATERIALES - EJECUCIONES ESTANDAR**

Impulsores: fundicion gris EN-GJL-250.

Difusores: fundicion gris EN-GJL-250.

Eje en acero inoxidable AISI431 con casquillo conico (6XS y 6XVS: eje con perfil en ranura).

Boca de descarga y soporte de aspiracion: fundicion gris EN-GJS-500/7

Dimensiones y tipo bocas de descarga: Boca de salida.

**DATOS DE FUNCIONAMIENTO**

Fluido: quimicamente y mecanicamente no agresivo, sin cuerpos solidos o particulas abrasivas.

Pasaje cuerpos solidos: max 3 mm, contenido máximo de particulas sólidas 50 g/m<sup>3</sup>.

Temperatura del liquido bombeado: min 0°C max 30°C (para valores superiores consultar verificación).

Presion de funcionamiento maxima: 39 bar.

Profundidad de sumersion maxima: 300 m debajo del nivel del liquido.

Sentido de rotacion: orario, observando desde la boca de descarga.

Prestaciones en 3600 1/min

6S-302 A Qmax: 575 m<sup>3</sup>/h / Hmax: 365 m

6S-302 B Qmax: 600 m<sup>3</sup>/h / Hmax: 330 m

**TOLERANCIAS PRESTACIONES**

Bombas: UNI EN ISO 9906 Parrafo A, Nivel 1 bajo demanda.

Motor: normas IEC 60034-1.

**INSTALACION**

Vertical / horizontal segun potencia.

**EJECUCIONES ESPECIALES**

Serie 6XS y 6XVS completamente en acero inox

Serie 6SB en bronce marino (hasta max 25 bar)

Varios tensiones.

**ACCESORIOS BAJO DEMANDA**

Quadro electrico

Empalme por cable



# SAER®

## ELETTROPOMPE

# 12"

# 6S-302

### COMPONENTI PRINCIPALI

#### MAIN COMPONENTS

#### COMPONENTES PRINCIPALES

COMPONENTE COMPONENT • COMPONENTE	VERSIONE VERSION • VERSIÓN			
	6S-302	6SB-302	6XS-302	6XVS-302
Albero e giunto Shaft and coupling Eje y manguito	Acciaio inox Stainless steel Acero inox AISI431 (1.4057)	Acciaio inox Stainless steel Acero inox DUPLEX (1.4362)		
Girante Impeller Impulsor	Ghisa Cast iron Fundicion gris EN-GJL-250	Bronzo Bronze Bronce G-CuSn10	Acciaio inox Stainless steel Acero inox AISI316 (1.4408)	
Diffusore Diffuser Difusor	Ghisa Cast iron Fundicion gris EN-GJL-250	Bronzo Bronze Bronce G-CuSn10	Acciaio inox Stainless steel Acero inox AISI316 (1.4408)	
Supporto aspirazione Suction support Soporte de aspiración	Ghisa Cast iron Fundicion gris EN-GJS-500/7	Bronzo Bronze Bronce G-CuSn10	Acciaio inox Stainless steel Acero inox AISI316 (1.4408)	
Bocca di mandata Outlet Orificio de impulsión	Ghisa Cast iron Fundicion gris EN-GJS-500/7	Bronzo Bronze Bronce G-CuSn10	Acciaio inox Stainless steel Acero inox AISI316 (1.4408)	
Copricavo Cable cover Cubrecable	Acciaio inox Stainless steel Acero inox AISI304 (1.4301)	Acciaio inox Stainless steel Acero inox AISI316 (1.4401)		
Parti in gomma Rubber components Partes en goma	Gomma Rubber Goma EPDM			Gomma Rubber Goma Viton
Valvola Valve Valvula	Ghisa Cast iron Fundicion gris EN-GJS-500/7	Acciaio inox Stainless steel Acero inox AISI316 (1.4401)		
Motore Motor Motor	MS201 / MS251 / MS300	MSB201 / MSB251 / MSB300	MSX201 / MSX251 / MSX300	

Elenco completo dei componenti a pag. 170-173 • Complete list of the components on page 170-173 • Lista completa de los componentes a la página 170-173

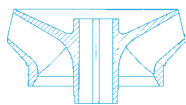

12"

**SAER®**  
**ELETTROPOMPE**
**6S-302**  
**A-B**

**TABELLA DELLE CARATTERISTICHE IDRAULICHE**  
**TABLE OF THE HYDRAULIC FEATURES**  
**TABLA DE LAS CARACTERISTICAS HIDRAULICAS**
**3600 l/min**

Tipo Type	Motore Motor		S.F.	I <sub>sf</sub> (A) 3~		Q	U.S.g.p.m.												
	kW	HP		380V	460V		0												
							2642												
							0	881	1101	1321	1541	1761	1981	2202	2422	2532	2642		
							m <sup>3</sup> /h	0	200	250	300	350	400	450	500	550	575	600	
							l/min	0	3333	4167	5000	5833	6667	7500	8333	9167	9583	10000	
<b>6S-302 A/1B *</b>	67	90	1,15	160	132	H (m)	73	54	52	49	46	42	38	32,5	25				
<b>6S-302 A/1A *</b>	83	113	1,15	194	160		70	63	61	59	56	53	49	44	37	32			
<b>6S-302 A/2B *</b>	132	180	1,15	296	245		146	108	104	98	92	84	76	65	50				
<b>6S-302 A/2A **</b>	170	230	1,15	375	310		140	126	122	118	112	106	98	88	74	64			
<b>6S-302 A/3B *</b>	220	300	1,15	500	413		219	162	156	147	138	126	114	98	75				
<b>6S-302 A/3A</b>	260	350	1,15	580	479		210	192	183	177	168	159	147	132	111	96			
<b>6S-302 A/4B</b>	260	350	1,15	580	479		292	216	208	196	184	168	152	130	100				
<b>6S-302 A/4A</b>	300	400	1,15	655	541		280	252	244	236	224	212	196	176	148	128			
<b>6S-302 A/5B</b>	300	400	1,15	655	541		365	270	260	245	230	210	190	163	125				
Livello minimo di battente alla griglia di aspirazione (m) • Min. hydrostatic head level to the suction grid (m) • Nivel de sumergencia min. de rejilla de aspiración (m)								2	2	2,5	3	4	5,5	5,5	6	6			
<b>6S-302 B/1C *</b>	60	80	1,15	139	115	H (m)	66		53	49	46	43	38	33	27	23	19		
<b>6S-302 B/1A *</b>	83	113	1,15	194	160		75		63	60	57	54	50	46	40	36			
<b>6S-302 B/2C *</b>	132	180	1,15	296	245		132		106	98	92	89	76	66	54	46	38		
<b>6S-302 B/2A **</b>	170	230	1,15	375	310		150		126	120	114	108	100	92	80	72			
<b>6S-302 B/3C **</b>	185	250	1,15	412	340		198		159	147	138	129	114	99	81	69	57		
<b>6S-302 B/3A</b>	260	350	1,15	580	479		225		189	180	171	162	150	138	120	108			
<b>6S-302 B/4C</b>	260	350	1,15	580	479		264		212	196	194	172	152	132	108	92	76		
<b>6S-302 B/5C</b>	300	400	1,15	655	541		330		265	245	230	215	190	165	135	115	95		
Livello minimo di battente alla griglia di aspirazione (m) • Min. hydrostatic head level to the suction grid (m) • Nivel de sumergencia min. de rejilla de aspiración (m)									1	2,5	3	4	5,5	5,5	6	6	6		

\* Funzionamento in orizzontale possibile. Si raccomanda la corretta posa dei supporti onde evitare che l'elettropompa lavori a sbalzo. • Horizontal operation is possible. The motor shall be correctly installed with the relative supports in order to ensure the electric pump works properly • El funcionamiento en posición horizontal es posible. Se aconseja colocar correctamente los soportes oportunos para evitar que la electrobomba funcione en voladizo.

\*\* Funzionamento in orizzontale possibile con motore 12" MS300-250. Si raccomanda la corretta posa dei supporti onde evitare che l'elettropompa lavori a sbalzo. • Horizontal operation is possible with 12" motor MS300-250. The motor shall be correctly installed with the relative supports in order to ensure the electric pump works properly • El funcionamiento en posición horizontal es posible con motor 12" MS300-250. Se aconseja colocar correctamente los soportes oportunos para evitar que la electrobomba funcione en voladizo.

• Potenza nominale motore • Rated power of motor • Potencia nominal del motor



# SAER®

## ELETTROPOMPE

12"

### TABELLA DELLE CARATTERISTICHE IDRAULICHE

#### TABLE OF THE HYDRAULIC FEATURES

#### TABLA DE LAS CARACTERISTICAS HIDRAULICAS

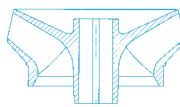

# 6XS-302

## A-B

### 3600 l/min

Tipo Type	Motore Motor		S.F.	I <sub>sf</sub> (A) 3~		Q	U.S.g.p.m.											
	kW	HP		380V			m <sup>3</sup> /h		0	1056	1320	1584	1716	1848	1980	2200	2376	2640
				460V	0		240	300	360	390	420	450	500	540	600			
							0	4000	5000	6000	6500	7000	7500	8333	9000	10000		
<b>6XS-302 A/1B *</b>	60	80	1,15	139	115	H (m)	72	51	48,5	44,5	42	40	37	31,5	25,5			
<b>6XS-302 A/1A *</b>	75	100	1,15	174	143		73	55	54,5	52,5	50	48	46	40	34,5			
<b>6XS-302 A/1 **</b>	92	125	1,15	208	172		102	75	71	65,5	62	60	55,5	49,5	44,5			
<b>6XS-302 A/2B *</b>	132	180	1,15	296	245		136	99	90	84	80,5	76	70,5	60	50			
<b>6XS-302 A/2A *</b>	150	200	1,15	329	272		145	115	106	100	97,5	93,5	89	78,5	69,5			
<b>6XS-302 A/2 ***</b>	185	250	1,15	412	340		167	144	138	134	133	131	126	115	105			
<b>6XS-302 A/3B ***</b>	185	250	1,15	412	340		216	155	142	131	126	118,5	110	93	80,5			
<b>6XS-302 A/4B</b>	260	350	1,15	580	479		280	204	188,5	173,5	167	159	149	126	109			
<b>6XS-302 A/4A</b>	300	400	1,15	655	541		273	236	221	207	202,5	195	185	162,5	145			
<b>6XS-302 A/5B</b>	300	400	1,15	655	541		362	260	240	223	216,5	205,5	192,5	162	141			
Livello minimo di battente alla griglia di aspirazione (m) • Min. hydrostatic head level to the suction grid (m) • Nivel de sumergencia min. de rejilla de aspiración (m)								2	2,5	3	4	4	5,5	5,5	6			
<b>6XS-302 B/1C *</b>	60	80	1,15	139	115	H (m)	66		45	42	39,5	38	35	29,5	25	18		
<b>6XS-302 B/1B *</b>	75	100	1,15	174	143		69		47	45	42,5	41	38	32	27	18		
<b>6XS-302 B/1A **</b>	83	113	1,15	194	160		76		53	51	49	47	45	39	35	25		
<b>6XS-302 B/1 *</b>	110	150	1,15	247	204		82		67	64,5	62	60	58	52	48	40		
<b>6XS-302 B/2C *</b>	110	150	1,15	247	204		129		90	84,5	81,5	77	72	61	50	33		
<b>6XS-302 B/2B *</b>	150	200	1,15	329	272		142		100	94,5	91,5	89	84	73	64	48		
<b>6XS-302 B/2A ***</b>	170	230	1,15	375	310		156		122	114,5	110	108	102	92	80,5	64		
<b>6XS-302 B/3C ***</b>	170	230	1,15	375	310		194		136	126	122	116	108	91,5	75	50		
<b>6XS-302 B/2 **</b>	220	300	1,15	500	413		164		135	128,5	125	121	116	105	96	80		
<b>6XS-302 B/3B **</b>	220	300	1,15	500	413		204		154	144	139	132	125	111	97	73		
<b>6XS-302 B/3A</b>	260	350	1,15	580	479		236		182	171	167	159,5	152	136,5	120,5	96		
<b>6XS-302 B/4B</b>	300	400	1,15	655	541		272		205	191	185	175,5	166	148	130	98		
<b>6XS-302 B/5C</b>	300	400	1,15	655	541		332		240	219,5	210	200	187	160,5	136	102		
Livello minimo di battente alla griglia di aspirazione (m) • Min. hydrostatic head level to the suction grid (m) • Nivel de sumergencia min. de rejilla de aspiración (m)									2,5	3	4	4	5,5	6	6	6		

\* Funzionamento in orizzontale possibile. Si raccomanda la corretta posa dei supporti onde evitare che l'elettropompa lavori a sbalzo. • Horizontal operation is possible. The motor shall be correctly installed with the relative supports in order to ensure the electric pump works properly. • El funcionamiento en posición horizontal es posible. Se aconseja colocar correctamente los soportes oportunos para evitar que la electrobomba funcione en voladizo.

\*\* Funzionamento in orizzontale possibile con motore 10" MSX251-125. Si raccomanda la corretta posa dei supporti onde evitare che l'elettropompa lavori a sbalzo. • Horizontal operation is possible with 10" motor MSX251-125. The motor shall be correctly installed with the relative supports in order to ensure the electric pump works properly. • El funcionamiento en posición horizontal es posible con motor 10" motor MSX251-125. Se aconseja colocar correctamente los soportes oportunos para evitar que la electrobomba funcione en voladizo.

\*\*\* Funzionamento in orizzontale possibile con motore 12" MSX300-250. Si raccomanda la corretta posa dei supporti onde evitare che l'elettropompa lavori a sbalzo. • Horizontal operation is possible with 12" motor MSX300-250. The motor shall be correctly installed with the relative supports in order to ensure the electric pump works properly. • El funcionamiento en posición horizontal es posible con motor 12" MSX300-250. Se aconseja colocar correctamente los soportes oportunos para evitar que la electrobomba funcione en voladizo.

• Potenza nominale motore • Rated power of motor • Potencia nominal del motor



12"

**SAER®**  
**ELETTROPOMPE**

# 6S-302A

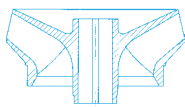
 $\cong$  3600 l/min

**CARATTERISTICHE IDRAULICHE**
**HYDRAULIC FEATURES / CARACTERISTICAS HIDRAULICAS**

Tipo Type	Motore Motor		S.F.	I <sub>sf</sub> (A) 3~		U.S.g.p.m. Q	0	881	1101	1321	1541	1761	1981	2202	2422	2532	
	kW	HP		380V	460V		m <sup>3</sup> /h	0	200	250	300	350	400	450	500	550	575
							l/min	0	3333	4167	5000	5833	6667	7500	8333	9167	9583
6S-302 A/1B *	67	90	1,15	160	132	H (m)	73	54	52	49	46	42	38	32,5	25		
6S-302 A/1A *	83	113	1,15	194	160		70	63	61	59	56	53	49	44	37	32	
6S-302 A/2B *	132	180	1,15	296	245		146	108	104	98	92	84	76	65	50		
6S-302 A/2A **	170	230	1,15	375	310		140	126	122	118	112	106	98	88	74	64	
6S-302 A/3B *	220	300	1,15	500	413		219	162	156	147	138	126	114	98	75		
6S-302 A/3A	260	350	1,15	580	479		210	192	183	177	168	159	147	132	111	96	
6S-302 A/4B	260	350	1,15	580	479		292	216	208	196	184	168	152	130	100		
6S-302 A/4A	300	400	1,15	655	541		280	252	244	236	224	212	196	176	148	128	
6S-302 A/5B	300	400	1,15	655	541		365	270	260	245	230	210	190	163	125		
Livello minimo di battente alla griglia di aspirazione (m) • Min. hydrostatic head level to the suction grid (m) • Nivel de sumergencia min. de rejilla de aspiración (m)								2	2	2,5	3	4	5,5	5,5	6	6	

\* Funzionamento in orizzontale possibile. Si raccomanda la corretta posa dei supporti onde evitare che l'elettropompa lavori a sbalzo. • Horizontal operation is possible. The motor shall be correctly installed with the relative supports in order to ensure the electric pump works properly • El funcionamiento en posición horizontal es posible. Se aconseja colocar correctamente los soportes oportunos para evitar que la electrobomba funcione en voladizo.

\*\* Funzionamento in orizzontale possibile con motore 12" MS300-250. Si raccomanda la corretta posa dei supporti onde evitare che l'elettropompa lavori a sbalzo. • Horizontal operation is possible with 12" motor MS300-250. The motor shall be correctly installed with the relative supports in order to ensure the electric pump works properly • El funcionamiento en posición horizontal es posible con motor 12" MS300-250. Se aconseja colocar correctamente los soportes oportunos para evitar que la electrobomba funcione en voladizo.

• Potenza nominale motore • Rated power of motor • Potencia nominal del motor

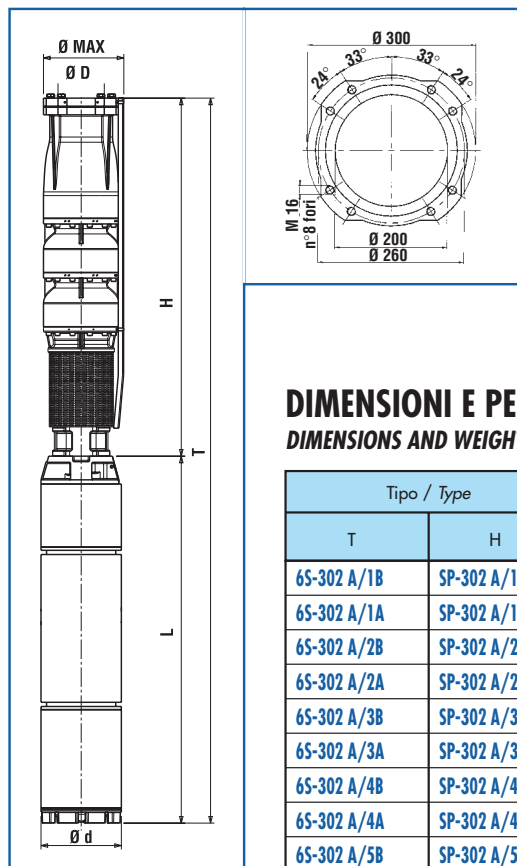
**DIMENSIONI E PESI**
**DIMENSIONS AND WEIGHT / DIMENSIONES Y PESOS**

Tipo / Type		T	H	L	Ø Max	Ø D	Ø d	Motore Motor	NEMA	Peso Weight (Kg)	
T	H									H	T
6S-302 A/1B	SP-302 A/1B	2190	955	1235	301	8"	192	8" MS 201	1.18.424	130	334
6S-302 A/1A	SP-302 A/1A	2370	955	1415	301	8"	192	8" MS 201	1.18.424	130	369
6S-302 A/2B	SP-302 A/2B	2720	1150	1570	301	8"	238	10" MS 251	-	165	563
6S-302 A/2A	SP-302 A/2A	2950	1150	1800	301	8"	238	10" MS 251	-	165	619
6S-302 A/3B	SP-302 A/3B	3105	1345	1760	301	8"	288	12" MS 300	-	200	830
6S-302 A/3A	SP-302 A/3A	3255	1345	1910	301	8"	288	12" MS 300	-	200	897
6S-302 A/4B	SP-302 A/4B	3450	1540	1910	301	8"	288	12" MS 300	-	235	932
6S-302 A/4A	SP-302 A/4A	3600	1540	2060	301	8"	288	12" MS 300	-	235	1000
6S-302 A/5B	SP-302 A/5B	3795	1735	2060	301	8"	288	12" MS 300	-	270	1035



# SAER®

## ELETTROPOMPE

12"

≈ 3600 l/min

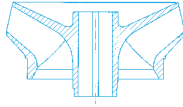

# 6S-302A

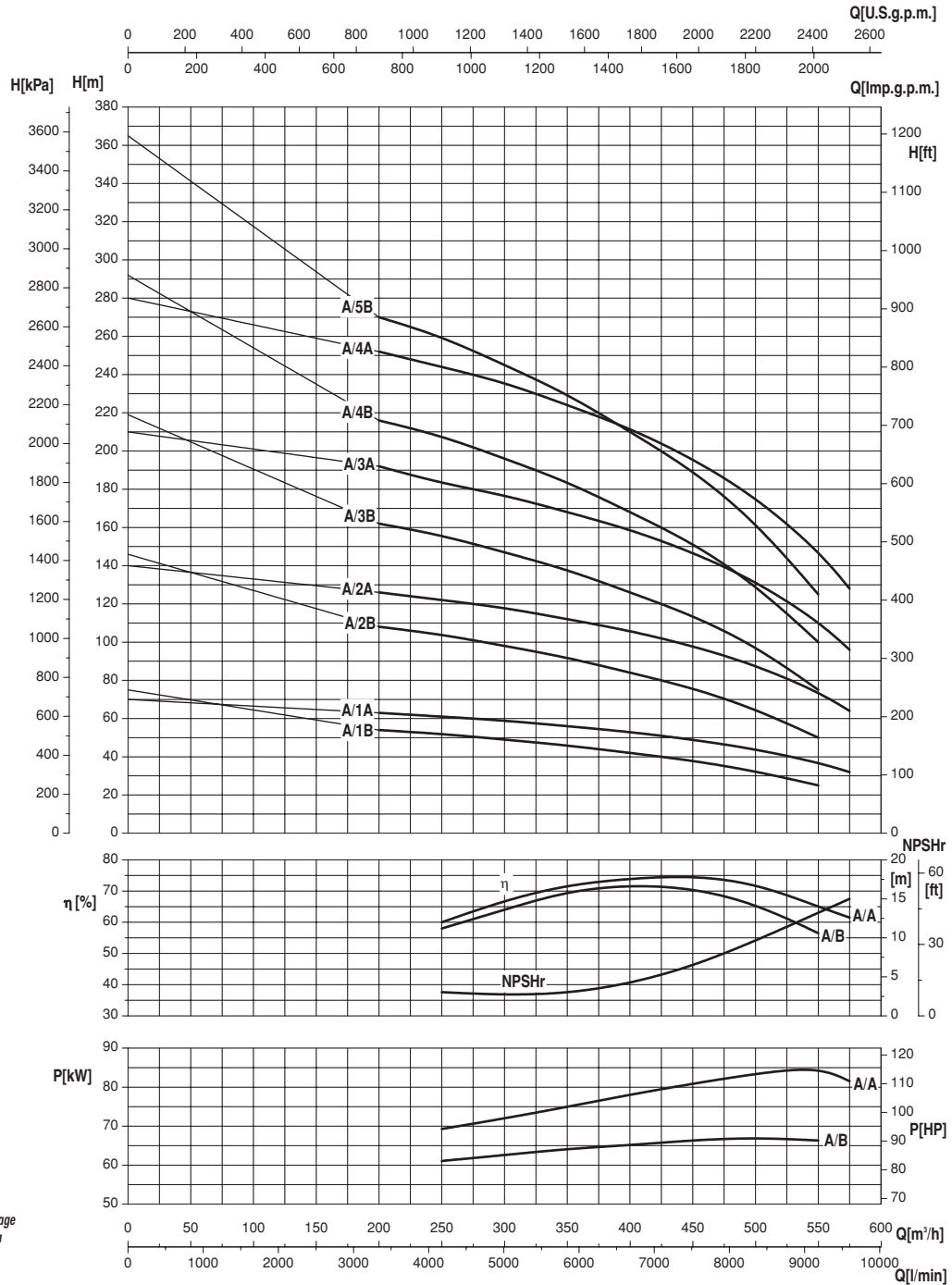

Moltiplicare il rendimento per il coefficiente corrispondente al vostro numero di stadi.

Multiply efficiency by the coefficient corresponding the number of stages.

Multiplícar el rendimiento por el coeficiente correspondiente a su número de etapas.

Numero di stadi Number of stage Número de etapas	1	2	3	>3
Coefficienti Coefficient Coeficiente	0,97	0,98	0,99	1

- Potenza assorbita per stadio
- Absorbed power for each single stage
- Potencia absorbida por cada etapa

Le curve di prestazione sono basate su valori di viscosità cinematica = 1 mm<sup>2</sup>/s e densità pari a 1000 kg/m<sup>3</sup>. Tolleranza e curve secondo UNI EN ISO 9906 - Appendice A • The performance curves are based on the kinematic viscosity values = 1 mm<sup>2</sup>/s and density equal to 1000 kg/m<sup>3</sup>. Tolerance and curves according to UNI EN ISO 9906 - Attachment A • Las curvas de rendimiento se refieren a valores de viscosidad cinemática = 1 mm<sup>2</sup>/s y densidad de 1000 Kg/m<sup>3</sup>. Tolerancia de las curvas de acuerdo con UNI EN ISO 9906 - Parrafo A.

I dati sono riferiti a metallurgia standard. Per versioni 6XS-6XVS-6SB vedere dati specifici. • The data are referred to standard metallurgy. For versions 6XS-6XVS-6SB, please refer to specific data. • Los datos se refieren a metallurgia estandard. Para versiones 6XS-6XVS-6SB hacer referencia a los datos específicos.



12"

**SAER®**  
**ELETTROPOMPE**

# 6S-302B

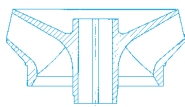
 $\cong$  3600 l/min

## CARATTERISTICHE IDRAULICHE

**HYDRAULIC FEATURES / CARACTERISTICAS HIDRAULICAS**

Tipo Type	Motore Motor		S.F.	I <sub>sf</sub> (A) 3~		U.S.g.p.m. Q	0	1101	1321	1541	1761	1981	2202	2422	2532	2642		
	kW	HP		380V	460V		m <sup>3</sup> /h	l/min	0	250	300	350	400	450	500	550	575	600
							H (m)											
6S-302 B/1C *	60	80	1,15	139	115	H (m)	66	53	49	46	43	38	33	27	23	19		
6S-302 B/1A *	83	113	1,15	194	160		75	63	60	57	54	50	46	40	36			
6S-302 B/2C *	132	180	1,15	296	245		132	106	98	92	89	76	66	54	46	38		
6S-302 B/2A **	170	230	1,15	375	310		150	126	120	114	108	100	92	80	72			
6S-302 B/3C **	185	250	1,15	412	340		198	159	147	138	129	114	99	81	69	57		
6S-302 B/3A	260	350	1,15	580	479		225	189	180	171	162	150	138	120	108			
6S-302 B/4C	260	350	1,15	580	479		264	212	196	194	172	152	132	108	92	76		
6S-302 B/5C	300	400	1,15	655	541		330	265	245	230	215	190	165	135	115	95		
Livello minimo di battente alla griglia di aspirazione (m) • Min. hydrostatic head level to the suction grid (m) • Nivel de sumergencia min. de rejilla de aspiración (m)								1	2,5	3	4	5,5	5,5	6	6	6		

\* Funzionamento in orizzontale possibile. Si raccomanda la corretta posa dei supporti onde evitare che l'elettropompa lavori a sbalzo. • Horizontal operation is possible. The motor shall be correctly installed with the relative supports in order to ensure the electric pump works properly • El funcionamiento en posición horizontal es posible. Se aconseja colocar correctamente los soportes oportunos para evitar que la electrobomba funcione en voladizo.

\*\* Funzionamento in orizzontale possibile con motore 12" MS300-250. Si raccomanda la corretta posa dei supporti onde evitare che l'elettropompa lavori a sbalzo. • Horizontal operation is possible with 12" motor MS300-250. The motor shall be correctly installed with the relative supports in order to ensure the electric pump works properly • El funcionamiento en posición horizontal es posible con motor 12" MS300-250. Se aconseja colocar correctamente los soportes oportunos para evitar que la electrobomba funcione en voladizo.

• Potenza nominale motore • Rated power of motor • Potencia nominal del motor

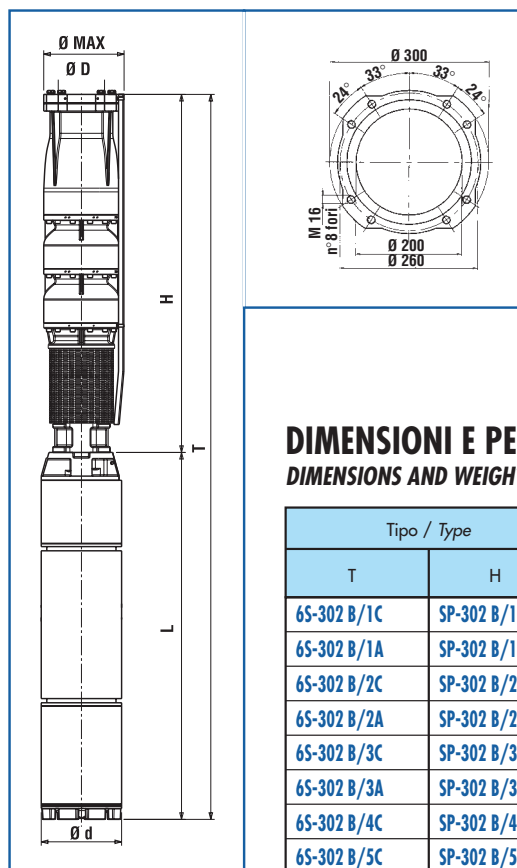

## DIMENSIONI E PESI

**DIMENSIONS AND WEIGHT / DIMENSIONES Y PESOS**

Tipo / Type		T	H	L	Ø Max	Ø D	Ø d	Motore Motor	NEMA	Peso Weight (Kg)	
T	H	(mm)	(mm)	(mm)	(mm)	"G	(mm)			H	T
6S-302 B/1C	SP-302 B/1C	2090	955	1135	301	8"	192	8" MS 201	1.18.424	130	314
6S-302 B/1A	SP-302 B/1A	2370	955	1415	301	8"	192	8" MS 201	1.18.424	130	369
6S-302 B/2C	SP-302 B/2C	2720	1150	1570	301	8"	238	10" MS 251	-	165	563
6S-302 B/2A	SP-302 B/2A	2950	1150	1800	301	8"	238	10" MS 251	-	165	619
6S-302 B/3C	SP-302 B/3C	3255	1345	1910	301	8"	238	10" MS 251	-	200	681
6S-302 B/3A	SP-302 B/3A	3255	1345	1910	301	8"	288	12" MS 300	-	200	897
6S-302 B/4C	SP-302 B/4C	3450	1540	1910	301	8"	288	12" MS 300	-	235	932
6S-302 B/5C	SP-302 B/5C	3795	1735	2060	301	8"	288	12" MS 300	-	270	1035



# SAER®

## ELETTROPOMPE

12"

≈ 3600 l/min

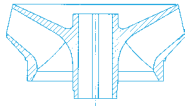

# 6S-302B

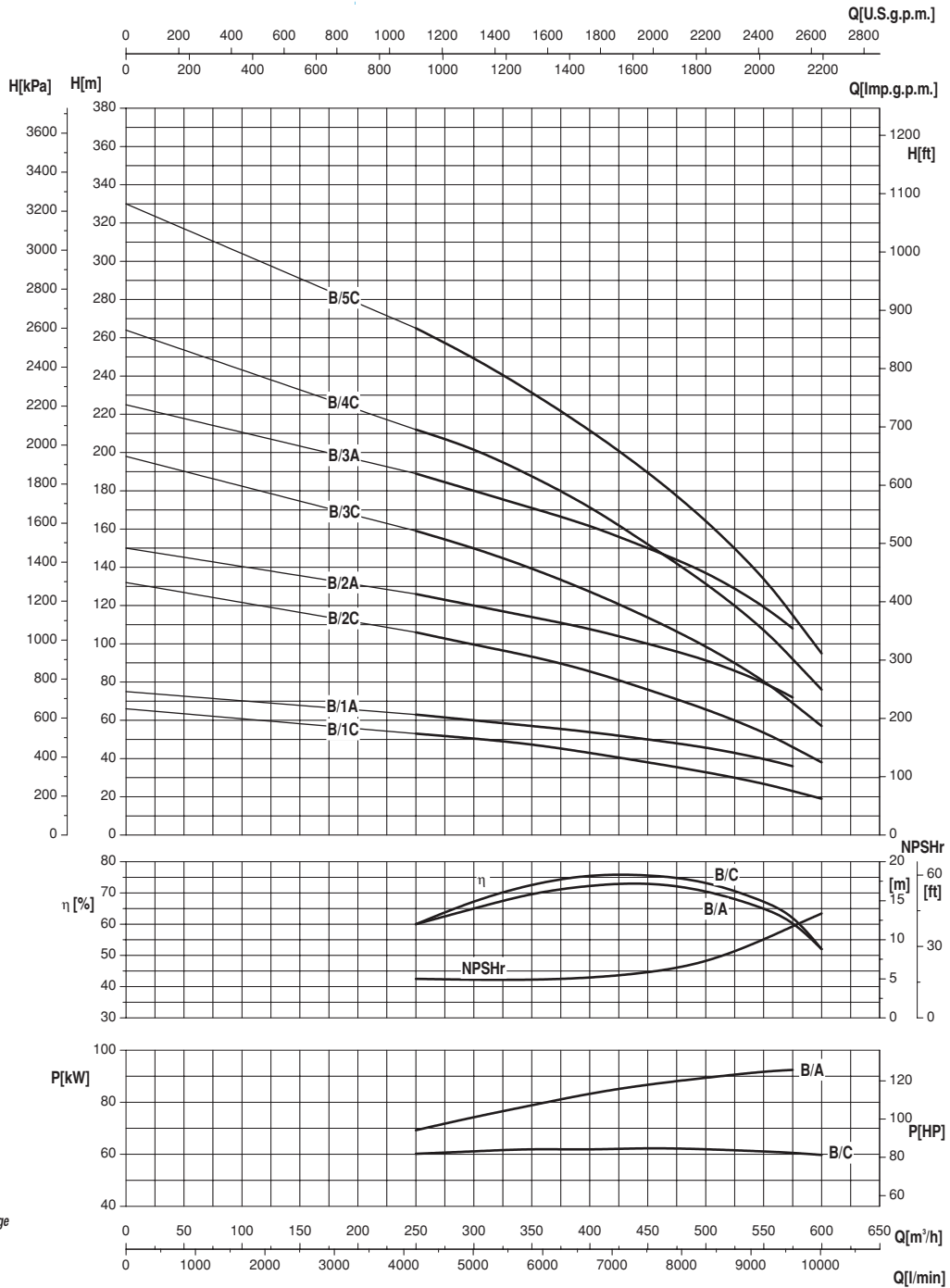

Moltiplicare il rendimento per il coefficiente corrispondente al vostro numero di stadi.

Multiply efficiency by the coefficient corresponding the number of stages.

Multiplicar el rendimiento por el coeficiente correspondiente a Su numero de etapas.

Numero di stadi Number of stage Numero de etapas	1	2	3	>3
Coefficienti Coefficient Coeficiente	0,97	0,98	0,99	1

- Potenza assorbita per stadio
- Absorbed power for each single stage
- Potencia absorbida por cada etapa

Le curve di prestazione sono basate su valori di viscosità cinematica = 1 mm<sup>2</sup>/s e densità pari a 1000 kg/m<sup>3</sup>. Tolleranza e curve secondo UNI EN ISO 9906 - Appendice A • The performance curves are based on the kinematic viscosity values = 1 mm<sup>2</sup>/s and density equal to 1000 kg/m<sup>3</sup>. Tolerance and curves according to UNI EN ISO 9906 - Attachment A • Las curvas de rendimiento se refieren a valores de viscosidad cinemática = 1 mm<sup>2</sup>/s y densidad de 1000 Kg/m<sup>3</sup>. Tolerancia de las curvas de acuerdo con UNI EN ISO 9906 - Parrafo A.

I dati sono riferiti a metallurgia standard. Per versioni 6XS-6XVS-6SB vedere dati specifici. • The data are referred to standard metallurgy. For versions 6XS-6XVS-6SB, please refer to specific data. • Los datos se refieren a metalurgia estandard. Para versiones 6XS-6XVS-6SB ver datos específicos.



12"

**SAER®**  
**ELETTROPOMPE**

# 6XS-302A

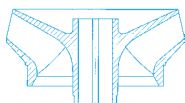
 $\cong$  3600 1/min

**CARATTERISTICHE IDRAULICHE**
**HYDRAULIC FEATURES / CARACTERISTICAS HIDRAULICAS**

Tipo Type	Motore Motor		S.F.	I <sub>sf</sub> (A) 3~		U.S.g.p.m. Q	0	1056	1188	1320	1452	1584	1716	1848	1980	2200	2376
	kW	HP		380V	460V		m <sup>3</sup> /h	240	270	300	330	360	390	420	450	500	540
				l/min													
6XS-302 A/1B *	60	80	1,15	139	115	H (m)	72	51	49,5	48,5	45,5	44,5	42	40	37	31,5	25,5
6XS-302 A/1A *	75	100	1,15	174	143		73	55	54	54,5	53,5	52,5	50	48	46	40	34,5
6XS-302 A/1 **	92	125	1,15	208	172		102	75	71,5	71	68	65,5	62	60	55,5	49,5	44,5
6XS-302 A/2B *	132	180	1,15	296	245		136	99	94	90	87	84	80,5	76	70,5	60	50
6XS-302 A/2A *	150	200	1,15	329	272		145	115	110	106	102	100	97,5	93,5	89	78,5	69,5
6XS-302 A/2 ***	185	250	1,15	412	340		167	144	141	138	136	134	133	131	126	115	105
6XS-302 A/3B ***	185	250	1,15	412	340		216	155	147,5	142	136,5	131	126	118,5	110	93	80,5
6XS-302 A/4B	260	350	1,15	580	479		280	204	197	188,5	181	173,5	167	159	149	126	109
6XS-302 A/4A	300	400	1,15	655	541		273	236	228,5	221	214	207	202,5	195	185	162,5	145
6XS-302 A/5B	300	400	1,15	655	541		362	260	250,5	240	234	223	216,5	205,5	192,5	162	141
Livello minimo di battente alla griglia di aspirazione (m) • Min. hydrostatic head level to the suction grid (m) • Nivel de sumergencia min. de rejilla de aspiración (m)								2	2	2,5	2,5	3	4	4	5,5	5,5	6

\* Funzionamento in orizzontale possibile. Si raccomanda la corretta posa dei supporti onde evitare che l'elettropompa lavori a sbalzo. • Horizontal operation is possible. The motor shall be correctly installed with the relative supports in order to ensure the electric pump works properly. • El funcionamiento en posición horizontal es posible. Se aconseja colocar correctamente los soportes oportunos para evitar que la electrobomba funcione en voladizo.

\*\* Funzionamento in orizzontale possibile con motore 10" MSX251-125. Si raccomanda la corretta posa dei supporti onde evitare che l'elettropompa lavori a sbalzo. • Horizontal operation is possible with 10" motor MSX251-125. The motor shall be correctly installed with the relative supports in order to ensure the electric pump works properly. • El funcionamiento en posición horizontal es posible con motor 10" motor MSX251-125. Se aconseja colocar correctamente los soportes oportunos para evitar que la electrobomba funcione en voladizo.

\*\*\* Funzionamento in orizzontale possibile con motore 12" MSX300-250. Si raccomanda la corretta posa dei supporti onde evitare che l'elettropompa lavori a sbalzo. • Horizontal operation is possible with 12" motor MSX300-250. The motor shall be correctly installed with the relative supports in order to ensure the electric pump works properly. • El funcionamiento en posición horizontal es posible con motor 12" MSX300-250. Se aconseja colocar correctamente los soportes oportunos para evitar que la electrobomba funcione en voladizo.

• Potenza nominale motore • Rated power of motor • Potencia nominal del motor

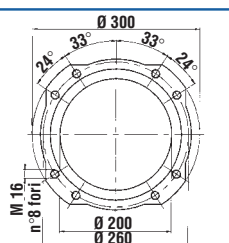
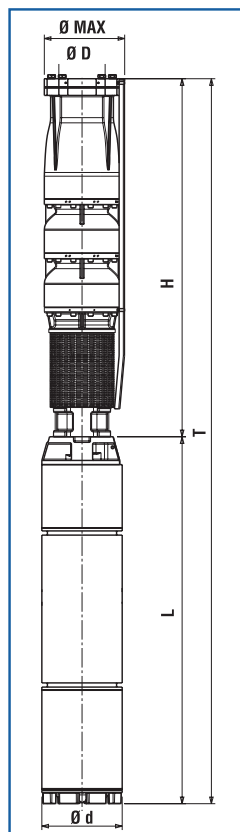
**DIMENSIONI E PESI**
**DIMENSIONS AND WEIGHT / DIMENSIONES Y PESOS**

Tipo / Type		T	H	L	Ø Max	Ø D	Ø d	Motore Motor	NEMA	Peso Weight (Kg)	
T	H									H	T
6XS-302 A/1B	XSP-302 A/1B	2090	955	1135	301	8"	192	8" MSX 201	1.18.424	130	314
6XS-302 A/1A	XSP-302 A/1A	2290	955	1335	301	8"	192	8" MSX 201	1.18.424	130	353
6XS-302 A/1	XSP-302 A/1	2450	955	1495	301	8"	192	8" MSX 201	1.18.424	130	385
6XS-302 A/2B	XSP-302 A/2B	2720	1150	1570	301	8"	238	10" MSX 251	-	165	563
6XS-302 A/2A	XSP-302 A/2A	2810	1150	1660	301	8"	238	10" MSX 251	-	165	585
6XS-302 A/2	XSP-302 A/2	3060	1150	1910	301	8"	238	10" MSX 251	-	165	646
6XS-302 A/3B	XSP-302 A/3B	3255	1345	1910	301	8"	288	12" MSX 300	-	200	681
6XS-302 A/4B	XSP-302 A/4B	3450	1540	1910	301	8"	288	12" MSX 300	-	235	932
6XS-302 A/4A	XSP-302 A/4A	3600	1540	2060	301	8"	288	12" MSX 300	-	235	1000
6XS-302 A/5B	XSP-302 A/5B	3795	1735	2060	301	8"	288	12" MSX 300	-	270	1035



# SAER®

12"

## ELETTROPOMPE

≈ 3600 l/min

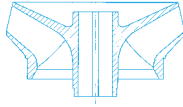

# 6XS-302A

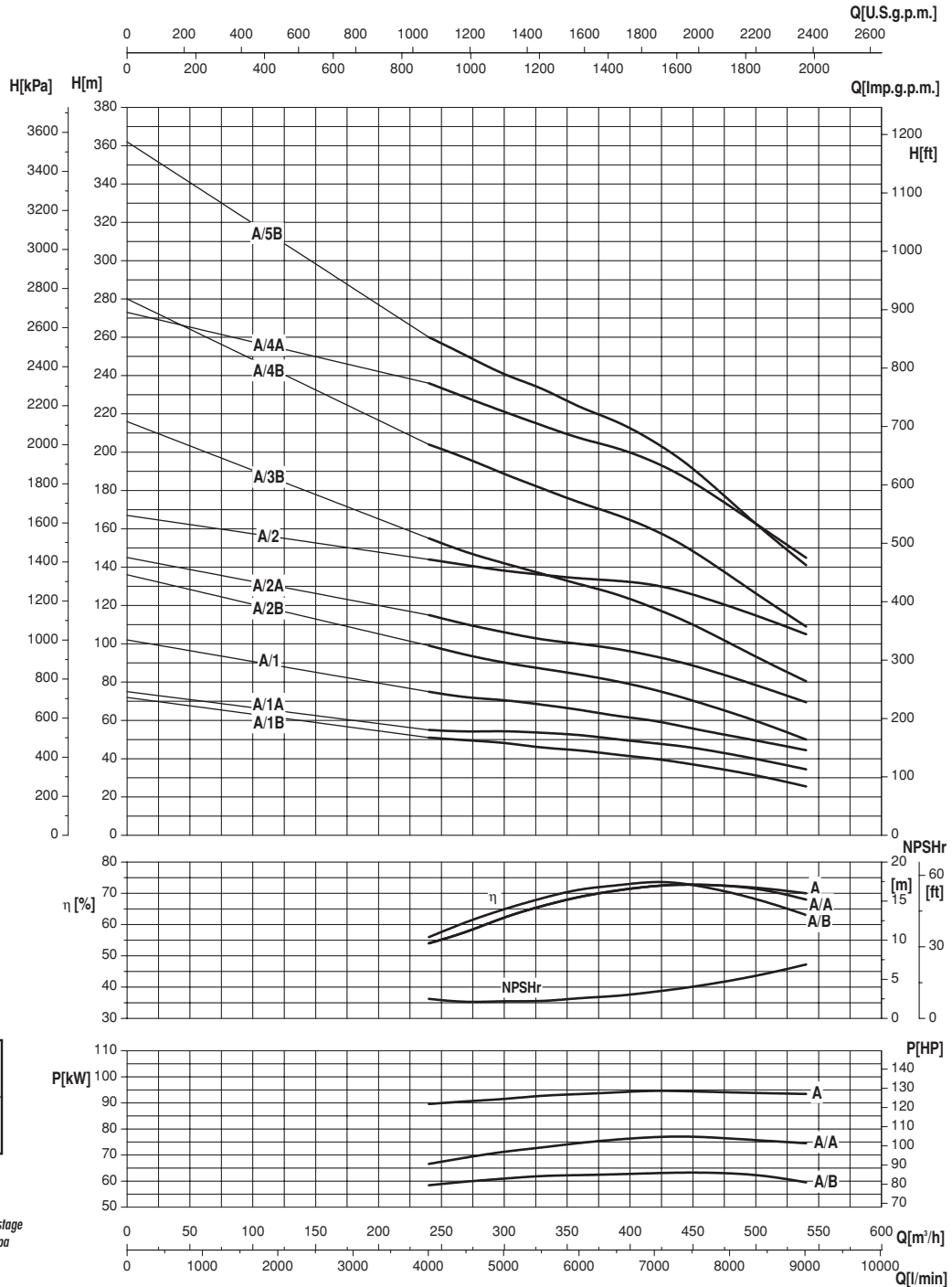

Moltiplicare il rendimento per il coefficiente corrispondente al vostro numero di stadi.

Multiply efficiency by the coefficient corresponding the number of stages.

Multiplicar el rendimiento por el coeficiente correspondiente a su numero de etapas.

Numero di stadi	1	2	3	>3
Number of stages	1	2	3	>3
Numero de etapas	1	2	3	>3
Coefficienti	0,97	0,98	0,99	1
Coefficiente	0,97	0,98	0,99	1

- Potenza assorbita per stadio
- Absorbed power for each single stage
- Potencia absorbida por cada etapa

Le curve di prestazione sono basate su valori di viscosità cinematica = 1 mm<sup>2</sup>/s e densità pari a 1000 kg/m<sup>3</sup>. Tolleranza e curve secondo UNI EN ISO 9906 - Appendice A • The performance curves are based on the kinematic viscosity values = 1 mm<sup>2</sup>/s and density equal to 1000 kg/m<sup>3</sup>. Tolerance and curves according to UNI EN ISO 9906 - Attachment A • Las curvas de rendimiento se refieren a valores de viscosidad cinemática = 1 mm<sup>2</sup>/s y densidad de 1000 Kg/m<sup>3</sup>. Tolerancia de las curvas de acuerdo con UNI EN ISO 9906 - Parrafo A.



12"

**SAER®**  
**ELETTROPOMPE**

# 6XS-302B

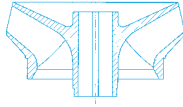
 $\cong 3600 \text{ l/min}$ 
**CARATTERISTICHE IDRAULICHE**
**HYDRAULIC FEATURES / CARACTERISTICAS HIDRAULICAS**

Tipo Type	Motore Motor		S.F.	I <sub>sf</sub> (A) 3~		U.S.g.p.m. Q	Flow Rate															
	kW	HP		380V			460V		m <sup>3</sup> /h													
									l/min													
6XS-302 B/1C *	60	80	1,15	139	115	H (m)	66	45	43	42	39,5	38	35	31,5	29	25	18					
6XS-302 B/1B *	75	100	1,15	174	143		69	47	46	45	42,5	41	38	35	31	27	18					
6XS-302 B/1A **	83	113	1,15	194	160		76	53	52	51	49	47	45	41	38	35	25					
6XS-302 B/1 *	110	150	1,15	247	204		82	67	65,5	64,5	62	60	58	54	51	48	40					
6XS-302 B/2C *	110	150	1,15	247	204		129	90	87	84,5	81,5	77	72	66	59	50	33					
6XS-302 B/2B *	150	200	1,15	329	272		142	100	97	94,5	91,5	89	84	78	71	64	48					
6XS-302 B/2A ***	170	230	1,15	375	310		156	122	119	114,5	110	108	102	96	90	80,5	64					
6XS-302 B/3C ***	170	230	1,15	375	310		194	136	132,5	126	122	116	108	99	88	75	50					
6XS-302 B/2 **	220	300	1,15	500	413		164	135	131,5	128,5	125	121	116	109	103	96	80					
6XS-302 B/3B **	220	300	1,15	500	413		204	154	150	144	139	132	125	118	108	97	73					
6XS-302 B/3A	260	350	1,15	580	479		236	182	177	171	167	159,5	152	143,5	133,5	120,5	96					
6XS-302 B/4B	300	400	1,15	655	541		272	205	199	191	185	175,5	166	156	144	130	98					
6XS-302 B/5C	300	400	1,15	655	541		332	240	229,5	219,5	210	200	187	172	155	136	102					
Livello minimo di battente alla griglia di aspirazione (m) • Min. hydrostatic head level to the suction grid (m) • Nivel de sumergencia min. de rejilla de aspiración (m)							2,5	3	3	4	4	5,5	5,5	6	6	6	6					

\* Funzionamento in orizzontale possibile. Si raccomanda la corretta posa dei supporti onde evitare che l'elettropompa lavori a sbalzo. • Horizontal operation is possible. The motor shall be correctly installed with the relative supports in order to ensure the electric pump works properly. • El funcionamiento en posición horizontal es posible. Se aconseja colocar correctamente los soportes oportunos para evitar que la electrobomba funcione en voladizo.

\*\* Funzionamento in orizzontale possibile con motore 10" MSX251-125. Si raccomanda la corretta posa dei supporti onde evitare che l'elettropompa lavori a sbalzo. • Horizontal operation is possible with 10" motor MSX251-125. The motor shall be correctly installed with the relative supports in order to ensure the electric pump works properly. • El funcionamiento en posición horizontal es posible con motor 10" motor MSX251-125. Se aconseja colocar correctamente los soportes oportunos para evitar que la electrobomba funcione en voladizo.

\*\*\* Funzionamento in orizzontale possibile con motore 12" MSX300-250. Si raccomanda la corretta posa dei supporti onde evitare che l'elettropompa lavori a sbalzo. • Horizontal operation is possible with 12" motor MSX300-250. The motor shall be correctly installed with the relative supports in order to ensure the electric pump works properly. • El funcionamiento en posición horizontal es posible con motor 12" MSX300-250. Se aconseja colocar correctamente los soportes oportunos para evitar que la electrobomba funcione en voladizo.

• Potenza nominale motore • Rated power of motor • Potencia nominal del motor

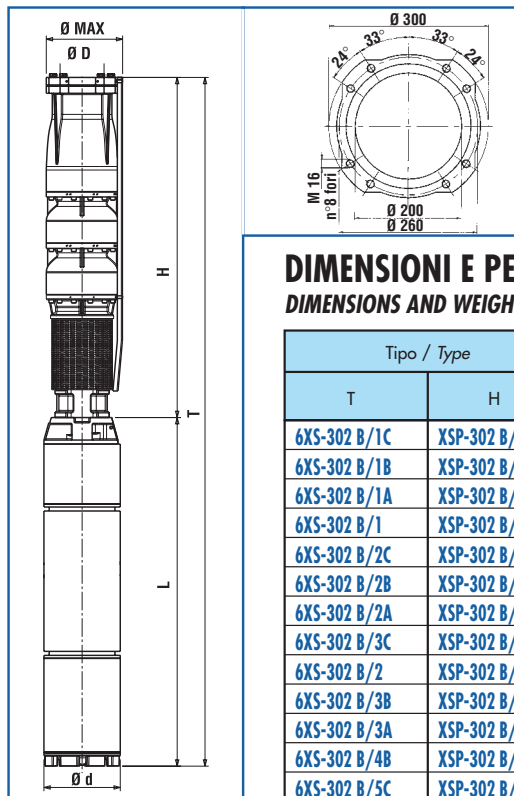
**DIMENSIONI E PESI**
**DIMENSIONS AND WEIGHT / DIMENSIONES Y PESOS**

Tipo / Type		T (mm)	H (mm)	L (mm)	Ø Max (mm)	Ø D "G	Ø d (mm)	Motore Motor	NEMA	Peso Weight (Kg)	
T	H									H	T
6XS-302 B/1C	XSP-302 B/1C	2090	955	1135	301	8"	192	8" MSX 201	1.18.424	130	314
6XS-302 B/1B	XSP-302 B/1B	2290	955	1335	301	8"	192	8" MSX 201	1.18.424	130	353
6XS-302 B/1A	XSP-302 B/1A	2370	955	1415	301	8"	192	8" MSX 201	1.18.424	130	369
6XS-302 B/1	XSP-302 B/1	2540	955	1585	301	8"	238	10" MSX 251	-	130	403
6XS-302 B/2C	XSP-302 B/2C	2735	1150	1585	301	8"	238	10" MSX 251	-	165	438
6XS-302 B/2B	XSP-302 B/2B	2720	1150	1570	301	8"	238	10" MSX 251	-	165	563
6XS-302 B/2A	XSP-302 B/2A	2950	1150	1800	301	8"	238	10" MSX 251	-	165	619
6XS-302 B/3C	XSP-302 B/3C	3145	1345	1800	301	8"	238	10" MSX 251	-	200	654
6XS-302 B/2	XSP-302 B/2	2910	1150	1760	301	8"	288	12" MSX 300	-	165	795
6XS-302 B/3B	XSP-302 B/3B	3105	1345	1760	301	8"	288	12" MSX 300	-	200	830
6XS-302 B/3A	XSP-302 B/3A	3255	1345	1910	301	8"	288	12" MSX 300	-	200	897
6XS-302 B/4B	XSP-302 B/4B	3600	1540	2060	301	8"	288	12" MSX 300	-	235	1000
6XS-302 B/5C	XSP-302 B/5C	3795	1735	2060	301	8"	288	12" MSX 300	-	270	1035



# SAER®

12"

ELETTROPOMPE

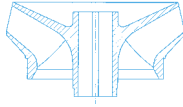

## 6XS-302B

≈ 3600 l/min

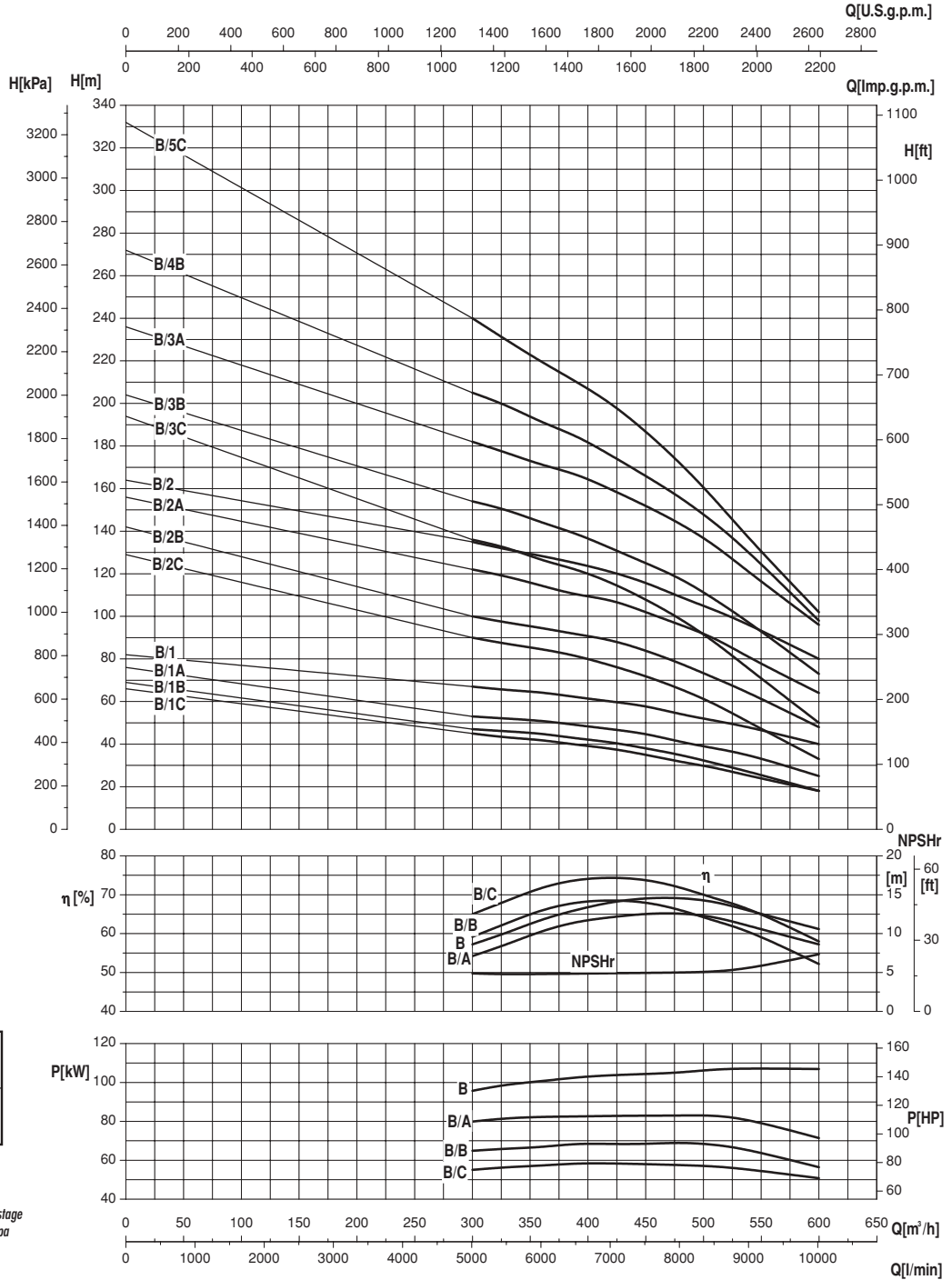

Moltiplicare il rendimento per il coefficiente corrispondente al vostro numero di stadi.

Multiply efficiency by the coefficient corresponding the number of stages.

Multiplicar el rendimiento por el coeficiente correspondiente a su numero de etapas.

Numero di stadi Number of stage Numero de etapas	1	2	3	>3
Coefficienti Coefficient Coeficiente	0,97	0,98	0,99	1

- Potenza assorbita per stadio
- Absorbed power for each single stage
- Potencia absorbida por cada etapa

Le curve di prestazione sono basate su valori di viscosità cinematica = 1 mm<sup>2</sup>/s e densità pari a 1000 kg/m<sup>3</sup>. Tolleranza e curve secondo UNI EN ISO 9906 - Appendice A • The performance curves are based on the kinematic viscosity values = 1 mm<sup>2</sup>/s and density equal to 1000 kg/m<sup>3</sup>. Tolerance and curves according to UNI EN ISO 9906 - Attachment A • Las curvas de rendimiento se refieren a valores de viscosidad cinemática = 1 mm<sup>2</sup>/s y densidad de 1000 Kg/m<sup>3</sup>. Tolerancia de las curvas de acuerdo con UNI EN ISO 9906 - Parrafo A.