

## Progressive Cavity Pumps with Force Feed Screw IVA range

### Fields of application

This range of pumps are used in all branches of Industry :

Building,  
Ceramics,  
Chemical,  
Edible oil industry,

Mining,  
Oil,  
Paper industry,  
Petrochemical,  
Sewage treatment,  
Soap factories,

Starch factories,  
Sugar refineries.

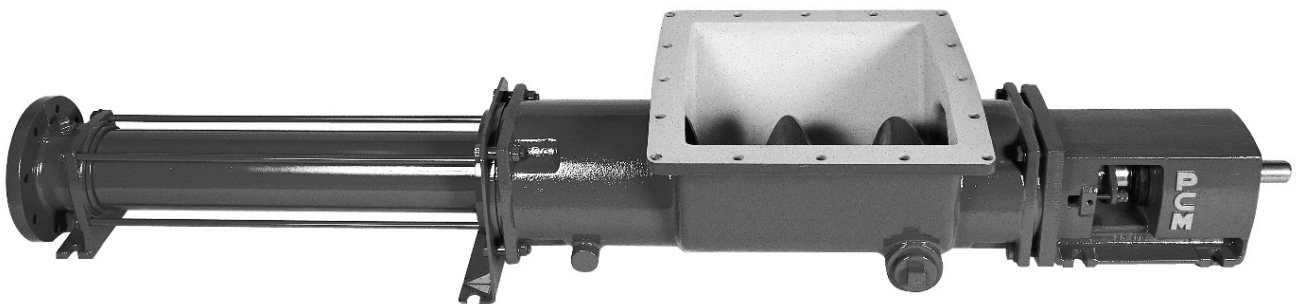

### Benefits

Non-pulsating flow,  
Flow directly proportional to speed,  
High self-priming capability,  
High efficiency,  
Operates without valves,

Simple and heavy duty construction,  
Easy maintenance.

### IVA range

Specially designed to handle heterogeneous and highly viscous products (up to 1 000 000 cPo), the MOINEAU IVA pumps are equipped with

one or two force feed screws and a wide throat inlet.

### Performances

**Capacity**  
Up to 300 m<sup>3</sup>/h.

**Discharge pressure**  
Up to 45 bar in standard version and up to 200 bar on request.

**Temperature**  
From 0 °C to + 110 °C  
higher temperature on request.

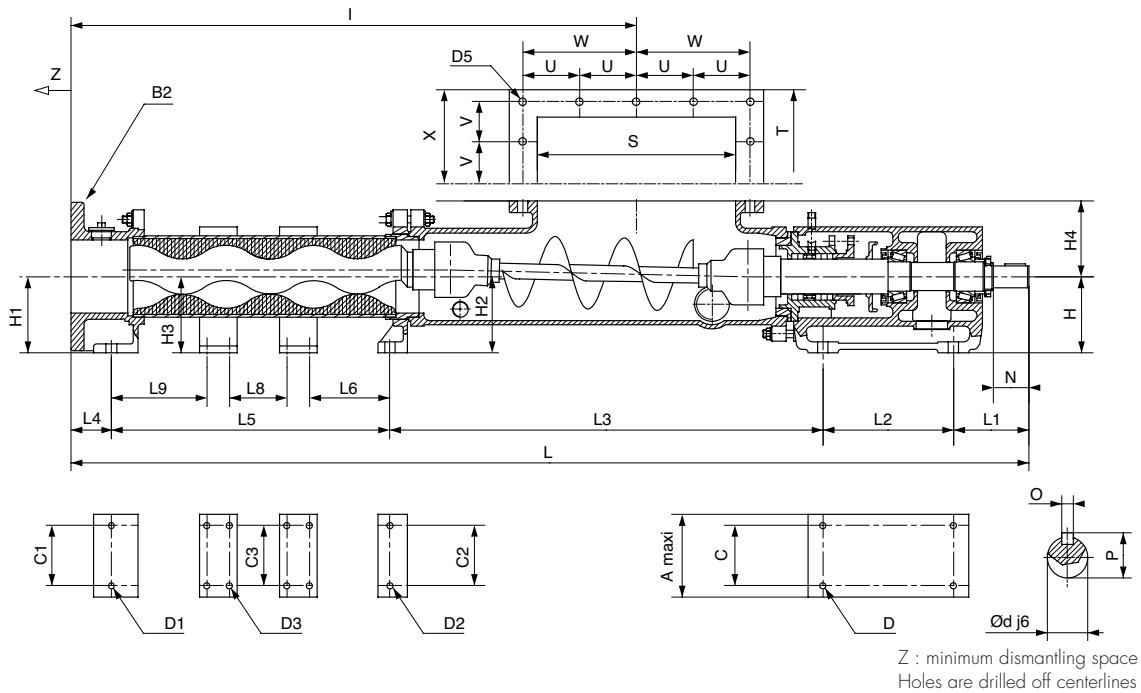

## Design features

### Body

The pump body is of A48 N°40 cast-iron or AISI 316L stainless steel construction. Special material available on request.

Inspection port, double casing for heating or cooling are also available.

### Rotor

Depending on the product to be pumped, the rotor can be made of hardened steel, AISI 316L stainless steel, with or without chrome plating. Other material are available.

### Stator

Stators are moulded to metal casings and can be made of nitrile, ethylene propylene, hypalon, viton, neoprene or natural rubber of various shore hardness. Cast iron and tufnol stators are also available.

### Rotating parts

According to rotor material and pumped product, rotating parts can be made of metallized steel, AISI 316 stainless steel, AISI 420 stainless steel, with or without chrome plating. Other material are available.

### Bearings

The bearing housing is made of cast iron.

The shaft is supported by two high capacity bearings, greased for life.

### Shaft seals

A comprehensive range of packed gland, single or double mechanical seal is available to suit all duty conditions.

### Drives

Electric motor, diesel/petrol engine, hydraulic motor, geared motor, variable speed geared motor, frequency inverter, d.c motor are available.

### Options

Circulating by-pass, dry running protection device, relief valve, capacity and pressure control device and many other accessories are available.

I VA Range	Mounting									Dimensions													
	Size	A maxi	C	CI/SS		C3	D	D1	D2	D3	H	H3	H4	I	L	L1	L2	L6	L7	L8	L9	Z	HT
1.6 IVA 45	170	140	60			16	16			130		125	890	1550	129	224						470	77
2.6 IVA 10	116	80	60/0			16	16			90		100	502	873	177							160	90
* 4 IVA 52																							
6 IVA 5	116	80	60/0			16	16			90		100	422	791	177							120	90
6 IVA 10	140	95	70/70	70		14	14	16		112		100	684	1130	220							C1196 SS200	112
6 IVA 20	140	95	70/70	70		14	14	16		112		100	937	1383	220							450	112
13 IVA 5	140	95	70/70	70		14	14	16		112		100	624	1070	220							130	112
13 IVA 10	140	95	70/70	70		14	14	16		112		100	833	1279	220							340	112
13 IVA 20	180	140	140	140		18	16	18		130		130	1282	1956	129	224						700	125
20 IVA 16	180	140	140	140		18	16	16		130		180	C11586 SS1580	C12383 SS2376	129	224						980	125
20 IVA 20	250	220	200	200		20	24	24		180		180	1642	2573	168	295						1050	140
20 IVA 40	350	220	200	200	310	20	24	24	20	180		180	2657	3588	168	295						1850	140
25 IVA 5	180	140	140	140		18	16	18		125		130	730	1373	115	224						185	125
25 IVA 10	180	140	140	140		18	16	18		130		130	1014	1685	129	224						470	125
35 IVA 20	250	220	200	200		20	24	24		180		180	1855	2785	168	295						1160	140
* 35 IVA 40																							
40 IVA 10	260	140	140	230		18	16	22		130		180	1375	2170	129	224						700	130
45 IVA 5	260	140	140	230		18	16	22		130		180	990	1787	129	224						305	130
50 IVA 15	280	220	200	230		20	22	22		180		210	2307	3280	168	295						1400	160
50 IVA 30	660	250	210	210	600	26	34	34	26	250		210	3722	4971	282	320	1461	80	1472	0	2720	250	
60 IVA 10	250	220	200	200		20	22	22		180		180	1635	2565	168	295						890	160
62 IVA 5	185	140	120	120		18	18	18		130		180	1115	1913	129	224						390	130
100 IVA 10	280	220	230	230		20	22	22		180		210	2050	3100	168	295						1130	180
*100 IVA 20																							
120 IVA 5	280	220	230	230		20	22	22		180		210	1390	2408	168	295						600	180
150 IVA 10	280	220	230	230		20	22	22		180		210	2570	3620	168	295						1650	180
*150 IVA 20																							
180 IVA 5	280	220	230	230		20	22	22		180		210	2018	3030	168	295						1200	180
240 IVA 5	320	220	240	240		20	26	26		180		280	2215	3193	168	295						1200	250
240 IVA 10	660	250	320	320	600	26	32	32	30	250		250	3250	4517	282	320	1180	80	180		2300	250	
500 IVA 5	440	250	360	360		26	40	40		250		350	2705	4108	282	320						900	300

\* Drawing available on request

All dimensions given for guidance are for only, PCM POMPES reserves the right to change specifications without notice.



## Curves

The indicated speeds and pressures are related to pumps handling water at 20 °C or fluid of the same viscosity. Operating speed is affected by abrasion and viscosity.

The operating conditions, accuracy, service, NPSH available must be examined to determine the most suitable pump for your application.

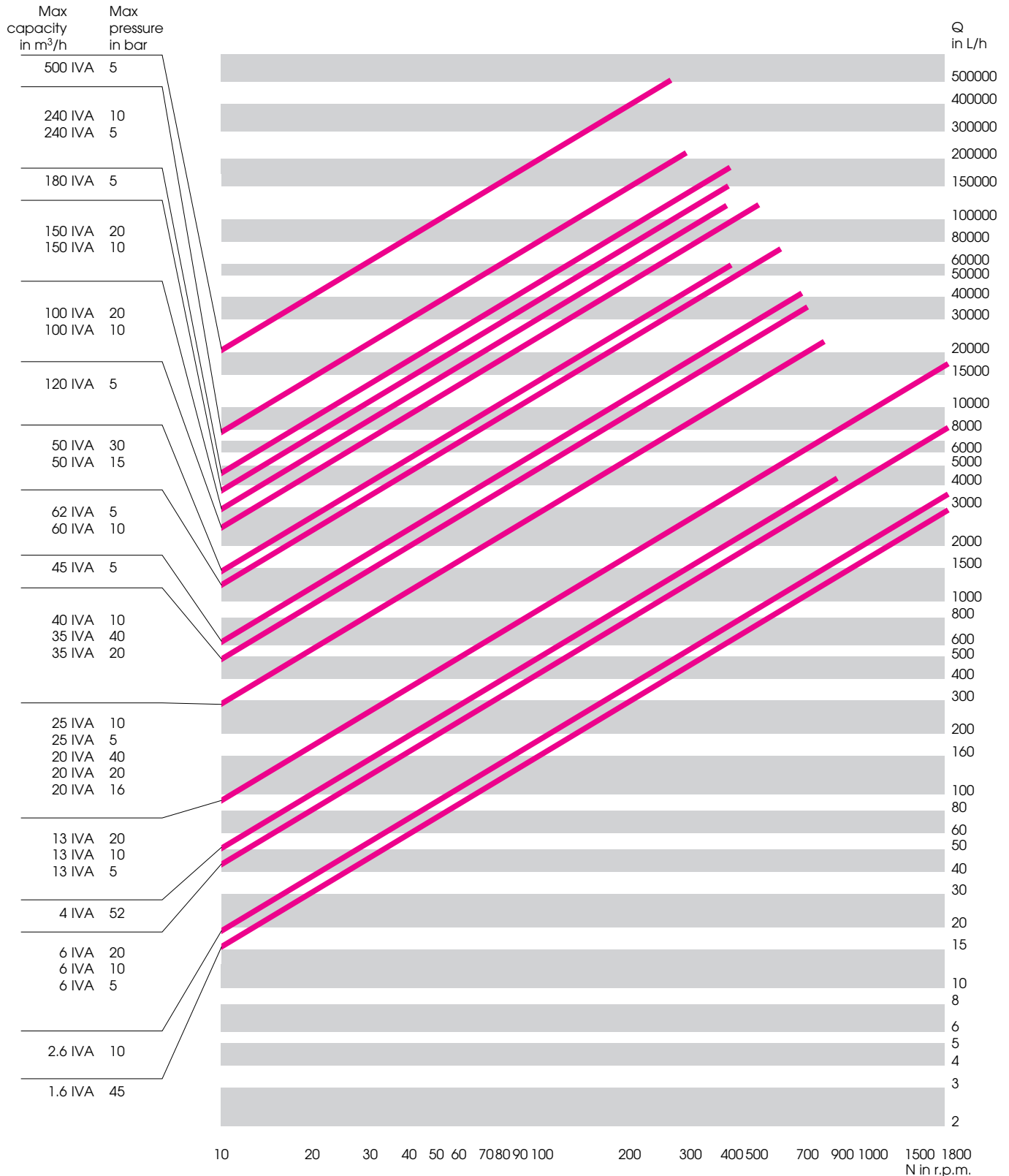

## Arrangements

Pump driven by geared motor with coupling on base frame.



Pump driven by variable speed geared motor with coupling on base frame.

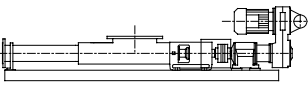

Pump driven by electric-motor and V-belt, on base frame.

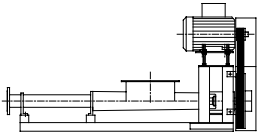

Pump driven by engine, with coupling and clutch, on base frame.

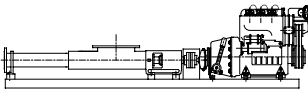

## MR/MV-I VA and MR/MV-ID VA range

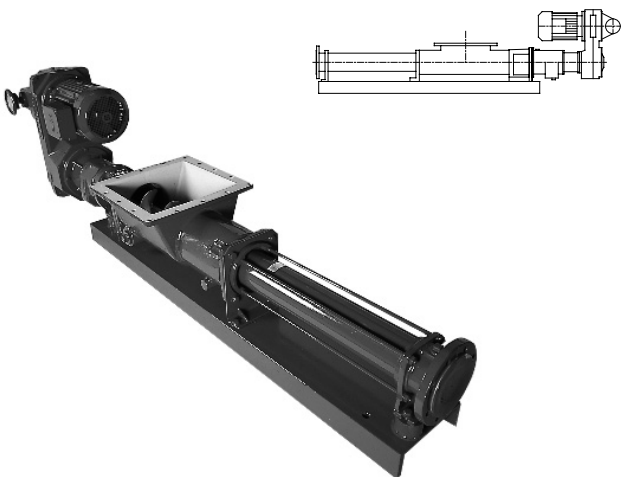

## Shaft sealing options

### Packed gland

A simple, low-cost and easy-to-maintain sealing arrangement.

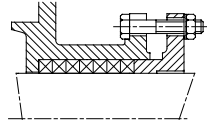

### Packed gland with flushing and lantern ring

A low-cost packing arrangement for sealing abrasive products.

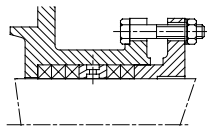

### Single mechanical seal

Provides long life and leak-free sealing. Balanced, single acting with capsulated spring. To suit the required service, a variety of seal material are available : ceramic/carbon, silicon carbide/silicon carbide, etc...

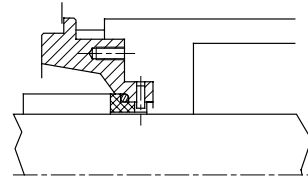

### Single mechanical seal with quench

Identical to single mechanical seal. Quench fluid cools seal, washes leakage away, prevents crystallization of leakage and dry running.

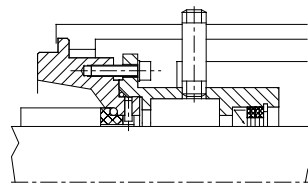

### Mechanical seal in tandem arrangement

Using clean liquid, pressurized or not, between the two mechanical seals. Suitable for abrasive liquids, toxic and hazardous fluids as well as high vapor pressure fluids.

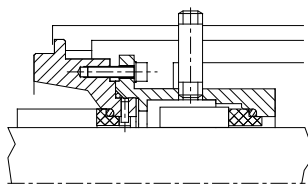

### Special seal arrangement

Other seal arrangements are available on request for special application :

- back to back arrangement,
- outside arrangement.

**motralec**

4 rue Lavoisier . ZA Lavoisier . 95223 HERBLAY CEDEX

Tel. : 01.39.97.65.10 / Fax. : 01.39.97.68.48

Demande de prix / e-mail : [service-commercial@motralec.com](mailto:service-commercial@motralec.com)

[www.motralec.com](http://www.motralec.com)