

# MP PUMPS, INC.

## PETROLEUM 80

### End Suction Centrifugal Pump

Specifically designed for petroleum based fluids, MP's *Petroleum 80* series is available in three (3) distinct models: **SO 80**, **SG 80** and **SE 80**.

Designed to close-couple to 56C and 145TC frame electric motors, the models are also available as *Pumpaks*. Additional mounting options include pedestal.

Pump rotation in 90° increments.



### SPECIFICATIONS:

Suction and Discharge . . . . .	1 1/2" x 1 1/4" NPT 150# Flange
Housing . . . . .	SO 80 . . . Cast Iron, Ductile Iron (optional) SG 80 . . . Ductile Iron SE 80 . . . Ductile Iron
Impeller, Enclosed . . .	SO 80 . . . Cast Iron SG 80 . . . Aluminum SE 80 . . . Cast Iron
Mechanical Seal . . .	SO 80 . . . Type 21 Viton/Carbon/NiResist/SS SG 80 . . . Type 2 Viton/Carbon/Silicon Carbide/SS SE 80 . . . Type 2 Viton/Carbon/Silicon Carbide/SS
Gasket, Flange . . . . .	Composite
Shaft Sleeve . . . . .	Stainless Steel
Fasteners . . . . .	Stainless Steel
Clamp, Shaft . . . . .	Brass, Lead-Free

### COMPATIBLE FOR:

- **SO 80** - Biodiesel, Fuel Oil, Diesel
- **SG 80** - Gasoline, Avgas, Kerosene, Jet A/8
- **SE 80** - Ethanol, E 85

### MOUNTING OPTIONS:

Pedestal Or Close Coupled To Nema C Face Motors

- **SO 80** - TEFC
- **SG 80** - Explosion Proof Class 1 Group D
- **SE 80** - Explosion Proof Class 1 Group D

### PERFORMANCE TO:

80 GPM 129 HD. FT. @ 3450 RPM

**motralec**

4 rue Lavoisier . ZA Lavoisier . 95223 HERBLAY CEDEX  
Tel. : 01.39.97.65.10 / Fax. : 01.39.97.68.48  
Demande de prix / e-mail : [service-commercial@motralec.com](mailto:service-commercial@motralec.com)

[www.motralec.com](http://www.motralec.com)

# PETROLEUM 80

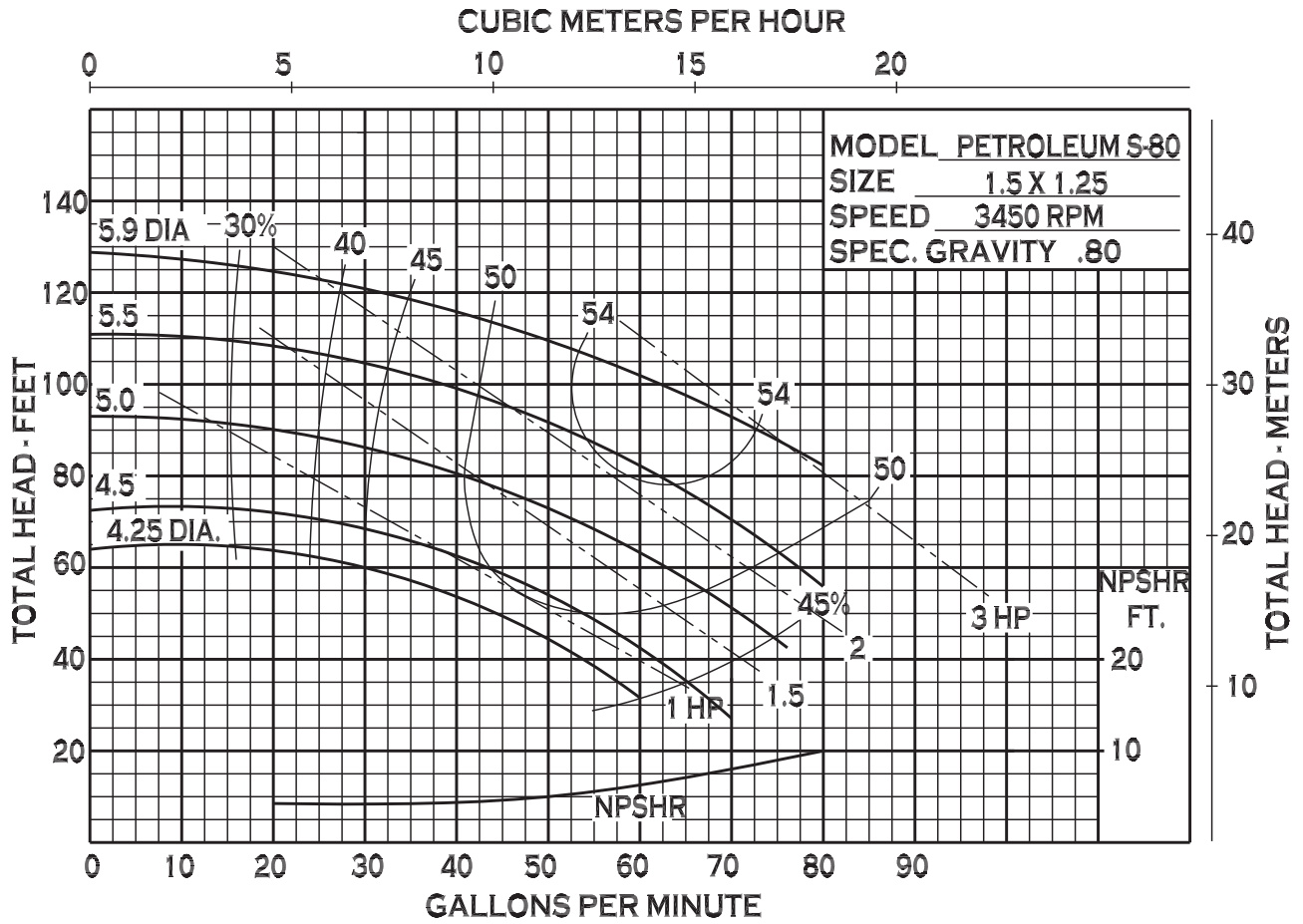

## PEDESTAL-MOUNT

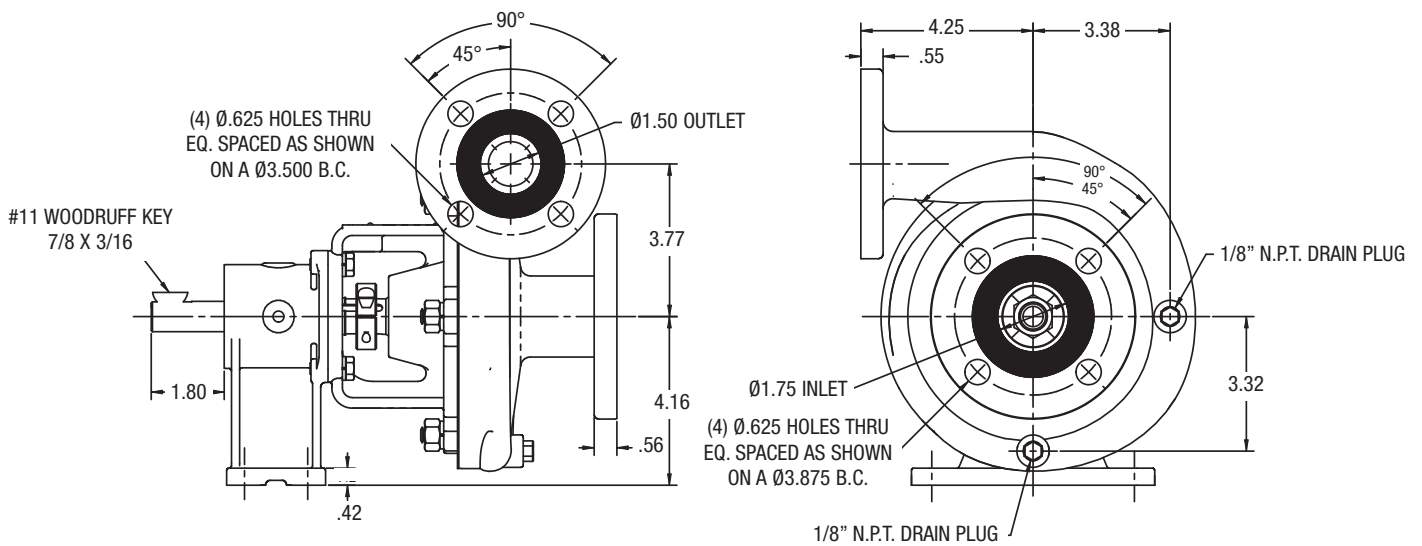

## CLOSE COUPLED - ELECTRIC MOTOR

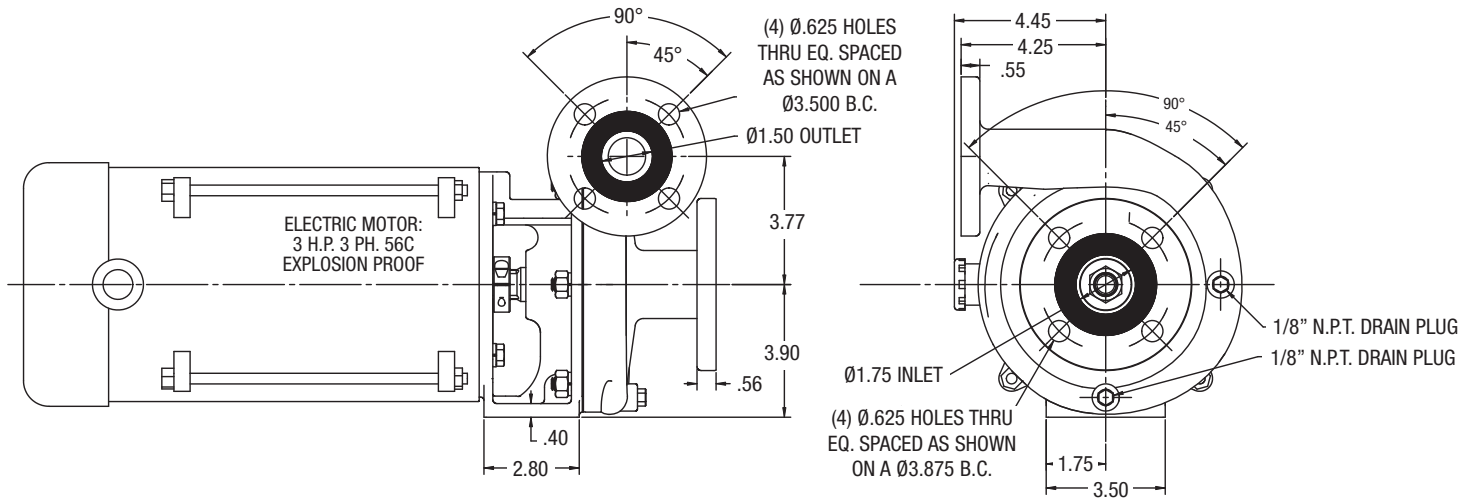

## CLOSE COUPLED - ELECTRIC MOTOR

