

POMPE AUTOADESCANTI AD ANELLO LIQUIDO

LIQUID RING SELF PRIMING PUMPS



CATALOGO
TECNICO

TECHNICAL
CATALOGUE

motralec

4 rue Lavoisier . ZA Lavoisier . 95223 HERBLAY CEDEX
Tel. : 01.39.97.65.10 / Fax. : 01.39.97.68.48
Demande de prix / e-mail : service-commercial@motralec.com
www.motralec.com

LIVERANI

INDICE/CONTENTS

■ ■ ■ Tipologia pompe

| | |
|--|------|
| <i>Pump range</i> | 2-19 |
| Pompe Special | 2 |
| <i>Special pump type</i> | 2 |
| Pompe Special con frizione magnetica | 4 |
| <i>Special pump type with magnetic clutch</i> | 4 |
| Pompe Nautic | 6 |
| <i>Nautic pump type</i> | 6 |
| Pompe Nautic con frizione manuale | 8 |
| <i>Nautic pump type with hand clutch</i> | 8 |
| Pompe MID per motori idraulici | 10 |
| <i>MID pump type for hydraulic motors</i> | 10 |
| Pompe Lalx con moltiplicatore | 12 |
| <i>Lalx pump type with overdrive</i> | 12 |
| Elettropompe in bronzo | 14 |
| <i>Bronze electric pumps</i> | 14 |
| Elettropompe in acciaio inox AISI 316 | 16 |
| <i>Stainless steel AISI 316 electric pumps</i> | 16 |
| Gruppi antideflagranti senza impianto elettrico | 18 |
| <i>Explosion proof groups without control panels</i> | 18 |

■ ■ ■ Tabella raccordi acciaio inox

| | |
|--|----|
| <i>Stainless steel pipe fittings table</i> | 20 |
|--|----|

■ ■ ■ Accessori

| | |
|--|----|
| <i>Accessories</i> | 21 |
| Carrelli e maniglie per elettropompe | 21 |
| <i>Trolley and handle for electric pumps</i> | 21 |
| Valvola by-pass | 21 |
| <i>Bypass valve</i> | 21 |
| Interruttore/invertitore - morsettiera | 21 |
| <i>On-off/reverse switch - terminal board connection</i> | 21 |

■ ■ ■ Componenti

| | |
|--------------------------|-------|
| <i>Spare parts</i> | 22-29 |
|--------------------------|-------|

POMPE SPECIAL

SPECIAL PUMP TYPE



SPECIAL 20-25-30-40-50



SPECIAL SENIOR 1 1/2-MASTER 2"

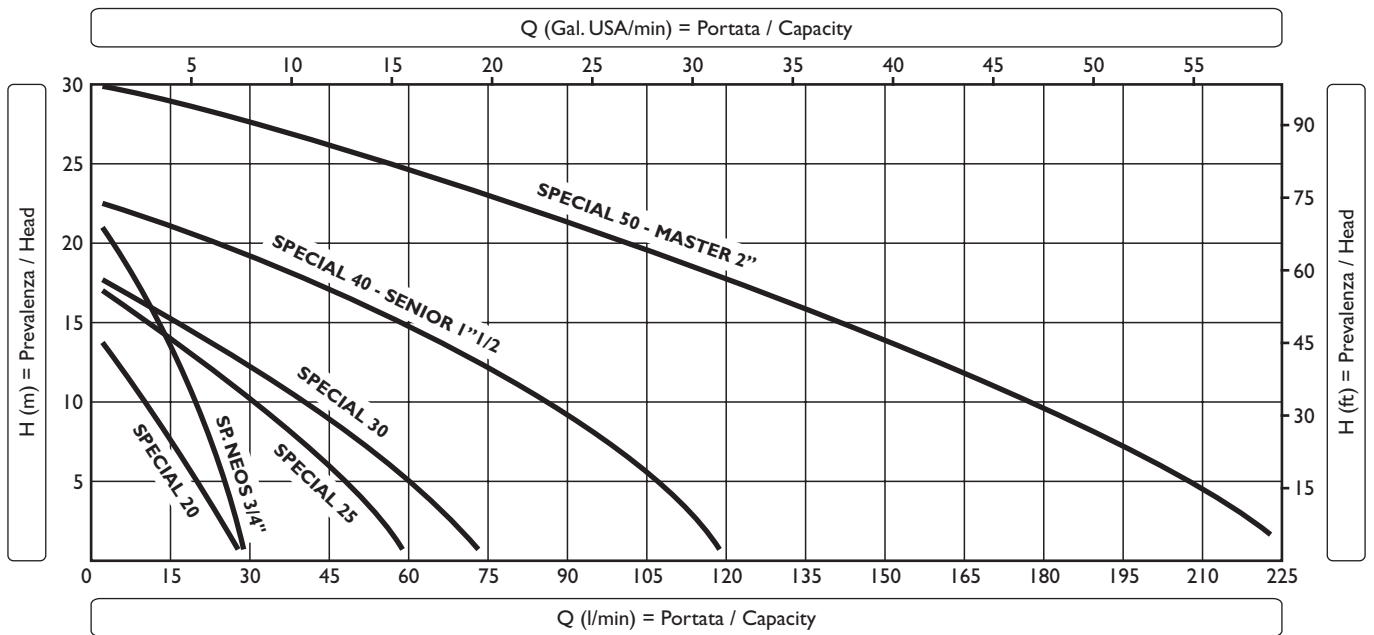

| Tipo Type | Codice Code | Materiale Material | Peso Weight | Giri/min Rpm | H (m) = Prevalenza / Head - Q (l/min) = Portata / Capacity | | | | | | | | | | | |
|-----------------------------|----------------|-----------------------|----------------|-----------------|--|-----|-----|-----|-----|-----|----|----|----|---|--|---|
| | | | | | 0 | 5 | 10 | 12 | 15 | 18 | 22 | 28 | 30 | H | | |
| SPECIAL 20 | 51072000 | Bronzo/Bronze | 2,0 kg | 2800 | 29 | 20 | 10 | 6 | 0 | | | | | | | Q |
| SPECIAL 25 | 51072500 | Bronzo/Bronze | 2,8 kg | 2800 | 60 | 50 | 25 | 15 | 8 | 0 | | | | | | |
| SPECIAL 30 | 51073000 | Bronzo/Bronze | 5,6 kg | 1400 | 75 | 60 | 40 | 30 | 15 | 0 | | | | | | |
| SPECIAL 40 | 51074000 | Bronzo/Bronze | 7,3 kg | 1400 | 120 | 110 | 85 | 80 | 55 | 45 | 0 | | | | | |
| SPECIAL 50 | 51075000 | Bronzo/Bronze | 12,5 kg | 1400 | 230 | 210 | 175 | 155 | 140 | 125 | 85 | 45 | 0 | | | |
| SPECIAL NEOS 3/4" | 60070500 | Inox AISI 316 | 1,8 kg | 2800 | 29 | 23 | 17 | 14 | 13 | 8 | 0 | | | | | |
| SPECIAL SENIOR 1 1/2 | 60074000 | Inox AISI 316 | 7,4 kg | 1400 | 120 | 110 | 85 | 80 | 55 | 45 | 0 | | | | | |
| SPECIAL MASTER 2" | 60075000 | Inox AISI 316 | 12,6 kg | 1400 | 230 | 210 | 175 | 155 | 140 | 125 | 85 | 45 | 0 | | | |

SPECIAL NEOS 3/4"

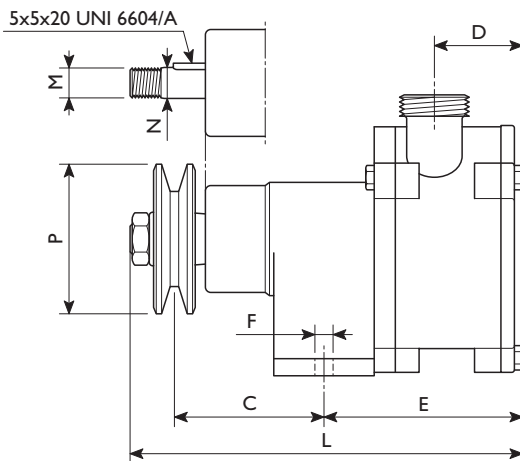
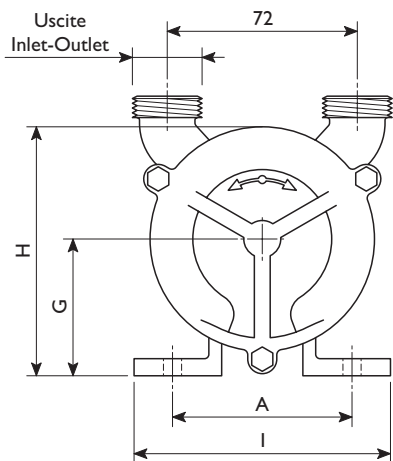

SPECIAL 20-25

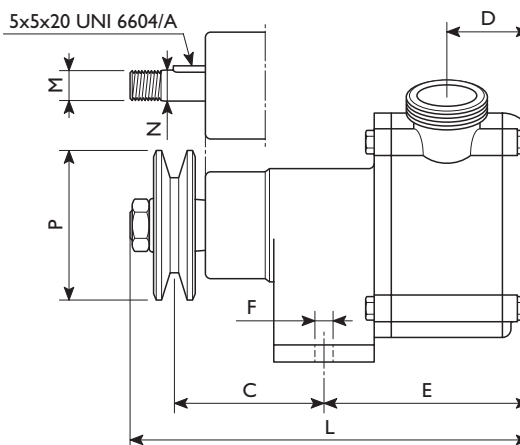
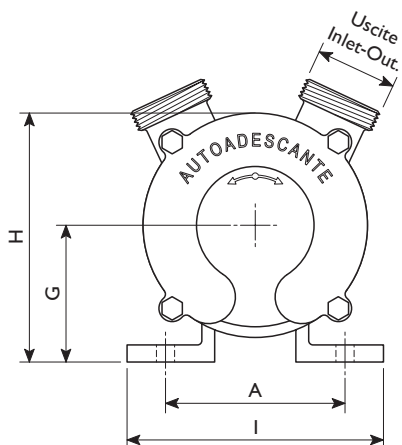

**SPECIAL 30-40-50
SPECIAL SENIOR 1" 1/2
SPECIAL MASTER 2"**

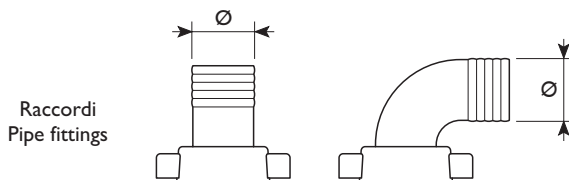
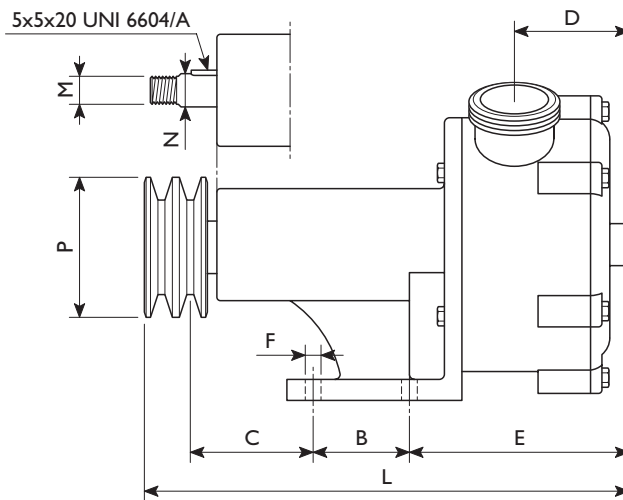
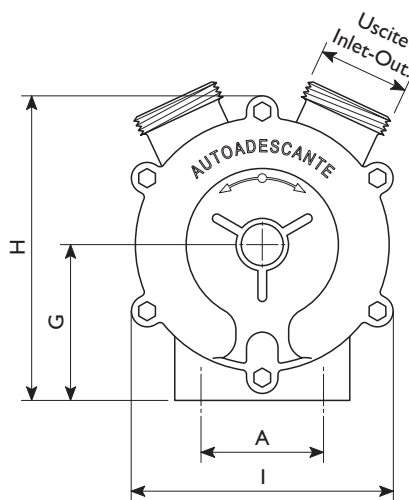

| Tipo Type | Uscite Inlet-Outlet | Raccordi Pipe fittings | Dimensioni (mm) / Dimensions (mm) | | | | | | | | | | | | |
|------------------------------|------------------------|---------------------------|-----------------------------------|----|----|----|-----|------|-----|-----|-----|-----|---------|-------|--------|
| | | | A | B | C | D | E | F | G | H | I | L | M | N | P |
| SPECIAL 20 | BSP-M 3/4" | Ø20 | 84 | - | 70 | 35 | 81 | Ø8.5 | 56 | 100 | 120 | 172 | M14x1.5 | Ø14.5 | Ø70x1A |
| SPECIAL 25 | BSP-M 1" | Ø25 | 84 | - | 70 | 40 | 98 | Ø8.5 | 56 | 108 | 120 | 190 | M14x1.5 | Ø14.5 | Ø70x1A |
| SPECIAL 30 | BSP-M 1" 1/4 | Ø30 - Ø35 | 70 | 55 | 64 | 50 | 103 | Ø8.5 | 89 | 175 | 150 | 254 | M16 | Ø19 | Ø70x1A |
| SPECIAL 40 | BSP-M 1" 1/2 | Ø40 - Ø45 | 70 | 55 | 64 | 67 | 128 | Ø8.5 | 89 | 175 | 150 | 277 | M16 | Ø19 | Ø80x2A |
| SPECIAL 50 | BSP-M 2" | Ø50 | 70 | 55 | 90 | 90 | 160 | Ø9 | 107 | 210 | 185 | 330 | M16 | Ø19 | Ø80x2A |
| SPECIAL NEOS 3/4" | BSP-M 3/4" * | Ø20 ** | 84 | - | 70 | 34 | 80 | Ø8.5 | 56 | 210 | 185 | 171 | M14x1.5 | Ø14.5 | Ø70x1A |
| SPECIAL SENIOR 1" 1/2 | BSP-M 1" 1/2 * | Ø40 ** | 70 | 55 | 64 | 76 | 138 | Ø8.5 | 89 | 175 | 167 | 287 | M16 | Ø19 | Ø80x2A |
| SPECIAL MASTER 2" | BSP-M 2" * | Ø50 ** | 70 | 55 | 90 | 94 | 165 | Ø9 | 107 | 210 | 205 | 335 | M16 | Ø19 | Ø80x2A |

ISO R 52-253

* = Uscite standard BSP (Gas), altre uscite disponibili p.20 / Standard inlet-outlet BSP (Gas), different inlet-outlet are available see p.20
 ** = Raccordi in acciaio inox o nylon a richiesta / Stainless steel or nylon pipe fittings on request

POMPE SPECIAL CON FRIZIONE MAGNETICA

SPECIAL PUMP TYPE WITH MAGNETIC CLUTCH



SPECIAL 30-40-50 FM



SPECIAL SENIOR 1"1/2 FM
SPECIAL MASTER 2" FM



NAUTIC 70 FM

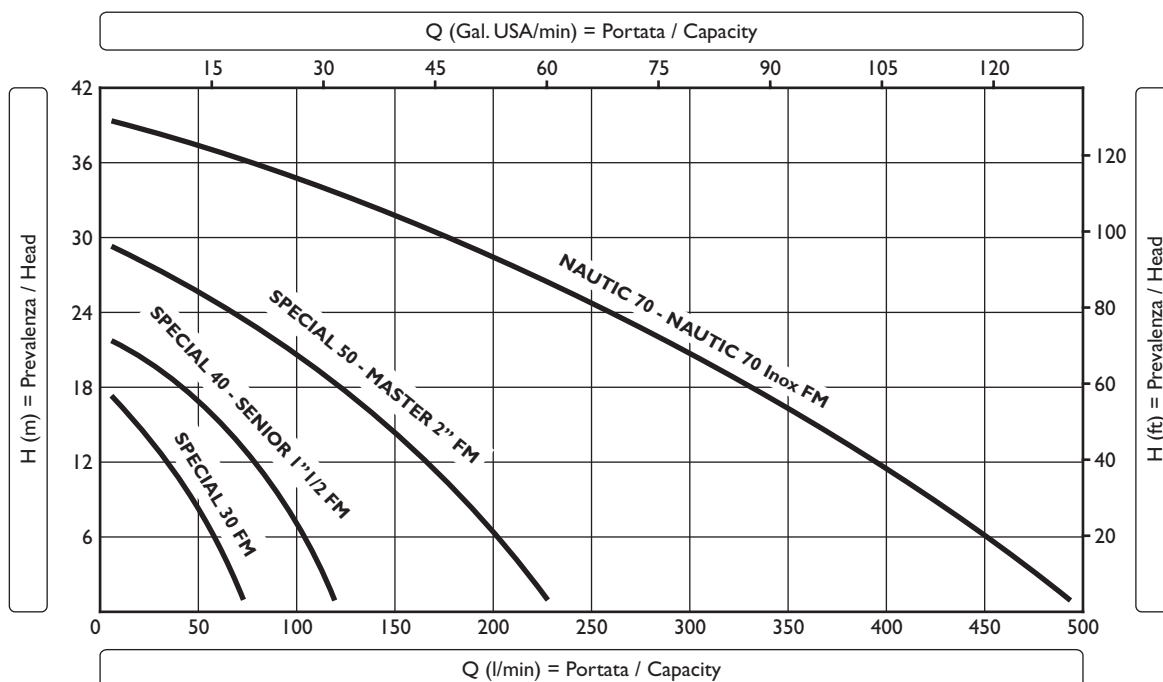

| Tipo Type | Codice / Code | | Materiale Material | Peso Weight | Giri/min Rpm | H (m) = Prevalenza / Head - Q (l/min) = Portata / Capacity | | | | | | | | | | | |
|--------------------------------|---------------|----------|-----------------------|----------------|-----------------|--|-----|-----|-----|-----|-----|-----|-----|-----|----|---|--|
| | FM 12V | FM 24V | | | | 0 | 5 | 10 | 12 | 15 | 18 | 22 | 28 | 30 | 40 | H | |
| SPECIAL 30 FM | 51073033 | 51073034 | Bronzo/Bronze | 9,8 kg | 1400 | 75 | 60 | 40 | 30 | 15 | 0 | | | | | | |
| SPECIAL 40 FM | 51074033 | 51074034 | Bronzo/Bronze | 10,3 kg | 1400 | 120 | 110 | 85 | 80 | 55 | 45 | 0 | | | | | |
| SPECIAL 50 FM | 51075033 | 51075034 | Bronzo/Bronze | 16,1 kg | 1400 | 230 | 210 | 175 | 155 | 140 | 125 | 85 | 45 | 0 | | | |
| NAUTIC 70 FM | 51137033 | 51137034 | Bronzo/Bronze | 28,8 kg | 1400 | 500 | 460 | 415 | 400 | 370 | 330 | 280 | 230 | 165 | 0 | | |
| SPECIAL SENIOR 1"1/2 FM | 60074033 | 60074034 | Inox AISI 316 | 10,4 kg | 1400 | 120 | 110 | 85 | 80 | 55 | 45 | 0 | | | | | |
| SPECIAL MASTER 2" FM | 60075033 | 60075034 | Inox AISI 316 | 16,2 kg | 1400 | 230 | 210 | 175 | 155 | 140 | 125 | 85 | 45 | 0 | | | |
| NAUTIC 70 Inox FM | 60137033 | 60137034 | Inox AISI 316 | 28,8 kg | 1400 | 500 | 460 | 415 | 400 | 370 | 330 | 280 | 230 | 165 | 0 | | |

SPECIAL 30-40-50 FM
SPECIAL SENIOR 1"1/2 FM
SPECIAL MASTER 2" FM

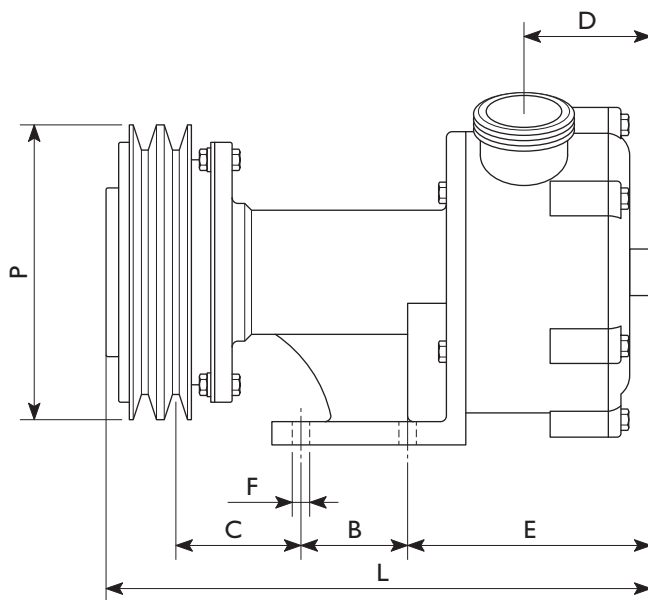
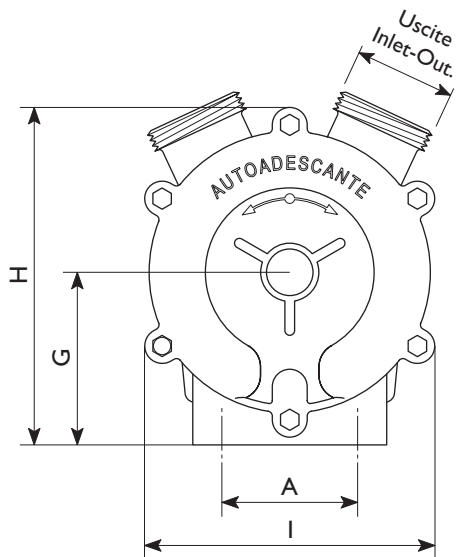

NAUTIC 70 FM

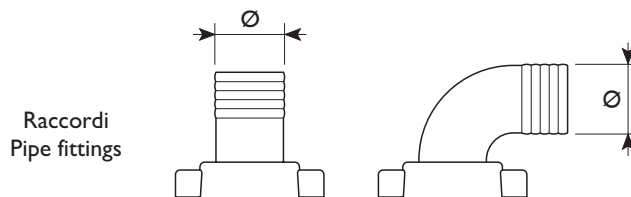
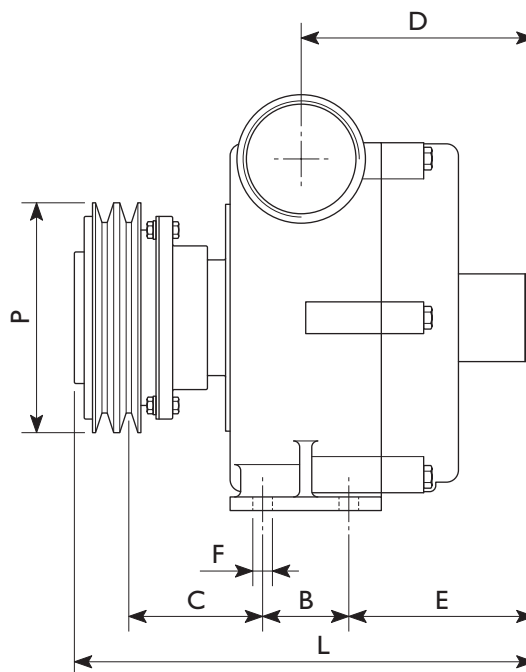
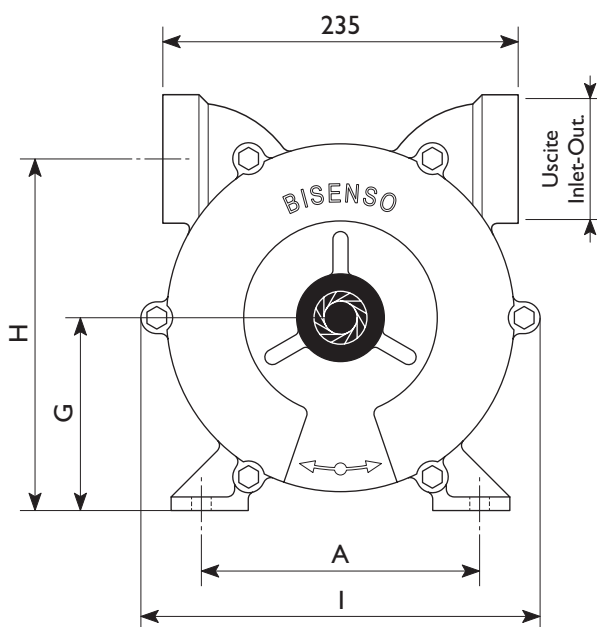

| Tipo Type | Uscite Inlet-Outlet | Raccordi Pipe fittings | Dimensioni (mm) / Dimensions (mm) | | | | | | | | | | |
|--------------------------------|------------------------|---------------------------|-----------------------------------|----|----|-----|-----|------|-----|-----|-----|-----|---------|
| | | | A | B | C | D | E | F | G | H | I | L | P |
| SPECIAL 30 FM | BSP-M 1"1/4 | Ø30 - Ø35 | 70 | 55 | 68 | 50 | 103 | Ø8,5 | 89 | 175 | 150 | 265 | Ø152x2A |
| SPECIAL 40 FM | BSP-M 1"1/2 | Ø40 - Ø45 | 70 | 55 | 68 | 67 | 128 | Ø8,5 | 89 | 175 | 150 | 288 | Ø152x2A |
| SPECIAL 50 FM | BSP-M 2" | Ø50 | 70 | 55 | 94 | 90 | 160 | Ø9 | 107 | 210 | 185 | 345 | Ø152x2A |
| NAUTIC 70 FM | BSP-F 2"1/2 | n.d. | 184 | 57 | 89 | 144 | 110 | Ø13 | 128 | 231 | 185 | 286 | Ø152x2A |
| SPECIAL SENIOR 1"1/2 FM | BSP-M 1"1/2 * | Ø40 ** | 70 | 55 | 68 | 76 | 138 | Ø8,5 | 89 | 175 | 167 | 298 | Ø152x2A |
| SPECIAL MASTER 2" FM | BSP-M 2" * | Ø50 ** | 70 | 55 | 94 | 94 | 165 | Ø9 | 107 | 210 | 205 | 350 | Ø152x2A |
| NAUTIC 70 Inox FM | BSP-M 2"1/2 | n.d. | 184 | 57 | 89 | 144 | 110 | Ø13 | 128 | 231 | 185 | 286 | Ø152x2A |

ISO R 52-253

* = Uscite standard BSP (Gas), altre uscite disponibili p.20 / Standard inlet-outlet BSP (Gas), different inlet-outlet are available see p.20
 ** = Raccordi in acciaio inox o nylon a richiesta / Stainless steel or nylon pipe fittings on request
 n.d. = Raccordi non disponibili / Pipe fittings not available

POMPE NAUTIC

NAUTIC PUMP TYPE



NAUTIC 25-30-40-50



NAUTIC 70

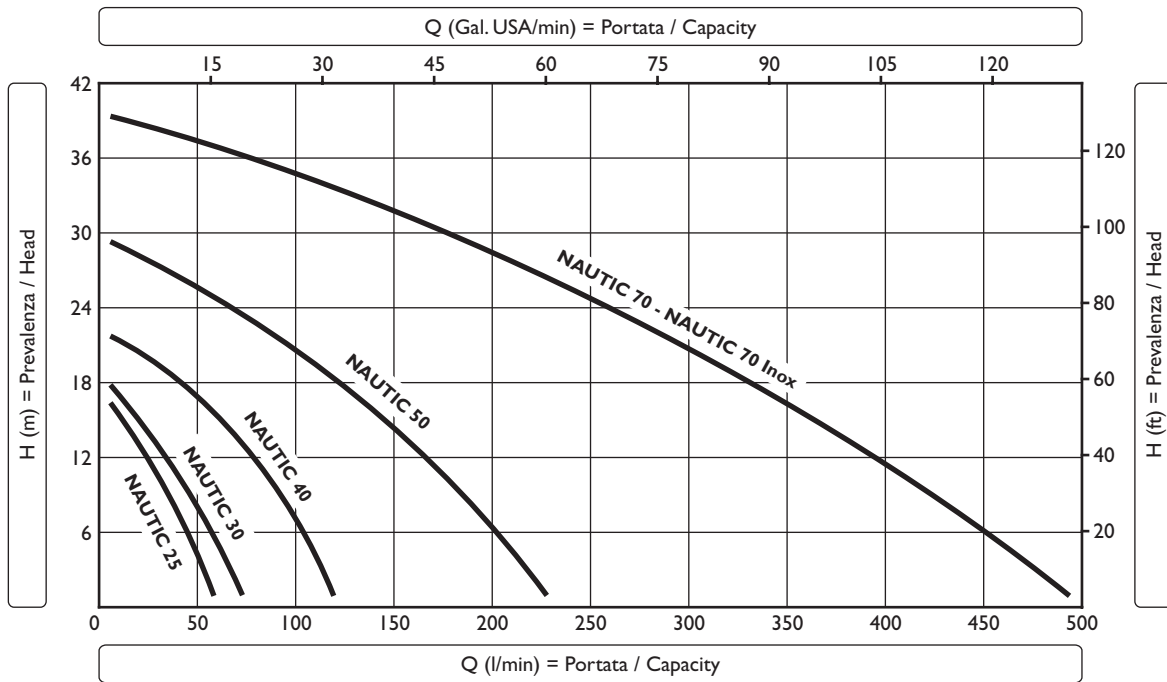

| Tipo Type | Codice Code | Materiale Material | Peso Weight | Giri/min Rpm | H (m) = Prevalenza / Head - Q (l/min) = Portata / Capacity | | | | | | | | | | |
|-----------------------|-------------|--------------------|-------------|--------------|--|-----|-----|-----|-----|-----|-----|-----|----|---|---|
| | | | | | 0 | 5 | 10 | 12 | 15 | 18 | 22 | 30 | 40 | H | |
| NAUTIC 25 | 51132500 | Bronzo/Bronze | 4,1 kg | 2800 | 60 | 50 | 25 | 15 | 8 | 0 | | | | | Q |
| NAUTIC 30 | 51133000 | Bronzo/Bronze | 5,7 kg | 1400 | 75 | 60 | 40 | 30 | 15 | 0 | | | | | |
| NAUTIC 40 | 51134000 | Bronzo/Bronze | 7,4 kg | 1400 | 120 | 110 | 85 | 80 | 55 | 45 | 0 | | | | |
| NAUTIC 50 | 51135000 | Bronzo/Bronze | 12,8 kg | 1400 | 230 | 210 | 175 | 155 | 140 | 125 | 85 | 0 | | | |
| NAUTIC 70 | 51137000 | Bronzo/Bronze | 25,3 kg | 1400 | 500 | 460 | 415 | 400 | 370 | 330 | 280 | 165 | 0 | | |
| NAUTIC 70 Inox | 60137000 | Inox AISI 316 | 25,3 kg | 1400 | 500 | 460 | 415 | 400 | 370 | 330 | 280 | 165 | 0 | | |

NAUTIC 25-30-40-50

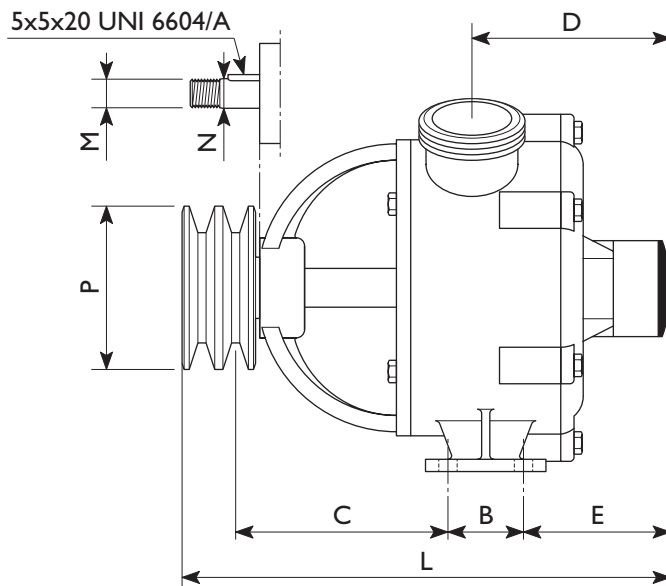
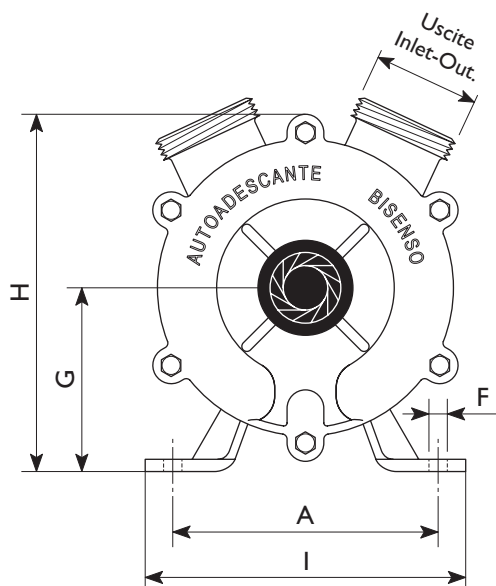
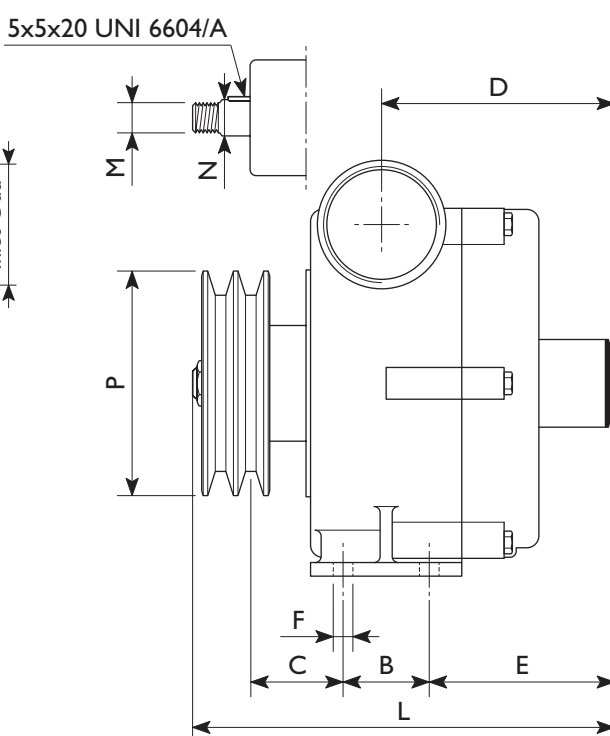
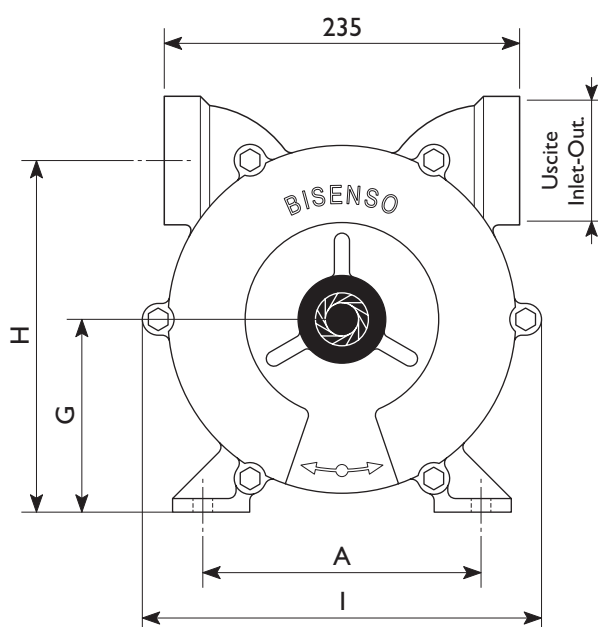
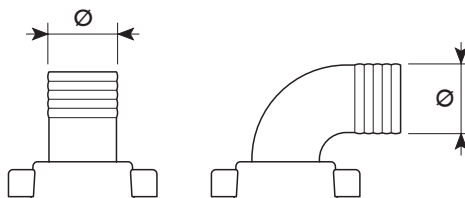
NAUTIC 70
NAUTIC 70 InoxRaccordi
Pipe fittings

| Tipo Type | Uscite Inlet-Outlet | Raccordi Pipe fittings | Dimensioni (mm) / Dimensions (mm) | | | | | | | | | | | | |
|----------------|------------------------|---------------------------|-----------------------------------|----|-----|-----|-----|-------|-----|-----|-----|-----|---------|-------|---------|
| | | | A | B | C | D | E | F | G | H | I | L | M | N | P |
| NAUTIC 25 | BSP-M 1" | Ø25 | 119,5 | 25 | 80 | 80 | 68 | Ø6,75 | 63 | 116 | 140 | 195 | M14x1,5 | Ø14,5 | Ø70x1A |
| NAUTIC 30 | BSP-M 1"1/4 | Ø30 - Ø35 | 130 | 28 | 103 | 85 | 70 | Ø9 | 90 | 175 | 157 | 218 | M14x1,5 | Ø14,5 | Ø70x1A |
| NAUTIC 40 | BSP-M 1"1/2 | Ø40 - Ø45 | 130 | 37 | 108 | 105 | 76 | Ø9 | 90 | 175 | 157 | 245 | M14x1,5 | Ø14,5 | Ø80x2A |
| NAUTIC 50 | BSP-M 2" | Ø50 | 160 | 40 | 138 | 125 | 91 | Ø11 | 120 | 225 | 188 | 298 | M16 | Ø19 | Ø80x2A |
| NAUTIC 70 | BSP-F 2"1/2 | n.d. | 184 | 57 | 64 | 144 | 110 | Ø13 | 128 | 231 | 260 | 269 | M18x1,5 | Ø24 | Ø149x2B |
| NAUTIC 70 Inox | BSP-M 2"1/2 * | n.d. | 184 | 57 | 64 | 144 | 110 | Ø13 | 128 | 231 | 260 | 269 | M18x1,5 | Ø24 | Ø149x2B |

ISO R 52-253

* = Uscite standard BSP (Gas), altre uscite disponibili p.20 / Standard inlet-outlet BSP (Gas), different inlet-outlet are available see p.20
n.d. = Raccordi non disponibili / Pipe fittings not available

POMPE NAUTIC CON FRIZIONE MANUALE

NAUTIC PUMP TYPE WITH HAND CLUTCH



NAUTIC 30-40-50 F



NAUTIC 70 F

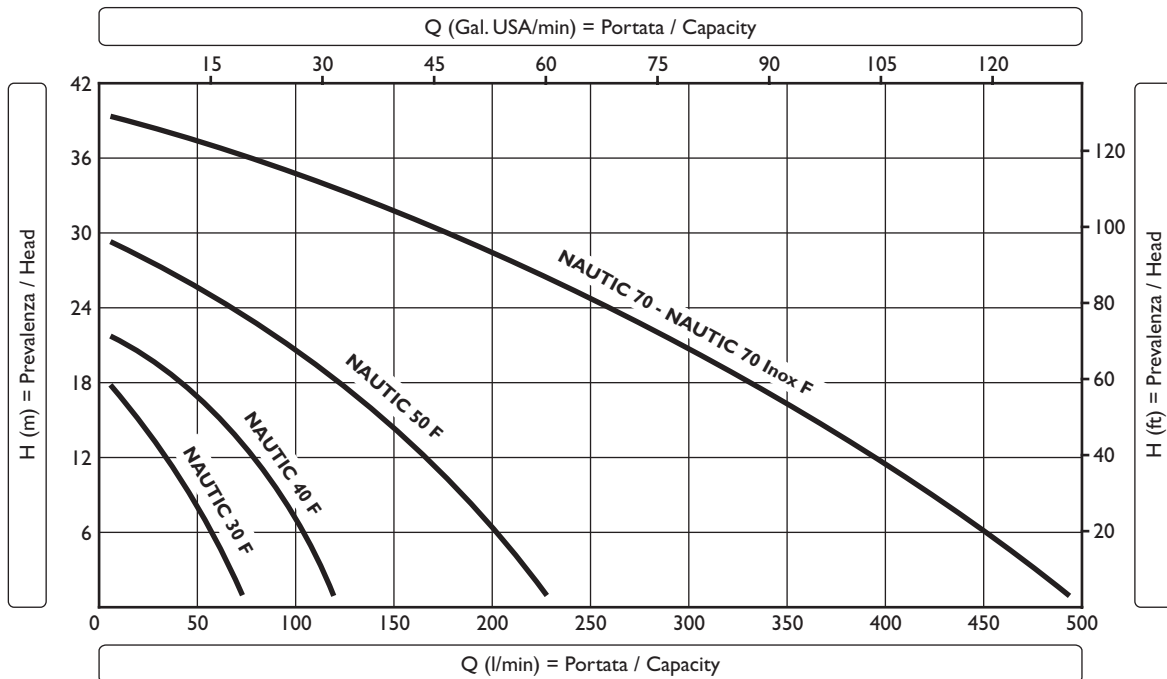

| Tipo Type | Codice Code | Materiale Material | Peso Weight | Giri/min Rpm | H (m) = Prevalenza / Head - Q (l/min) = Portata / Capacity | | | | | | | | | | | |
|-------------------------|----------------|-----------------------|----------------|-----------------|--|-----|-----|-----|-----|-----|-----|-----|----|---|--|--|
| | | | | | 0 | 5 | 10 | 12 | 15 | 18 | 22 | 30 | 40 | H | | |
| NAUTIC 30 F | 51143000 | Bronzo/Bronze | 8,8 kg | 1400 | 75 | 60 | 40 | 30 | 15 | 0 | | | | | | |
| NAUTIC 40 F | 51144000 | Bronzo/Bronze | 10,5 kg | 1400 | 120 | 110 | 85 | 80 | 55 | 45 | 0 | | | | | |
| NAUTIC 50 F | 51145000 | Bronzo/Bronze | 15,6 kg | 1400 | 230 | 210 | 175 | 155 | 140 | 125 | 85 | 0 | | | | |
| NAUTIC 70 F | 51147000 | Bronzo/Bronze | 28,9 kg | 1400 | 500 | 460 | 415 | 400 | 370 | 330 | 280 | 165 | 0 | | | |
| NAUTIC 70 Inox F | 60147000 | Inox AISI 316 | 28,9 kg | 1400 | 500 | 460 | 415 | 400 | 370 | 330 | 280 | 165 | 0 | | | |

NAUTIC 30-40-50 F

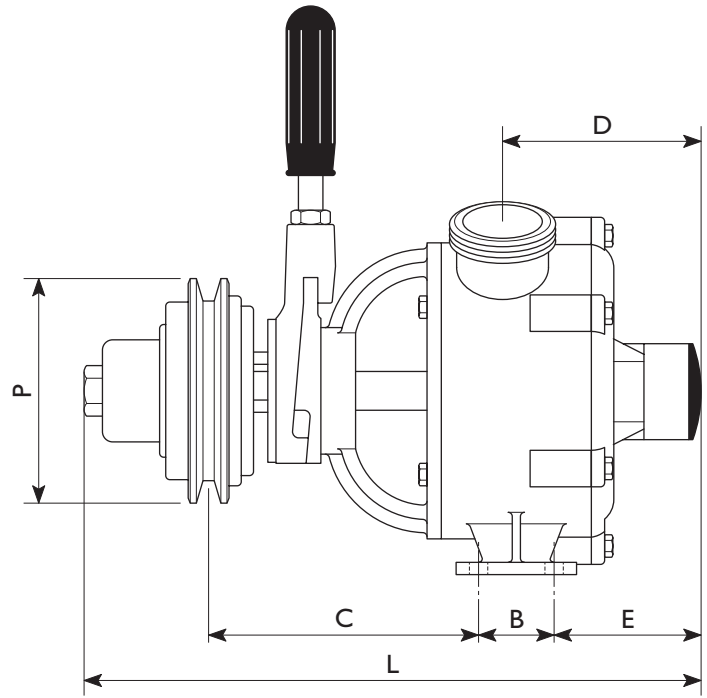
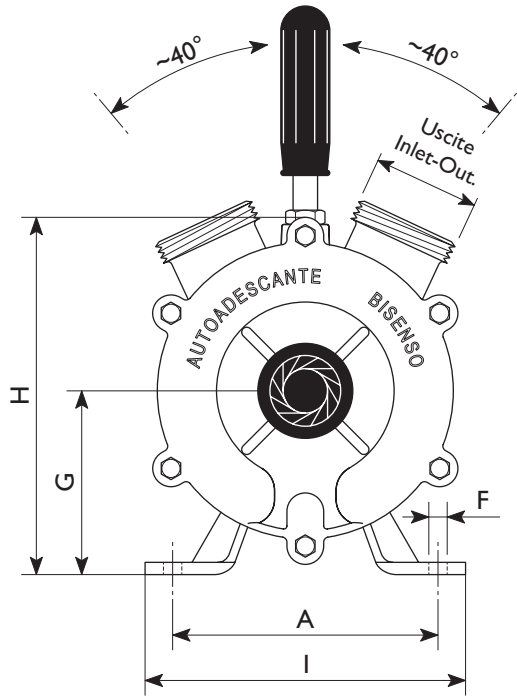

NAUTIC 70 F
NAUTIC 70 Inox F

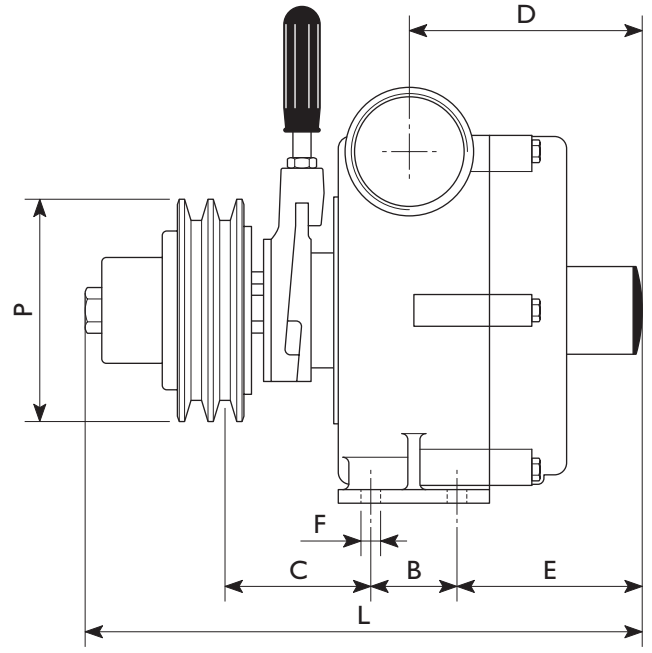
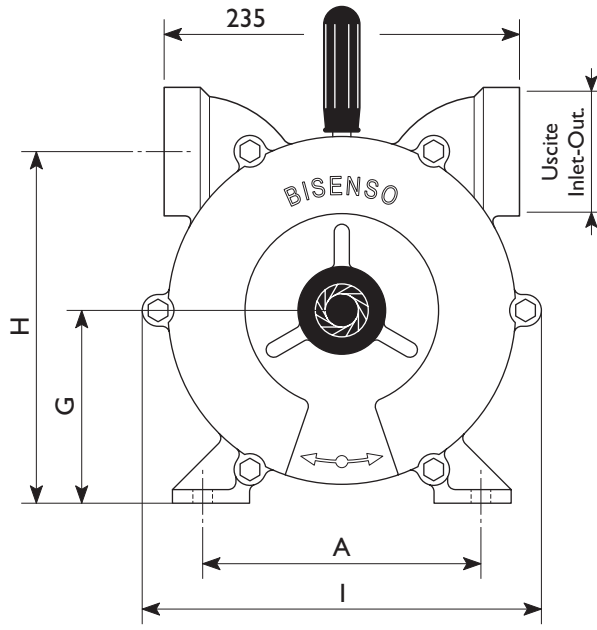

Raccordi
Pipe fittings

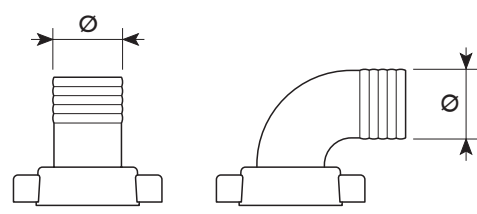

| Tipo Type | Uscite Inlet-Outlet | Raccordi Pipe fittings | Dimensioni (mm) / Dimensions (mm) | | | | | | | | | | |
|------------------|------------------------|---------------------------|-----------------------------------|----|-----|-----|-----|-----|-----|-----|-----|-----|---------|
| | | | A | B | C | D | E | F | G | H | I | L | P |
| NAUTIC 30 F | BSP-M 1"1/4 | Ø30 - Ø35 | 130 | 28 | 124 | 85 | 70 | Ø9 | 90 | 175 | 157 | 280 | Ø110x1A |
| NAUTIC 40 F | BSP-M 1"1/2 | Ø40 - Ø45 | 130 | 37 | 130 | 105 | 76 | Ø9 | 90 | 175 | 157 | 305 | Ø110x1A |
| NAUTIC 50 F | BSP-M 2" | Ø50 | 160 | 40 | 160 | 125 | 91 | Ø11 | 120 | 225 | 188 | 365 | Ø110x2A |
| NAUTIC 70 F | BSP-F 2"1/2 | n.d. | 184 | 57 | 97 | 144 | 110 | Ø13 | 128 | 231 | 260 | 355 | Ø147x2B |
| NAUTIC 70 Inox F | BSP-M 2"1/2 * | n.d. | 184 | 57 | 97 | 144 | 110 | Ø13 | 128 | 231 | 260 | 355 | Ø147x2B |

ISOR 52-253

* = Uscite standard BSP (Gas), altre uscite disponibili p.20 / Standard inlet-outlet BSP (Gas), different inlet-outlet are available see p.20
n.d. = Raccordi non disponibili / Pipe fittings not available

POMPE MID PER MOTORI IDRAULICI

MID PUMP TYPE FOR HYDRAULIC MOTORS

10



MID 40-50



MID MASTER 2''



MID 70 Inox

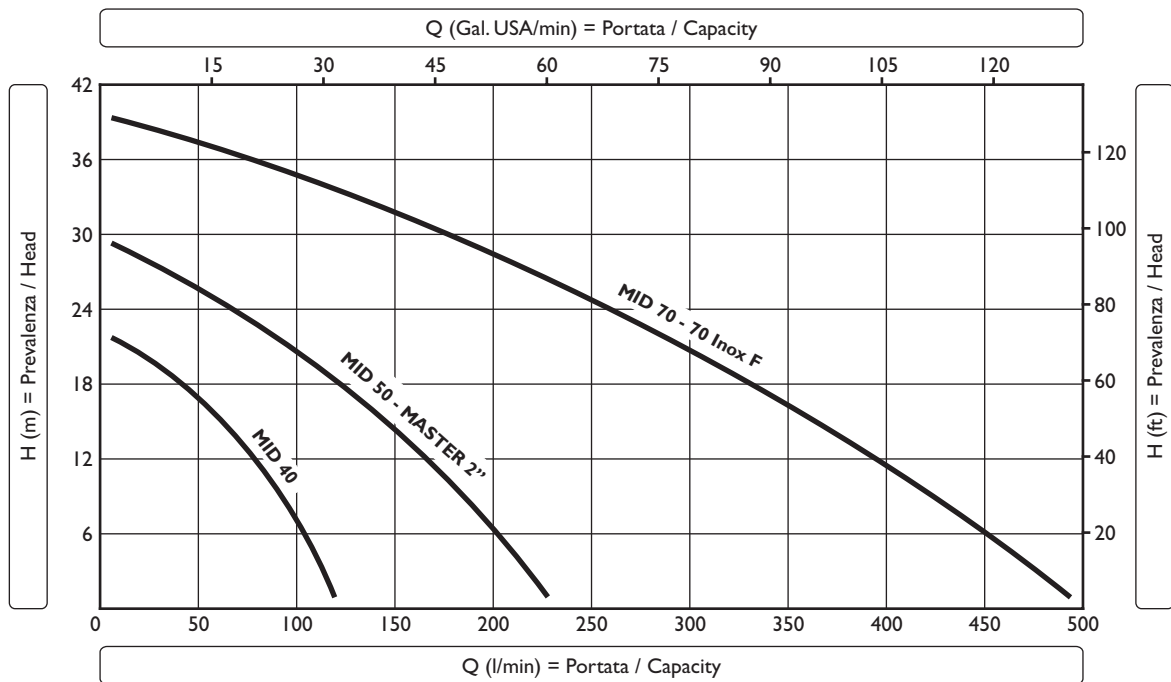

| Tipo Type | Codice Code | Materiale Material | Peso Weight | Giri/min Rpm | H (m) = Prevalenza / Head - Q (l/min) = Portata / Capacity | | | | | | | | | | |
|-----------------------|----------------|-----------------------|----------------|-----------------|--|-----|-----|-----|-----|-----|-----|-----|----|---|--|
| | | | | | 0 | 5 | 10 | 12 | 15 | 18 | 22 | 30 | 40 | H | |
| MID 40 | 51134036 | Bronzo/Bronze | 7,2 kg | 1400 | 120 | 110 | 85 | 80 | 55 | 45 | 0 | | | | |
| MID 50 | 51135036 | Bronzo/Bronze | 11,4 kg | 1400 | 230 | 210 | 175 | 155 | 140 | 125 | 85 | 0 | | | |
| MID 70 | 51137036 | Bronzo/Bronze | 25,5 kg | 1400 | 500 | 460 | 415 | 400 | 370 | 330 | 280 | 165 | 0 | | |
| MID MASTER 2'' | 60135039 | Inox AISI 316 | 11,3 kg | 1400 | 230 | 210 | 175 | 155 | 140 | 125 | 85 | 0 | | | |
| MID 70 Inox | 60137039 | Inox AISI 316 | 21,4 kg | 1400 | 500 | 460 | 415 | 400 | 370 | 330 | 280 | 165 | 0 | | |

MID 40-50-MASTER 2"

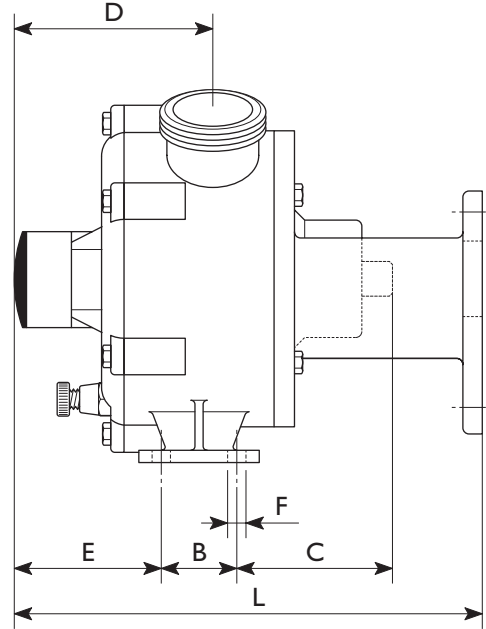
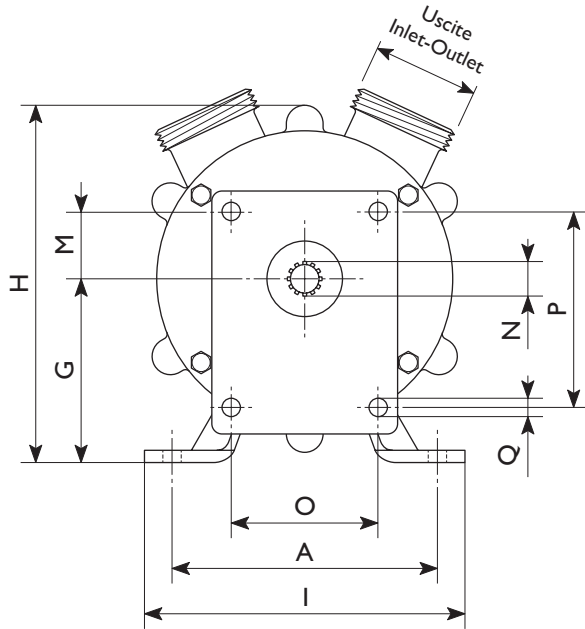

MID 70 - MID 70 Inox

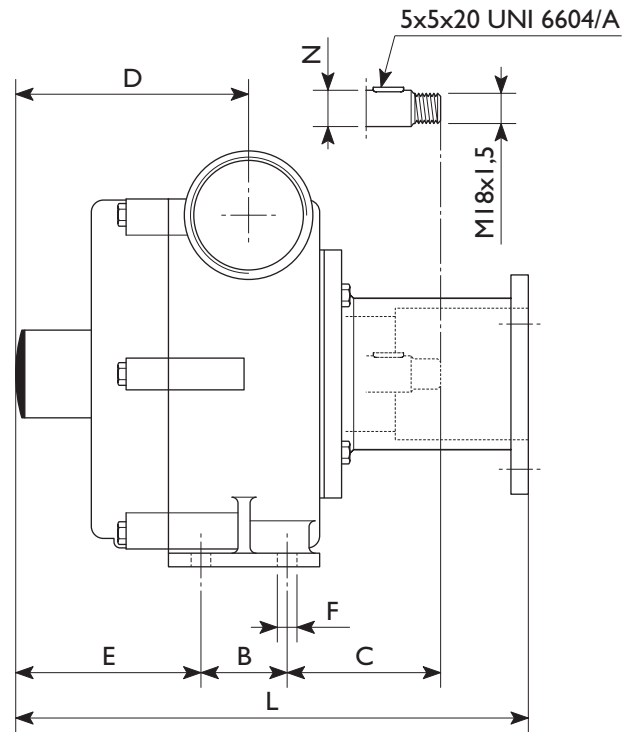
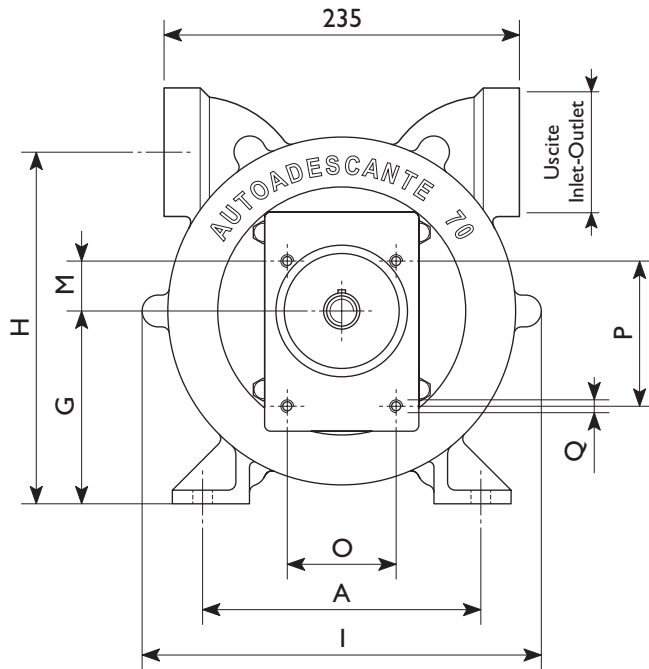

Raccordi
Pipe fittings

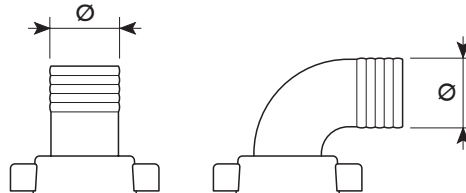

| Tipo Type | Uscite Inlet-Outlet | Raccordi Pipe fittings | Dimensioni (mm) / Dimensions (mm) | | | | | | | | | | | | | | |
|----------------------|------------------------|---------------------------|-----------------------------------|----|-----|-----|-----|-----|-----|-----|-----|-----|----|-------------|----|----|----|
| | | | A | B | C | D | E | F | G | H | I | L | M | N | O | P | Q |
| MID 40 | BSP-M 1"1/2 | Ø40 - Ø45 | 130 | 37 | 78 | 105 | 76 | Ø9 | 90 | 175 | 157 | 235 | 33 | Ø16,8 - z14 | 72 | 96 | Ø9 |
| MID 50 | BSP-M 2" | Ø50 | 160 | 40 | 84 | 125 | 91 | Ø11 | 120 | 225 | 188 | 265 | 33 | Ø19,8 - z17 | 72 | 96 | Ø9 |
| MID 70 | BSP-F 2"1/2 | n.d. | 184 | 57 | 102 | 144 | 110 | Ø13 | 128 | 231 | 260 | 330 | 33 | Ø24 | 72 | 96 | M8 |
| MID MASTER 2" | BSP-M 2" * | Ø50 ** | 160 | 40 | 85 | 125 | 91 | Ø11 | 120 | 225 | 188 | 270 | 33 | Ø19,8 - z17 | 72 | 96 | Ø9 |
| MID 70 Inox | BSP-M 2"1/2 * | n.d. | 184 | 57 | 102 | 144 | 110 | Ø13 | 128 | 231 | 260 | 330 | 33 | Ø24 | 72 | 96 | M8 |

* = Uscite standard BSP (Gas), altre uscite disponibili p.20 / Standard inlet-outlet BSP (Gas), different inlet-outlet are available see p.20

** = Raccordi in acciaio inox o nylon a richiesta / Stainless steel or nylon pipe fittings on request

n.d. = Raccordi non disponibili / Pipe fittings not available

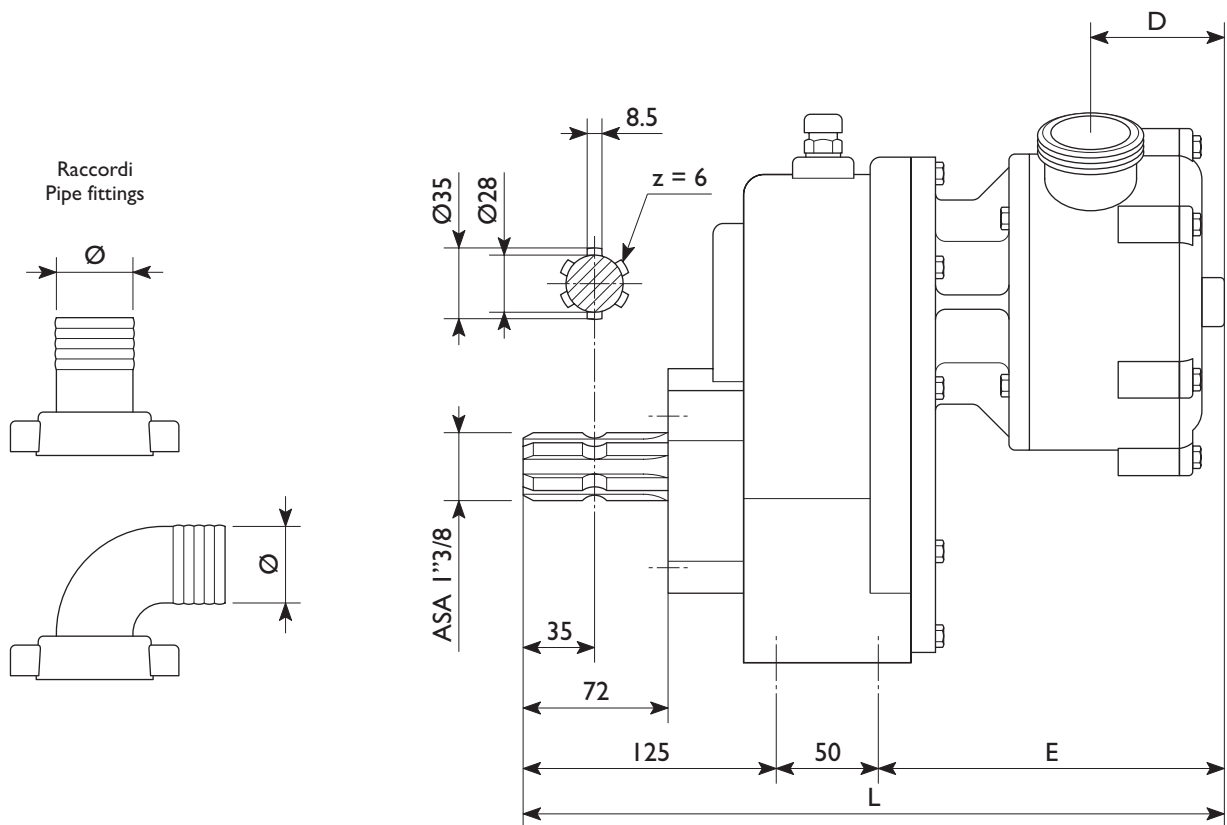
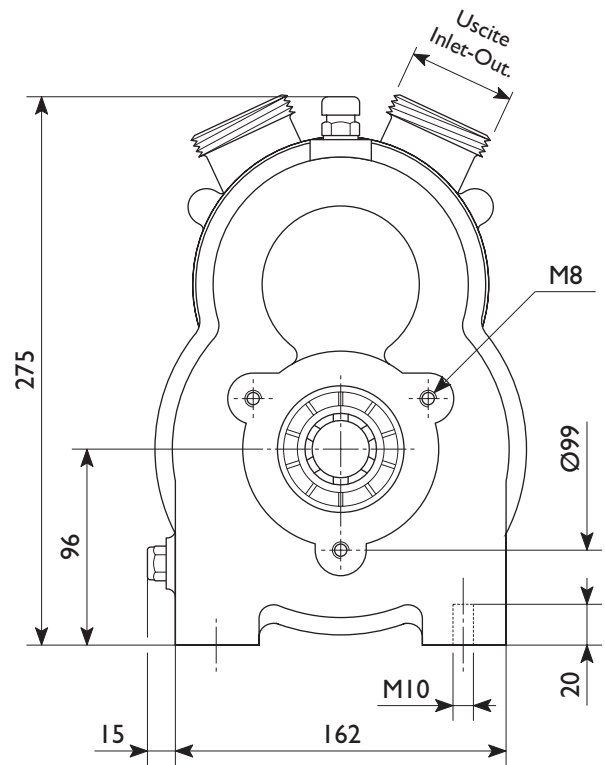
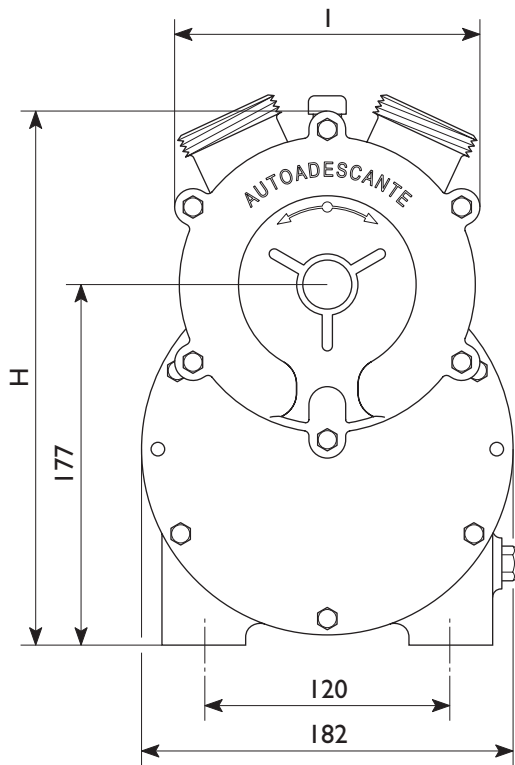

| Tipo Type | Uscite Inlet-Outlet | Raccordi Pipe fittings | Dimensioni (mm) / Dimensions (mm) | | | | |
|--------------------------|------------------------|---------------------------|-----------------------------------|-----|-----|-----|-----|
| | | | D | E | H | I | L |
| LALX 40 | BSP-M 1"1/2 | Ø40 - Ø45 | 67 | 171 | 86 | 150 | 346 |
| LALX 50 | BSP-M 2" | Ø50 | 90 | 203 | 103 | 185 | 378 |
| LALX SENIOR 1"1/2 | BSP-M 1"1/2 * | Ø40 ** | 76 | 181 | 86 | 167 | 356 |
| LALX MASTER 2" | BSP-F 2" * | Ø50 ** | 94 | 208 | 103 | 205 | 383 |

* = Uscite standard BSP (Gas), altre uscite disponibili p.20 / Standard inlet-outlet BSP (Gas), different inlet-outlet are available see p.20

** = Raccordi in acciaio inox o nylon a richiesta / Stainless steel or nylon pipe fittings on request

ELETTROPOMPE IN BRONZO

BRONZE ELECTRIC PUMPS

14



EP 20-25-30-40-50 CC

EPH 20-25 MF
EP 20-25-30-40-50 MF/TF



| | | | |
|----------|--|---|-------------|
| L | | 1.5m+PLUG | IP55 |
| I | | 6 m | IP55 |
| M | | Morsettiera Terminal board connection | IP55 |

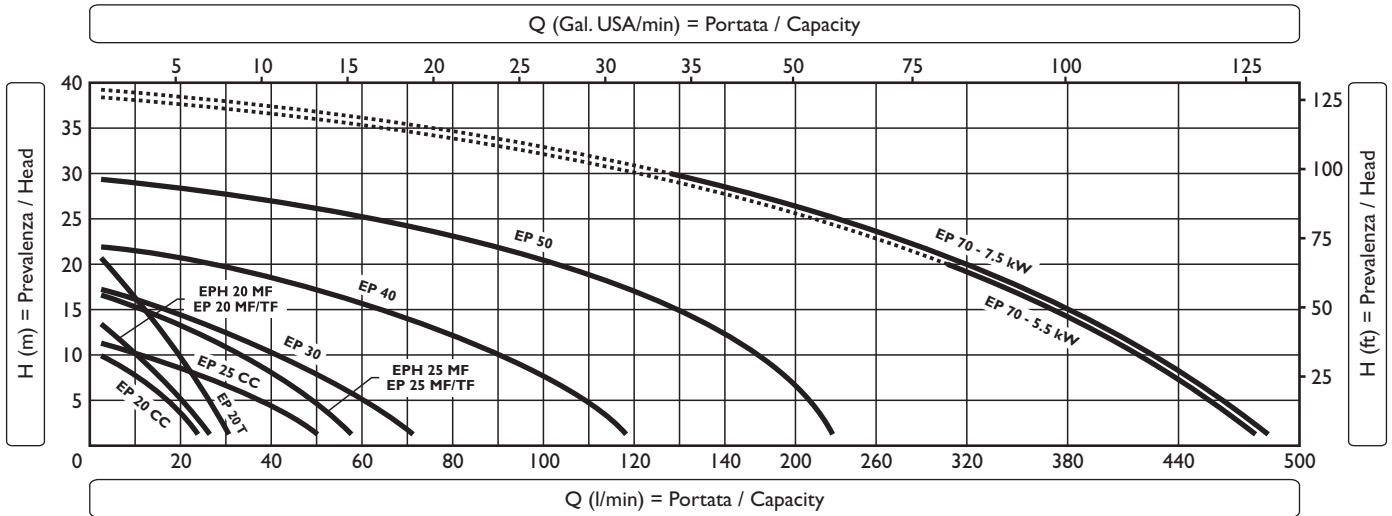

| Tipo Type | Codice Code | Peso Weight | Maniglia Handle | Motore * - Motor * | | | | Giri/min Rpm | H (m) = Prevalenza/Head - Q (l/min) = Portata/Capacity | | | | | | | | | | | | | | | |
|----------------|----------------|----------------|--------------------|--------------------|------|-----------|------|-----------------|--|-----|-----|-----|-----|-----|-----|-----|-----|---|--|--|--|--|--|--|
| | | | | Tipo / Type | Volt | HP | kW | | 0 | 5 | 10 | 12 | 15 | 18 | 22 | 30 | 40 | H | | | | | | |
| EPH 20 | 51202000H | 5,5 kg | ● | L | MF | 230V | 0,3 | 0,22 | 2800 | 29 | 20 | 10 | 6 | 0 | | | | | | | | | | |
| EPH 25 | 51202500H | 9,2 kg | ● | L | MF | 230V | 0,6 | 0,45 | 2800 | 60 | 50 | 25 | 15 | 8 | 0 | | | | | | | | | |
| EP 20 T | 51402000T | 5,7 kg | ● | M | CC | 12V / 26A | 0,45 | 0,33 | 3000 | 32 | 27 | 18 | 15 | 11 | 5 | 0 | | | | | | | | |
| | 51412000T | 5,6 kg | ● | M | CC | 24V / 14A | 0,45 | 0,33 | 3000 | 32 | 27 | 18 | 15 | 11 | 5 | 0 | | | | | | | | |
| EP 20 | 51402000 | 5,7 kg | ● | M | CC | 12V / 26A | 0,45 | 0,33 | 2000 | 25 | 18 | 0 | | | | | | | | | | | | |
| | 51412000 | 5,6 kg | ● | M | CC | 24V / 14A | 0,45 | 0,33 | 2000 | 25 | 18 | 0 | | | | | | | | | | | | |
| | 51202000 | 6,3 kg | ● | I | MF | 230V | 0,3 | 0,22 | 2800 | 29 | 20 | 10 | 6 | 0 | | | | | | | | | | |
| EP 20 | 51302000 | 6,3 kg | ● | I | | | | | | | | | | | | | | | | | | | | |
| | 51302001 | 5,9 kg | ● | M | TF | 230-400V | 0,35 | 0,26 | 2800 | 29 | 20 | 10 | 6 | 0 | | | | | | | | | | |
| | 51402500 | 9,2 kg | ● | M | CC | 12V / 38A | 0,6 | 0,45 | 2000 | 53 | 37 | 10 | 0 | | | | | | | | | | | |
| EP 25 | 51412500 | 9,3 kg | ● | M | CC | 24V / 22A | 0,6 | 0,45 | 2000 | 53 | 37 | 10 | 0 | | | | | | | | | | | |
| | 51202500 | 9,8 kg | X | I | MF | 230V | 0,6 | 0,45 | 2800 | 60 | 50 | 25 | 15 | 8 | 0 | | | | | | | | | |
| | 51302500 | 9,8 kg | X | I | | | | | | | | | | | | | | | | | | | | |
| | 51302501 | 8,9 kg | X | M | TF | 230-400V | 0,75 | 0,56 | 2800 | 60 | 50 | 25 | 15 | 8 | 0 | | | | | | | | | |
| EP 30 | 51413000 | 13,5 kg | ● | M | CC | 24V / 28A | 0,8 | 0,60 | 1400 | 75 | 60 | 40 | 30 | 15 | 0 | | | | | | | | | |
| | 51203000 | 13,2 kg | X | I | MF | 230V | 1 | 0,75 | 1400 | 75 | 60 | 40 | 30 | 15 | 0 | | | | | | | | | |
| | 51303000 | 13,2 kg | X | I | | | | | | | | | | | | | | | | | | | | |
| | 51303001 | 12,5 kg | X | M | TF | 230-400V | 1 | 0,75 | 1400 | 75 | 60 | 40 | 30 | 15 | 0 | | | | | | | | | |
| EP 40 | 51414000 | 19,8 kg | ● | M | CC | 24V / 45A | 1,5 | 1,12 | 1400 | 120 | 110 | 85 | 80 | 55 | 45 | 0 | | | | | | | | |
| | 51204000 | 16,2 kg | X | I | MF | 230V | 1 | 0,75 | 1400 | 120 | 110 | 85 | 80 | 55 | 45 | 0 | | | | | | | | |
| | 51204100 | 17,7 kg | X | I | MF | 230V | 1,5 | 1,12 | 1400 | 120 | 110 | 85 | 80 | 55 | 45 | 0 | | | | | | | | |
| | 51304000 | 15,7 kg | X | I | TF | 230-400V | 1 | 0,75 | 1400 | 120 | 110 | 85 | 80 | 55 | 45 | 0 | | | | | | | | |
| | 51304100 | 17,7 kg | X | I | | | | | | | | | | | | | | | | | | | | |
| EP 50 | 51304101 | 17,0 kg | X | M | TF | 230-400V | 1,5 | 1,12 | 1400 | 120 | 110 | 85 | 80 | 55 | 45 | 0 | | | | | | | | |
| | 51415000 | 35,5 kg | n.d. | M | CC | 24V / 95A | 2 | 1,5 | 1400 | 230 | 210 | 175 | 155 | 140 | 125 | 85 | 0 | | | | | | | |
| | 51205100 | 27,5 kg | n.d. | I | MF | 230V | 2,5 | 1,86 | 1400 | 230 | 210 | 175 | 155 | 140 | 125 | 85 | 0 | | | | | | | |
| | 51305100 | 26,5 kg | n.d. | I | | | | | | | | | | | | | | | | | | | | |
| EP 70 | 51305101 | 26,0 kg | n.d. | M | TF | 230-400V | 2,5 | 1,86 | 1400 | 230 | 210 | 175 | 155 | 140 | 125 | 85 | 0 | | | | | | | |
| | 51377001 | 75,0 kg | n.d. | M | TF | 230-400V | 7,5 | 5,5 | 1400 | 500 | 460 | 415 | 400 | 370 | 330 | 280 | 165 | 0 | | | | | | |
| EP 70 | 51377101 | 87,0 kg | n.d. | M | TF | 230-400V | 10 | 7,5 | 1400 | 500 | 460 | 415 | 400 | 370 | 330 | 280 | 165 | 0 | | | | | | |

● = Pompe con maniglia inclusa - Pumps with handle included / X = disponibile a richiesta - available on request / n.d. = non disponibile - not available
* MF = Monofase / Single Phase - TF = Trifase / Three Phase - CC = Corrente Continua / Direct Current

EPH 20-25
EP 20-25-30-40-50

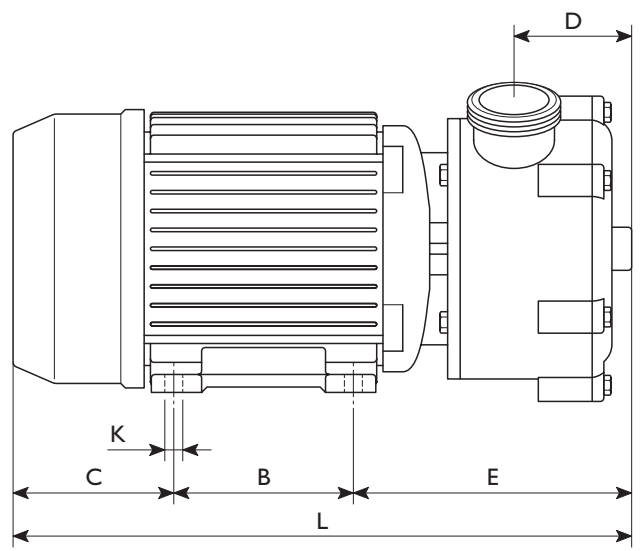
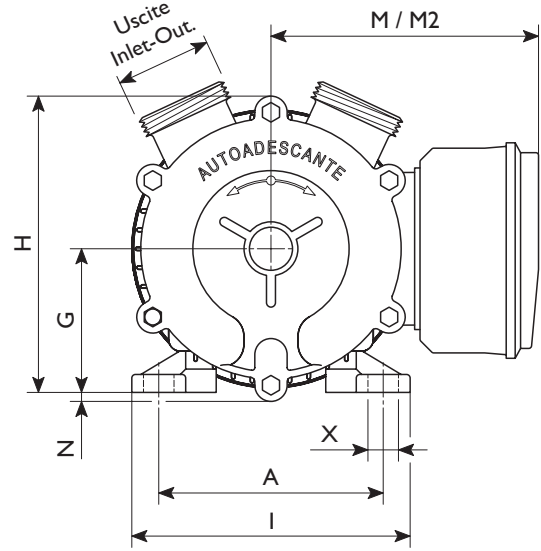

EP 70

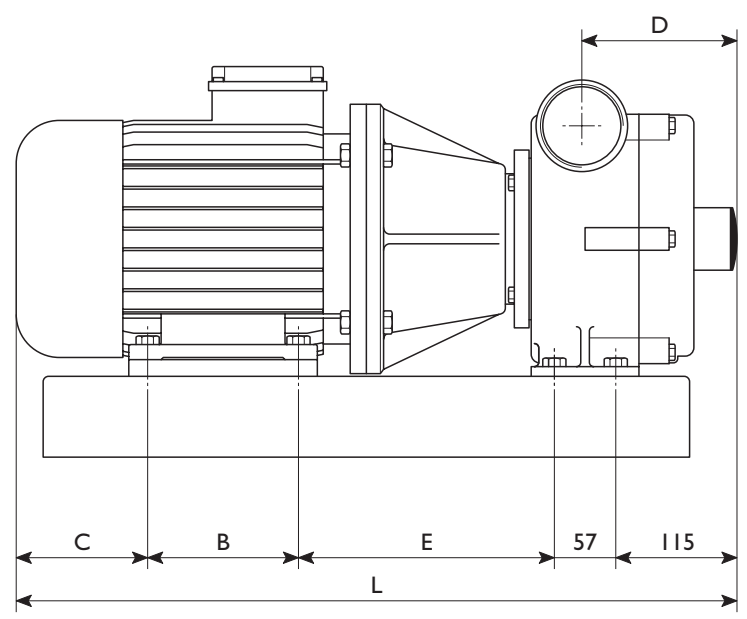
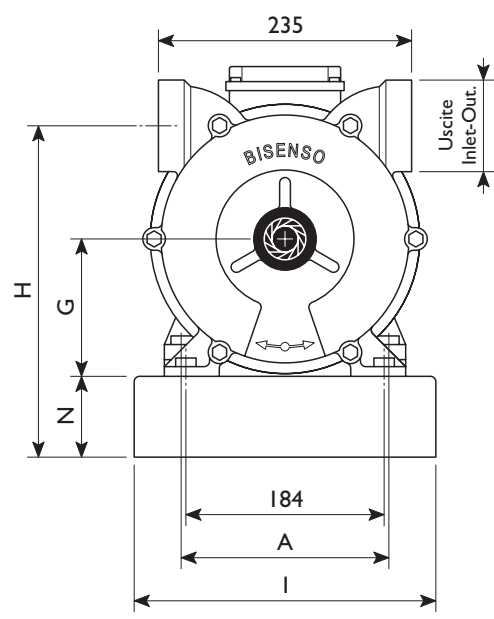

Raccordi
Pipe fittings

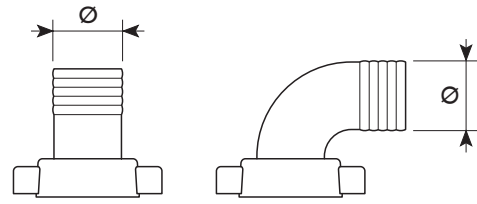

| Tipo Type | Uscite Inlet-Outlet | Raccordi Pipe fittings | Motore Motor | Dimensioni (mm) / Dimensions (mm) | | | | | | | | | | | | | |
|--------------|------------------------|---------------------------|-----------------|-----------------------------------|-----|-----|-----|-----|-----|-----|-----|----|-----|-----|-----|----|------|
| | | | | A | B | C | D | E | G | H | I | K | L | M* | M2* | N | X |
| EPH 20 | BSP-M 3/4" | Ø20 | MF | 90 | 70 | 70 | 35 | 110 | 56 | 100 | 110 | 7 | 250 | 115 | 105 | - | 10 |
| EPH 25 | BSP-M 1" | Ø25 | MF | 112 | 90 | 78 | 40 | 127 | 71 | 124 | 136 | 7 | 295 | - | 105 | - | 12 |
| EP 20 | BSP-M 3/4" | Ø20 | CC | 100 | 80 | 100 | 35 | 115 | 63 | 106 | 120 | 7 | 295 | - | 105 | - | 12 |
| | | | MF/TF | 90 | 70 | 70 | 35 | 110 | 56 | 100 | 110 | 7 | 250 | 135 | 105 | - | 10 |
| EP 25 | BSP-M 1" | Ø25 | CC | 112 | 90 | 103 | 40 | 127 | 71 | 124 | 130 | 8 | 320 | - | 110 | - | 12 |
| | | | MF/TF | 112 | 90 | 88 | 40 | 127 | 71 | 124 | 136 | 8 | 305 | 145 | 110 | - | 12 |
| EP 30 | BSP-M 1" 1/4 | Ø30 - Ø35 | CC | 125 | 100 | 135 | 50 | 140 | 80 | 165 | 160 | 8 | 375 | - | 125 | 5 | 16 |
| | | | MF/TF | 125 | 100 | 90 | 50 | 140 | 80 | 165 | 155 | 10 | 330 | 155 | 125 | 5 | 17.5 |
| EP 40 | BSP-M 1" 1/2 | Ø40 - Ø45 | CC | 140 | 125 | 185 | 67 | 180 | 90 | 175 | 175 | 10 | 490 | - | 130 | - | 17.5 |
| | | | MF/TF | 125 | 100 | 90 | 67 | 162 | 80 | 165 | 155 | 10 | 352 | 155 | 125 | 5 | 17.5 |
| EP 50 | BSP-M 2" | Ø50 | CC | 140 | 125 | 137 | 90 | 180 | 90 | 194 | 175 | 10 | 442 | - | - | 14 | 17.5 |
| | | | MF/TF | 140 | 125 | 100 | 90 | 210 | 90 | 194 | 175 | 10 | 435 | 160 | 130 | 14 | 17.5 |
| EP 70 | BSP-F 2" 1/2 | n.d. | TF 5.5 kW | 190 | 140 | 148 | 144 | 245 | 128 | 306 | 280 | 11 | 705 | - | - | 75 | 18 |
| | | | TF 7.5 kW | 216 | 178 | 155 | 144 | 280 | 156 | 334 | 280 | 11 | 785 | - | - | 75 | 18 |

n.d. = Raccordi non disponibili / Pipe fittings not available

M* = interruttore/invertitore-portacondensatore / on-off reverse switch-capacitor box - M2* = morsettiera / terminal board connection

ELETTROPOMPE IN ACCIAIO INOX AISI 316

STAINLESS STEEL AISI 316 ELECTRIC PUMPS

16



| | | | |
|----------|--|--|-------------|
| L | | 1.5m+PLUG | IP55 |
| I | | 6 m | IP55 |
| M | | Morsettiera Terminal board connection | IP55 |

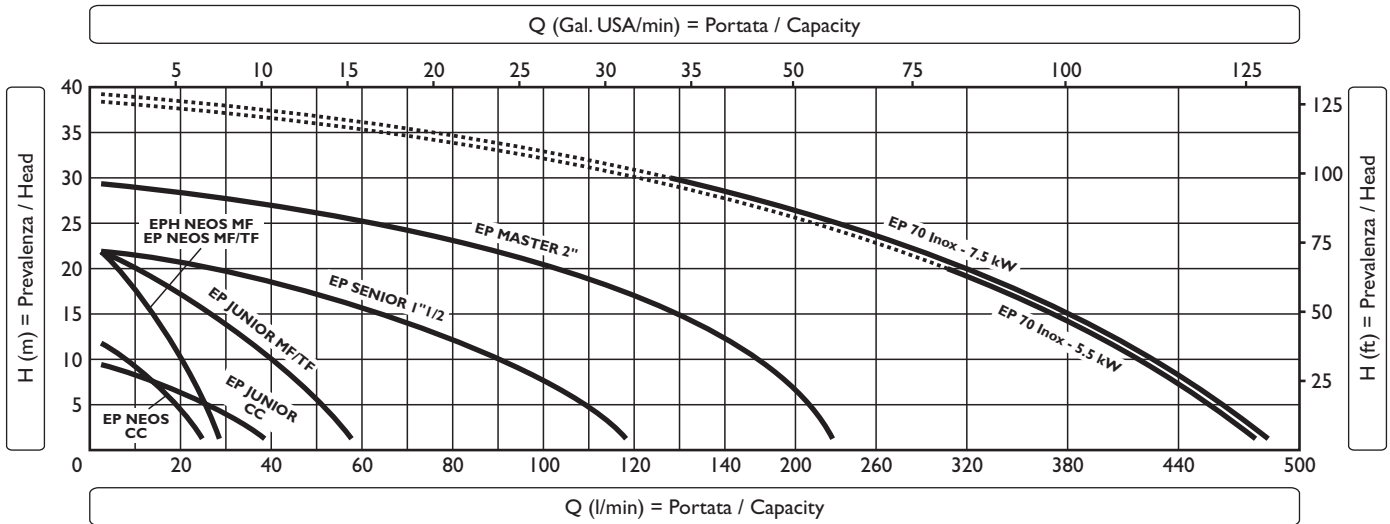

| Tipo Type | Codice Code | Peso Weight | Maniglia Handle | Motore * - Motor * | | | | Giri/min Rpm | H (m)=Prevalenza/Head - Q (l/min)=Portata/Capacity | | | | | | | | |
|------------------------|----------------|----------------|--------------------|--------------------|------|-----------|------|-----------------|--|-----|-----|-----|-----|-----|-----|-----|---|
| | | | | Tipo / Type | Volt | HP | kW | | 0 | 5 | 10 | 12 | 20 | 22 | 30 | 40 | H |
| EPH NEOS 3/4" | 60200548H | 4,9 kg | X | L | MF | 230V | 0,3 | 0,22 | 2800 | 29 | 23 | 17 | 14 | 10 | 0 | | |
| EP NEOS 3/4" T | 60400549T | 4,7 kg | ● | M | CC | 12V / 26A | 0,45 | 0,33 | 3000 | 36 | 30 | 20 | 17 | 3 | 0 | | |
| | 60410549T | 4,7 kg | ● | M | CC | 24V / 14A | 0,45 | 0,33 | 3000 | 36 | 30 | 20 | 17 | 3 | 0 | | |
| EP NEOS 3/4" | 60400549 | 4,7 kg | ● | M | CC | 12V / 26A | 0,45 | 0,33 | 2000 | 25 | 18 | 5 | 0 | | | | |
| | 60410549 | 4,7 kg | ● | M | CC | 24V / 14A | 0,45 | 0,33 | 2000 | 25 | 18 | 5 | 0 | | | | |
| | 60200548 | 5,1 kg | X | I | MF | 230V | 0,3 | 0,22 | 2800 | 29 | 23 | 17 | 14 | 10 | 0 | | |
| | 60300548 | 5,1 kg | X | I | TF | 230-400V | 0,35 | 0,26 | 2800 | 29 | 23 | 17 | 14 | 10 | 0 | | |
| 60300550 | 4,7 kg | X | M | TF | | | | | | | | | | | | | |
| EP JUNIOR 1 1/4 | 60401000 | 9,1 kg | ● | M | CC | 12V / 32A | 0,5 | 0,37 | 2000 | 43 | 25 | 0 | | | | | |
| | 60411000 | 9,3 kg | ● | M | CC | 24V / 20A | 0,5 | 0,37 | 2000 | 43 | 25 | 0 | | | | | |
| | 60201000 | 9,5 kg | X | I | MF | 230V | 0,6 | 0,45 | 2800 | 58 | 47 | 34 | 19 | 5 | 0 | | |
| | 60301000 | 9,6 kg | X | I | TF | 230-400V | 0,75 | 0,56 | 2800 | 58 | 47 | 34 | 19 | 5 | 0 | | |
| 60301001 | 8,7 kg | X | M | | | | | | | | | | | | | | |
| EP SENIOR 1 1/2 | 60414000 | 19,9 kg | ● | M | CC | 24V / 45A | 1,5 | 1,12 | 1400 | 120 | 110 | 85 | 55 | 30 | 0 | | |
| | 60204000 | 15,9 kg | X | I | MF | 230V | 1 | 0,75 | 1400 | 120 | 110 | 85 | 55 | 30 | 0 | | |
| | 60204100 | 17,5 kg | X | I | MF | 230V | 1,5 | 1,12 | 1400 | 120 | 110 | 85 | 55 | 30 | 0 | | |
| | 60304000 | 15,6 kg | X | I | TF | 230-400V | 1 | 0,75 | 1400 | 120 | 110 | 85 | 55 | 30 | 0 | | |
| | 60304100 | 17,6 kg | X | I | TF | 230-400V | 1,5 | 1,12 | 1400 | 120 | 110 | 85 | 55 | 30 | 0 | | |
| 60304101 | 16,9 kg | X | M | | | | | | | | | | | | | | |
| EP MASTER 2" | 60415000 | 35,5 kg | n.d. | M | CC | 24V / 95A | 2 | 1,5 | 1400 | 230 | 210 | 175 | 140 | 90 | 85 | 0 | |
| | 60205100 | 27,5 kg | n.d. | I | MF | 230V | 2,5 | 1,86 | 1400 | 230 | 210 | 175 | 140 | 90 | 85 | 0 | |
| | 60305100 | 26,5 kg | n.d. | I | TF | 230-400V | 2,5 | 1,86 | 1400 | 230 | 210 | 175 | 140 | 90 | 85 | 0 | |
| | 60305101 | 26,0 kg | n.d. | M | TF | | | | | | | | | | | | |
| EP 70 Inox | 60377081 | 75,0 kg | n.d. | M | TF | 230-400V | 7,5 | 5,5 | 1400 | 500 | 460 | 415 | 370 | 295 | 280 | 165 | 0 |
| | 60377181 | 87,0 kg | n.d. | M | TF | 230-400V | 10 | 7,5 | 1400 | 500 | 460 | 415 | 370 | 295 | 280 | 165 | 0 |

● = Pompe con maniglia inclusa - Pumps with handle included / X = disponibile a richiesta - available on request / n.d. = non disponibile - not available
 * MF = Monofase / Single Phase - TF = Trifase / Three Phase - CC = Corrente Continua / Direct Current

**EPH NEOS 3/4"
EP NEOS 3/4"**

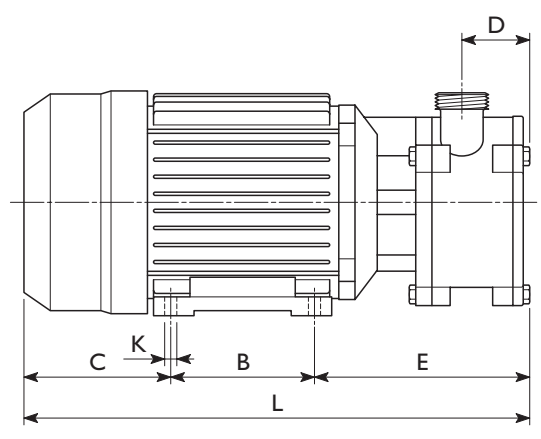
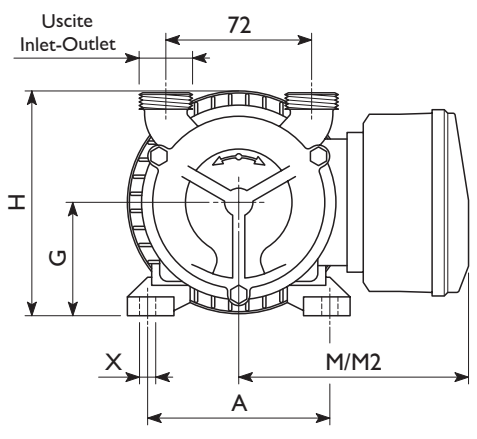

**EP JUNIOR 1"1/4
EP SENIOR 1"1/2
EP MASTER 2"**

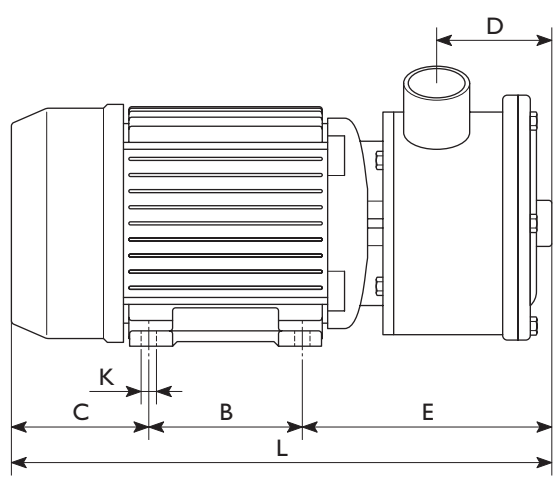
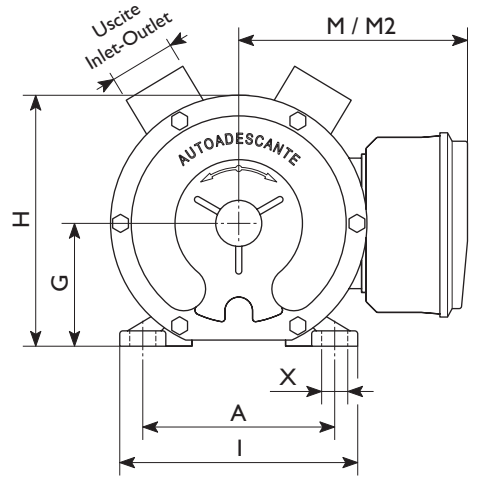

EP 70 Inox

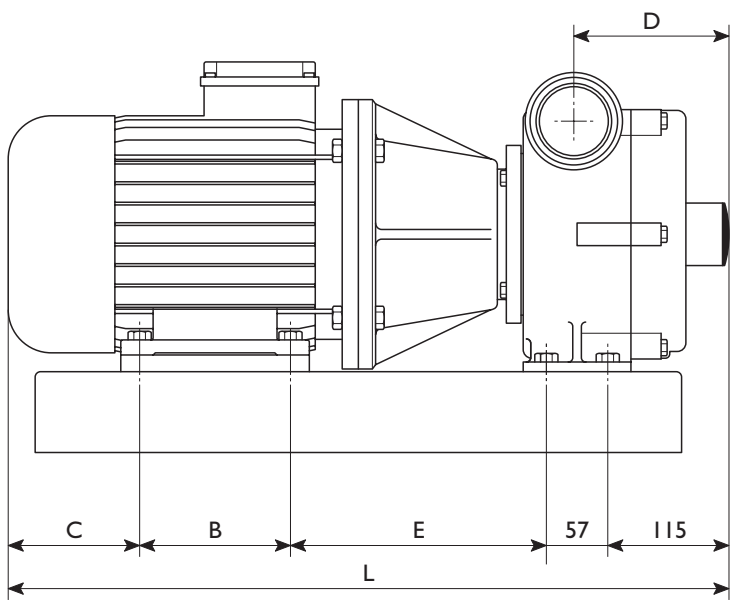
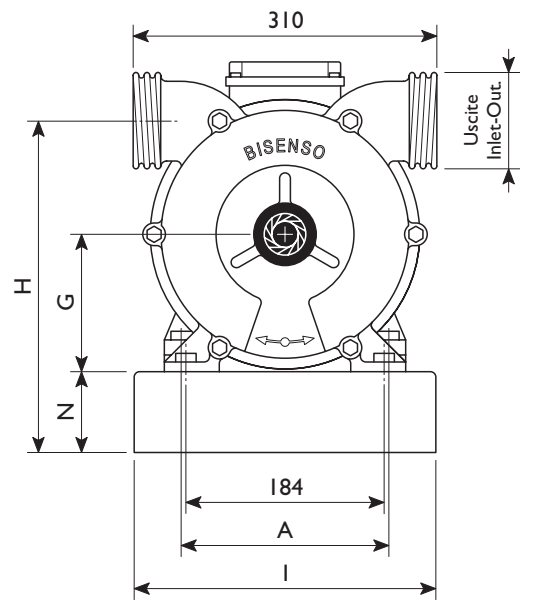

| Tipo Type | Uscite Inlet-Outlet | Raccordi Pipe fittings | Motore Motor | Dimensioni (mm) / Dimensions (mm) | | | | | | | | | | | | |
|------------------------|------------------------|---------------------------|-----------------|-----------------------------------|-----|-----|-----|-----|-----|-----|-----|-----|-----|-------|--------|------|
| | | | | A | B | C | D | E | G | H | I | K | L | M *** | M2 *** | X |
| EPH NEOS 3/4" | BSP-M 3/4" * | Ø20 ** | MF | 90 | 71 | 73 | 34 | 107 | 56 | 113 | - | 5.5 | 251 | 110 | - | 8 |
| | | | CC | 100 | 80 | 100 | 34 | 115 | 71 | 123 | - | 7 | 295 | - | 110 | 12 |
| EP NEOS 3/4" | BSP-M 3/4" * | Ø20 ** | MF/TF | 90 | 71 | 73 | 34 | 107 | 56 | 113 | - | 5.5 | 251 | 135 | 100 | 8 |
| | | | CC | 112 | 90 | 102 | 50 | 168 | 71 | 137 | 136 | 8 | 360 | - | 110 | 12 |
| EP JUNIOR 1"1/4 | BSP-M 1"1/4 * | Ø30 ** | MF/TF | 112 | 90 | 78 | 50 | 168 | 71 | 137 | 136 | 8 | 336 | 145 | 110 | 12 |
| | | | CC | 140 | 125 | 185 | 76 | 190 | 90 | 165 | 175 | 10 | 500 | - | 130 | 17.5 |
| EP SENIOR 1"1/2 | BSP-M 1"1/2 * | Ø40 ** | MF/TF | 125 | 100 | 90 | 76 | 170 | 80 | 165 | 155 | 10 | 360 | 155 | 125 | 17.5 |
| | | | CC | 140 | 125 | 137 | 94 | 185 | 90 | 193 | 175 | 10 | 447 | - | - | 17.5 |
| EP MASTER 2" | BSP-M 2" * | Ø50 ** | MF/TF | 140 | 125 | 100 | 94 | 215 | 90 | 193 | 175 | 10 | 440 | 160 | 130 | 17.5 |
| | | | TF 5.5 kW | 190 | 140 | 148 | 144 | 245 | 128 | 306 | 280 | 11 | 705 | - | - | 18 |
| EP 70 Inox | DIN 65 * | n.d. | TF 7.5 kW | 216 | 178 | 155 | 144 | 280 | 156 | 334 | 280 | 11 | 785 | - | - | 18 |

* = Uscite standard, altre uscite disponibili p.20 / Standard inlet-outlet, different inlet-outlet are available see p.20
 ** = Raccordi in acciaio inox o nylon a richiesta / Stainless steel or nylon pipe fittings on request
 M *** = interruttore/invertitore-portacondensatore / on-off reverse switch-capacitor box - M2 *** = morsettiera / terminal board connection
 n.d. = Raccordi non disponibili / Pipe fittings not available

GRUPPI ANTIDEFAGRANTI SENZA IMPIANTO ELETTRICO EXPLOSION PROOF GROUPS WITHOUT CONTROL PANELS



GRADPE NAUTIC



GRADPE SPECIAL

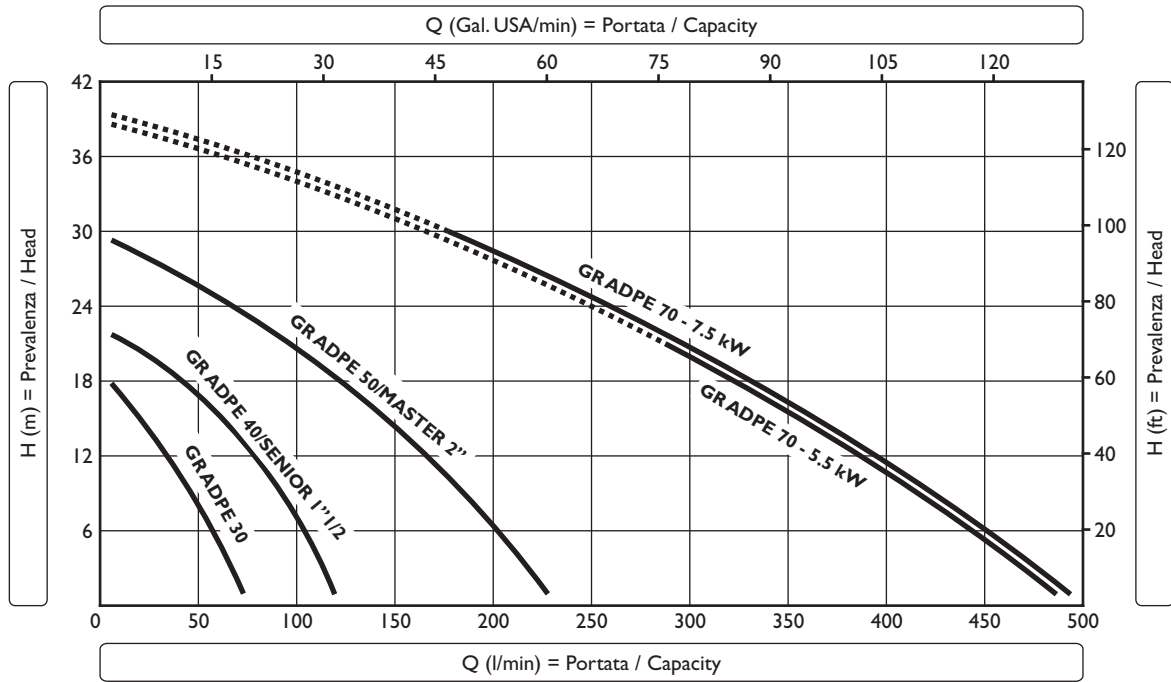

| Tipo Type | Codice / Code | | Peso Weight | Motore / Motor ** | | | | Giri/min Rpm | H (m) = Prevalenza / Head Q (l/min) = Portata / Capacity | | | | | | | |
|---|--------------------|---------------------------|----------------|-------------------|---------|-----|------|-----------------|---|-----|-----|-----|-----|-----|----|---|
| | su base on base | su carrello on trolley | | Tipo Type | Volt | HP | kW | | 0 | 5 | 10 | 18 | 22 | 30 | 40 | H |
| | | | | | | | | | Q | | | | | | | |
| GRADPE NAUTIC 30 Bronzo | 51373028 | 51383028 | 39,5 kg | TF | 230-400 | 1 | 0,75 | 1400 | 75 | 60 | 40 | 0 | | | | |
| GRADPE NAUTIC 40 Bronzo | 51374028 | 51384028 | 40,2 kg | TF | 230-400 | 1 | 0,75 | 1400 | 120 | 110 | 85 | 45 | 0 | | | |
| GRADPE NAUTIC 50 Bronzo | 51375028 | 51385028 | 49,0 kg | TF | 230-400 | 2 | 1,5 | 1400 | 230 | 210 | 175 | 125 | 85 | 0 | | |
| GRADPE NAUTIC 70 Bronzo | 51377028 | 51387028 | 110,0 kg | TF | 230-400 | 7,5 | 5,5 | 1400 | 500 | 460 | 415 | 330 | 280 | 165 | 0 | |
| | 51377128 | 51387128 | 125,0 kg | TF | 230-400 | 10 | 7,5 | 1400 | 500 | 460 | 415 | 330 | 280 | 165 | 0 | |
| GRADPE SPECIAL 30 Bronzo | 51353028 | 51363028 | 39,5 kg | TF | 230-400 | 1 | 0,75 | 1400 | 75 | 60 | 40 | 0 | | | | |
| GRADPE SPECIAL 40 Bronzo | 51354028 | 51364028 | 40,4 kg | TF | 230-400 | 1 | 0,75 | 1400 | 120 | 110 | 85 | 45 | 0 | | | |
| GRADPE SPECIAL 50 Bronzo | 51355028 | 51365028 | 48,4 kg | TF | 230-400 | 2 | 1,5 | 1400 | 230 | 210 | 175 | 125 | 85 | 0 | | |
| GRADPE SPECIAL SENIOR 1 1/2 Inox * | 60374028 | 60384028 | 40,5 kg | TF | 230-400 | 1 | 0,75 | 1400 | 120 | 110 | 85 | 45 | 0 | | | |
| GRADPE SPECIAL MASTER 2" Inox * | 60375028 | 60385028 | 48,5 kg | TF | 230-400 | 2 | 1,5 | 1400 | 230 | 210 | 175 | 125 | 85 | 0 | | |
| GRADPE NAUTIC 70 Inox * | 60377028 | 60387028 | 110,0 kg | TF | 230-400 | 7,5 | 5,5 | 1400 | 500 | 460 | 415 | 330 | 280 | 165 | 0 | |
| | 60377128 | 60387128 | 125,0 kg | TF | 230-400 | 10 | 7,5 | 1400 | 500 | 460 | 415 | 330 | 280 | 165 | 0 | |

* = Con girante in Bronzo / With Bronze impeller

** TF = Trifase / Three Phase

**GRADPE NAUTIC
30 - 40 - 50**

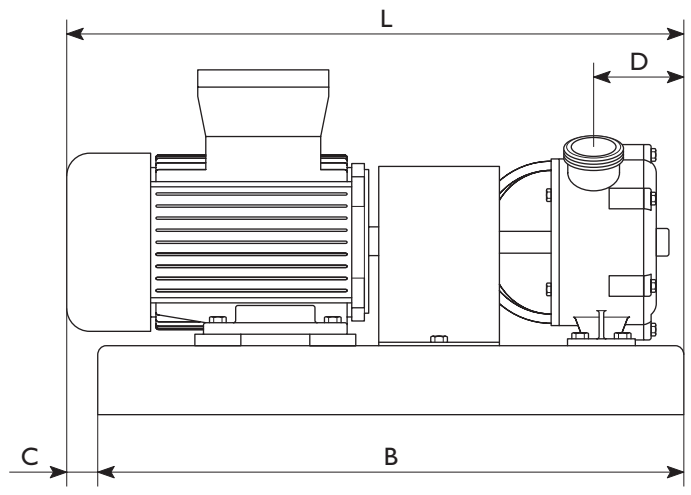
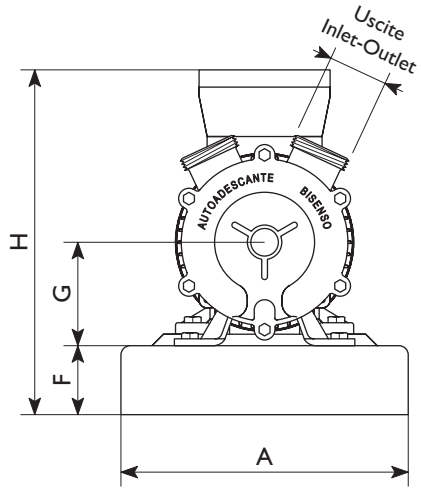

**GRADPE SPECIAL 30 - 40 - 50
SP.SENIOR 1" 1/2 - MASTER 2"**

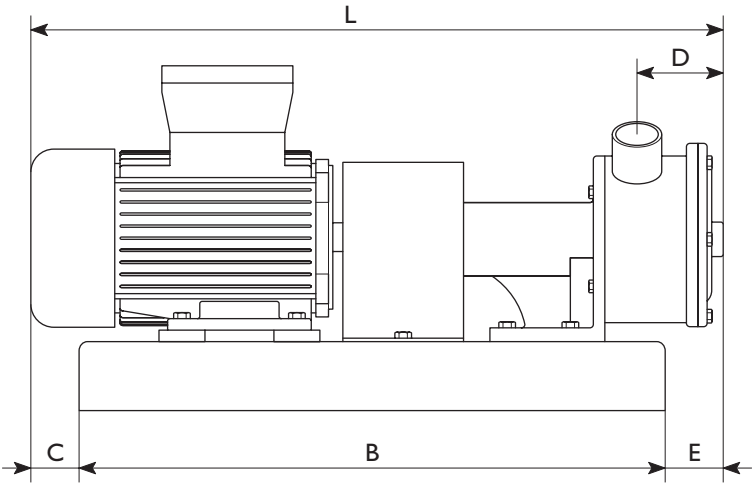
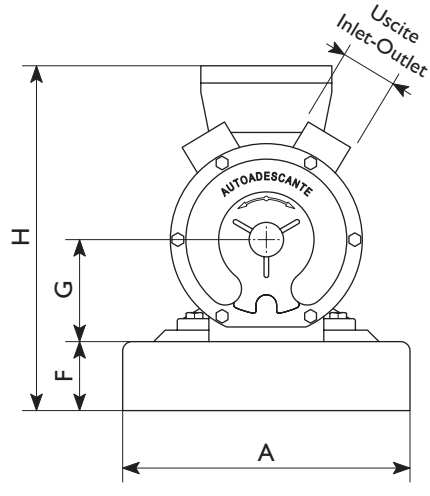

**GRADPE NAUTIC
70 - 70 Inox**

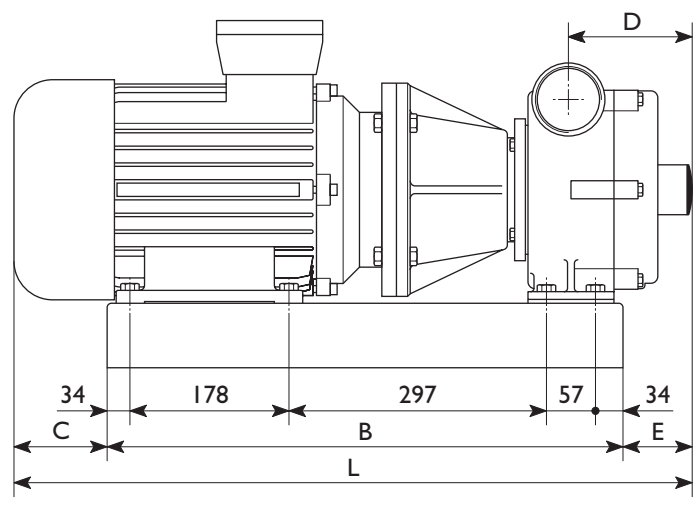
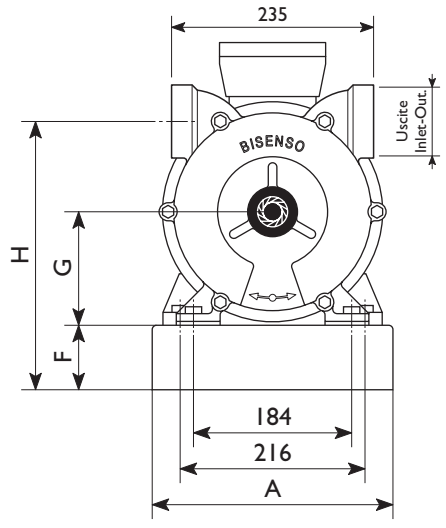

| Tipo Type | Uscite Inlet-Outlet | Raccordi Pipe fittings | Dimensioni (mm) / Dimensions (mm) | | | | | | | | |
|-------------------------------------|------------------------|---------------------------|-----------------------------------|-----|-----|-----|----|----|-----|-----|-----|
| | | | A | B | C | D | E | F | G | H | L |
| GR ADPE NAUTIC 30 | BSP-M 1"1/4 | Ø30 - Ø35 | 280 | 600 | 5 | 50 | - | 75 | 90 | 335 | 605 |
| GR ADPE NAUTIC 40 | BSP-M 1"1/2 | Ø40 - Ø45 | 280 | 600 | 5 | 67 | - | 75 | 90 | 335 | 605 |
| GR ADPE NAUTIC 50 | BSP-M 2" | Ø50 | 280 | 600 | 50 | 90 | - | 75 | 120 | 350 | 650 |
| GR ADPE NAUTIC 70 | BSP-F 2"1/2 | n.d. | 280 | 600 | 109 | 144 | 76 | 75 | 132 | 235 | 785 |
| GR ADPE SPECIAL 30 | BSP-M 1"1/4 | Ø30 - Ø35 | 280 | 600 | 5 | 50 | - | 75 | 89 | 335 | 605 |
| GR ADPE SPECIAL 40 | BSP-M 1"1/2 | Ø40 - Ø45 | 280 | 600 | 5 | 67 | - | 75 | 89 | 335 | 605 |
| GR ADPE SPECIAL 50 | BSP-M 2" | Ø50 | 280 | 600 | 50 | 90 | 15 | 75 | 107 | 350 | 665 |
| GR ADPE SPECIAL SENIOR 1"1/2 | BSP-M 1"1/2 * | Ø40 ** | 280 | 600 | 5 | 76 | - | 75 | 89 | 335 | 605 |
| GR ADPE SPECIAL MASTER 2" | BSP-M 2" * | Ø50 ** | 280 | 600 | 50 | 94 | 20 | 75 | 107 | 350 | 670 |
| GRADPE NAUTIC 70 Inox | BSP-M 2"1/2 * | n.d. | 280 | 600 | 109 | 144 | 76 | 75 | 132 | 235 | 785 |

* = Uscite standard BSP (Gas), altre uscite disponibili p.20 / Standard inlet-outlet BSP (Gas), different inlet-outlet are available see p.20

** = Raccordi in acciaio inox o nylon a richiesta / Stainless steel or nylon pipe fittings on request

n.d. = Raccordi non disponibili / Pipe fittings not available

RACCORDI ACCIAIO INOX

STAINLESS STEEL PIPE FITTINGS

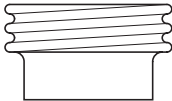
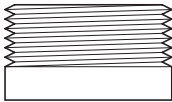
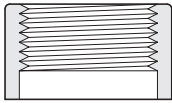
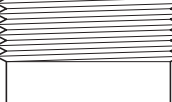
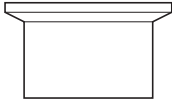
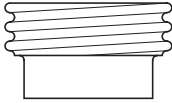
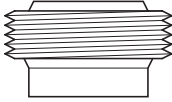
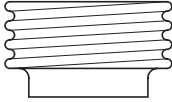
| Tipo Type | | NEOS 3/4" | JUNIOR 1"1/4 | SENIOR 1"1/2 | MASTER 2" | POMPA 70 |
|--------------|---|--|-------------------------------------|--------------------------|--|----------------------------------|
| Garolla |  | <i>Non disponibile Not available</i> | Garolla 40 | Garolla 40 | Garolla 50 | Garolla 70 Garolla 80 |
| DIN 11851 |  | DIN 20 DIN 25 | DIN 25 DIN 32 DIN 40 | DIN 32 DIN 40 | DIN 50 | DIN 65 DIN 80 |
| BSP-M |  | BSP-M 3/4" | BSP-M 1"1/4 | BSP-M 1"1/2 | BSP-M 2" | BSP-M 2"1/2 BSP-M 3" |
| BSP-F |  | <i>Non disponibile Not available</i> | BSP-F 1" | BSP-F 1"1/4 | BSP-F 1"1/2 | BSP-F 2"1/2 |
| Macon |  | <i>Non disponibile Not available</i> | Macon 40 | Macon 40 | Macon 50 | Macon 70 |
| Triclover |  | Triclover 1" | Triclover 1"1/2 | Triclover 1"1/2 | Triclover 2" | Triclover 3" |
| SMS |  | SMS 25 | SMS 38 | SMS 38 | SMS 51 | SMS 76 |
| BSM (RJT) |  | BSM 1" | BSM 1" BSM 1"1/2 | BSM 1"1/2 | BSM 2" | BSM 2"1/2 BSM 3" |
| Friederich |  | <i>Non disponibile Not available</i> | Friederich 40 | Friederich 40 | Friederich 40 Friederich 60 | Friederich 60 |



Carrello
Trolley

Carrelli e maniglie per elettropompe Trolley and handle for electric pumps



Maniglia tipo "L"
Handle "L" type



Maniglia tipo "U"
Handle "U" type

| Tipo Type | Codice Code | EP 20 | EP 25 | EP 30 | EP 40 | EP 50 | EPH/EP NEOS 3/4" | EP JUNIOR 1" 1/4 | EP SENIOR 1" 1/2 | EP MASTER 2" |
|--|----------------|-------|-------|-------|-------|-------|------------------|------------------|------------------|--------------|
| Carrello ferro zincato Zincated iron trolley | 36202002 | x | x | x | x | x | x | x | x | x |
| Carrello inox AISI 304 Stainless steel AISI 304 trolley | 36202043 | x | x | x | x | x | x | x | x | x |
| Maniglia tipo "L" Handle "L" type | 34432003 | x | x | | | | x | x | | |
| Maniglia tipo "U" Handle "U" type | 34432004 | | | x | x | | | | x | |

Valvola by-pass
By-pass valve

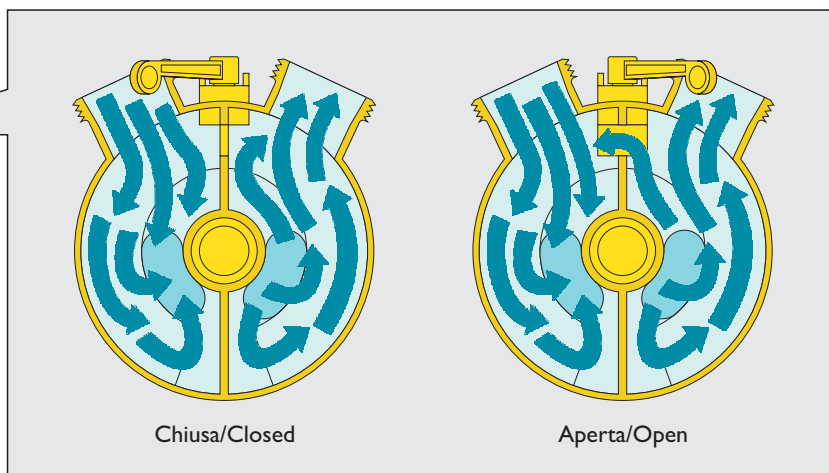

Chiusa/Closed

Aperta/Open

Morsettiera
Terminal board connection



Interruttore/invertitore
On-off/reverse switch

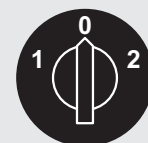

Rotativo/Rotative



Basculante/Rocker

COMPONENTI SPARE PARTS

22

| Pos. | Descrizione/Description | Materiale/Material | 20 | 25 | 30 | 40 | 50 | 70 | NEOS | JUNIOR | SENIOR | MASTER |
|--|--|--|----|----|----|----|----|----|------|--------|--------|--------|
| 1 | Vite/Screw | Inox AISI 304/Stainless steel AISI 304 | x | x | x | x | x | x | x | | x | x |
| | Cavallotto/U-bolt | Inox AISI 304/Stainless steel AISI 304 | | | | | | | | x | | |
| 1A | Vite/Screw | Inox AISI 304/Stainless steel AISI 304 | | x | x | x | x | x | | | x | x |
| 2 | Culatta/Cover | Bronzo/Bronze | x | x | x | x | x | x | | | | |
| | | Inox AISI 316/Stainless steel AISI 316 | | | | | | x | x | x | x | x |
| 3 | Guarnizione culatta/Cover rubber seal | Gomma NBR/Rubber (NBR) | x | x | x | x | x | x | x | x | x | x |
| 4 | Girante/Impeller | Bronzo/Bronze | x | x | x | x | x | | | | | |
| | | Inox AISI 316/Stainless steel AISI 316 | | | | | | | x | x | x | x |
| | Girante con albero/Impeller with shaft | Bronzo-Inox/Bronze-Stainless steel | | x | x | x | x | x | | | | |
| | | Inox AISI 316/Stainless steel AISI 316 | | | | | | x | | | | x |
| Girante con albero tipo FM/Impeller with shaft FM type | Bronzo-Inox/Bronze-Stainless steel | | | | | | x | | | | | |
| | Inox AISI 316/Stainless steel AISI 316 | | | | | | x | | | | | |
| 5 | Corpo pompa/Casing | Bronzo/Bronze | x | x | x | x | x | | | | | |
| | | Inox AISI 316/Stainless steel AISI 316 | | | | | | | x | x | x | x |
| | Corpo pompa con piedi/Casing with feet | Bronzo/Bronze | | x | x | x | x | x | | | | |
| | | Inox AISI 316/Stainless steel AISI 316 | | | | | | x | | | | x |
| 6 | Raccordo dritto con girello/Straight collector with collar | Bronzo/Bronze | x | x | x | x | x | x | | | | |
| 7 | Raccordo curvo con girello/Bent collector with collar | Bronzo/Bronze | x | x | x | x | x | x | | | | |
| 8 | Guarnizione Guarnital-Anello OR/Guarnital gasket-O ring | Guarnital | x | x | x | x | x | | x | x | x | |
| 9 | Anello di tenuta paraolio/Lip seal | Gomma NBR/Rubber (NBR) | x | x | x | x | x | x | | | | |
| | | Viton/Viton | | | | | | | | x | x | x |
| 9A | Tenuta meccanica standard/Standard mechanical seal | Ceramica, Inox-Grafite-NBR Ceramics, Stainless steel-Graphite-NBR | x | x | x | x | x | x | x | x | x | x |
| | Tenuta meccanica speciale/Special mechanical seal | Vidia-Vidia-Viton/Vidia-Vidia-Viton | x | x | x | x | x | x | | x | x | x |
| | | Vidia-Carburo di Silicio-Viton Vidia-Silicium carbide-Viton | x | x | x | x | x | x | x | x | x | x |
| 9B | Anello premistoppa/Packing ring | Baderna/Packing | | | x | x | x | | | | | |
| 10 | Chiavetta puleggia/Pulley flat key | Inox AISI 304/Stainless steel AISI 304 | x | x | x | x | x | x | | | x | x |
| 11 | Guarnizione Melinex/Melinex seal | Melinex/Melinex | x | x | x | x | x | | | | | |
| 11A | Guarnizione inox/Stainless steel seal | Inox AISI 316/Stainless steel AISI 316 | x | x | x | x | x | | x | | x | x |
| 12 | Cuscinetto/Ball bearing | Commerciale/Commercial | x | x | x | x | x | x | | | x | x |
| 13 | Anello Seeger/Seeger ring | Acciaio/Steel | x | x | x | x | x | x | | | x | x |
| 14 | Puleggia/Pulley | Alluminio/Aluminium | x | x | x | x | x | x | x | | x | x |
| | Puleggia frizione manuale/Manual clutch pulley | Ghisa/Cast iron | | | x | x | x | x | | | | |
| | Frizione magnetica/Magnetic clutch | Commerciale/Commercial | | | x | x | x | x | | | x | x |
| | Motore idraulico/Hydraulic motor | Commerciale/Commercial | | | | x | x | x | | | | x |
| 15 | Dado/Nut | Acciaio/Steel | x | x | x | x | x | x | x | x | x | x |
| 16 | Supporto SPECIAL/SPECIAL support | Peraluman | x | x | x | x | x | | x | | x | x |
| | Supporto SPECIAL FM/SPECIAL FM support | Peraluman | | | x | x | x | x | | | x | x |
| | Supporto NAUTIC/NAUTIC support | Bronzo/Bronze | | x | x | x | x | x | | | | |
| | Supporto NAUTIC F/NAUTIC F support | Bronzo/Bronze | | | x | x | x | x | | | | |
| | Supporto MID/MID support | Alluminio/Aluminium | | | | x | x | x | | | | x |
| | Supporto pompa EP 70/EP 70 pump support | Alluminio/Aluminium | | | | | | x | | | | |
| 17 | Anello di compensazione/Spacing ring | Acciaio/Steel | x | x | x | x | x | | x | | x | x |
| | Anello antisballamento MID/MID spacing ring | Ottone/Brass | | | | x | x | | | | | x |
| 18 | Cuscinetto/Ball bearing | Commerciale/Commercial | | | x | x | x | x | | | x | x |

| Pos. | Descrizione/Description | Materiale/Material | 20 | 25 | 30 | 40 | 50 | 70 | NEOS | JUNIOR | SENIOR | MASTER |
|------|---|--|----|----|----|----|----|----|------|--------|--------|--------|
| 19 | Chiavetta girante/Impeller flat key | Inox AISI 304/Stainless steel AISI 304 | x | x | x | x | x | | x | x | x | x |
| 20 | Albero SPECIAL/SPECIAL shaft | Inox AISI 316/Stainless steel AISI 316 | x | x | x | x | x | | x | | x | x |
| | Albero SPECIAL FM/SPECIAL FM shaft | Inox AISI 316/Stainless steel AISI 316 | | | x | x | x | | | | x | x |
| | Albero LALX/LALX shaft | I6CrNi4Pb | | | | x | x | | | | x | x |
| 21 | Rubinetto di spurgo/Drain cock | Ottone/Brass | | | | x | x | | | | | |
| | Tappo di spurgo/Drain plug | Ottone Nichelato/Nickel-plated brass | | | | | | | | | | x |
| | Tappo di sfiato/Sniffle plug | Commerciale/Commercial | | | | x | x | | | | x | x |
| 22 | Rondella/Washer | Inox AISI 304/Stainless steel AISI 304 | x | x | x | x | x | x | x | x | x | x |
| 23 | Coperchio/Cover | Gomma/Rubber | | x | x | x | x | x | | | | x |
| 25 | Vite/Screw | Acciaio/Steel | | | x | x | x | x | | x | x | x |
| 26 | Maniglia frizione/Clutch handle | Acciaio Zincato/Zincated steel | | | x | x | x | x | | | | |
| | Maniglia LALX/LALX handle | Acciaio Zincato/Zincated steel | | | | x | x | | | | x | x |
| 27 | Settore fisso frizione/Clutch fixed sector | Ottone/Brass | | | x | x | x | x | | | | |
| 28 | Settore mobile frizione/Clutch mobile sector | Ottone/Brass | | | x | x | x | x | | | | |
| 29 | Flangia frizione/Clutch flange | Ferro/Iron | | | x | x | x | x | | | | |
| 30 | Anello distanziale frizione/Clutch spacing ring | Inox AISI 304/Stainless steel AISI 304 | | | x | x | x | x | | | | |
| 31 | Cono frizione/Clutch cone | Ghisa/Cast iron | | | x | x | x | x | | | | |
| 32 | Cuscinetto/Ball bearing | Commerciale/Commercial | | | x | x | x | x | | | x | x |
| 33 | Anello Seeger/Seeger ring | Acciaio/Steel | | | x | x | x | x | | | | |
| 34 | Bussola frizione/Clutch bush | Acciaio/Steel | | | x | x | x | x | | | | |
| 35 | Molla frizione/Clutch spring | Acciaio/Steel | | | x | x | x | x | | | | |
| 36 | Coperchio frizione/Clutch cover | Alluminio/Aluminium | | | x | x | x | x | | | | |
| 37 | Culatta posteriore EP JUNIOR/EP JUNIOR rear cover | Inox AISI 316/Stainless steel AISI 316 | | | | | | | | x | | |
| | Campana pompa EP 70 / EP 70 pump flange | Ghisa/Cast iron | | | | | | x | | | | |
| 38 | Anello Seeger/Seeger ring | Acciaio/Steel | | | | x | x | | | | | x |
| 39 | Manicotto dentato /Geared coupling | Acciaio C40/Steel C40 | | | | x | x | | | | | x |
| | Manicotto di collegamento/Connecting coupling | Nylon/Nylon | | | | | | x | | | | |
| 40 | Ingranaggio conico/Bevel gear | Acciaio/Steel | | | | x | x | | | | | x |
| 41 | Guarnizione Guarnital LALX/LALX guarnital gasket | Guarnital | | | | x | x | | | | | x |
| 42 | Dado/Nut | Acciaio/Steel | | | x | x | x | x | | | x | x |
| 43 | Giunto coassiale pompa/Pump coaxial coupling | Acciaio/Steel | | | | | | x | | | | |
| 44 | Anello di tenuta paraolio/Lip seal | Gomma NBR/Rubber (NBR) | | | | x | x | | | | x | x |
| 45 | Anello di tenuta paraolio/Lip seal | Gomma NBR/Rubber (NBR) | | | | x | x | | | | x | x |
| 46 | Scatola moltiplicatore LALX/LALX overdrive | Alluminio/Aluminium | | | | x | x | | | | x | x |
| 47 | Anello di tenuta paraolio/Lip seal | Gomma NBR/Rubber (NBR) | | | | x | x | | | | x | x |
| 48 | Indicatore livello olio/Oil level indicator | Commerciale/Commercial | | | | x | x | | | | x | x |
| 49 | Spina conica/Taper pin | Acciaio/Steel | | | | x | x | | | | x | x |
| 50 | Anello antispallamento/Spacing ring | Acciaio/Steel | | | | x | x | | | | x | x |
| 51 | Ingranaggio conduttore LALX/LALX driving gear | I6CrNi4 | | | | x | x | | | | x | x |
| 52 | Vite/Screw | Acciaio/Steel | | | x | x | x | x | | | x | x |
| 53 | Flangia premistoppa/Packing flange | Bronzo/Bronze | | | x | x | x | | | | | |
| 54 | Vite prigioniero/Screw | Acciaio/Steel | | | x | x | x | | | | | |
| 55 | Giunto coassiale motore/Motor coaxial coupling | Acciaio/Steel | | | | | | x | | | | |
| 56 | Giunto coassiale motore/Motor coaxial coupling | Acciaio/Steel | | | | | | x | | | | |
| 57 | Giunto coassiale pompa/Pumpa coaxial coupling | Alluminio/Aluminium | | | x | x | x | | | | x | x |
| 58 | Anello giunto/Coupling ring | Gomma/Rubber | | | x | x | x | | | | x | x |
| 59 | Giunto coassiale motore/Motor coaxial coupling | Alluminio/Aluminium | | | x | x | x | | | | x | x |

SPECIAL / SPECIAL FM / ADPE

SPECIAL 20 - 25
SPECIAL NEOS 3/4"

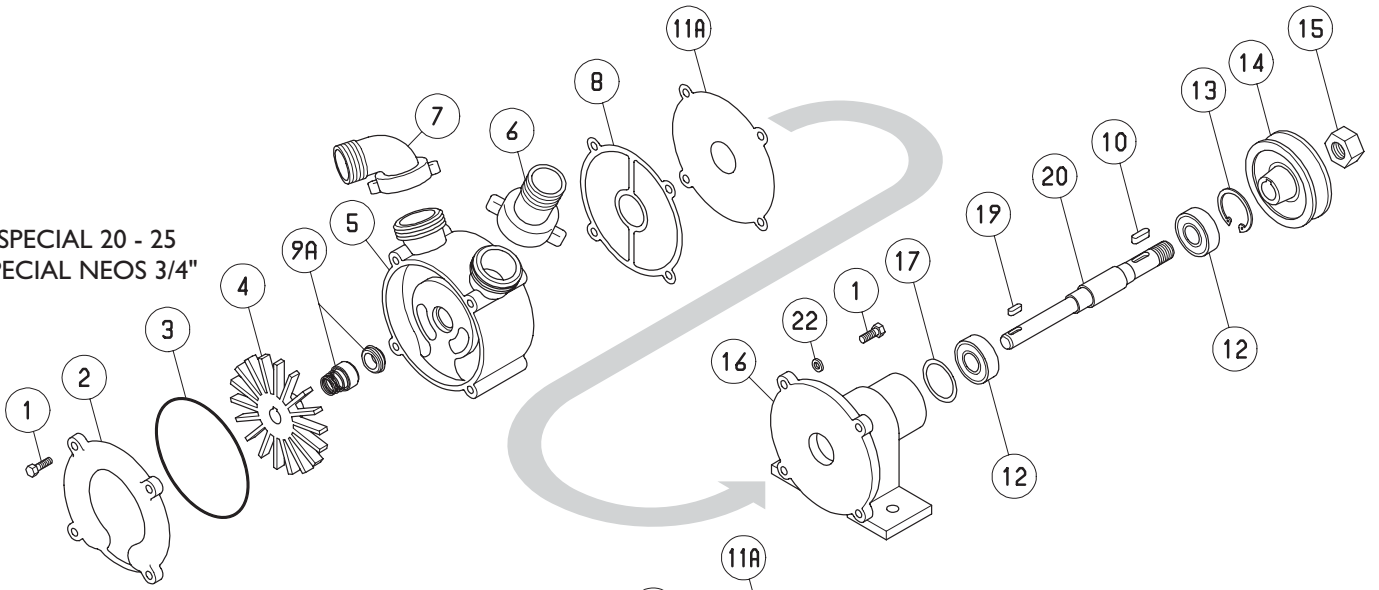

SPECIAL/SPECIAL FM/ADPE
30 - 40 - 50

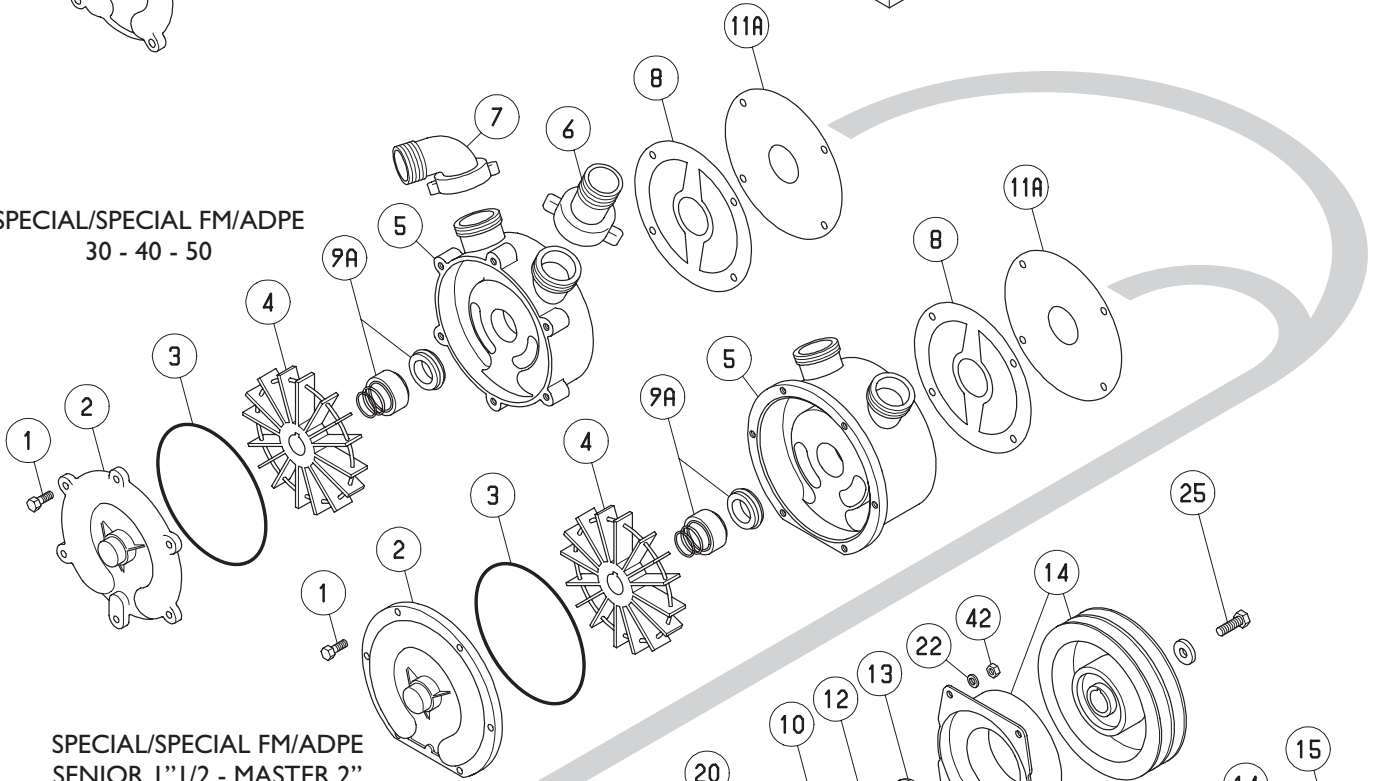

SPECIAL/SPECIAL FM/ADPE
SENIOR 1 1/2" - MASTER 2"

SPECIAL FM

SPECIAL

SPECIAL ADPE

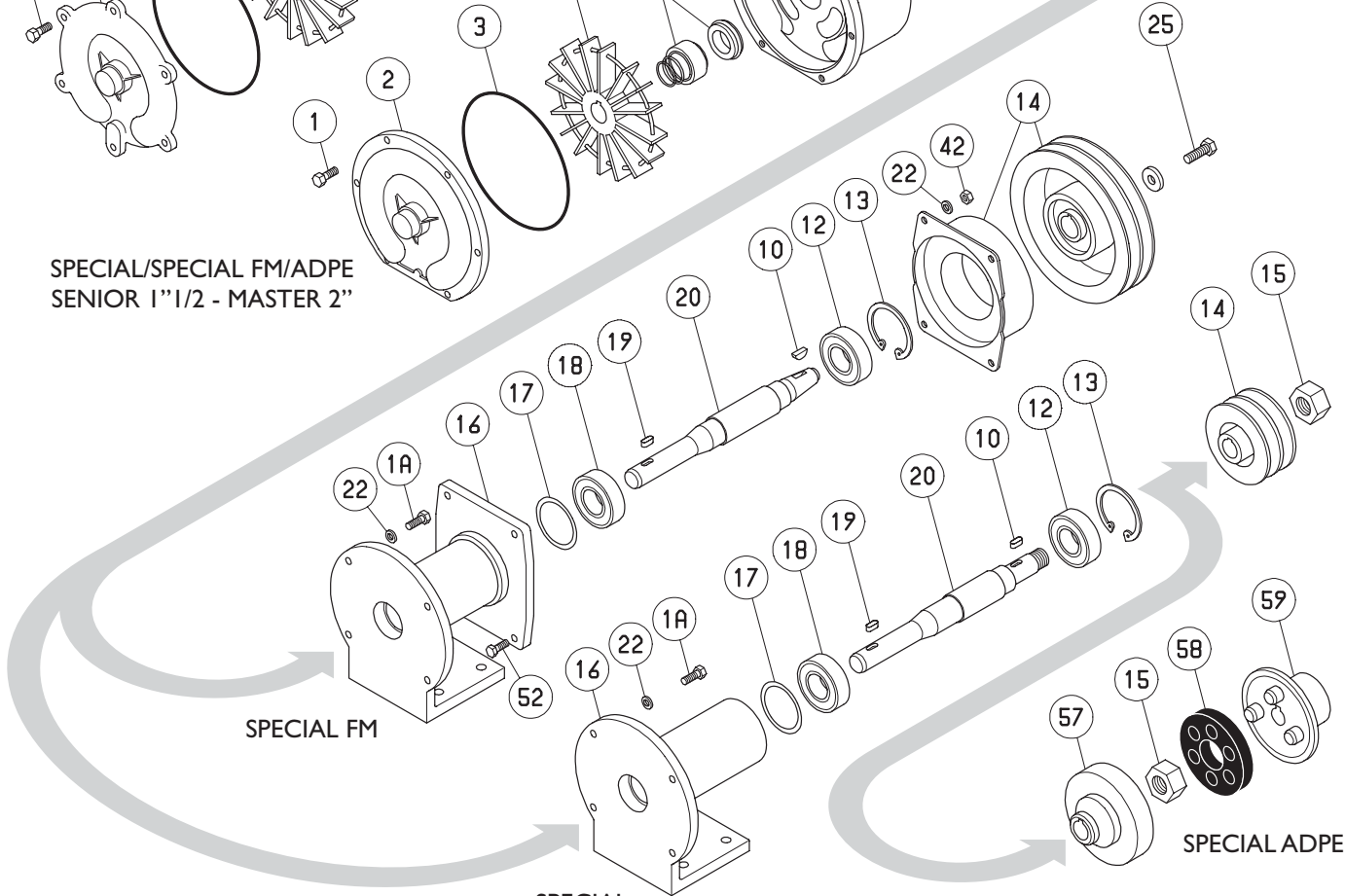

NAUTIC / NAUTIC F / ADPE

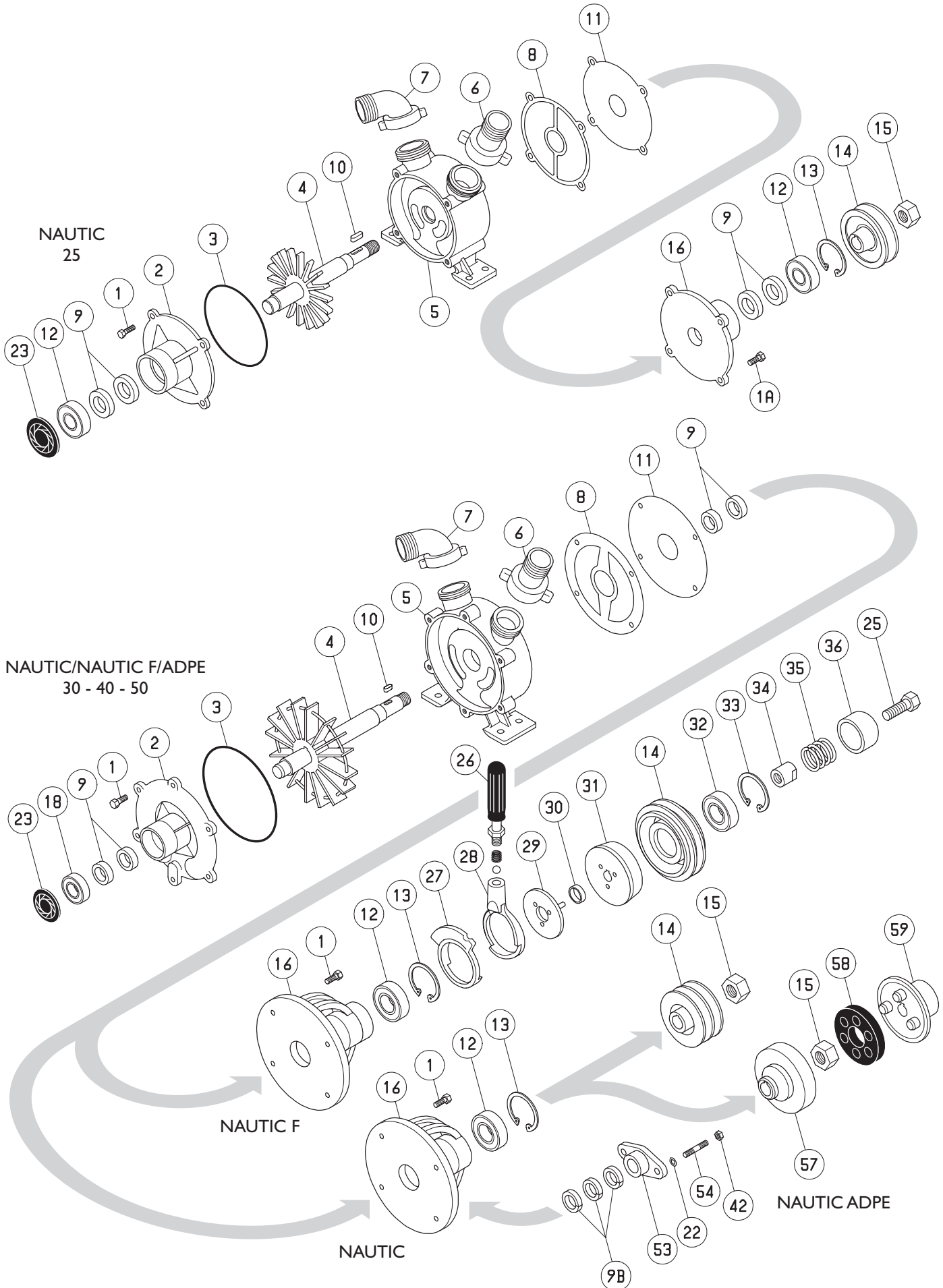

MID

MID
40 - 50

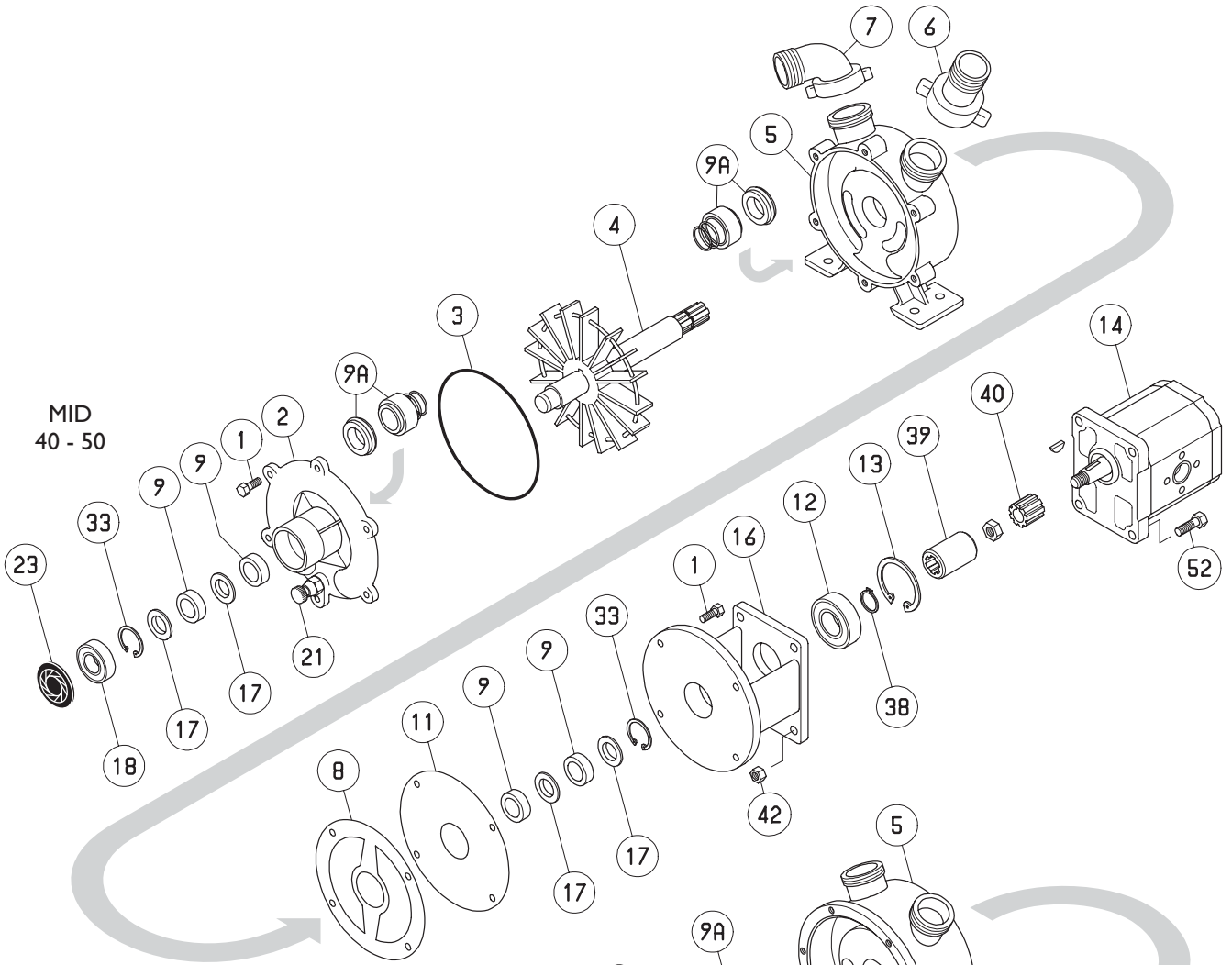

MID
MASTER 2"

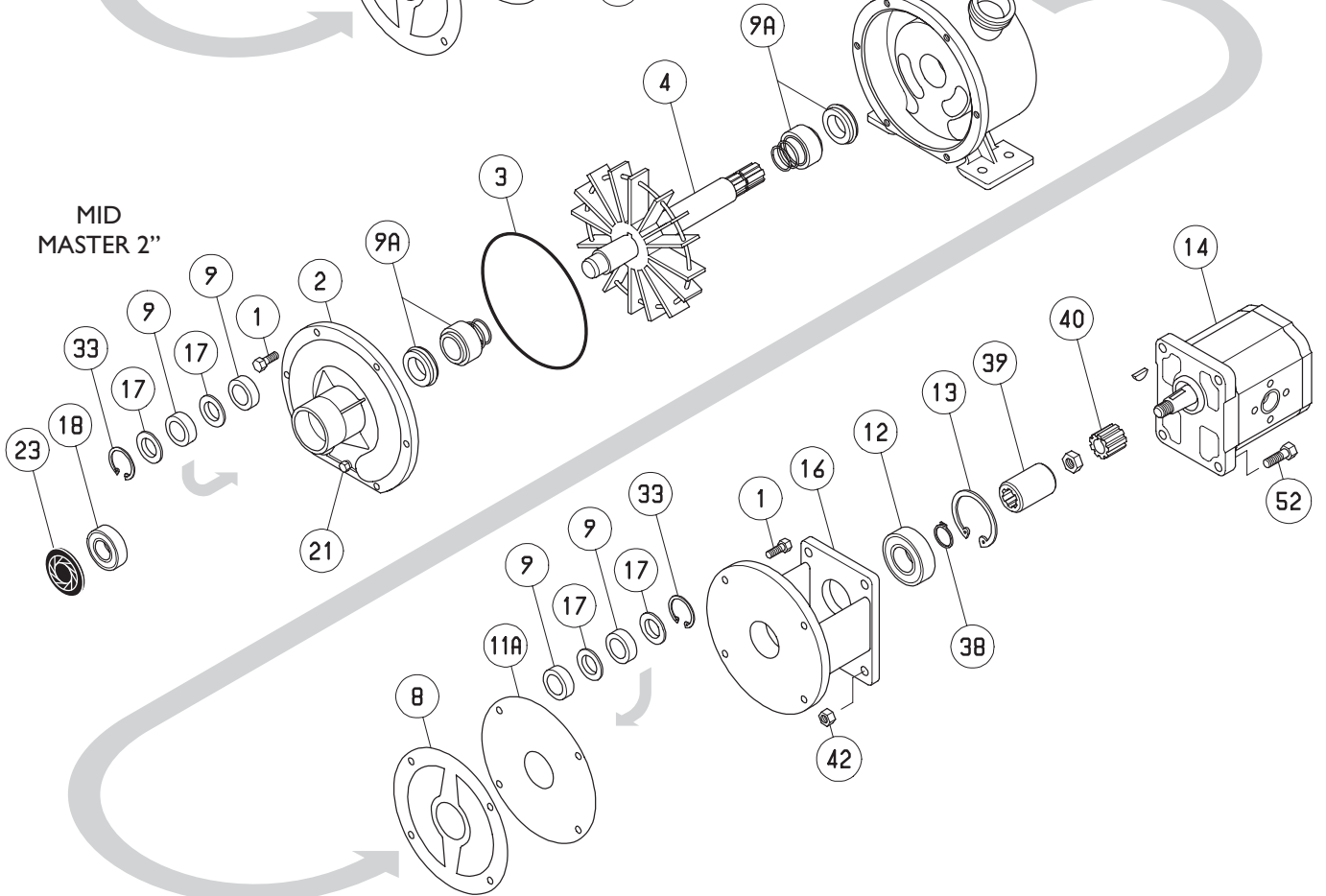

POMPA 70

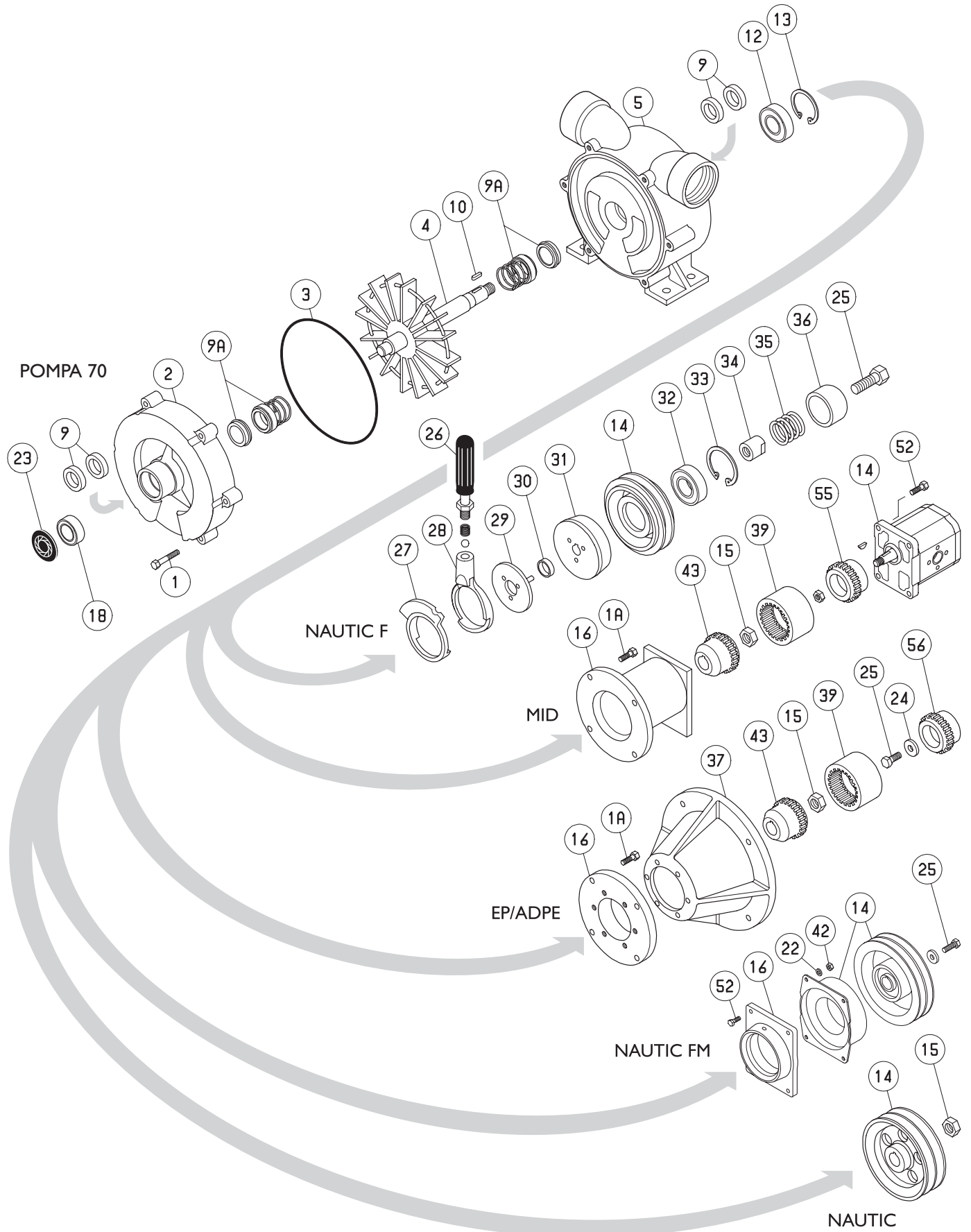

LALX

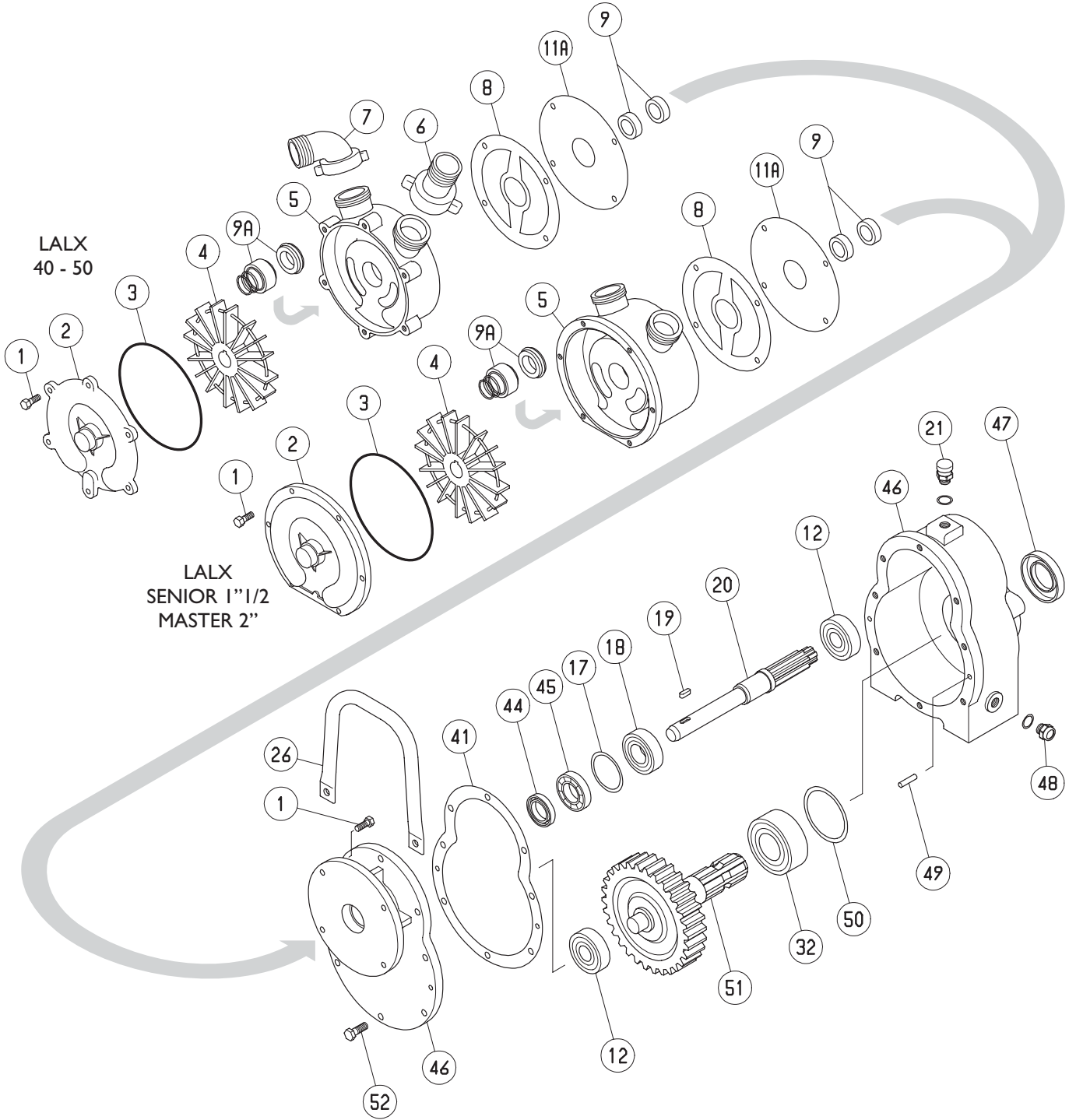

EP

EPH/EP
NEOS 3/4"

EPH/EP
20 - 25

EP JUNIOR

EP
30 - 40 - 50

EP SENIOR 1 1/2"
EP MASTER 2"

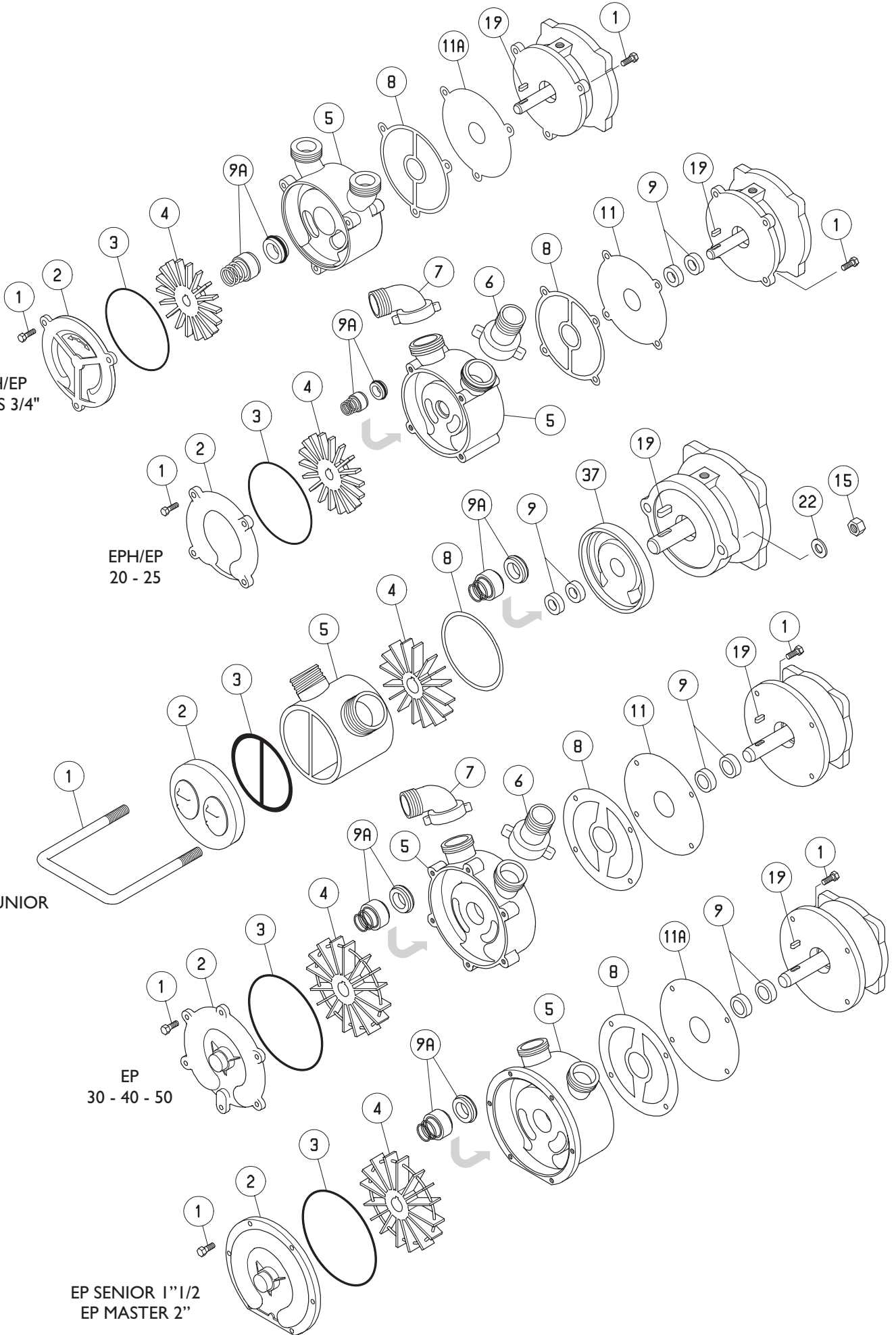



LIVERANI

motralec

4 rue Lavoisier . ZA Lavoisier . 95223 HERBLAY CEDEX
Tel. : 01.39.97.65.10 / Fax. : 01.39.97.68.48
Demande de prix / e-mail : service-commercial@motralec.com
www.motralec.com