

# Liquiflo **POLY-GUARD™** SERIES Polymer-Lined Stainless Steel Gear Pump

## The **Ultimate Solution** for Pumping **Corrosive Chemicals**

Combines the chemical resistance of Fluoro-Polymer with the strength of Stainless Steel

### THE TOUGHEST EXTERIOR

An extremely durable 300-Series Stainless Steel body clearly sets the Poly-Guard™ apart from all other plastic pumps. Its strong and chemically resistant body truly makes the Poly-Guard™ the perfect match for harsh industrial environments.

- STAINLESS STEEL FLANGES
- STAINLESS STEEL BODY
- ALLOY-C CONTAINMENT CAN

### THE MOST CHEMICALLY RESISTANT INTERIOR

**Fluoro-Polymer Plastic Lining** resists the most corrosive chemicals

All inside surfaces contain a molded layer of Fluoro-Polymer – the most chemically resistant of all plastics. This layer (shown in yellow) is molded, mechanically fastened and chemically bonded to the Stainless Steel outer casing; then precision-machined to close tolerances.

This combination of the toughest exterior and the most chemically resistant interior is the ultimate solution for your most difficult pumping applications.

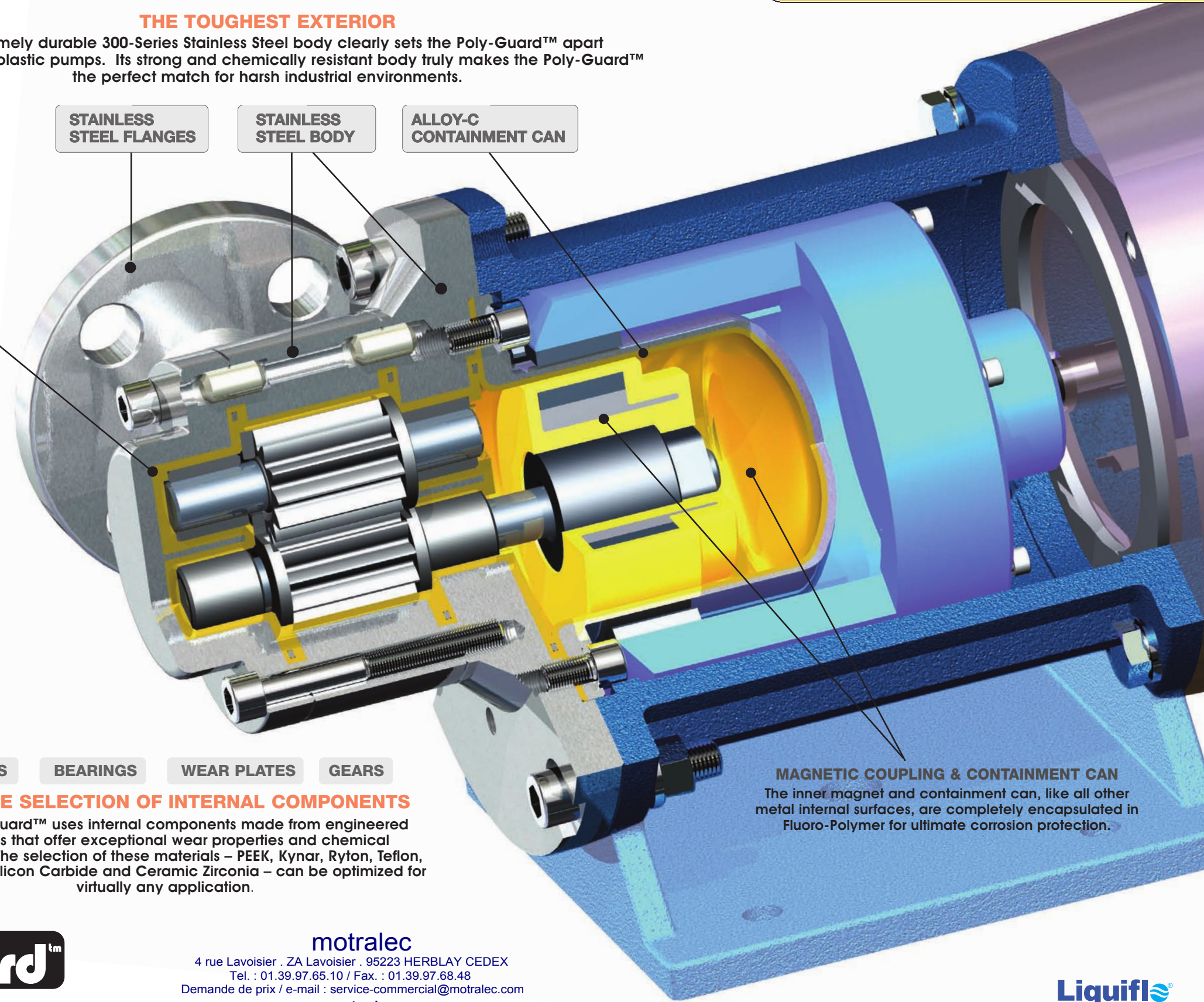

### THE FLUORO-POLYMER LINER

The interior walls of the Stainless Steel housing are encased with perfluoroalkoxy plastic, which is a type of Fluoro-Polymer commonly known by its acronym, PFA. PFA was chosen because it's the most chemically resistant of all moldable plastics. In the Poly-Guard™ design, the PFA is supported by the Stainless Steel housing; therefore, no additional reinforcements (such as fiber fillers which are necessary to strengthen an all plastic pump) are needed. In fiber reinforced plastic pumps, these fillers can significantly reduce the chemical resistance of the plastic and potentially allow wicking of the chemical along the fiber matrix.

### INTERNAL COMPONENTS

The Poly-Guard™ pump is offered with a wide selection of materials for its internal components. With Liquiflo's 35 years of experience in pumping extremely difficult chemicals, we can maximize the performance and reliability of the Poly-Guard™ for virtually any application. In several applications, by optimizing component selection, Liquiflo has exceeded 40,000 hours of MTBR.

**SHAFTS** Self-Sintered Silicon Carbide (SiC) or Transformation Toughened Zirconia (TTZ) Shafts for extreme wear resistance and chemical resistance.

**BEARINGS** Silicon Carbide Bearings for extreme life and wear resistance, or Carbon 60 Bearings for flexibility and dry-running capability.

**GEARS** Choice of PEEK, Kynar, Ryton or Teflon Gears to optimize performance for chemical applications.



**CONTAINMENT CAN** The standard containment can is made of Alloy-C, a high nickel alloy which is 40% stronger than Stainless Steel. Alloy-C has the added benefit of minimizing magnetically induced eddy current power losses that can add heat to the pumped product. The Poly-Guard™ is also offered

with an optional Carbon Fiber containment can for complete elimination of eddy current losses.

### REPAIR KITS

These pumps are extremely simple to repair and maintain. Either individual parts or complete repair kits that contain all internal components are available to economically rebuild the pump to like-new condition.



- SHAFTS
- BEARINGS
- WEAR PLATES
- GEARS

### FLEXIBLE SELECTION OF INTERNAL COMPONENTS

The Poly-Guard™ uses internal components made from engineered materials that offer exceptional wear properties and chemical resistance. The selection of these materials – PEEK, Kynar, Ryton, Teflon, Carbon 60, Silicon Carbide and Ceramic Zirconia – can be optimized for virtually any application.

**MAGNETIC COUPLING & CONTAINMENT CAN**  
The inner magnet and containment can, like all other metal internal surfaces, are completely encapsulated in Fluoro-Polymer for ultimate corrosion protection.



**motralec**  
4 rue Lavoisier . ZA Lavoisier . 95223 HERBLAY CEDEX  
Tel. : 01.39.97.65.10 / Fax. : 01.39.97.68.48  
Demande de prix / e-mail : [service-commercial@motralec.com](mailto:service-commercial@motralec.com)  
[www.motralec.com](http://www.motralec.com)

