

PRODUCT CATALOG

& Engineering Reference

2009 EDITION

Gear & Centrifugal Pumps

316 SS, Alloy-20, Alloy-C, Titanium & PFA-Lined SS

SEALED & MAGNETIC DRIVE



Aniline • Potassium Permanganate • Citric Acid
Paraffin • Mineral Oil • Toluenesulfonic Acid
Asphalt • Tartaric Hydroxide • Calcium
Bromine • Sulfuric Acid
Copper • Barium
Hydrogen Peroxide • Dioxane
Ammonium Hydroxide • Benzene
Hydrofluoric Acid • Hydrochloric Acid
Diethylamine • Phosphoric Acid
Nitrous Acid • Freon, general • Naphthalene
Isopropyl Alcohol • Carbon Disulfide • Hydro



Methyl Ethyl Ketone (MEK) • Chromic Acid, 30%
Acetone • Perchloroethylene • Ethylene Glycol
Sodium Bicarbonate • Sulfuric Acid
Butyl Alcohol • Sodium Ammonium
Pyridine • Water, deionized • anhydrous
Hexane • Ether • Benzene
Perchloroethylene • Acetaldehyde
Toluene • Pentane • Benzene
Alcohol • Silicic Acid • Sodium Chlorate
Ethylene Oxide • Ammonia, anhydrous • Sulfuric
Vinyl Chloride • Potassium Nitrate • Glycerin
Carbon Tetrachloride • Diesel Fuel • Butadiene



Sodium Chloride • Aluminum Potassium
Trichlorotrifluoroethane • Ethylene Glycol
Ammonium Nitrate • Methylene Chloride
Aluminum Chloride
Oxalic Acid • Sulfuric Acid
Trichloroethylene • 75% • Acetic Acid
Acetic Acid, 50% • Hydrochloric
Glucose (Corn Syrup) • Hydrochloric
Xylene • Methanol • Sodium Hydroxide, 50%
Aluminum Sulfate • Nitric Acid, 20% • Oleic

Sulfuric Acid, 10-75% • Amyl Acetate • Tallow
Hydrogen Peroxide, 50% • Glucose (Corn Syrup)
Glycerin • Hydrochloric Acid, 37% • Methanol
Sodium Hydroxide, 50% • Aluminum Sulfate
Nitric Acid, 20% • Oleic Acid • Benzene • Styrene
Cyclohexane • Xylene • Pentane • Water, deionized
Ammonium Sulfate • Pyridine • Sulfur, molten
Jet Fuel • Acetonitrile • Maleic Acid • Urea •
Tetrahydrofuran (THF) • Ferric Sulfate • Hydro
Chloroform • Potassium Nitrate • Vinyl Chloride
Benzoic Acid • Gasoline • Toluene • Silver Nitrate
Naphthalene • Acetic Acid • Propylene Glycol
Kerosene • Sulfuric Acid, 93-100% • Butyl Acetate • Ethyl
Lactic Acid • Tall Oil (Liquid Rosin) • Phenol •
Butane • Hydrobromic Acid, 20% • Oleum •
Trichloroethane • Bitumen • Calcium Hydroxide
Hydrochloric Acid • Brine (NaCl & Water) •
Cyclohexanol • Fluorosilicic Acid • Potassium

motralec
4 rue Lavoisier, ZA Lavoisier, 95223 HERBLAY CEDEX
Tel. : 01.39.97.65.10 / Fax : 01.39.97.68.48
Demande de prix / e-mail : service-commercial@motralec.com
www.motralec.com



For Over 35 Years, Liquiflo
Pumps Have Handled Thousands
of Difficult Chemicals

Benzene • Cyclohexane • Butane • Pentane •
Water, deionized • Ammonium Sulfate • Pyridine
Sulfur, molten • Jet Fuel • Acetonitrile • Maleic
Urea • Tetrahydrofuran (THF) • Ferric Sulfate
Hydrazine • Ethanol • Sodium Hypochlorite,
Chloroform • Potassium Nitrate • Vinyl Chloride
Benzoic Acid • Gasoline • Toluene • Silver Nitrate
Naphthalene • Acetic Acid • Propylene Glycol
Kerosene • Sulfuric Acid, 93-100% • Butyl Acetate

INTRODUCTION 2009 EDITION

For over 35 years,
**Liquiflo pumps have handled
 thousands of difficult chemicals**

443 North Avenue
 Garwood
 New Jersey
 07027
 USA

tel. 908.518.0777
 fax. 908.518.1847
Liquiflo.com

Liquiflo specializes in the design and manufacture of high-alloy gear pumps and centrifugal pumps for the chemical processing industry. Our extensive experience and wide offering of corrosion and wear resistant materials enable us to engineer pumps capable of handling some of the most difficult and challenging chemical applications. These include pumping acids, caustics, corrosive salts, solvents, polymers and other types of chemicals, as well as hot or cold, viscous, extremely thin and hazardous liquids.

Liquiflo offers a large selection of standard Sealed and Mag-drive pumps (see chart below), repair kits, parts, options and accessories, which are available for immediate delivery. In addition, Liquiflo can customize pumps to meet your specific requirements. Our experienced application engineers, customer service representatives and worldwide network of distributors are available to assist you with your special chemical pumping applications.

This 153-page, full-color catalog describes Liquiflo's extensive product offering in a clear and easy-to-understand format. A useful and comprehensive Engineering reference is included in the second part of the catalog. New to the 2009 edition are improved General Information and Engineering sections, the expanded H-Series – including the new H12 Close-Coupled Pumps, the addition of the new Max® Series High-Pressure Gear Pumps, and the new Centry® Series Centrifugal Pumps.

OVERVIEW of LIQUIFLO GEAR & CENTRIFUGAL PUMP FAMILIES

GEAR PUMPS					CENTRIFUGAL PUMPS
General Purpose Gear Pumps		Special Purpose Gear Pumps			
H-Series	3-Series *	2-Series	4-Series	Max® Series	Centry® Series
Heavy-Duty Industrial	Standard-Duty	Ultra-Low-Flow	Low-Flow	High-Pressure	Sub-ANSI
<ul style="list-style-type: none"> • 11 sizes • Sealed • Mag-Drive 	<ul style="list-style-type: none"> • 11 sizes • Sealed • Mag-Drive 	<ul style="list-style-type: none"> • 2 sizes • Mag-Drive 	<ul style="list-style-type: none"> • 4 sizes • Mag-Drive 	<ul style="list-style-type: none"> • 9 sizes • Sealed • Mag-Drive 	<ul style="list-style-type: none"> • 3 sizes • Sealed • Mag-Drive
Maximum Flow Rates (approx.)					
• 30 GPM	• 55 GPM	• 30 GPH	• 3.5 GPM	• 20 GPM	• 150 GPM
Maximum Differential Pressures					
• 225 PSI	• 100 PSI	• 225 PSI	• 100 PSI	• 350 PSI	• 100 ft (head)
Basic Materials of Construction					
<ul style="list-style-type: none"> • 316 SS • Alloy-C 	<ul style="list-style-type: none"> • 316 SS • Alloy-C • Alloy-20 	• 316 SS	<ul style="list-style-type: none"> • 316 SS • Alloy-C • Titanium 	<ul style="list-style-type: none"> • 316 SS • Titanium 	<ul style="list-style-type: none"> • 316 SS • Alloy-C

* The 3-Series was replaced by the H-Series; the H-Series is recommended for all new applications and 3-Series upgrades.

PRODUCT CATALOG

2009 Edition

TABLE OF CONTENTS

GENERAL INFORMATION



Introduction to Liquiflo	2-7
Attributes & Advantages of Gear Pumps	8-10
Gear Pumps in Metering, Circulation & Transfer Applications	11
Liquiflo Gear Pump Families & Available Materials of Construction	12-15
Wear Resistant Materials: Hard-Coated Shafts & Silicon Carbide Bearings	16-17
Close-Coupled Configuration	18
Seal Configurations	19
Maintenance & Repair Options	20-21
Options & Accessories	22-23
Application Case Histories for Liquiflo Gear Pumps	24-27

GEAR PUMPS

GENERAL PURPOSE GEAR PUMPS

The **H-Series Heavy-Duty Industrial Gear Pumps** are available in Sealed & Mag-drive versions with flows up to approximately 30 GPM and differential pressures up to 225 PSI (with 300 PSI possible on some models). The H-Series was designed as an upgrade to the 3-Series and is recommended for all new applications as well as an upgrade to any existing 3-Series installations.

Liquiflo's original **3-Series Standard-Duty Gear Pumps** are available in Sealed & Mag-drive versions with flows up to approximately 55 GPM and differential pressures up to 100 PSI.

SPECIAL PURPOSE GEAR PUMPS

The **2-Series Ultra-Low-Flow Gear Pumps** are available in Mag-drive configuration with flows up to 30 GPH (0.5 GPM) and differential pressures up to 225 PSI. Their compact and rugged design makes them ideal for many applications, including chemical dosing and metering, pipeline sampling and wastewater treatment.

The **4-Series Low-Flow Gear Pumps** are available in Mag-drive configuration with flows up to 3.5 GPM and differential pressures up to 100 PSI. These pumps were designed for compact OEM applications, such as chemical feed systems, and offer a large selection of materials to cover a wide variety of chemical applications.

The **Max-Series High-Pressure Gear Pumps** are available in Sealed & Mag-drive versions with flows up to 20 GPM and differential pressures up to 350 PSI. These pumps feature helical gears and relieved wear plates for smoother and quieter operation, solid machined housings and heavy-duty bolting. Their unique and durable design will ensure extended life in high-pressure pumping applications.

Liquiflo's **Centry-Series Sub-ANSI Centrifugal Pumps** are available in Sealed and Mag-drive versions with flows up to ~150 GPM and heads up to 100 ft. These pumps were designed for chemical, agricultural, general industrial and OEM applications. The Centry-Series pumps feature heavy-walled, corrosion-resistant casings for extended life when pumping aggressive chemicals, and a back-pullout design to simplify maintenance.

H-Series

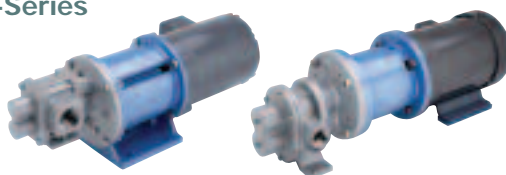

General Information	28-29
Model Coding	30-31
Specification Sheets	32-42

3-Series



General Information	44-45
Model Coding	46-47
Specification Sheets	48-58

2-Series



General Information	60
Model Coding	61
Specification Sheet	62

4-Series



General Information	63
Model Coding	64
Specification Sheet	65

Max®-Series



General Information	66-67
Model Coding	68
Specification Sheets	69-77

CENTRIFUGAL PUMPS

Centry®-Series

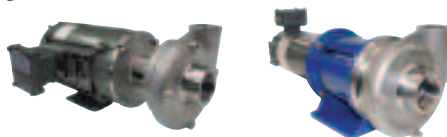

General Information	78-79
Model Coding	80
Specification Sheets	81-83

SPECIALTY PUMPS

ENGINEERING

DISTRIBUTION

84-85

86-152

153

WHO IS LIQUIFLO?

Liquiflo is a division of Picut Industries with headquarters located in Garwood, NJ, USA. Picut Industries is a privately owned conglomerate of companies that produces precision products for the chemical, aerospace, automotive, electronics and commercial manufacturing industries. Picut Industries has over 350 employees and approximately 280,000 square feet of modern manufacturing facilities. (For more information on Picut Industries, please refer to the following website: www.picutindustries.com)

Since 1972, Liquiflo has manufactured high-alloy gear pumps and centrifugal pumps – designed specifically to meet the demanding requirements of the chemical processing industry. Liquiflo gear pumps have handled thousands of difficult chemicals and have been successfully applied in many difficult pumping situations, including low-viscosity, high-viscosity, low-temperature and high-temperature applications.

One of Liquiflo's strengths is the application of gear pumps to low-viscosity fluids by using a wide variety of non-metallic, self-lubricating components. In addition, Liquiflo was one of the first companies to apply magnetic-drive technology to gear pumps. By focusing mainly on chemical applications, Liquiflo has earned the reputation as one of the world's leading pump companies.

WHY CHOOSE LIQUIFLO?

THE LIQUIFLO ADVANTAGE

- For decades, Liquiflo has led the field in engineered pumps designed to meet customer needs for metering, circulation and transfer of process fluids. Our pumps provide high reliability for handling difficult services, including high-temperature, high-pressure and low-flow chemical applications. The benefits to the customer include increased uptime, high operational effectiveness and less frequent service requirements.
- Liquiflo has over 35 years experience pumping thousands of difficult chemicals including acids, caustics, corrosive salts, solvents, polymers and other types of chemicals, as well as hot or cold, viscous, extremely thin and hazardous liquids. To date, Liquiflo has sold well over 100,000 pumps for thousands of different applications around the globe.
- Liquiflo offers a wide selection of standard high-alloy gear and centrifugal pumps to handle a variety of chemical applications. In addition, Liquiflo can custom engineer pumps to meet your specific requirements.
- Most Liquiflo pumps models have the choice of any sealing, mounting and port configurations: Sealed vs. Mag-drive; long-coupled vs. close-coupled; threaded vs. flanged ports.
- Liquiflo offers a large selection of ancillary options and accessories. These include repair kits, pump cartridges, ANSI & DIN flanges, sanitary fittings, temperature-control jackets, relief valves, electric or air motors, variable speed drives, gearboxes, base plate mounting, and more.
- Liquiflo's conscientious and efficient operation ensures that quality products will reach our customers in the fastest time possible. Standard products and parts can usually be shipped in 1 to 3 workdays.
- Liquiflo's comprehensive, full-color product literature is available in hardcopy form upon request, and is also available electronically on our website: www.liquiflo.com. Our website supports all standard Liquiflo pump models, including the Endura family of magnetically-driven centrifugal pumps.
- Liquiflo offers the following special options: custom assemblies, certified or custom drawings, Certificate of Conformance, Foundry Certified Material Test Reports, witnessed performance and hydrostatic testing, and custom tagging.
- Liquiflo's experienced application engineers, customer service representatives and worldwide network of distributors are always available to assist you with your special chemical pumping applications.

 INTRODUCTION TO LIQUIFLO

What are some of the typical markets and applications served by Liquiflo?

MARKETS SERVED	Some Applications
Adhesives & Coatings	Low-flow dispensing (glue for folding boxboards, parts assembly using glue instead of fasteners), spray coating with nozzles, difficult to handle ingredients (fast drying acrylic emulsions, isocyanates, solvents, plasticizers)
Chemical Plants	Loading & unloading, process production areas, utilities (water, wastewater and boiler feedwater treatment), pilot plants, polymer manufacturing, monomers, DI water, defoamers, catalysts, dyes, odor control additives, specialty chemicals
Fertilizers	Nitric acid, sulfuric acid, phosphoric acid, ammonia, production of urea-ammonium nitrate (UAN)
Food & Dairy	Canneries, dairies, meat processing, snack foods, raw material handling (salt and brine solutions, vinegar, sugar solutions, additives), utilities (water, wastewater and boiler feedwater treatment; clean-in-place systems dispensing cleansing chemicals)
Iron & Steel Mills	Utilities (water, wastewater and boiler feedwater treatment), acids for pickling, acids and caustic solutions for finishing
Metal Finishing	Surface cleaning (alkaline and caustic to degrease, rinse aids, neutralizing chemicals), zinc coatings (acids for pickling, zinc phosphate), electroplating (nickel or copper solutions), anodizing, passivation (bath in nitric or citric acid solutions)
Mining & Minerals	Extraction (acids, solvents), reaction to cause precipitation (caustics), coagulation for solids-liquid separation (polymers)
Municipalities	Production of drinking water (flocclants, alum, sodium hypochlorite for disinfection), wastewater treatment (polymer for coagulating suspended solids, sludge conditioning, sodium hypochlorite for disinfection of discharged treated water)
Personal & Household Products	Soap, laundry detergent, fabric conditioner, dishwasher detergent, household cleaners, dyes, fragrances, surfactants
Pesticides	Dilution into final product, incorporation of pesticide solution into dry product
Pharmaceuticals	Bulk chemical handling (hydrochloric acid, solvents), utilities (cooling tower water treatment, boiler feedwater treatment, wastewater chemical treatment, pumping high purity water)
Power Plants & Utilities	Boiler feedwater treatment chemicals, makeup water system regeneration, biocides for cooling tower water
Printing	Inks for printing press manufacturers, publishers with printing operations and OEM's that build printing presses
Pulp & Paper	Retention & drainage aids, biocides, wet strength additives, dry strength additives, coating polymers, sizing, pigments & fillers, bleaching chemicals
Refineries	Utilities (water, wastewater and boiler feedwater treatment), solvent extraction processes (phenol or furfural to remove aromatics), chemical treatment (caustic solutions for removing sulfuric acid), fuel additives (ethanol and ethers)
Textiles	Bleaching chemicals (hydrogen peroxide), caustics, fabric conditioners, dyes, utilities (water, wastewater and boiler feedwater treatment)
OEMs (Original Equipment Manufacturers)	Chemical metering systems, chillers, air-conditioning & refrigeration units, constant temperature baths, printing presses, liquid dispensers (soaps, glues, paints, etc.)

Location & Resources



Headquartered in Garwood, NJ, Liquiflo's resources include a highly skilled workforce and spacious manufacturing facilities equipped with high-tech machinery and instrumentation. Liquiflo is also supported by our network of technically astute domestic and international distributors.



The "Flo" of Liquiflo

Liquiflo's conscientious and efficient approach to manufacturing ensures that quality products will reach our customers in the fastest time possible. Our large inventory of parts and products enables us to ship over 90% of what we offer in just 1 to 3 workdays.

"The Liqui-Flo Chart"

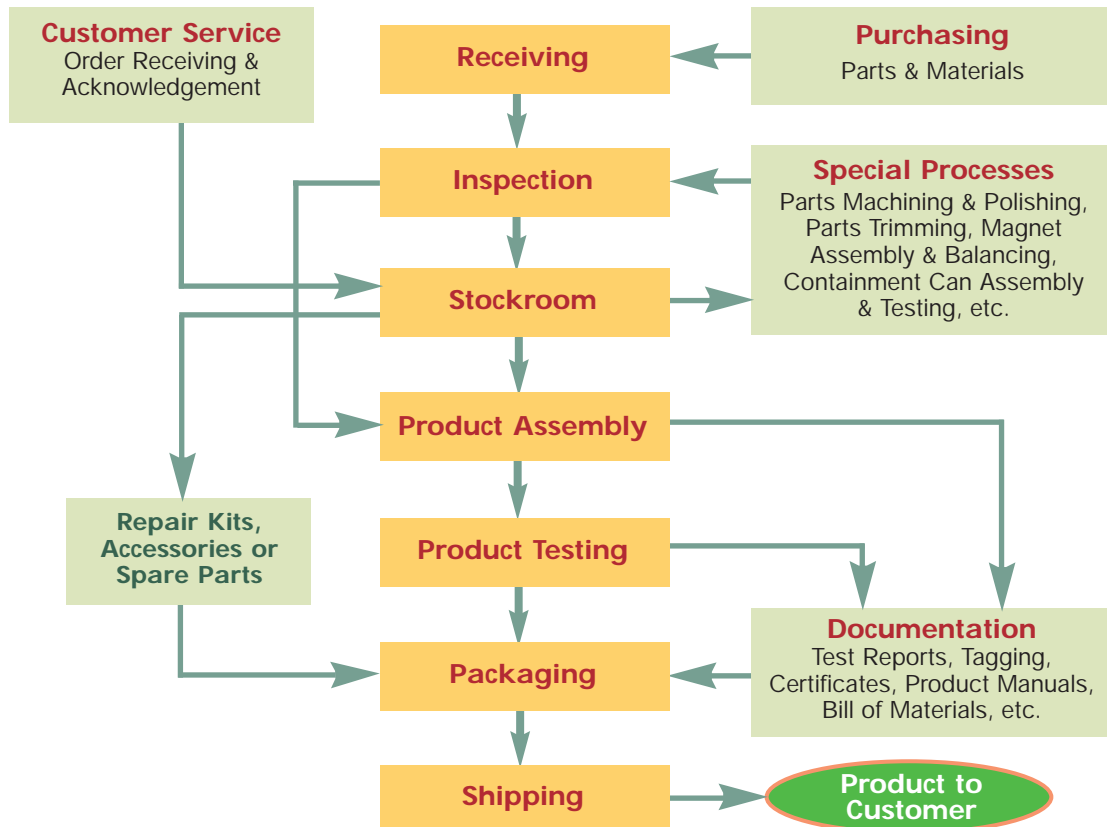

Good Manufacturing Practices = Good Products

Liquiflo's High-Quality Precision-Manufactured Pump Components

Liquiflo pump components are manufactured to the highest standards of quality by skilled machinists using high-grade materials and precision CNC machining centers, grinders, lathes, and milling machines. Here are some examples of Liquiflo's precision-made pump components:



Front Housing



Center Housing



Rear Housing

Precision-machined housings made to exacting tolerances are the backbone of every Liquiflo gear pump. Made from high-alloy materials, such as 316 Stainless Steel, Carpenter-20®, Hastelloy-C® or Titanium, these housings are designed to give years of service life even in the most corrosive of service environments.



Outer Magnet Assembly



Inner Magnet Assembly



Containment Can

Magnetic couplings are available with rare earth Samarium Cobalt magnets which provide both high torque and high temperature capability. Outer magnet casings are treated with a special epoxy coating to minimize corrosion from both moisture and chemical vapors. Inner Magnets are precision balanced and hermetically sealed by laser or TIG welding. They are 100% leak-tested to protect the magnets against corrosive fluids. Inner magnet casings match the metallurgy of the pump housing and are also available with PFA plastic coating for special applications.

Containment cans match the metallurgy of the pump housing and are 100% hydrostatically tested to ensure against leakage. Optional PFA-lined containment cans are available for increased protection against extremely aggressive or extremely hazardous chemicals.

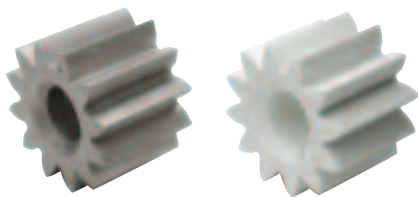

Gears

Gears (an obvious key element of our pumps) are available in a large selection of materials to optimize chemical resistance and wear properties, and to achieve the longest service life possible.



Wear Plates, Relieved

Liquiflo wear plates are manufactured with special cut-outs called relief grooves. These uniquely designed components increase pump life and performance by reducing intrinsic gear separation forces during pumping.

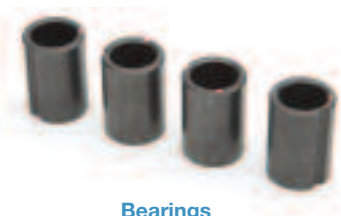

Bearings

Journal (or sleeve) bearings are a critical component of the gear pump and must be carefully chosen to maximize pump performance and longevity. Bearings are available in acid-grade Carbon 60, Silicon Carbide, PEEK and PTFE – to cover a wide range of applications.



Shafts

Liquiflo pumps are available with bare metal or special hard-coated shafts. Hard-coated shafts are extremely wear resistant (as much as 10 times more than 316 SS) and will substantially improve pump service life. Tungsten Carbide and Chrome Oxide shaft coatings are standard options for 316 SS and Alloy-C pumps.



Mechanical Seal Components

Only high-quality chemical duty mechanical seals are chosen for use in Liquiflo gear pumps. The standard and optimum seal component combination is a Carbon seal face vs. a Silicon Carbide seal seat. Other material combinations are available for special applications.

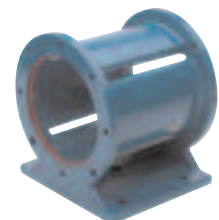

Pedestal

Pedestals are made of sturdy Cast Iron and epoxy-primed and painted to protect against corrosion. The pedestal is designed to support both the pump and C-face motor for close-coupled configurations.

Parts Inspection & Balancing

All Liquiflo parts – whether produced internally or from an external source – are carefully inspected for compliance with specifications before they are stocked, shipped or used to produce a final product. Over 70% of Liquiflo parts are produced internally.



Technician balancing inner magnet for a mag-drive pump: Precision balancing of internal components significantly extends the service life of our products.



Technicians measuring the dimensions of pump components with precision calipers: Liquiflo pump components are precisely manufactured to tolerances as low as .0004 inches (10 microns).

Product Assembly

Liquiflo pumps and products are assembled by trained technicians using documented standard operating procedures.



Technician assembling an outer magnet for a mag-drive pump: Liquiflo produces a variety of magnetic couplings to fit each pump model and match the torque transmission required by the application.



Technicians assembling a group of chiller circulation pumps for a large OEM: Whether it's a single pump order or a large pump order, Liquiflo is committed to completing each order accurately and on schedule.

Product Testing



All functional products – including pumps, replacement cartridges and relief valves – are performance-tested before shipping. Testing is performed in accordance with Hydraulic Institute standards.

Technician testing performance of a gear pump: Testing is conducted with water at room temperature. Each pump model must meet its specification for flow rate at various differential pressures.



Stockroom & Shipping

Quick deliveries is one of Liquiflo's major advantages. Liquiflo makes this possible by keeping a multi-million dollar inventory of over 100,000 individual parts comprised of over 3,000 unique part numbers. Over 90% of these parts can be shipped next-day. Standard pumps and products are typically shipped within 3 workdays.



Large order of gear pumps close-coupled to electric motors going to OEM factory: Liquiflo pumps are available with a large selection of ancillary options and accessories. These include flanged ports, relief valves, temperature control jackets, variable speed drives, gear reducers, air motors, base plate mounting and more.



Why Use Gear Pumps?

Gear Pumps are positive displacement pumps that are frequently used for metering, circulating and transferring both thin and viscous fluids at differential pressures higher than are typically achievable with centrifugal pumps.

Gear pumps can be considered a preferable alternative to Diaphragm pumps because they do not pulse or require an expensive air source to operate. For metering applications, Gear pumps, unlike Diaphragm pumps, do not require pulsation dampeners or other ancillary equipment. In continuous duty applications, Gear pumps generally last longer than Diaphragm, Progressive Cavity or Peristaltic pumps, which require frequent part replacements, such as diaphragms, stators, rotors or hoses.

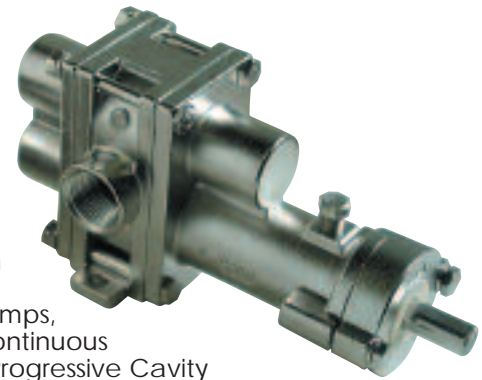

The excellent characteristics of gear pumps (wide range of flow and pressure, pulseless flow, small and compact design, long service life, ease of repair, etc.) have always made them a preferred choice of pumping methods. Originally, gear pumps were mainly used in applications for pumping higher viscosity fluids, such as oils, which have good lubricating properties for the internal components of the pump. However, Liquiflo extended the useful range of gear pumps down to the extremely low viscosity of 0.3 cP for the chemical industry. This achievement was accomplished by using gears made from self-lubricating engineered plastics, such as Teflon and PEEK, and developing special hardened Stainless Steel and Hastelloy-C shafts that further extend the service life of gear pumps even when used with viscosities as low as 0.3 cP.

Attributes & Advantages of Gear Pumps:

- Ideal for low-flow and high-pressure applications
- Virtually no pulsations – ideal for metering applications
- Flow accuracies of 0.5-2.0% are achievable
- Require less auxiliary equipment than Diaphragm pumps (pulsation dampeners, air compressors, dryers, etc.)
- No check valves to clog
- No diaphragms or hoses to rupture and leak
- Reliable – high MTBM (mean time between maintenance)
- Simple to understand and maintain – Repair kits are available which contain all components to completely and easily rebuild all Liquiflo gear pumps to like-new condition
- Self-priming/suction lift capability
- Low NPSHR – smaller pipe diameters are required
- Useful over wide range of viscosities (0.3 to 100,000+ cP)
- Bi-directional flow – interchangeable suction & discharge ports

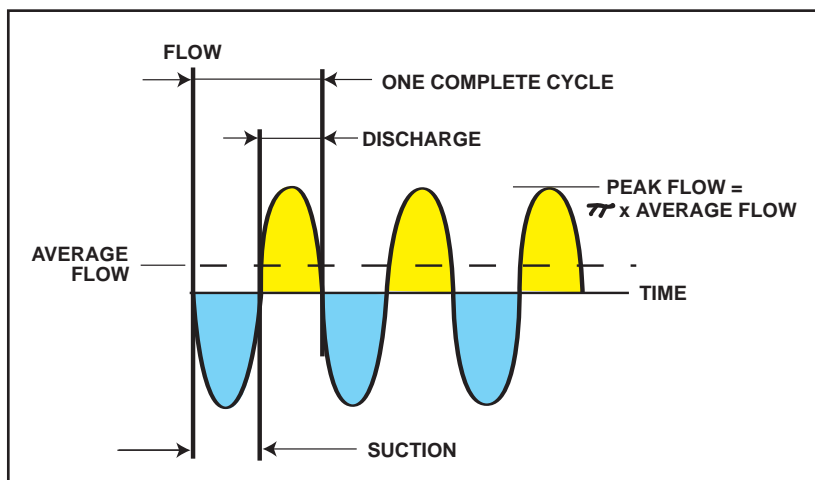

Upper (yellow) graph shows flow rate as function of time for a reciprocating diaphragm metering pump. The diaphragm pump produces large pulsations and high instantaneous flow rates. These pulsations are detrimental to precise metering and cause the diaphragm pump to require more suction pressure to operate effectively. Rotary gear pumps produce a smooth, pulseless flow (dashed line) and require less NPSH, making them ideal for metering applications.

Why Use Mag-drive (Sealless) Gear Pumps?

Magnetically-Coupled Pumps have no dynamic seals to leak or replace. Mag-drive pumps provide a simple and secure solution to sealing toxic, noxious, crystallizing or most other hazardous fluids.

Magnetically-coupled versions are available for all of Liquiflo's product lines, including the Centry® Series centrifugal pumps.



Mag-Drive Pumps:

- provide the simplest and best method for containing hazardous liquids
- are ideal for applications where absolutely no leakage can be tolerated
- are typically less expensive than double-sealed arrangements
- eliminate cooling loops required on double-sealed arrangements
- eliminate the need to dispose of barrier fluids used on double-sealed pumps
- require less maintenance than mechanically-sealed pumps since there are no seals to replace

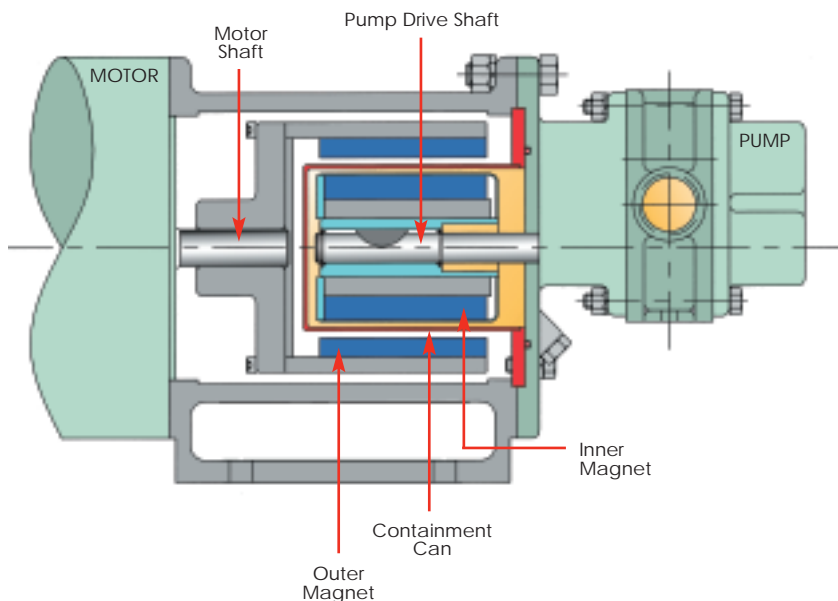
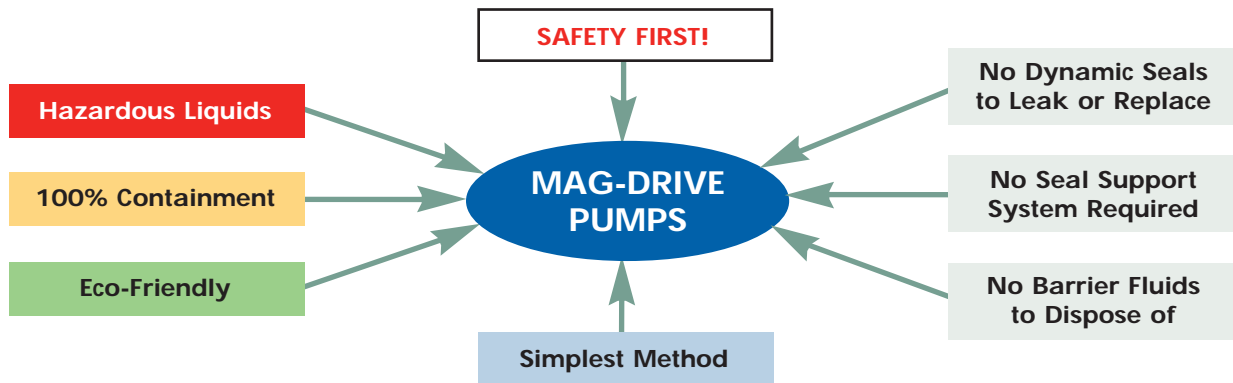

Mag-drive pumps transfer power from the motor shaft to the pump drive shaft via a magnetic coupling. The magnetic coupling consists of an outer magnet and inner magnet, matched in strength. The outer magnet attached to the motor shaft causes the inner magnet attached to the pump drive shaft to turn synchronously with the motor. Since the drive shaft is completely inside the pump housing, there is no need for a dynamic seal and the pumped liquid is completely contained.

Why Use Liquiflo Gear Pumps?

Liquiflo has been producing high quality gear pumps for the chemical industry for more than 35 years. With an extensive selection of corrosion-resistant and wear-resistant materials, sealing configurations and ancillary options, Liquiflo Gear Pumps can be custom engineered to handle a wide range of chemical pumping applications.

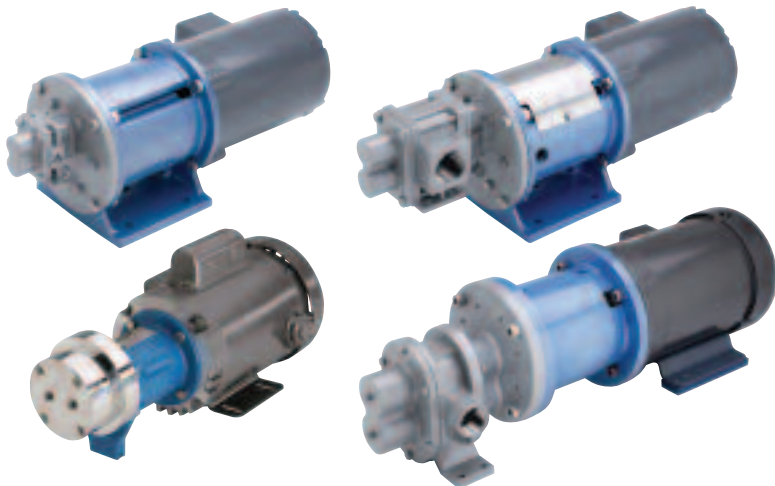

High-Viscosity Fluids

Water treatment polymers and food materials up to 80,000 cP are typical of the high-viscosity service of the H-Series gear pumps. When pumping high-viscosity materials, it is normally preferred to use larger size pumps running at slower speed to allow these thicker materials to enter the pump and fully fill the gear teeth cavities. Since slip is not a concern with high-viscosity fluids, gear outer diameters are usually trimmed to increase pump efficiencies. Running larger pumps at lower speeds have the additional benefit of extending pump life, decreasing pipe friction losses and reducing fluid shear.

High-Temperature Fluids

Solid or highly viscous chemicals at room temperature can be effectively pumped once they are heated to a more fluid state. Liquiflo offers several materials and ancillary options for this purpose. Liquiflo's pump selection process evaluates the effect of temperature on any nonmetallic components inside the pump. If necessary, these parts will be trimmed to ensure effective and efficient operation at the pumping temperature. The ancillary options include the Liquiflo Temperature Control Jacket, Dual Kan® and Power Frame. (See pages 22-23.)

Low-Viscosity Fluids

Liquiflo specializes in pumping low viscosity liquids using gear pumps. Since low viscosity fluids have little to no lubricity, Liquiflo uses gears made from carefully chosen engineered plastics such as PEEK or Teflon that have substantial self-lubricating properties as well as excellent wear and corrosion resistant properties. In addition, we use hard-coated shafts that exhibit extreme resistance to wear in the journal-bearing areas even when pumping extremely thin fluids. Liquiflo has pumped liquids with viscosities as low as 0.3 cP with impressive results. We have documented applications of pumps running in excess of 24,000 hours on 0.6 cP liquids.

Low-Temperature Fluids

Antifreeze, refrigerants or liquefied gases are typically pumped at temperatures below 20°C (i.e., room temperature). Liquiflo has successfully pumped cold or cryogenic liquids with mag-drive pumps using special-purpose materials and equipment. The Liquiflo Temperature Control Jacket and Dual Kan® are available for applications where low liquid temperatures must be precisely controlled. (See page 22.)

Metering

Liquiflo gear pumps are used in metering systems where the motor RPM is controlled to regulate pump output. Flow rate, pH levels or RPM can trigger the control of feedback signals. Liquiflo H-Series gear pumps are available in a wide variety of flow ranges (11 sizes offered), simplifying selection for metering applications. (See following page and the Engineering section, page 101, for more information on Metering.)

Crystallizing Fluids

Crystallizing fluids can be problematic for pumps with single mechanical seals. Fluids that crystallize when exposed to air can cause a crystal build-up around the edges of the seal faces, causing damage and premature seal failure. For this service, Liquiflo offers pumps with double mechanical seals or sealless magnetic drives. In both cases, the pumped fluid is isolated from the air, preventing crystallization. The double seal uses a pressurized barrier fluid system to contain the pumpage and flush the seal faces.

Hazardous Fluids

Toxic, noxious, flammable, corrosive or other dangerous liquids are best handled using sealless mag-drive pumps. These pumps have no dynamic seals and therefore completely contain the pumpage. Liquiflo was one of the first companies to apply magnetic-drive technology to gear pumps. Because of their simplicity, and importance to safety and the environment, all Liquiflo pump models are available in mag-drive configuration.

Metering

Gear pumps are often used in feedback-controlled metering systems because of their inherent pulseless flow as well as other inherent advantages. Feedback signals from flow meters, pH sensors, tachometers, level switches, etc., can control the motor speed and regulate the pump output. For example, an instantaneous flow meter signal can keep the flow rate constant despite changes in pressure, viscosity or temperature; the signal from a pH meter can vary the flow rate to control a process; or a totalizing flow meter signal can be used to send a specified volume of liquid to a process or tank and then automatically stop the motor.

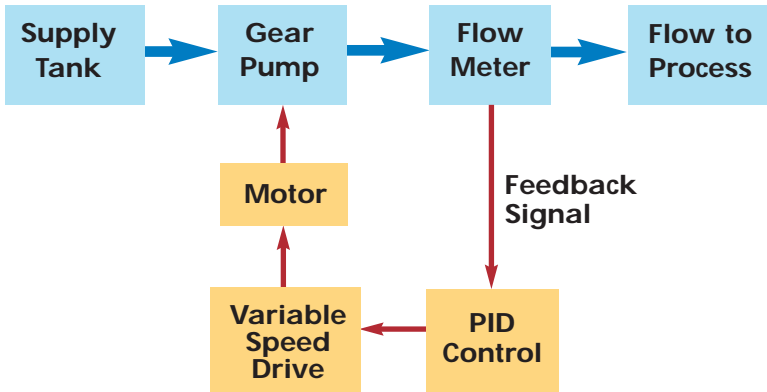

Circulation

Gear pumps are commonly used in applications where liquid needs to be circulated at a uniform rate to control temperature. Examples include cooling systems, such as chillers, air-conditioners and refrigeration units.

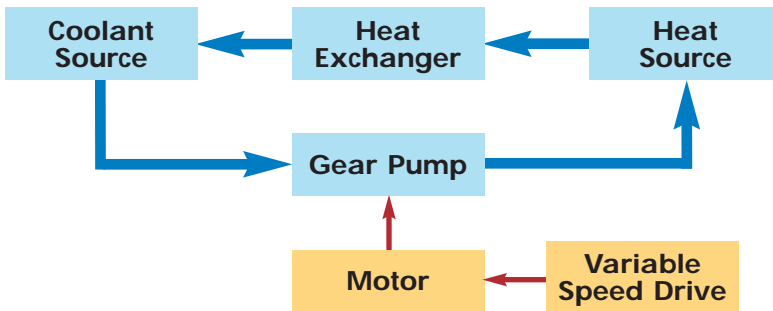

Transfer

Gear pumps are typically used in applications where liquid needs to be transferred from one location to another. Examples include loading liquids to vehicles for transportation, unloading liquids to storage tanks, pumping liquid from one tank to another, or filling a tank against gravity.

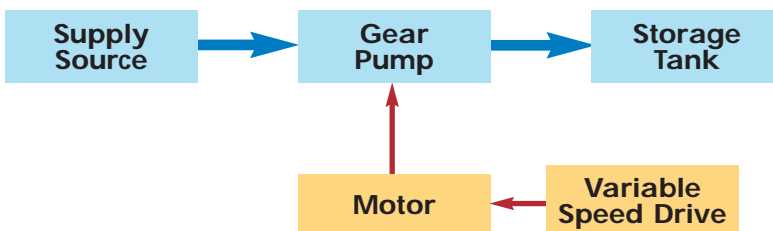

GENERAL PURPOSE GEAR PUMP FAMILIES: H-SERIES & 3-SERIES

The majority of low-to-medium flow chemical pumping applications (80-90%) can be handled with Liquiflo’s signature product lines: the H-Series and 3-Series Gear Pumps. These pumps cover flow rates (Q) up to approximately 55 GPM and differential pressures (ΔP) up to 225 PSI (see graph below).

H-Series: Heavy Duty Industrial Gear Pump

The H-Series Gear Pumps were designed as an upgrade to Liquiflo’s original 3-Series. With similar outside dimensions and capacities, the H-Series incorporates larger diameter shafts and bearings, allowing them to handle higher pressures with extended service life. The H-Series pumps are available in 316 Stainless Steel or Alloy-C construction, and Sealed and Mag-drive versions with flows up to approximately 30 GPM and differential pressures up to 225 PSI with 300 PSI possible on some models.

The H-Series is Liquiflo’s most popular and versatile Gear Pump line, and is recommended for all new applications as well as an upgrade to any existing 3-Series installations.

Performance Range of H-Series & 3-Series Gear Pump Families

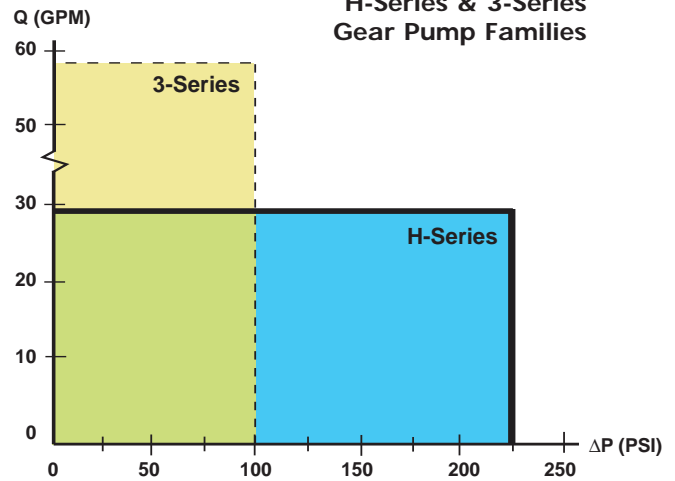

3-Series: Standard Duty Gear Pump

Liquiflo’s original 3-Series Gear Pumps are available in Sealed and Mag-Drive versions with flows up to approximately 55 GPM and differential pressures up to 100 PSI.

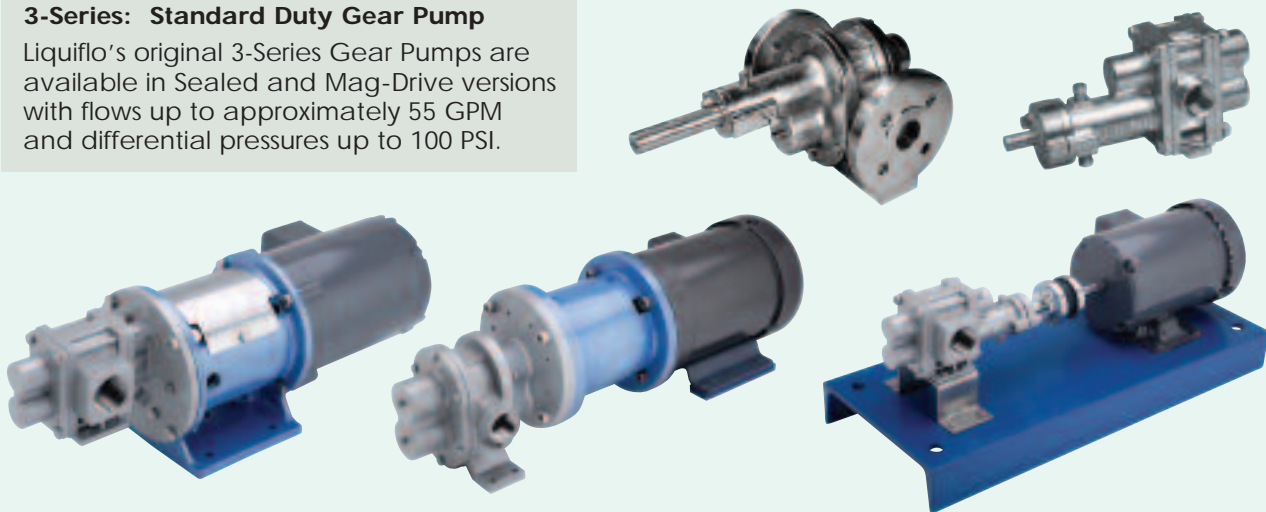

H-SERIES & 3-SERIES Available Materials of Construction

HOUSINGS	GEARS	WEAR PLATES	BEARINGS	SHAFTS
316 SS	316 SS	Carbon 60	Carbon 60	316 SS
Alloy-C	Alloy-C	Silicon Carbide	Silicon Carbide	Alloy-C
Alloy-20 ¹	PEEK	PEEK	PEEK	TC-Coated
	Ryton	Teflon ²	Teflon ²	CO-Coated
	Teflon ²			
	Carbon ¹			
	Delrin ¹			

(1) Available in 3-Series only. (Delrin gears are available for repair or replacement only.)

(2) 25% Glass-filled PTFE.

(3) For available seal materials, see page 19.

Note: For additional information on the above materials, refer to the Engineering section, pages 132-135.

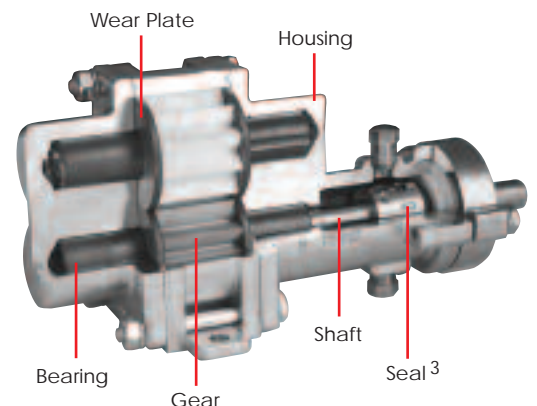

SPECIAL PURPOSE GEAR PUMP FAMILIES

2-Series, 4-Series & Max®-Series Gear Pumps

For applications involving ultra low flows, compact chemical metering systems or higher differential pressures, Liquiflo offers several special purpose gear pump families. (These pump families are described below.) The performance range of the special purpose pump families, relative to the H-Series, is shown at right.

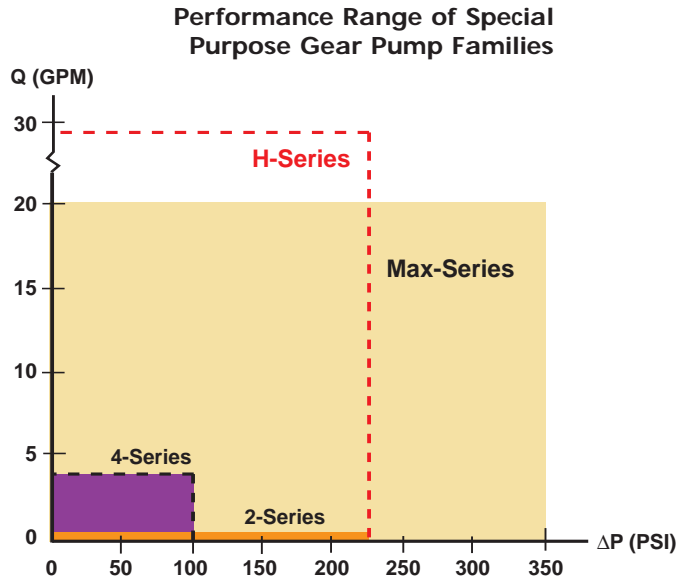

2-Series: Ultra Low-Flow Gear Pump

The 2-Series Mag-Drive Gear Pumps were designed for low-flow applications. Their compact and rugged design makes them ideal for many applications, including chemical dosing and metering, pipeline sampling and wastewater treatment. The 2-Series pumps are available in corrosion-resistant 316 SS construction and deliver flows up to approximately 30 GPH (0.5 GPM) at differential pressures up to 225 PSI.



4-Series: Low-Flow Gear Pump

The 4-Series Mag-Drive Gear Pumps were designed for OEM applications such as chemical feed systems. These pumps offer a large selection of materials to cover a wide variety of chemical processing applications. A unique feature of the 4-Series pump is its parallel port connections located on the front of the pump. The 4-Series pumps are available in 316 SS, Alloy-C or Titanium construction and deliver flows up to 3.5 GPM at differential pressures up to 100 PSI.



Max®-Series: High-Pressure Gear Pump

The Max-Series pumps feature helical gears and relieved wear plates for smoother and quieter operation and intrinsic reduction of gear separation forces. Their unique and durable design will assure extended life in high-pressure pumping applications. The Max-Series pumps are available in Sealed and Mag-Drive versions with flows up to 20 GPM and differential pressures up to 350 PSI. The basic material of construction is 316 SS with Titanium available for select models.



Note: See following page for more information on the Max-Series Pumps.

Note: For more information on the available materials for the pump families listed above, refer to the Engineering section, pages 132-135.

Max®-Series High-Pressure Gear Pump

FEATURES

The Liquiflo **Max-Series** Gear Pumps will handle differential pressures to 350 PSI and flows to 20 GPM. Their unique, durable design assures extended life even in high-pressure pumping applications where other gear pumps could fail. The Max-Series pumps feature Helical Gears and Relieved Wear Plates for smoother and quieter operation.

- Flows up to 20 GPM
- Pressures up to 350 PSI
- Sealed or Mag-Drive
- 316 SS or Titanium Construction
- Threaded or Flanged Ports
- Available in 9 sizes
- Close-Coupled
- Temperature Control Jackets available

Heavy-Duty Construction

Solid 316 SS or Titanium Body

The **Max-Series** heavy duty shaft and bearing design make it last even when operating at high differential pressures for extended lengths of time. Its solid construction and oversized heavy duty bolts will minimize pump distortion caused by piping misalignment. The pump mounting bracket is made of corrosion resistant 316 SS or sturdy Cast Iron.

Configurations

Mechanical Seal or Mag-Drive, Close-Coupled

The **Max-Series** pumps are available in either single or double mechanical seal or mag-drive configurations. The universal seal housing will accommodate either a single or double mechanical seal. The close-coupled design eliminates difficulties and inconveniences of manually aligning the pump and motor. Max pumps are offered in 316 Stainless Steel or Titanium housings with a variety of internal component materials to optimize your selection for specific chemical applications.

Applications for Corrosive Chemicals

Liquiflo **Max-Series** Gear Pumps were designed to handle a variety of chemical processing applications including the metering and transfer of extremely corrosive and toxic chemicals. The Max is available in several choices of corrosion resistant materials including 316 SS and Titanium to optimize longevity and long-term reliability. Liquiflo's highly experienced application engineers can assist you in optimizing the correct choice of materials to suit your specific chemical pumping applications.

17-4 PH SS Integral Gear-Shaft Arrangement

Sealed **Max-Series** pumps are available with an integral gear-shaft arrangement made of 17-4 PH SS (precipitate hardened stainless steel). By using a heat-treated metal-to-metal gear configuration, higher pressures can be achieved without the risk of galling or accelerated wear. 17-4 PH SS materials are only recommended for moderately aggressive chemicals, and metal-to-metal gears should only be applied when pumping liquids with viscosities of at least 100 cP. Contact factory for specific applications.



Close-coupled
Mag-Drive: Models M0-M8
Sealed: Models M5-M8

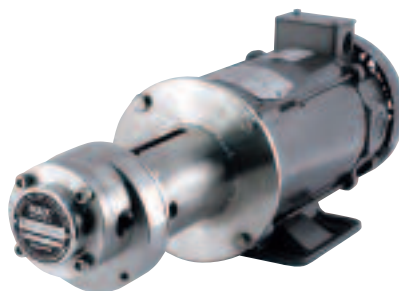

Close-coupled
Sealed: Models M0-M4



HELICAL GEARS

The Liquiflo Max-Series Gear Pump features Helical Gears for both smoother and quieter operation, and longer bearing life due to intrinsic reduction of gear separation forces.

Note: For more information on the Max-Series Gear Pumps, see pages 66-77.

Introducing the PFA-Lined Gear Pump

NEW PRODUCT

Typical Uses and Applications

Liquiflo's **PFA-Lined Gear Pump** is an excellent choice for inorganic acids, bases and salts, that are difficult to handle with or require expensive alloys in metallic pumps, such as: Hydrochloric Acid, Ferric Chloride, Sulfuric Acid, Hydrofluoric Acid, Sodium Hypochlorite, Nitric Acid, Sodium Hydroxide and Chromic Acid to name a few. Another key application area is for high purity services where contact with metallic components must be avoided.



Features:

- PFA-Lined Stainless Steel Housings
- SiC Shafts & Bearings
- PFA-Lined Containment Can
- Flows up to 15 GPM
- Pressures up to 100 PSI
- Temperatures to 200°F
- Available in both DIN & ANSI flanged connections
- Currently available in 7 sizes

No Wetted Metal Components

- PFA-Lined pressure boundary components
- PFA-Encapsulated Inner Magnet
- Self-Sintered Silicon Carbide (SiC) Shafts
- Self-Sintered Silicon Carbide Bearings & Wear Plates
- PEEK, Ryton or Teflon Gears

MATERIALS AVAILABLE

HOUSINGS	GEARS	WEAR PLATES	BEARINGS	SHAFTS
SS-PFA Lined	PEEK Ryton Teflon	Silicon Carbide*	Silicon Carbide*	Silicon Carbide

* Other materials are available; contact factory.

Note: For further information on the above materials, see the Engineering section, pages 132-135.

Advantages of PFA-Lined Stainless Steel Housings

- Traditional pressure integrity expected of metal pumps
- Exempt from wicking problems associated with fiber reinforced housings
- Limits the effects of heat entrapment and corresponding thermal expansion issues
- Limits the effects of fluid absorption
- Increases strength and durability required for process pump services

Benefits of SiC Shafts & Bearings

- Exceptional chemical resistance
- Exceptional wear resistance

PFA-Lined Containment Cans

- Alloy-C containment can limits eddy current development and subsequent heat generation
- PFA-lined carbon fiber containment can eliminates eddy currents altogether

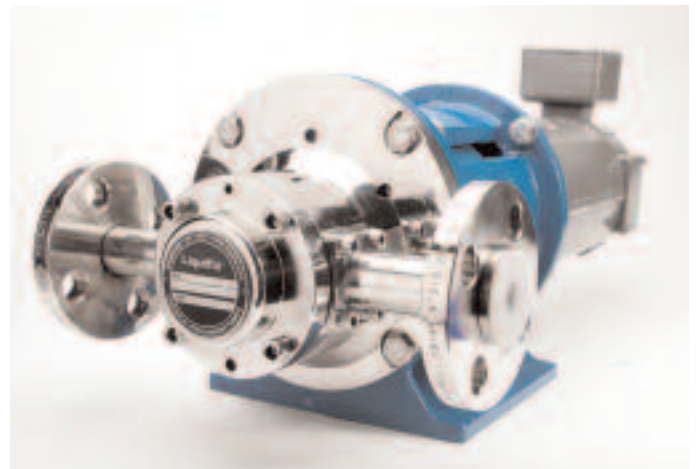

Pump Model	P1	P2	P3	P4	P5	P6	P7
Gear Width (inches)	0.375	0.625	0.875	1.312	1.000	1.375	1.750
Flow (GPM) @ 1750 RPM	1.4	2.4	3.4	5.0	8.6	11.8	15.0

Note: For further information about the PFA-Lined Gear Pump, please contact the factory.

Wear Resistant Materials: Hard-Coated Shafts & Silicon Carbide Bearings

Liquiflo uses a selection of three standard materials, 316 SS, Alloy-C and Titanium, for making pump housings and shafts. These materials are unquestionably the best materials available in the market today and are obviously chosen for their excellent corrosion resistant properties. Unfortunately, none of these extremely corrosion resistant materials can be hardened by the conventional means of heat treatment and therefore only offer limited wear resistant properties. In particular, the areas of the shaft that contact the bearings (journal-bearing regions) are the only areas of the shaft that are subject to wear. The wear rate of the shaft is highly dependent on the viscosity of the fluid being pumped (thin fluids have less lubricating properties), and the operating speed and pressure. Shaft wear is often the limiting factor on the life cycle of the pump. By using a very specialized process, which we refer to as Hard Coating, Liquiflo can manufacture shafts with outstanding wear resistant properties in the critical journal-bearing areas while maintaining the excellent corrosion properties of 316 SS, Alloy-C or Titanium. This innovation can add as much as a 10-fold increase to the life of the pump. The dramatic improvement in pump life that Hard Coating offers is especially evident when pumping thin fluids, which have little to no lubricating properties.

Hard-Coated Shafts:

Liquiflo manufactures standard pump shafts using precision CNC machines. Hard-coated shafts are produced by the following method:

- 1) Standard metal shaft, made from relatively soft 316 SS, Alloy-C or Titanium. (Although these materials are extremely corrosion resistant, they lack substantial wear resistant properties in the journal-bearing regions – the critical areas where contact and wear often occurs.)

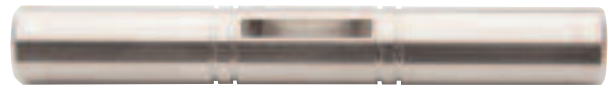

1. Bare Metal Shaft

- 2) Shaft is undercut approximately .010" in the areas of bearing engagement to allow for wear-resistant coating material.



2. Undercut Shaft

- 3) Shaft is plasma spray-coated with both intense heat and pressure, causing the carbide or oxide coating material to fuse with the base metal surface of the shaft. (These coating materials are extremely hard – close to that of diamond – and therefore are extremely wear resistant.)



3a. Plasma Spray Coating



3b. Rough Coated Shaft

- 4) The coated shaft is now diamond ground and polished to obtain the precise diametral tolerance and ultra-smooth surface finish, which allows for optimal *fluid film lubrication* during operation.



4a. Diamond Grinding



4b. Polishing

- 5) The finished coated shaft now has excellent wear resistant properties in the journal-bearing areas due to the hard coating process, and the base material of the shaft maintains the desired chemical resistance.



5. Finished Coated Shaft

Wear Resistant Materials: Hard-Coated Shafts & Silicon Carbide Bearings

Liquiflo 316 SS and Alloy-C shafts are available with Tungsten Carbide or Chrome Oxide coating. Titanium shafts come standard with Titanium Oxide coating. These materials allow for a wide range of chemical, physical and thermal compatibility.



Tungsten Carbide (TC) Coated Shaft

TC-coated shafts are the primary choice when hardened shafts are required. The Tungsten Carbide coating is extremely hard and compatible with a wide range of chemicals, and can be used for high-temperature applications. One important application where TC-coated shafts cannot be used is for hydrogen peroxide (H_2O_2), due to a catalytic reaction with the coating's nickel binder. For this case, CO-coated shafts should be used.



Chrome Oxide (CO) Coated Shaft

CO-coated shafts are also compatible with a wide range of chemicals (including H_2O_2) but the Chrome Oxide coating is slightly softer than Tungsten Carbide. Due to the very low thermal expansion of the ceramic CO coating, the application temperature must be limited to 250°F for this shaft material.

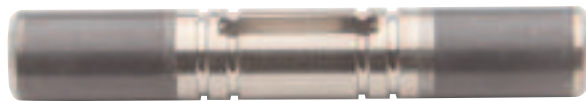

Titanium Oxide (TO) Coated Shaft

TO-coated Titanium is the standard shaft material for Liquiflo Titanium pumps. Common applications include sodium hypochlorite ($NaOCl$) and aqueous ferric chloride ($FeCl_3$). Due to the very low thermal expansion of the ceramic Titanium Oxide coating, the application temperature must be limited to 250°F.

Note: For more information about coated shafts (and uncoated shafts), refer to the Engineering section, page 135.

Silicon Carbide Bearings:

Silicon Carbide (SiC) is one of the hardest synthetic materials known, having a Mohs hardness value of approximately 9.0 (diamond is the highest at 10). Consequently, special diamond tools are required to machine it. Liquiflo pumps use self-sintered SiC bearings, which offer excellent abrasion and chemical resistance. Due to the extreme hardness of the material, Liquiflo SiC bearings have a slip-fit design to facilitate installation and removal of the bearings from the pump housings. SiC bearings are used in conjunction with hard-coated shafts to provide a highly effective wear-resistant material combination.

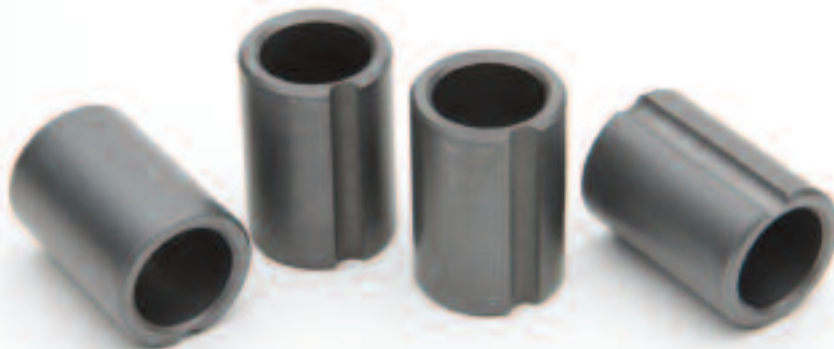

Pure Self-Sintered
Silicon Carbide (SiC) Bearings

TC-Coated Shafts vs. SiC Bearings:

Tungsten Carbide coated shafts running against Silicon Carbide bearings provide superior wear resistance in difficult pumping applications. Liquiflo pumps constructed with this material combination have seen lifetimes in excess of 50,000 hours (over 5 years) of continuous operation!

Note: For guidelines on bearing and shaft material selection, and more information on fluid film lubrication, refer to the Engineering section, pages 136-137.

Close-Coupled Configuration

Misaligned pumps add excess radial loads and stresses to shafts, bearings and seals. This is one of the most common causes of premature pump failure. The close-coupled configuration prevents misalignment and eliminates the need to manually align the pump and motor. Simply bolt the pump and motor to the pedestal and exact alignment is guaranteed. Installation and maintenance of the pump and motor are greatly simplified and the maintenance issues associated with misalignment are eliminated.

Features of Close-Coupled Design:

- Eliminates manual alignment of pump and motor
- Simplifies installation and maintenance
- Extends pump life by preventing misalignment
- Includes Cast Iron pedestal that rigidly supports pump and motor
- Sealed and Mag-drive pumps are dimensionally interchangeable
- Compatible with NEMA and IEC C-face motors
- Installation is quick and easy

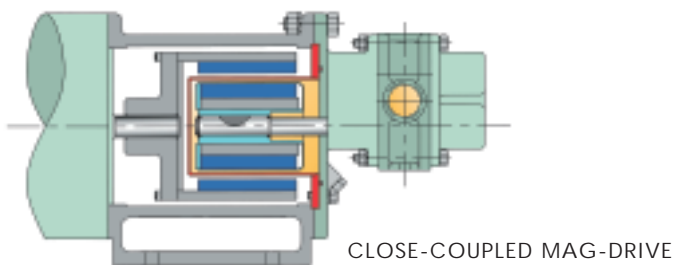
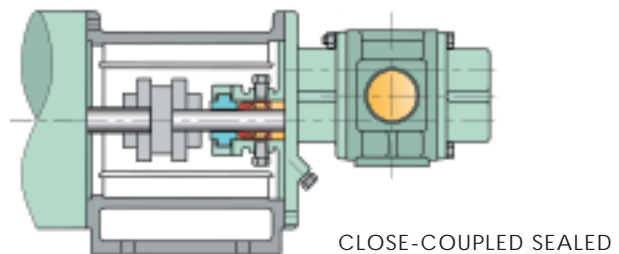
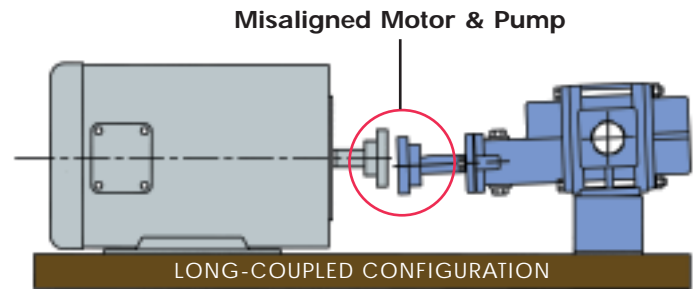

Sealed Pumps – Close-Coupled

The close-coupled configuration is the most common arrangement for sealed pumps. It makes installation easy by eliminating the need to align the pump shaft to the motor shaft in the field. Perfect pump-motor alignment and positioning is guaranteed by the precision-machined mounting bracket. Close-coupled sealed pumps include a Cast Iron mounting bracket and flexible drive coupling ready to mate to a motor of your choice. The removable door on the mounting bracket allows for easy accessibility to the coupling or seal area of pump for servicing or seal replacement. These pumps can also be furnished from the factory with any type of motor, variable speed drive or gear reducer.



Magnetic Drive Pumps

The Mag-drive pump is the ultimate method for handling hazardous liquids since it eliminates the need for dynamic seals, which are the most common source of leaks in standard sealed pumps. Mag-drive pumps come standard in close-coupled configuration with mounting bracket and outer magnet that will attach to the motor frame size specified when ordering. These pumps can also be furnished from the factory with any type of motor, variable speed drive or gear reducer.



Liquiflo's **Universal Front Housings** will accommodate packing as well as single and double mechanical seal configurations.

RANGE OF SEALS AVAILABLE

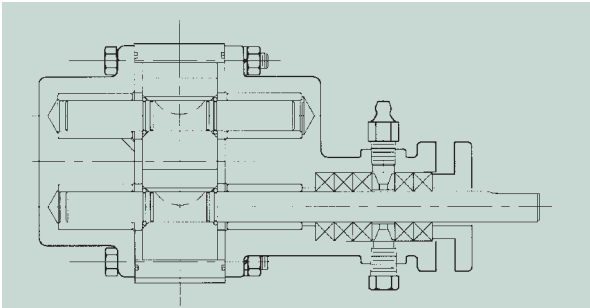

FIG.1 PACKING SEAL

Fig. 1 Packing is the simplest and most economical solution for pumping non-hazardous liquids where minor leakage is acceptable. Braided Teflon packing is the primary choice for applications up to 350°F. Graphoil packing is available for high-temperature applications up to 500°F.

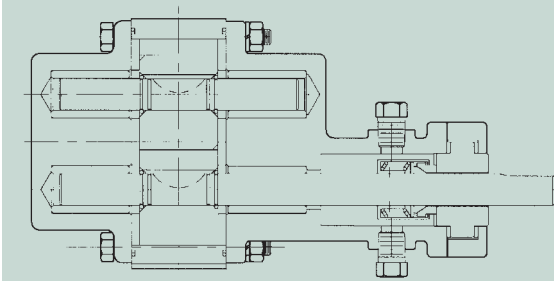

FIG.2 SINGLE MECHANICAL SEAL

Fig. 2 Single Mechanical Seals are the most common seal type used for chemical applications and are used when leakage needs to be minimized. With the right combination of materials, they can be applied for high-pressure, high-temperature and light-abrasive service. Single seals have a viscosity limit of 5,000 cP and a temperature limit of 500°F.

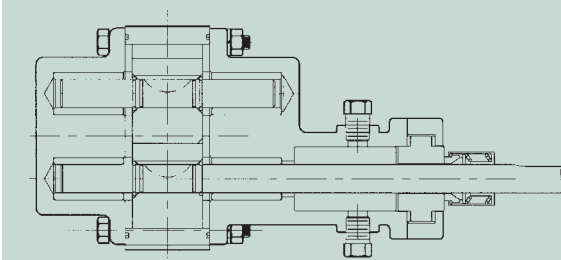

FIG.3 EXTERNAL MECHANICAL SEAL

Fig. 3 External Mechanical Seals are used to isolate the seal body from the pumpage or when pumping liquids under vacuum conditions. These seals can sometimes be replaced without disassembling the pump. External seals have the same viscosity and temperature limitations as single internal seals and are not as effective when operating at pressures above atmospheric.

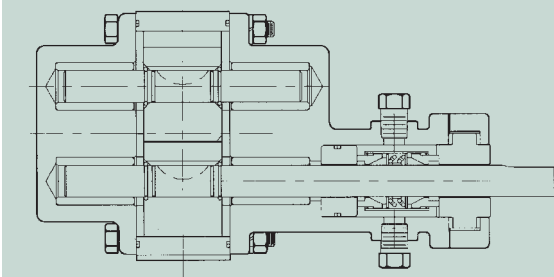
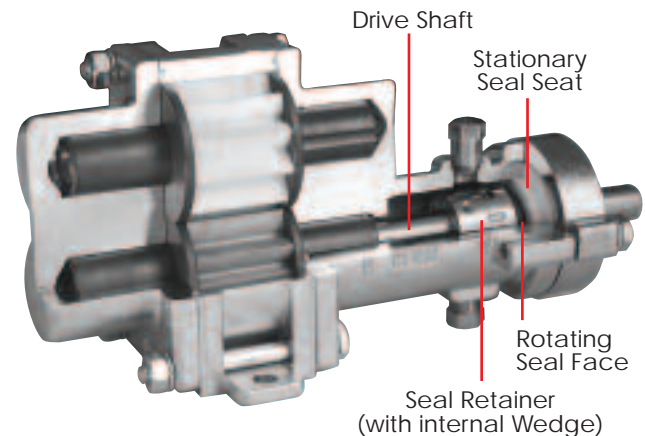

FIG.4 DOUBLE MECHANICAL SEAL

Fig. 4 Double Mechanical Seals require a pressurized flushing system and are typically used when pumping liquids that are viscous, slightly abrasive, crystallize on contact with air or are very hazardous. Double seals will completely contain the pumpage provided that they are properly supported by the flushing system.

SEAL MATERIALS AVAILABLE

PACKING	SEAL WEDGES	SEAL FACES	SEAL SEATS
Braided Teflon Graphoil	Teflon Graphoil	Carbon Silicon Carbide Teflon	Silicon Carbide



Cutaway view of Sealed Gear Pump showing components of Single Internal Mechanical Seal

Note: For more details on seal construction, refer to the Engineering section, pages 96-100.

Liquiflo pumps are easy to maintain or repair. Full-color installation and maintenance manuals are available that give clear, step-by-step instructions for disassembling and rebuilding the pumps. All manuals are available on the Liquiflo website and are also included with each pump, replacement cartridge or repair kit shipment. When pump maintenance or repair is necessary, the following options are available:

Maintenance & Repair Options:

- A) **Replace Pump** – required when pump housings are worn to a point where acceptable performance cannot be restored by rebuilding pump with a repair kit or spare parts
- B) **Use Replacement Cartridge** – this is the fastest way to replace a mag-drive pump that requires maintenance (see next page)
- C) **Use Repair Kit** – if the housings are in good shape, pump performance can be restored to like-new condition by replacing the pump’s internal components (kits available for gear pumps only)
- D) **Replace Individual Parts** – all Liquiflo pump components can be purchased separately

Liquiflo Repair Kits contain all components to completely rebuild your Liquiflo Gear Pump to like-new condition

Repair Kits are available for all Liquiflo Gear Pump Families



Why Use Repair Kits?

- Repair Kits simplify inventory and speed repair
- Repair Kits include gears and shafts pre-assembled
- Repair Kits ensure that all wear items in the pump will be replaced
- Repair Kits encourage replacement of non-reusable items such as O-rings and Retaining Rings
- Repair Kits allow pumps to be immediately rebuilt should a performance problem occur
- Repair Kits are a more efficient and cost-effective solution than using individual parts

How to Order Liquiflo Repair Kits:

Simply place a “K” in front of the Liquiflo Pump Model Number.

Example: Sealed Pump & Kit

Pump Model #: H5FS6PEEU000009

Kit Model #: KH5FS6PEEU000009

REPAIR KIT CONTENTS

- Gears
- Shafts
- Keys
- Bearings
- Wear Plates
- Pins
- O-Rings
- Retaining Rings
- Seals (if applicable)

Liquiflo Replacement Cartridge – The fastest way to replace a pump

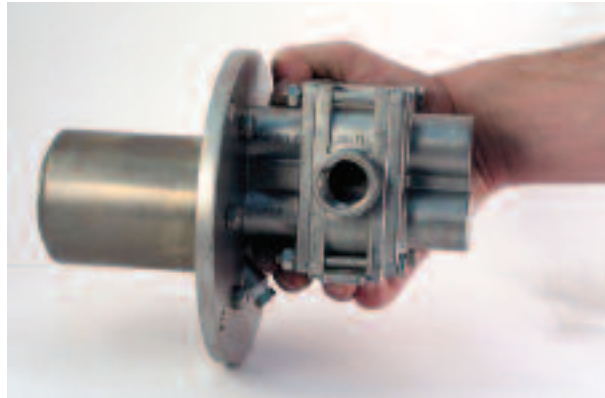

Cartridges are available for H-Series & 3-Series Mag-drive Gear Pumps

How to Order Liquiflo Cartridges:

Pump Cartridges are available from the factory fully assembled. To order, simply place a "C" in front of the Liquiflo Pump Model Number.

Example: Mag-drive Pump & Cartridge

Pump Model #: H5FS6PEE100000US

Cartridge Model #: CH5FS6PEE100000US

Why Use Pump Cartridges?

- Pump Cartridges are easier, faster and more economical to replace than the entire mag-drive pump
- A Cartridge replacement keeps the process running without long repair time interruption
- A Cartridge replaces the entire wet end of a mag-drive pump in minutes, without having to diagnose and analyze the cause of failure
- A Cartridge restores pump to 100% performance
- Once the system is up and running, the removed Cartridge can be repaired with a Repair Kit at your convenience (provided housings are in good condition)
- The repaired Cartridge will be ready to serve as the next replacement Cartridge when the pump requires maintenance

Five Simple Steps for Immediate Pump Replacement:

- 1 Disconnect piping
- 2 Remove four bolts and the Pump Cartridge
- 3 Slip in the new Cartridge and replace bolts
- 4 Reconnect piping
- 5 Continue pumping



A **Cartridge** is a complete Mag-drive pump less the outer magnet and pedestal

PORT CONNECTIONS

Threaded Ports

All Liquiflo pumps are available with NPT or BSPT ports.

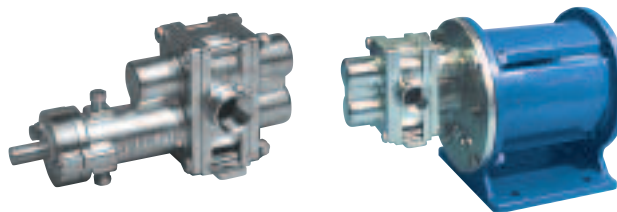

Raised-Face (RF) Flanges

Most Liquiflo pumps are available with flanged ports to simplify piping connections. Available flanges are ANSI 150# or 300#, DIN PN16 and JIS 10K.

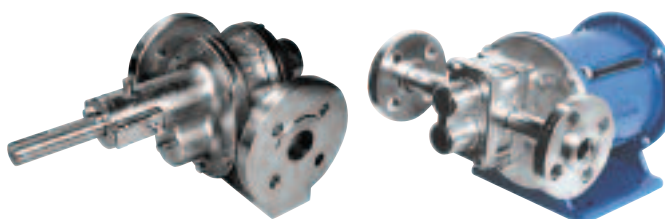

Sanitary Fittings

Tri-clamp sanitary fittings provide a convenient alternative to threaded or flanged port connections.

Note: Available only for specific pump sizes. Consult Factory.

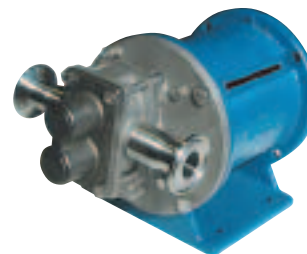

TEMPERATURE CONTROL

Temperature Control (Heat) Jackets (Clamp-on Design)

Liquiflo's Temperature Control Jacket can maintain the pump at either elevated or reduced temperatures. It is commonly used when pumping liquids that solidify or become difficult to pump when the temperature decreases. The jacket body is made of Cast Aluminum; the connectors are made of Stainless Steel.



Dual Kan® (Double Wall Containment Can)

Liquiflo's patented Dual Kan® controls the temperature of the back end of a magnetically-driven pump by circulating a heating or cooling fluid through the containment can. This is ideal for applications requiring precise and uniform temperature control. The Dual Kan® will compensate for increases in temperature due to eddy current losses from the mag-drive coupling. (See Engineering section, page 92.)



COUPLING & MOUNTING

S-Adapter

The S-Adapter is used with the Liquiflo MC-Pedestal to long-couple mag-drive pumps. It isolates the pump from the motor and can be used when long-coupling motors or drives that do not have a C-face mounting. The maximum temperature rating is 250°F (~120°C).

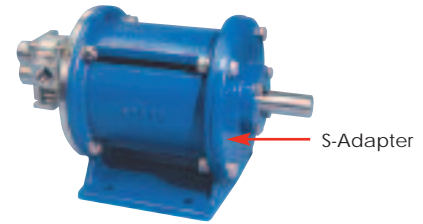

Power Frame

The Liquiflo Power Frame is used to long-couple mag-drive gear pumps or the Centry® Series centrifugal pumps, for use in high-temperature applications – up to the pump’s maximum temperature rating. Its integral cooling jacket keeps the bearing system of the pedestal cool even when it is coupled to a pump operating at extremely high temperature.

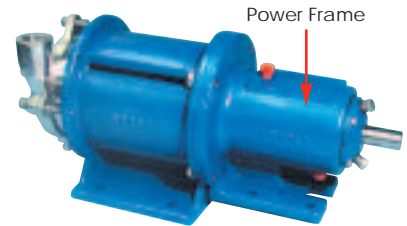

Base Plate Mounting

Most Liquiflo pumps are available with base-mounts to simplify installation. Liquiflo also offers base-mounted units with or without the motor pre-installed. Stainless Steel and Epoxy-painted Channel Steel base plates are available.

Note: For more details on Coupling & Mounting, see the Engineering section, page 94.

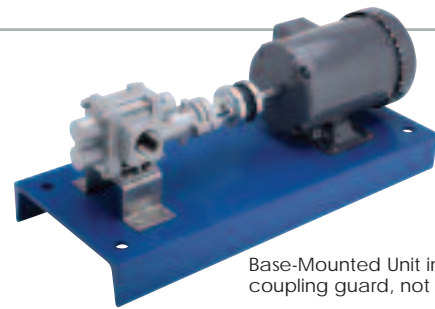

Base-Mounted Unit includes coupling guard, not shown.

RELIEF VALVES

Positive displacement pumps should be installed with a Relief Valve in the discharge line to protect the pump and piping from any type of line blockage, including the inadvertent closing of an isolation valve. Liquiflo manufactures two sizes of relief valves in both 316 SS and Alloy-C. (See Engineering section, page 95, for more details.)



ACCESSORIES

Mechanical couplings, coupling guards, risers, base plates, adapters, brackets and pedestals, can all be purchased separately.

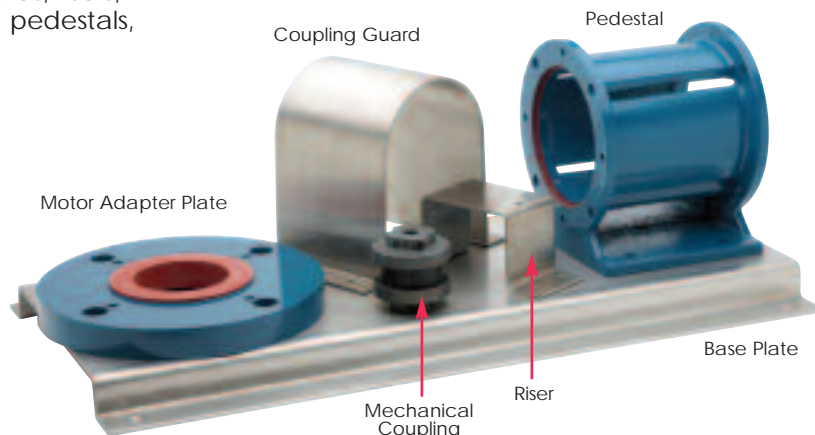

MISCELLANEOUS OPTIONS

Liquiflo Gear Pumps can be furnished from the factory with any type of motor, variable speed drive or gear reducer.

Application Case Histories for Liquiflo Gear Pumps

There's only one true test of pump performance: The Field Test

The following case histories (in alphabetical order) attest to the versatility and dependability of Liquiflo gear pumps in some of the most difficult and challenging field applications. When you absolutely have to depend on a pump, isn't it good to know that you can rely on the kind of performance that Liquiflo pumps delivered in these cases?

Carbon-13 Extraction

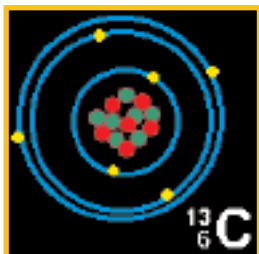

Carbon-13, a stable isotope often called "the Gold Sample" is used in medical, biological, agricultural and environmental industries. With a value of about \$700 per gram, carbon-13 is extracted in a complicated and difficult operation that requires carefully controlled chemical reaction and condensation processes. This poses a particular challenge to the pumps that must continually circulate the process liquids at stable, precisely controlled rates.

A carbon-13 plant constructed in China evaluated centrifugal, diaphragm and locally produced gear pumps. None could provide the system control or reliability required – but Liquiflo could. The facility specified 20 sets of Liquiflo gear pumps, equipped with frequency converters to accurately control flow rates. The chief engineer of the plant compared these Liquiflo pumps to a human heart in terms of their function and importance to the operation. The pumps have operated for years without a single failure, and their ability to deliver precise, pulse-free pumping rates has allowed the entire plant to operate at high efficiency.

Caustic Corrosives for Paper Mills

Paper mills have traditionally been a graveyard for pumps. The combination of high temperatures, highly caustic pumpage, high flow demands and ceaseless around-the-clock operation will quickly expose the weak points of any pump.



One of the most demanding mill applications was found in Germany. A single pump had to handle both a 50% solution of corrosive sodium hydroxide (NaOH) and a highly corrosive bleaching compound, at pressures over 5 bar. The pump had to ensure transfer down a ring pipe that was nearly a quarter-mile long – and the pump had to operate at high efficiency.



Not surprisingly, the pump chosen was a Liquiflo gear pump. With available high corrosion-resistant constructions, the pump could be specified to handle the harsh chemicals. Sealless design meant leak-free operation and the inherent efficiency of the Liquiflo gear pump design over its closest competitor – a centrifugal pump – made the Liquiflo pump a far more cost-effective choice.



Application Case Histories for Liquiflo Gear Pumps

Chemical Metering for Water Purification Plants



The Metropolitan Water District of Southern California is the largest water system in the world, responsible for providing billions of gallons of safe, potable water to tens of millions of people.

Over the past twenty years, the Water District has tried a variety of chemical metering pumps – and found that all had limitations. Diaphragm pumps and progressive cavity pumps turned out to be maintenance-intensive, with a high cost of ownership. Many types of gear pumps were tried – but they lacked the necessary accuracy and had high wear rates.

Then, in the early 1990’s, the District tried its first Liquiflo sealless mag-drive gear pumps. Even with variable speed drives and special motor engineering, the Liquiflo pumps were about half the price of the pumps they replaced. The performance of this combination has been so exceptional that the District has replaced over 124 of its previous pumps with this Liquiflo design.

Fumigants & Pesticides

A leading US manufacturer of agricultural fumigants and pesticides had a problem with their current pumps. They suffered from accelerated internal wear and early failure that was costing thousands of dollars per month in replacements and downtime.

Their pump representative suggested a switch over to the Liquiflo H-Series gear pumps with a superior selection of internal components than the current pumps, which gave the Liquiflo pumps a much broader reach of chemical compatibility.



The H-Series pumps promised to deliver increased pump life and application longevity – and they delivered on that promise. In the first calendar year after installation, the customer saw a \$27,000 savings in parts and pump replacements, with a 52% decrease in overall pump downtime.

Molten Sulfur

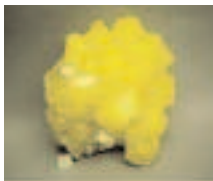

Sulfur is a nonmetal solid element at room conditions. It is used to produce sulfuric acid as well as a variety of other important sulfur-based compounds and products.

Molten sulfur is one of the most difficult chemicals to pump. First, high operating temperatures are needed to keep a normally solid element in a liquid state. Then, precise temperature levels must be maintained – small variations lead to wide changes in viscosity. If the sulfur gets too cold, it sets up in the pump and piping, requiring intensive, expensive downtime; too hot, and it polymerizes, turning into a near solid.

So it takes an extraordinary pump to transfer and meter sulfur – and that’s precisely what Liquiflo supplied to its customers for this difficult application. Liquiflo’s highly specialized gear pump design uses a magnetic sealless drive, a heating jacket on the pump end to maintain temperature, and a patented Dual Kan enclosure. The Dual Kan is fitted over the driven magnetic area, so sulfur can be melted before the pump is started. These features allow the sulfur to stay within a very tight temperature band. As a result, the pump is able to deliver accurate, pulse-free flows; and, liquid temperatures are kept within the optimum range, allowing trouble-free operation.



Application Case Histories for Liquiflo Gear Pumps

PFC Coolants for Temperature Controllers



Perfluorocarbon (PFC) coolants are a popular alternative to environmentally hazardous chlorinated solvents. One specialty application for PFC coolants is in high-performance chillers used for stringent semiconductor applications. The chiller systems require highly reliable temperature control, so every part of the system must be absolutely dependable.

This is why a customer's system designers picked the Liquiflo gear pump to circulate the PFC coolant through the system. To accurately control temperatures, the coolant must be constantly

circulating at precisely metered speeds – and absolutely no leakage of the expensive coolant could be tolerated. The Liquiflo mag-drive gear pump, specifically engineered to maximize reliability, was the only pump project engineers felt could deliver the essential uptime required for this application. Chiller systems using Liquiflo gear pumps have seen measured MTBM (mean time between maintenance) in excess of 40,000 hours!

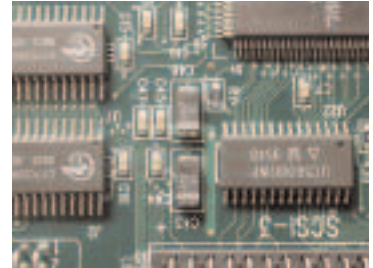

Polymer Flocculant for Water Treatment

A wire technology company was using a progressive cavity pump to add metered doses of polymer flocculant to a clarifier water treatment system. The flow was highly viscous, and spiked with lumps of dry polymer. The progressive cavity pump regularly sheared pins, and suffered extensive stator and rotor wear. Seals and packing glands needed constant maintenance. Plant management replaced it with a Liquiflo gear pump. Using mechanical seals and Teflon bearings, the Liquiflo pump delivered five years of trouble-free service, 24 hours a day, 7 days a week – with only occasional suction and discharge line cleaning needed to maintain like-new performance.



Shear-Sensitive Polymers



A specialty chemical company had narrowed its search for a polymer transfer pump down to either a Liquiflo gear pump or a progressive cavity (PC) pump. The gear pump offered reliability and ease of maintenance, but the progressive cavity pump was known for its low-shear operation – a critical element, since shear could adversely influence the effectiveness of the high-quality polymer solution.

So they evaluated both pumps with the polymer solutions, over a range of speeds and pressures. Using change in viscosity to

measure relative shear (the higher the viscosity, the lower the shear), they discovered that the Liquiflo gear pump actually induced less shear than the progressive cavity pump. Based on these findings, the chemical company made Liquiflo gear pumps the standard component on their polymer solution packages.

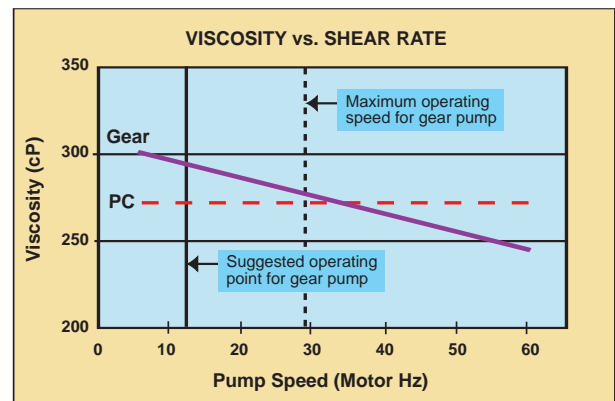

Application Case Histories for Liquiflo Gear Pumps

Sodium Hypochlorite Metering for Wastewater Treatment Plants

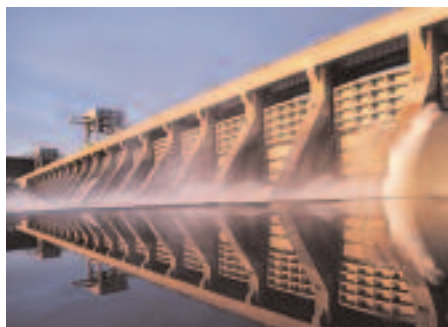

A Texas wastewater treatment plant had trouble with the pumps it used to supply variable flows of 9-11% sodium hypochlorite (NaOCl) to its processes. The tubular diaphragm pumps suffered ruptures that spewed the corrosive chemical into the plant. In addition, the flow suffered from pulses and surges that threatened to upset process balances.

A Liquiflo gear pump was then tried as a replacement. Configured with a mag-drive for sealless, leak-free operation, and titanium construction for corrosion resistance, the Liquiflo pump was designed to provide greater reliability while delivering a range of pulse-free, easy-to-measure media flows.

After 15 months of trouble-free service, the plant maintenance manager considered the Liquiflo solution to be a complete success – in terms of both performance and economy. Metered flows have been far more precise; reliability has been absolute; and, because the Liquiflo pumps eliminated pulsing, they also eliminated the need for dampeners and additional pipe supports.



Solvents for Extraction of Organic Chemicals



A chemical company specializing in the extraction of valuable organic chemicals required large amounts of chlorinated and non-chlorinated solvents in their processes. These thin, non-lubricating fluids have low viscosities and low boiling points, so they're very difficult to pump, and very susceptible to leaks.

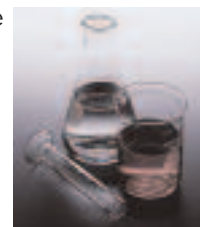

The company chose to use Liquiflo sealless mag-drive gear pumps with coated shafts for their applications with low NPSH, low flows or precise metering requirements. The gear pumps were equipped with air motors, which provided an effective and inexpensive explosion-proof system with variable speed capability. The Liquiflo gear pumps performed exceedingly well in this highly challenging environment.

Sulfuric Acid

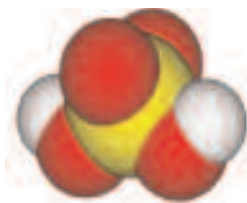

Sulfuric acid (H₂SO₄) is the world's most produced chemical. It is used in the production of batteries, dyes, drugs, insecticides, plastics, steel, paper, drain cleaners, explosives, detergents, fertilizers and many other materials. Sulfuric acid is also used for water treatment, ore processing, oil refining, dehydrating and as a catalyst for chemical reactions.



Aqueous sulfuric acid is typically pumped over a wide range of concentration – from dilute to 100% concentrated. The viscous and corrosive properties of sulfuric acid are highly dependent on concentration and temperature. The hygroscopic and exothermic nature of sulfuric acid can cause its concentration and temperature to change, altering its properties. These facts make sulfuric acid a difficult chemical to handle.

Since sulfuric acid is highly important, corrosive and hazardous, it is no surprise that this chemical is one of Liquiflo's most common pumping applications. A wide selection of standard options and corrosion-resistant materials allow Liquiflo gear pumps to be easily custom-engineered to handle the various properties of sulfuric acid.

H-SERIES HEAVY-DUTY INDUSTRIAL GEAR PUMPS

H-Series

Up to 225 PSI differential pressure

The **H-Series Gear Pumps** were designed as an upgrade to Liquiflo's original 3-Series. With similar outside dimensions and capacities, the H-Series incorporates larger shafts and bearings, allowing them to handle higher pressures with extended service life. The H-Series pumps are available in Sealed and Mag-Drive versions with flows up to approximately **30 GPM** and differential pressures up to **225 PSI**.* * 300 PSI possible on some models. Contact factory.

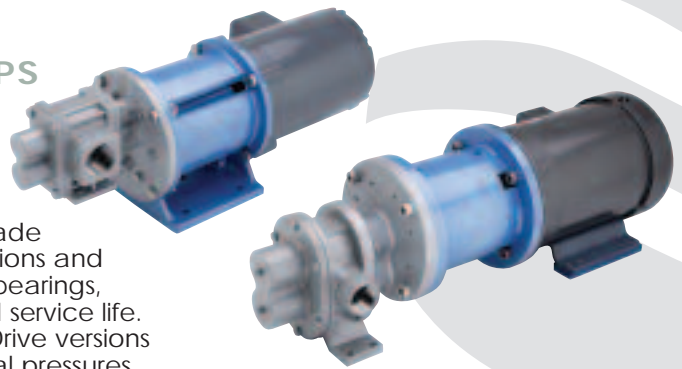

The H-Series is recommended for all new applications as well as an upgrade to any existing 3-Series installations.

H-Series Specifications

SEALED Long-Coupled							
SEALED MAG-DRIVE	H1F H1F-MC	H3F H3F-MC	H5R H5R-MC	H5F H5F-MC	H7N H7N-MC	H7R H7R-MC	H7F H7F-MC
Max Flow Rate	0.5 GPM (1.9 LPM)	1.4 GPM (5.3 LPM)	2.4 GPM (9.1 LPM)	3.4 GPM (13 LPM)	5.4 GPM (20 LPM)	8.6 GPM (33 LPM)	10.7 GPM (40.5 LPM)
Max Diff. Press.	225 PSI (15.5 BAR)	225 PSI (15.5 BAR)	225 PSI (15.5 BAR)	225 PSI (15.5 BAR)	225 PSI (15.5 BAR)	225 PSI (15.5 BAR)	225 PSI (15.5 BAR)
Max Discharge	300 PSI (20.7 BAR)	300 PSI (20.7 BAR)	300 PSI (20.7 BAR)	300 PSI (20.7 BAR)	225 PSI (15.5 BAR)	225 PSI (15.5 BAR)	225 PSI (15.5 BAR)
Max Temp.	500 °F (260 °C)	500 °F (260 °C)	500 °F (260 °C)	500 °F (260 °C)	500 °F (260 °C)	500 °F (260 °C)	500 °F (260 °C)
Max Viscosity	100,000* CPS	100,000* CPS	100,000* CPS	100,000* CPS	100,000* CPS	100,000* CPS	100,000* CPS
Max Speed	1750 RPM	1750 RPM	1750 RPM	1750 RPM	1750 RPM	1750 RPM	1750 RPM
NPSHR @ Max Speed	3 FT (0.9M)	2 FT (0.6M)	2 FT (0.6M)	2 FT (0.6M)	5.2 FT (1.6M)	5.2 FT (1.6M)	5.2 FT (1.6M)
Weight Sealed, LC Sealed, CC Mag-Drive, CC	2.5 LBS (1.1 KGS) 23 LBS (10 KGS) 31 LBS (14 KGS)	2.5 LBS (1.1 KGS) 23 LBS (10 KGS) 31 LBS (14 KGS)	3.5 LBS (1.6 KGS) 24 LBS (11 KGS) 32 LBS (15 KGS)	3.5 LBS (1.6 KGS) 24 LBS (11 KGS) 32 LBS (15 KGS)	6.5 LBS (2.9 KGS) 29 LBS (13 KGS) 36 LBS (16 KGS)	6.5 LBS (2.9 KGS) 29 LBS (13 KGS) 36 LBS (16 KGS)	6.5 LBS (2.9 KGS) 29 LBS (13 KGS) 36 LBS (16 KGS)

* Higher viscosities possible. Contact factory.



LC = Long-Coupled

CC = Close-Coupled

**COMPOSITE
GEAR PUMP
PERFORMANCE
CURVES**

TEST FLUID:
OIL (100 CPS)



			
H9R H9R-MC	H9F H9F-MC	H12R H12R-MC	H12F H12F-MC
15 GPM (57 LPM)	21.5 GPM (81.4 LPM)	22 GPM (83 LPM)	29 GPM (110 LPM)
225 PSI (15.5 BAR)	225 PSI (15.5 BAR)	225 PSI (15.5 BAR)	225 PSI (15.5 BAR)
225 PSI (15.5 BAR)	225 PSI (15.5 BAR)	270 PSI (18.6 BAR)	270 PSI (18.6 BAR)
500 °F (260 °C)	500 °F (260 °C)	500 °F (260 °C)	500 °F (260 °C)
100,000* CPS	100,000* CPS	100,000* CPS	100,000* CPS
1750 RPM	1750 RPM	1150 RPM	1150 RPM
4 FT (1.2M)	3 FT (0.9M)	5 FT (1.5M)	5 FT (1.5M)
8 LBS (3.6 KGS) 34 LBS (15 KGS) 38 LBS (17 KGS)	10 LBS (4.5 KGS) 36 LBS (16 KGS) 40 LBS (18 KGS)	52 LBS (24 KGS) 77 LBS (35 KGS) 95 LBS (43 KGS)	52 LBS (24 KGS) 77 LBS (35 KGS) 95 LBS (43 KGS)

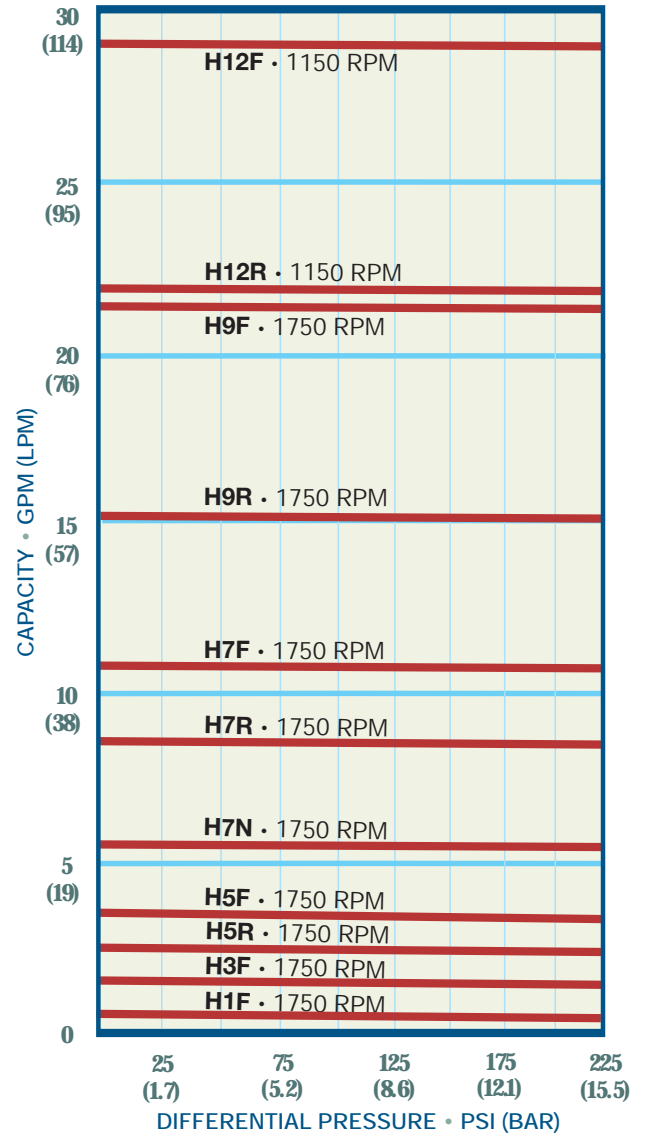

PUMP MODEL CODING

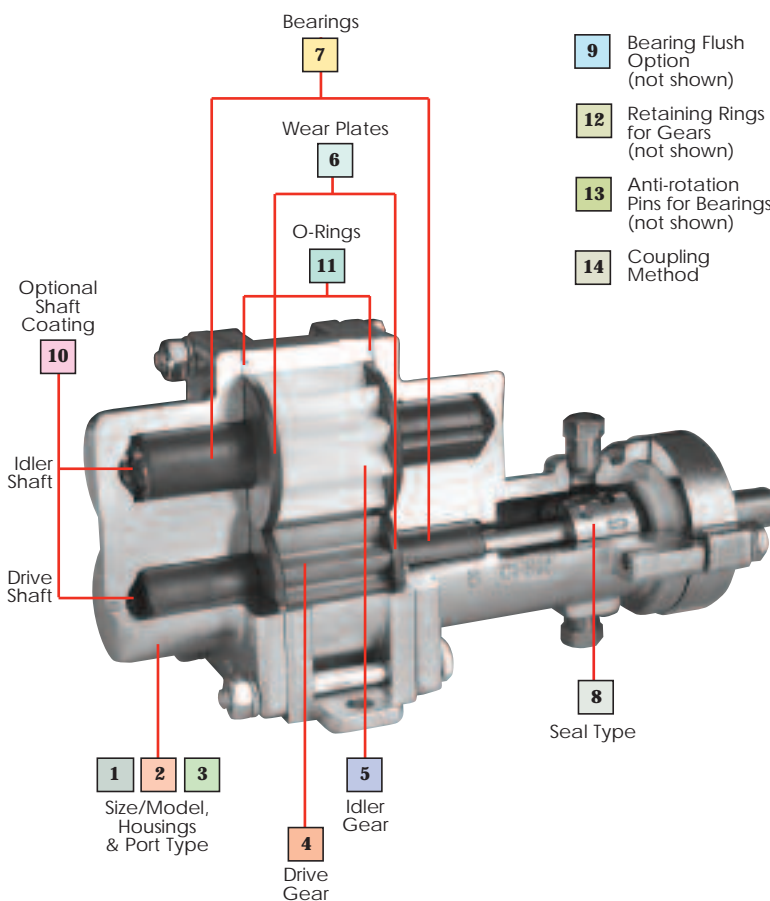

Sealed Pump

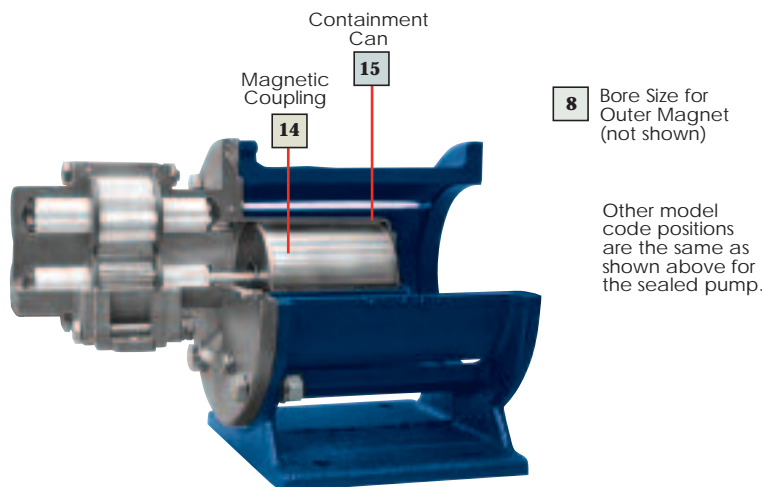

Mag-Drive Pump

EXAMPLE:

H5FS6PEEU000000, designates a Model H5F Pump with Single Mechanical Seal.

H5F	S	6	P	E	E	U	0	0	0	0	0	0	0	0	0	0	0	0	0	
1&2	3	4	5	6	7	8	9	10	11	12	13	14	15							

Pos.	Description	Selection
1 & 2	Pump Model	H5E H5F Pump
3	Housing Mat'l	S 316 SS NPT
4	Drive Gear Mat'l	6 316 SS
5	Idler Gear Mat'l	P PEEK
6	Wear Plate Mat'l	E Carbon 60
7	Bearing Mat'l	E Carbon 60
8	Seal Type	U Single-Int, Carbon-SiC
9	Bearing Flush	Q None
10	Shaft Coating	Q None
11	O-Rings	Q Teflon
12	Retaining Ring	Q 316 SS
13	Bearing Pins	Q Teflon
14	Coupling Method	Q Close-Coupled (56C motor)
15	N/A	

Liquiflo's Model Code describes both the pump's size and materials selected. This model code is required for the future identification of your pump when reordering either a pump or replacement parts. Model code is permanently stamped into pump housing.

- Available
- ⊗ Not Available
- CF Contact Factory

Flanges available:

ANSI, DIN, JIS, or slip joint flanges conforming to the dimensions of the standard.

CONNECTION SIZES

	H1/H3	H5	H7	H9R	H9F	H12
NPT/BSPT	1/4	1/2	3/4	1	1 1/4	1 1/4
ANSI 150# RF FLG	1/2	1/2	3/4	1	1 1/4	1 1/2
DIN PN16	10	15	20	25	32	40
JIS 10K	10	15	20	25	32	40

Sample Model No. **H5** **F** **S** **6** **P** **E** **E** **U** **0** **0** **0** **0** **0** **0** **0** **0** **0** **0**

Position No. 1 2 3 4 5 6 7 8 9 10 11 12 13 14 15

Position Model	1 Pump Model	H1	H3	H5	H7N	H7	H9	H12
Position Model	F = Full Capacity R = Reduced Capacity	■	■	■	⊗	■	■	■
Position Model	S = 316 SS NPT L = 316 SS Flanged X = 316 SS BSPT H = Alloy-C NPT C = Alloy-C Flanged Y = Alloy-C BSPT	■	■	■	■	■	■	■
Position Model	1 = Alloy-C 3 = Teflon 6 = 316 SS P = PEEK	■	■	■	■	■	■	■
Position Model	1 = Alloy-C 3 = Teflon 6 = 316 SS 8 = Ryton P = PEEK	■	■	■	■	■	■	■
Position Model	3 = Teflon 4 = Ceramic (SiC) E = Carbon 60 P = PEEK	■	■	■	■	■	■	■
Position Model	3 = Teflon B = Silicon Carbide E = Carbon 60 P = PEEK	■	■	■	■	■	■	■
Position Model	0 = 0.625" (NEMA 56C/56HC) 1 = 0.875" (NEMA 143/145TC) 2 = 14 mm (IEC 71 - B5) 3 = 19 mm (IEC 80 - B5) 4 = 24 mm (IEC 90 - B5) 5 = 1.125" (NEMA 182/184TC) 6 = 1.375" (NEMA 213/215TC) 7 = 1.625" (NEMA 254/256TC)	■	■	■	■	■	■	⊗
Position Model	U = Single-Int Carbon - SiC S = Single-Int Teflon - SiC F = Double Carbon - SiC H = Double Teflon - SiC L = Packing Teflon R = Packing Graphoil	■	■	■	■	■	■	■
Position Model	0 = Standard Housings 1 = External Bearing Flush 2 = Internal Bearing Flush	■	■	■	■	■	■	⊗
Position Model	0 = Material same as housing (uncoated) 1 = Ceramic 2 = Tungsten Carbide	■	■	■	■	■	■	■
Position Model	0 = Teflon 6 = 316 SS / PTFE encapsulated B = Buna-N E = EPDM V = Viton K = Kalrez	⊗	■	■	■	■	■	■
Position Model	0 = Material same as housing	■	■	■	■	■	■	■
Position Model	0 = Teflon 1 = Alloy-C 6 = 316 SS	■	■	■	■	■	■	⊗
Position Model	0 = Close-Coupled (NEMA 56C/56HC) 1 = Close-Coupled (NEMA 143/145TC) 2 = Close-Coupled (IEC 71 - B5) 3 = Close-Coupled (IEC 80 - B5) 4 = Close-Coupled (IEC 90 - B5) 5 = Close-Coupled (NEMA 182/184TC) 6 = Close-Coupled (NEMA 213/215TC) 7 = Close-Coupled (NEMA 254/256TC) 9 = Long-Coupled	■	■	■	■	■	■	⊗
Position Model	U = 75 in-lbs B = 120 in-lbs V = 200 in-lbs K = 325 in-lbs J = 650 in-lbs	■	■	■	■	■	■	⊗
Position Model	S = Single Wall Can D = Dual Kan	■	■	■	■	■	■	■
Suffix Trim Options	- 8 = Temperature Trim - 9D = Viscosity Trim (double clearance) - 9T = Viscosity Trim (triple clearance)	■	■	■	■	■	■	■

■ Long-coupled pumps (MC: 0.875" dia. shaft; Sealed: 1.125" dia. shaft)

H1F SEALED H1F-MC MAG-DRIVE



H - SERIES
GEAR PUMP

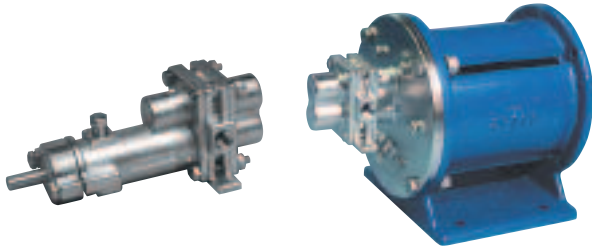

Sealed,
Long-Coupled

Sealed or Mag-Drive,
Close-Coupled

PERFORMANCE CURVES

1 CPS Fluid (Water)

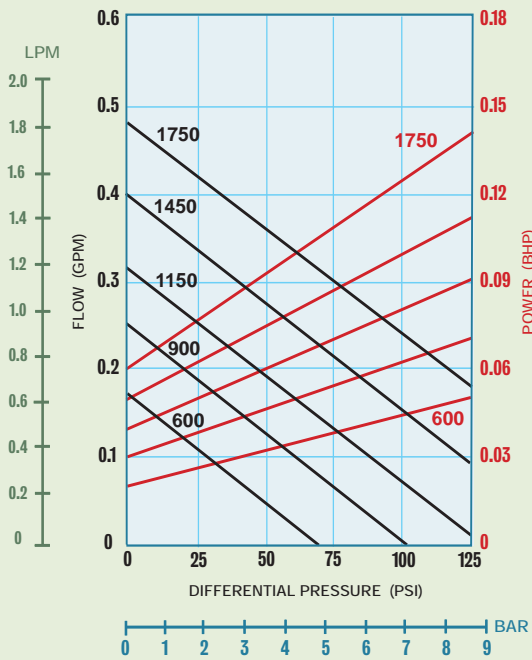

100 CPS Fluid (Oil)

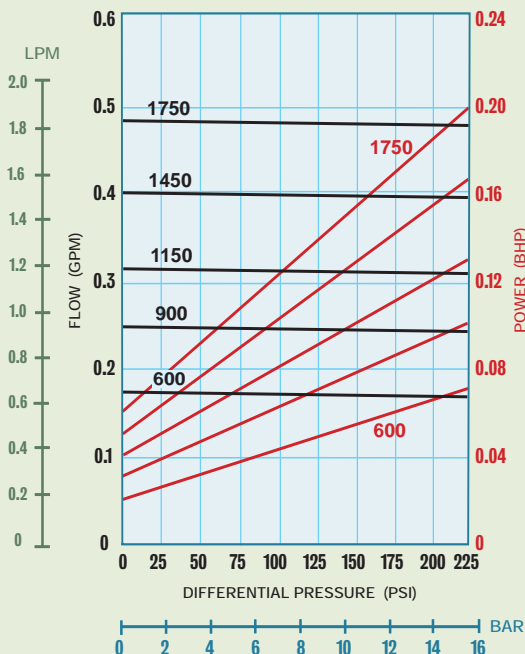

PORT SIZE	1/4" NPT/BSPT or 1/2" FLG
MAX FLOW	0.5 GPM; 1.9 LPM
MAX DIFFERENTIAL PRESSURE	225 PSI; 15.5 BAR
MAX DISCHARGE PRESSURE	300 PSI; 20.7 BAR
MAX TEMPERATURE	500°F; 260°C
MIN TEMPERATURE	-40°F; -40°C
MAX VISCOSITY	100,000* CPS
NPSHR @ 1750 RPM	3 FT; 0.9 M
LIFT (DRY)	0.5 FT; 0.15 M
WEIGHT (without motor)	
SEALED, Long-Coupled	2.5 LBS; 1.1 KGS
SEALED, Close-Coupled	23 LBS; 10 KGS
MAG-DRIVE, Close-Coupled	31 LBS; 14 KGS

* Higher viscosities possible. Contact factory.

Dimensional Data (inches)

H1F Sealed, Long-Coupled

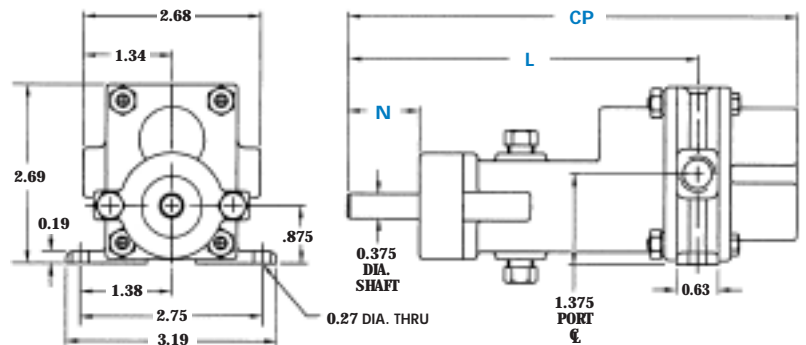

SEAL CONFIGURATIONS

DIMENSION	SINGLE & DOUBLE MECHANICAL SEALS	PACKING
CP ⁽¹⁾	6.94	6.94
L	5.44	5.44
N	1.12	1.19 ⁽²⁾

NOTES: (1) Add .31 inches for Bearing Flush Plugs.
(2) Minimum dimension.

Dimensional Data (inches)

H1F-MC & H1F Sealed, Close-Coupled

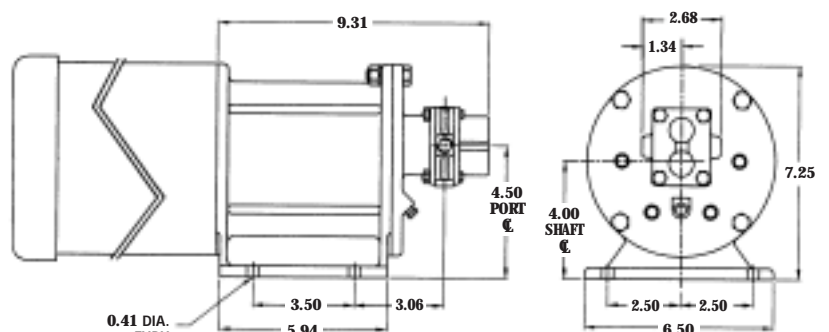

H3F SEALED H3F-MC MAG-DRIVE



H - SERIES
GEAR PUMP

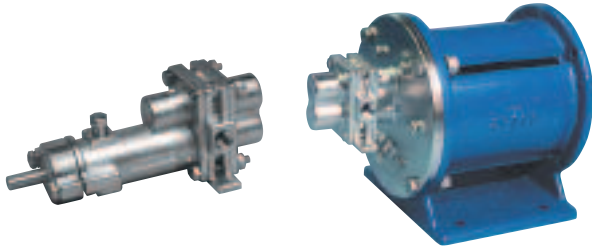

Sealed,
Long-Coupled

Sealed or Mag-Drive,
Close-Coupled

PERFORMANCE CURVES

1 CPS Fluid (Water)

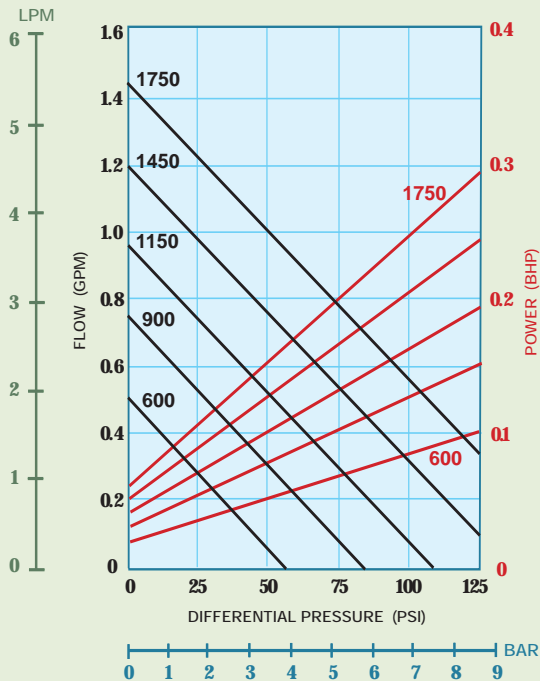

100 CPS Fluid (Oil)

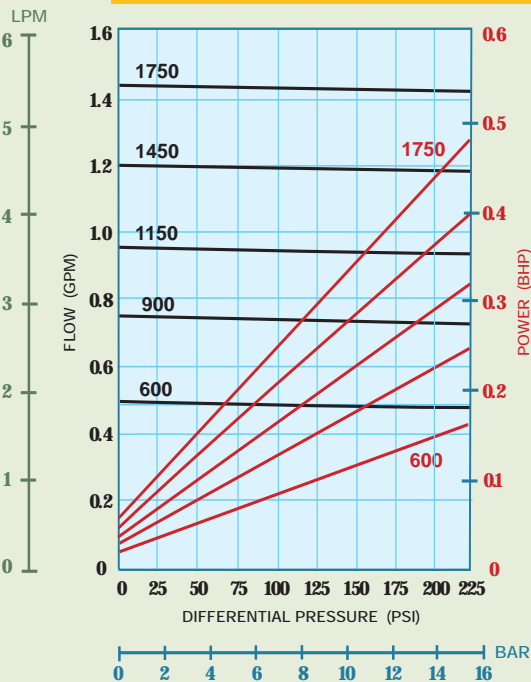

PORT SIZE	1/4" NPT/BSPT or 1/2" FLG
MAX FLOW	1.4 GPM; 5.3 LPM
MAX DIFFERENTIAL PRESSURE	225 PSI; 15.5 BAR
MAX DISCHARGE PRESSURE	300 PSI; 20.7 BAR
MAX TEMPERATURE	500°F; 260°C
MIN TEMPERATURE	-40°F; -40°C
MAX VISCOSITY	100,000* CPS
NPSHR @ 1750 RPM	2 FT; 0.6 M
LIFT (DRY)	1.5 FT; 0.45 M
WEIGHT (without motor)	
SEALED, Long-Coupled	2.5 LBS; 1.1 KGS
SEALED, Close-Coupled	23 LBS; 10 KGS
MAG-DRIVE, Close-Coupled	31 LBS; 14 KGS

* Higher viscosities possible. Contact factory.

Dimensional Data (inches)

H3F Sealed, Long-Coupled

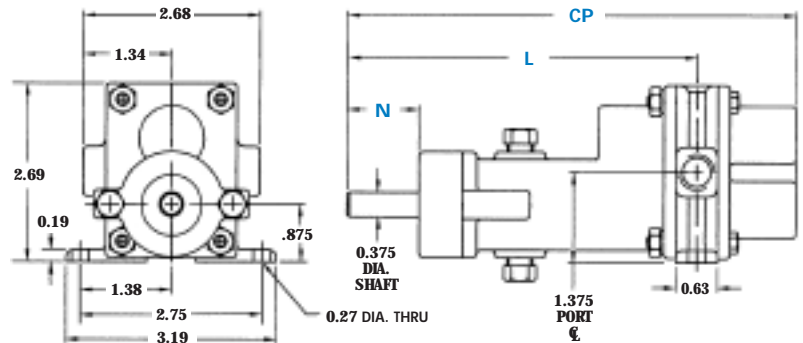

SEAL CONFIGURATIONS

DIMENSION	SINGLE & DOUBLE MECHANICAL SEALS	PACKING
CP(1)	6.94	6.94
L	5.44	5.44
N	1.12	1.19(2)

NOTES: (1) Add .31 inches for Bearing Flush Plugs.
(2) Minimum dimension.

Dimensional Data (inches)

H3F-MC & H3F Sealed, Close-Coupled

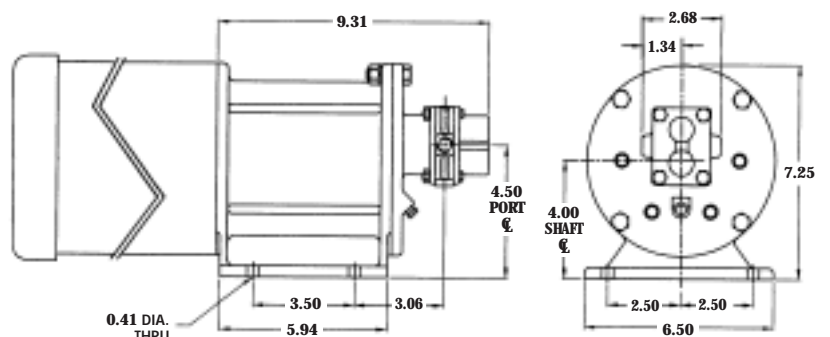

H5R SEALED H5R-MC MAG-DRIVE



H - SERIES
GEAR PUMP

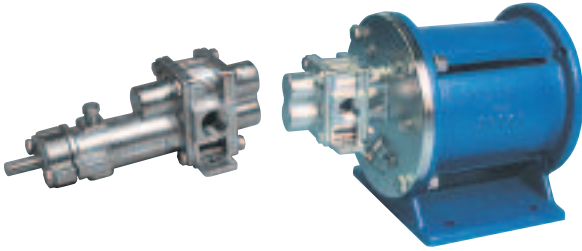

Sealed,
Long-Coupled

Sealed or Mag-Drive,
Close-Coupled

PERFORMANCE CURVES

1 CPS Fluid (Water)

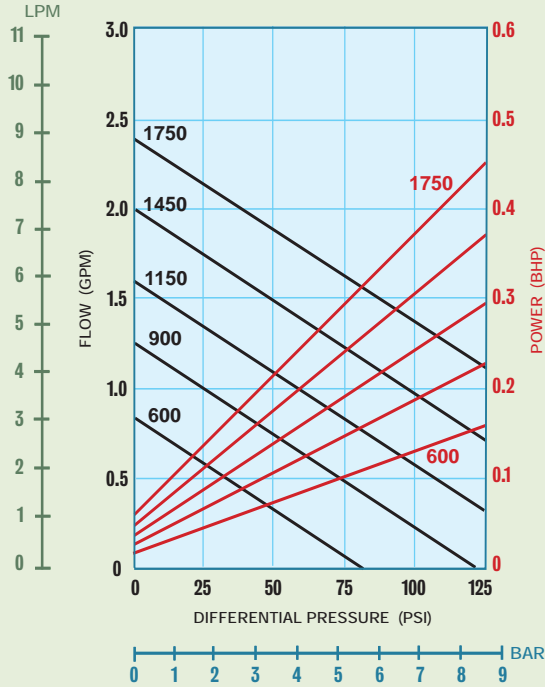

100 CPS Fluid (Oil)

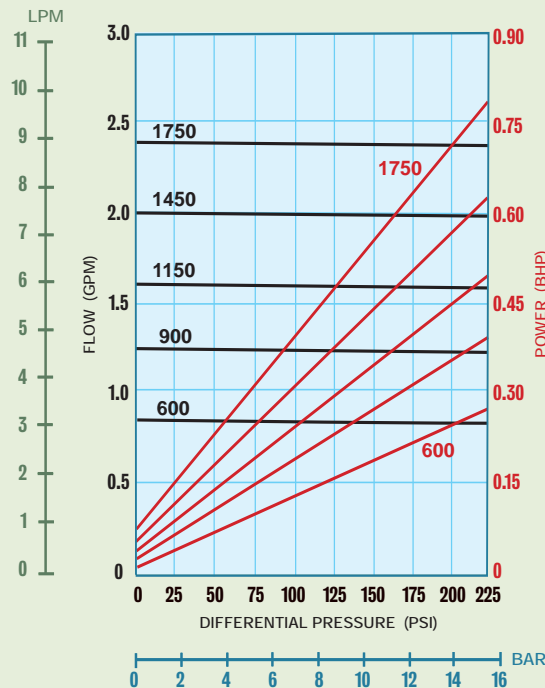

PORT SIZE	1/2" NPT/BSPT/FLG
MAX FLOW	2.4 GPM; 9.1 LPM
MAX DIFFERENTIAL PRESSURE	225 PSI; 15.5 BAR
MAX DISCHARGE PRESSURE	300 PSI; 20.7 BAR
MAX TEMPERATURE	500°F; 260°C
MIN TEMPERATURE	-40°F; -40°C
MAX VISCOSITY	100,000* CPS
NPSHR @ 1750 RPM	2 FT; 0.6 M
LIFT (DRY)	2 FT; 0.6 M
WEIGHT (without motor)	
SEALED, Long-Coupled	3.5 LBS; 1.6 KGS
SEALED, Close-Coupled	24 LBS; 11 KGS
MAG-DRIVE, Close-Coupled	32 LBS; 15 KGS

* Higher viscosities possible. Contact factory.

Dimensional Data (inches)

H5R Sealed, Long-Coupled

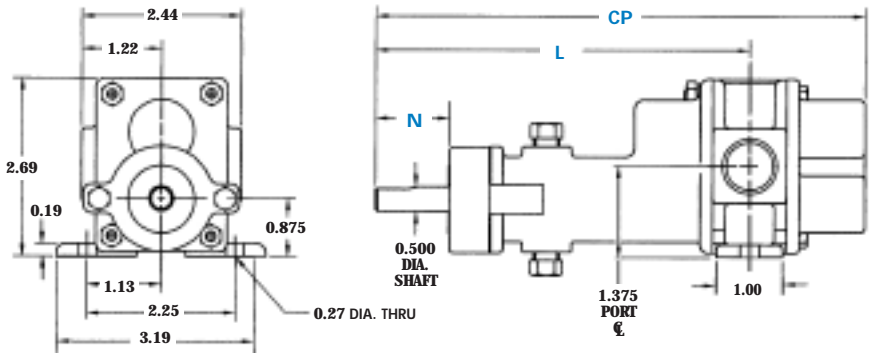

SEAL CONFIGURATIONS

DIMENSION	SINGLE & DOUBLE MECHANICAL SEALS	PACKING
CP ⁽¹⁾	7.42	7.42
L	5.67	5.67
N	1.12	1.13 ⁽²⁾

NOTES: (1) Add .31 inches for Bearing Flush Plugs.
(2) Minimum dimension.

Dimensional Data (inches)

H5R-MC & H5R Sealed, Close-Coupled

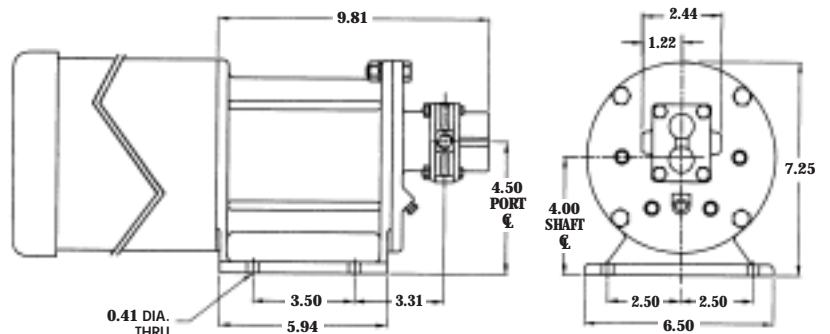

H5F SEALED H5F-MC MAG-DRIVE



H - SERIES
GEAR PUMP

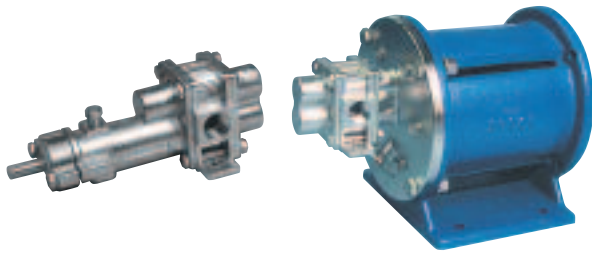

Sealed,
Long-Coupled

Sealed or Mag-Drive,
Close-Coupled

PERFORMANCE CURVES

1 CPS Fluid (Water)

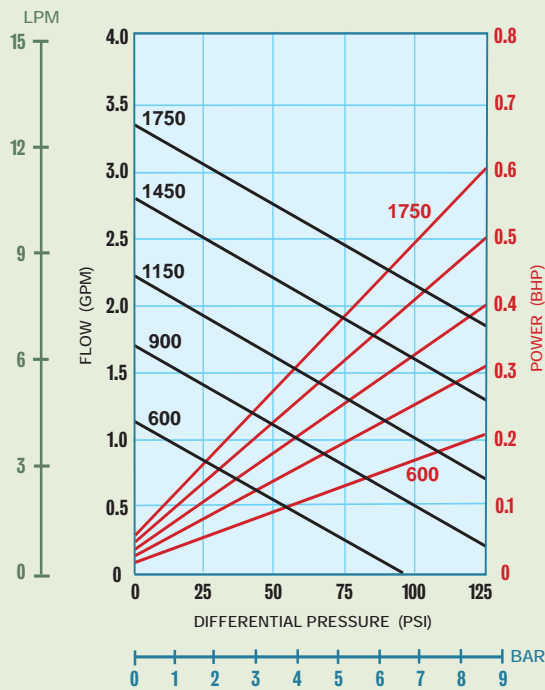

100 CPS Fluid (Oil)

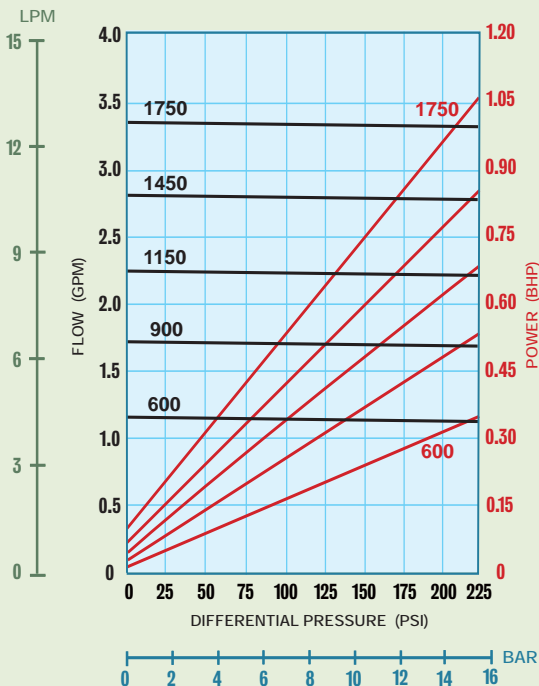

PORT SIZE 1/2" NPT/BSPT/FLG

MAX FLOW 3.4 GPM; 13 LPM

MAX DIFFERENTIAL PRESSURE 225 PSI; 15.5 BAR

MAX DISCHARGE PRESSURE 300 PSI; 20.7 BAR

MAX TEMPERATURE 500°F; 260°C

MIN TEMPERATURE -40°F; -40°C

MAX VISCOSITY 100,000* CPS

NPSHR @ 1750 RPM 2 FT; 0.6 M

LIFT (DRY) 4 FT; 1.2 M

WEIGHT (without motor)

SEALED, Long-Coupled 3.5 LBS; 1.6 KGS

SEALED, Close-Coupled 24 LBS; 11 KGS

MAG-DRIVE, Close-Coupled 32 LBS; 15 KGS

* Higher viscosities possible. Contact factory.

Dimensional Data (inches)

H5F Sealed, Long-Coupled

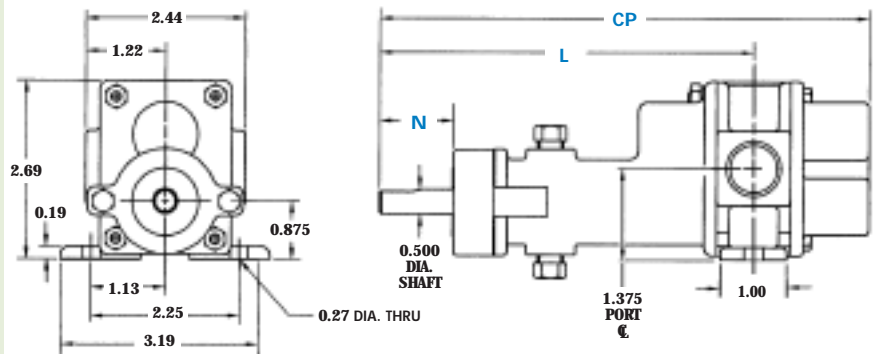

SEAL CONFIGURATIONS

DIMENSION	SINGLE & DOUBLE MECHANICAL SEALS	PACKING
CP ⁽¹⁾	7.42	7.42
L	5.67	5.67
N	1.12	1.13 ⁽²⁾

NOTES: (1) Add .31 inches for Bearing Flush Plugs.
(2) Minimum dimension.

Dimensional Data (inches)

H5F-MC & H5F Sealed, Close-Coupled

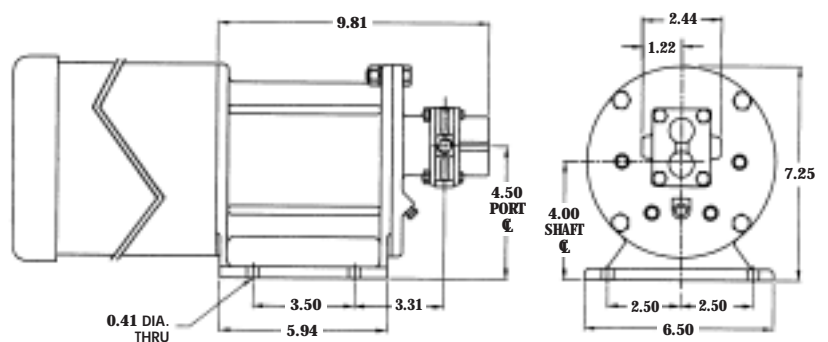

H7N SEALED H7N-MC MAG-DRIVE



H - SERIES
GEAR PUMP

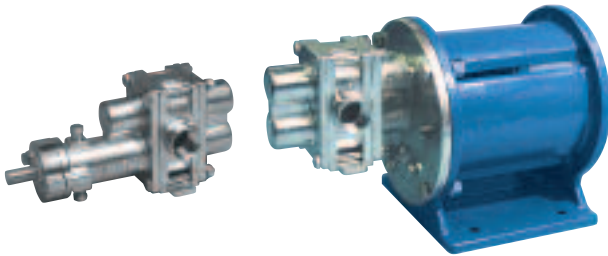

Sealed,
Long-Coupled

Sealed or Mag-Drive,
Close-Coupled

PERFORMANCE CURVES

1 CPS Fluid (Water)

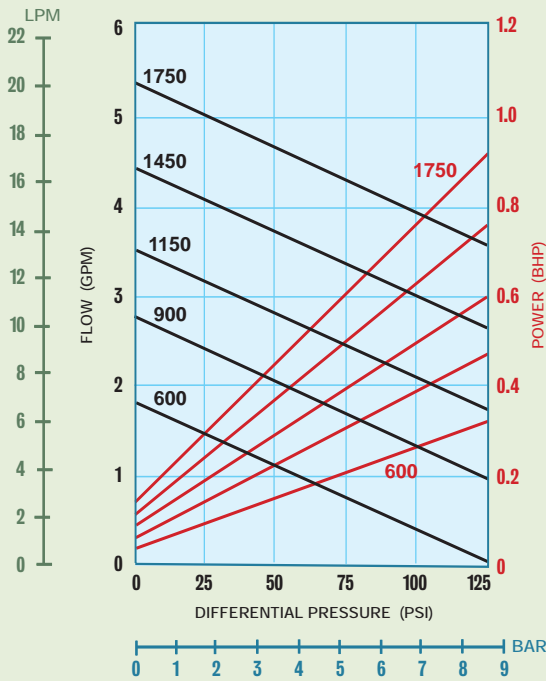

100 CPS Fluid (Oil)

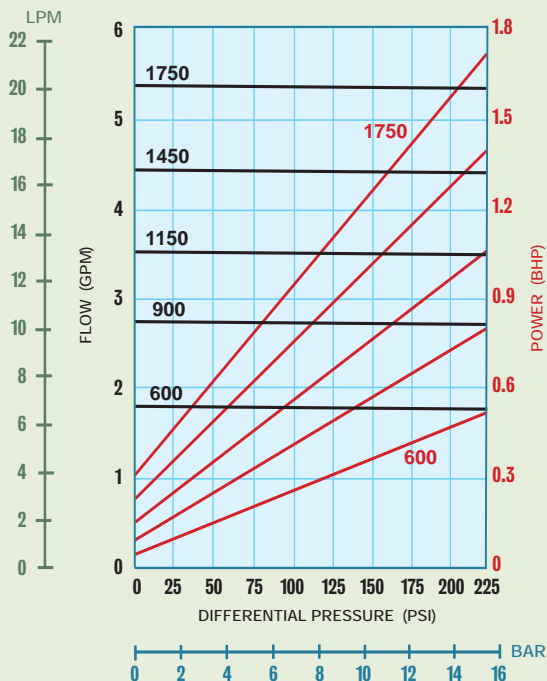

PORT SIZE	3/4" NPT/BSPT/FLG
MAX FLOW	5.4 GPM; 20 LPM
MAX DIFFERENTIAL PRESSURE	225 PSI; 15.5 BAR
MAX DISCHARGE PRESSURE	225 PSI; 15.5 BAR
MAX TEMPERATURE	500°F; 260°C
MIN TEMPERATURE	-40°F; -40°C
MAX VISCOSITY	100,000* CPS
NPSHR @ 1750 RPM	5.2 FT; 1.6 M
LIFT (DRY)	6 FT; 1.8 M
WEIGHT (without motor)	
SEALED, Long-Coupled	6.5 LBS; 3 KGS
SEALED, Close-Coupled	29 LBS; 13 KGS
MAG-DRIVE, Close-Coupled	36 LBS; 16 KGS

* Higher viscosities possible. Contact factory.

Dimensional Data (inches)

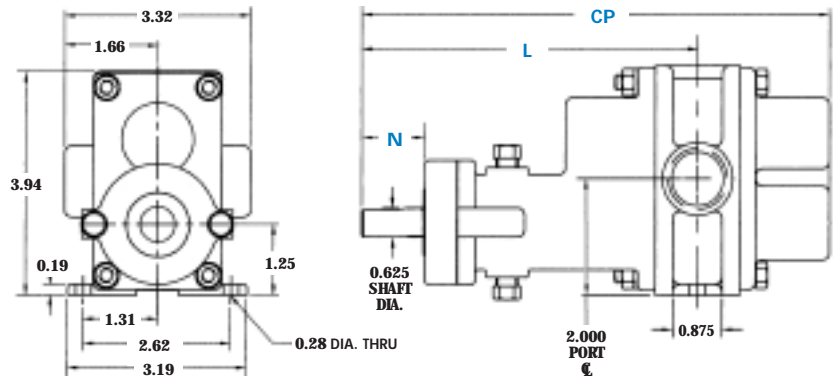

H7N Sealed, Long-Coupled

DIMENSION	SEAL CONFIGURATIONS	
	SINGLE & DOUBLE MECHANICAL SEALS	PACKING
CP ⁽¹⁾	8.20	8.20
L	5.98	5.98
N	1.23	1.25 ⁽²⁾

NOTES: (1) Add .31 inches for Bearing Flush Plugs.
(2) Minimum dimension.

Dimensional Data (inches)

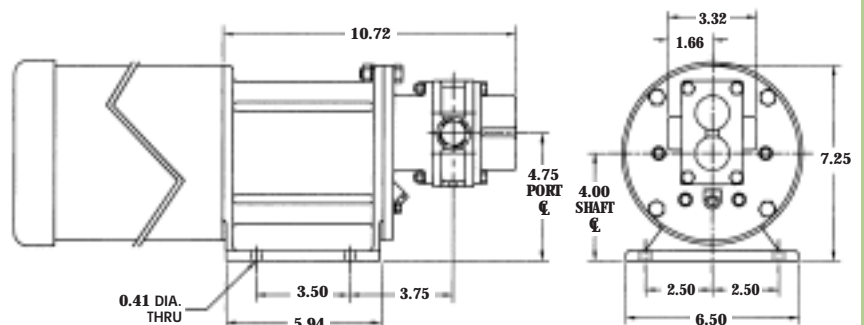

H7N-MC & H7N Sealed, Close-Coupled

H7R SEALED H7R-MC MAG-DRIVE



H - SERIES
GEAR PUMP

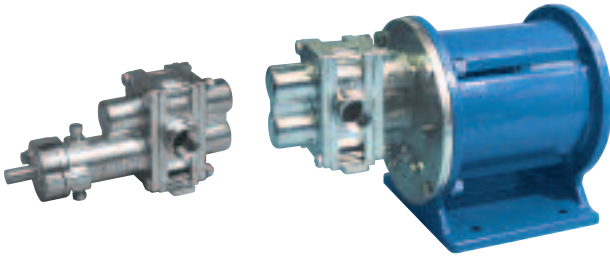

Sealed,
Long-Coupled

Sealed or Mag-Drive,
Close-Coupled

PERFORMANCE CURVES

1 CPS Fluid (Water)

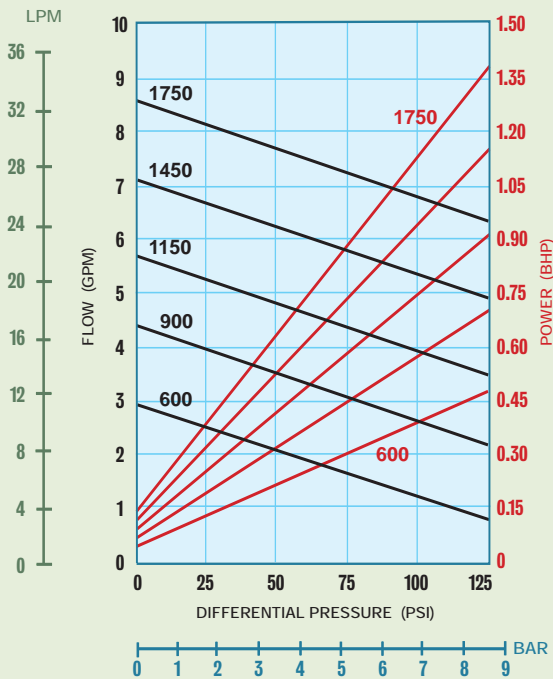

100 CPS Fluid (Oil)

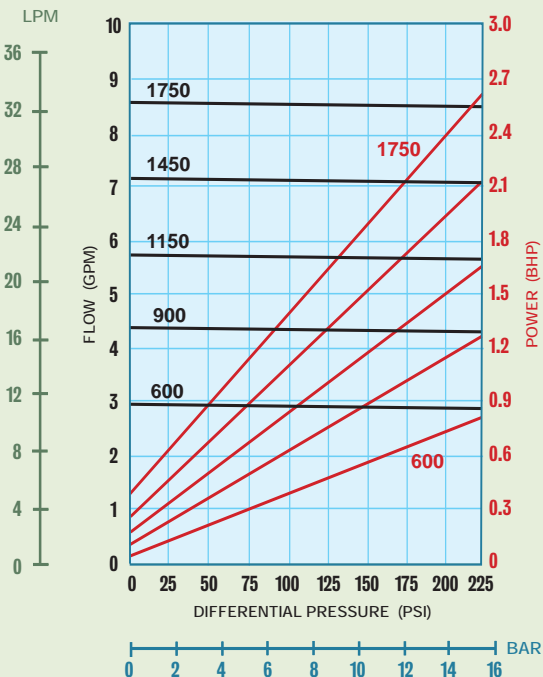

PORT SIZE	3/4" NPT/BSPT/FLG
MAX FLOW	8.6 GPM; 33 LPM
MAX DIFFERENTIAL PRESSURE	225 PSI; 15.5 BAR
MAX DISCHARGE PRESSURE	225 PSI; 15.5 BAR
MAX TEMPERATURE	500°F; 260°C
MIN TEMPERATURE	-40°F; -40°C
MAX VISCOSITY	100,000* CPS
NPSHR @ 1750 RPM	5.2 FT; 1.6 M
LIFT (DRY)	6 FT; 1.8 M
WEIGHT (without motor)	
SEALED, Long-Coupled	6.5 LBS; 3 KGS
SEALED, Close-Coupled	29 LBS; 13 KGS
MAG-DRIVE, Close-Coupled	36 LBS; 16 KGS

* Higher viscosities possible. Contact factory.

Dimensional Data (inches)

H7R Sealed, Long-Coupled

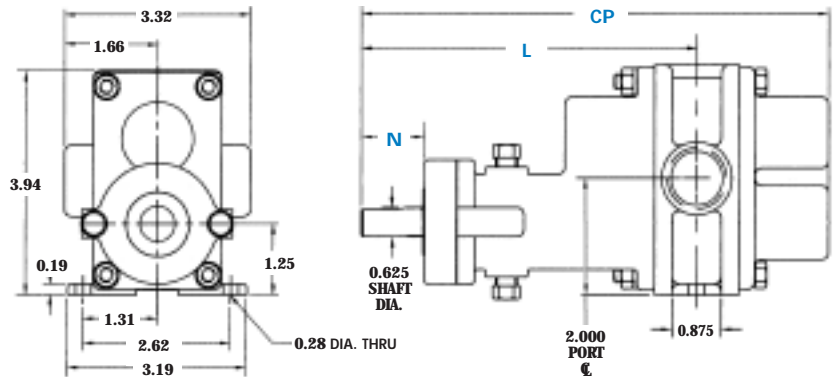

SEAL CONFIGURATIONS

DIMENSION	SEAL CONFIGURATIONS	
	SINGLE & DOUBLE MECHANICAL SEALS	PACKING
CP ⁽¹⁾	8.20	8.20
L	5.98	5.98
N	1.23	1.25 ⁽²⁾

NOTES: (1) Add .31 inches for Bearing Flush Plugs.
(2) Minimum dimension.

Dimensional Data (inches)

H7R-MC & H7R Sealed, Close-Coupled

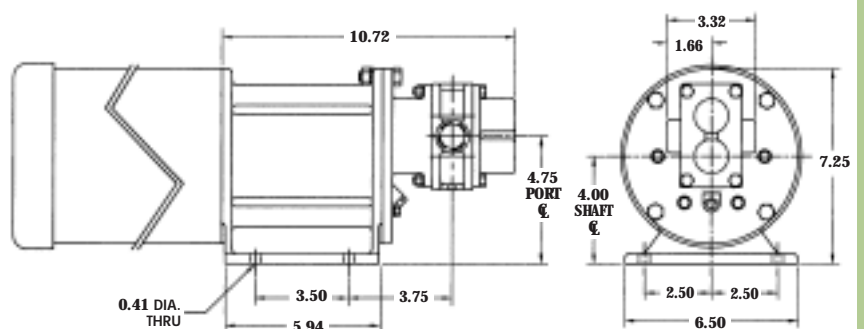

H7F SEALED H7F-MC MAG-DRIVE



H - SERIES
GEAR PUMP

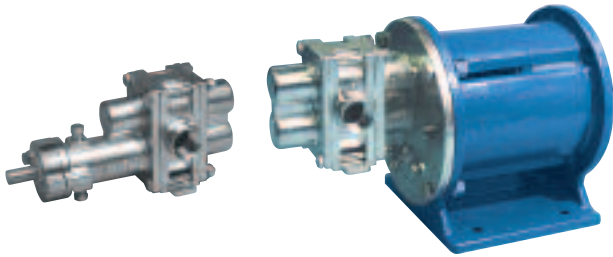

Sealed,
Long-Coupled

Sealed or Mag-Drive,
Close-Coupled

PERFORMANCE CURVES

1 CPS Fluid (Water)

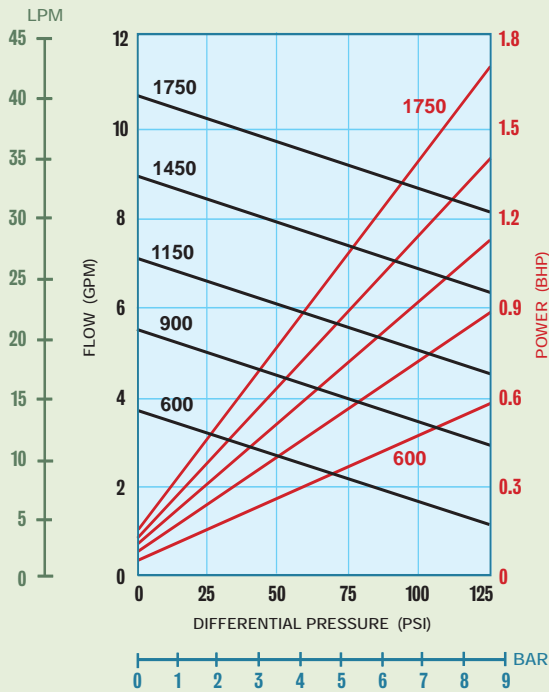

100 CPS Fluid (Oil)

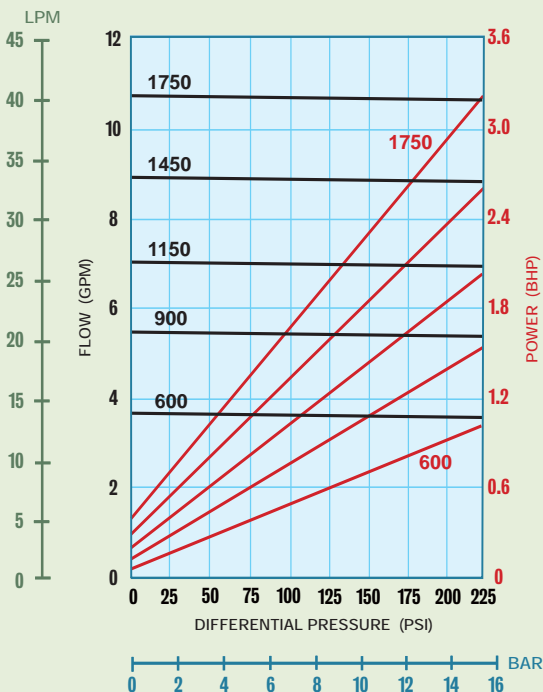

PORT SIZE	3/4" NPT/BSPT/FLG
MAX FLOW	10.7 GPM; 40.5 LPM
MAX DIFFERENTIAL PRESSURE	225 PSI; 15.5 BAR
MAX DISCHARGE PRESSURE	225 PSI; 15.5 BAR
MAX TEMPERATURE	500°F; 260°C
MIN TEMPERATURE	-40°F; -40°C
MAX VISCOSITY	100,000* CPS
NPSHR @ 1750 RPM	5.2 FT; 1.6 M
LIFT (DRY)	7 FT; 2.1 M
WEIGHT (without motor)	
SEALED, Long-Coupled	6.5 LBS; 3 KGS
SEALED, Close-Coupled	29 LBS; 13 KGS
MAG-DRIVE, Close-Coupled	36 LBS; 16 KGS

* Higher viscosities possible. Contact factory.

Dimensional Data (inches)

H7F Sealed, Long-Coupled

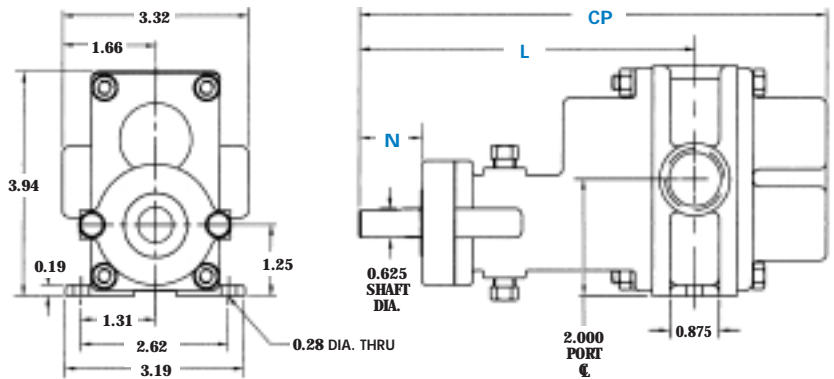

SEAL CONFIGURATIONS

DIMENSION	SINGLE & DOUBLE MECHANICAL SEALS	PACKING
CP ⁽¹⁾	8.32	8.32
L	5.98	5.98
N	1.11	1.13 ⁽²⁾

NOTES: (1) Add .31 inches for Bearing Flush Plugs.
(2) Minimum dimension.

Dimensional Data (inches)

H7F-MC & H7F Sealed, Close-Coupled

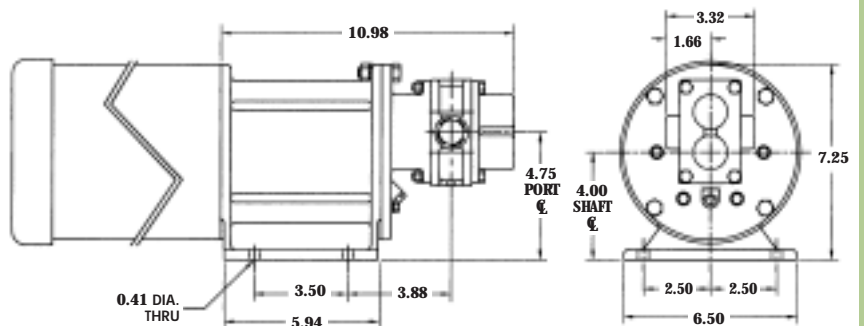

H9R SEALED H9R-MC MAG-DRIVE



H - SERIES
GEAR PUMP

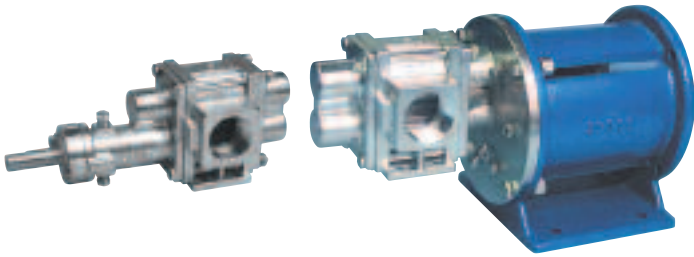

Sealed,
Long-Coupled

Sealed or Mag-Drive,
Close-Coupled

PERFORMANCE CURVES

1 CPS Fluid (Water)

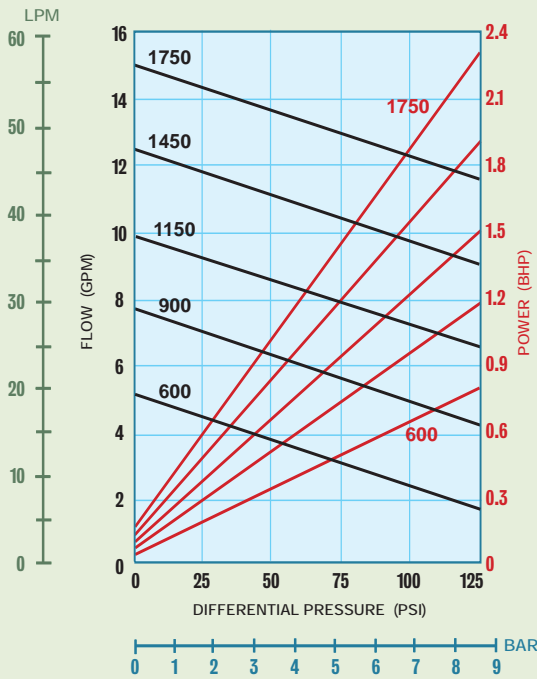

100 CPS Fluid (Oil)

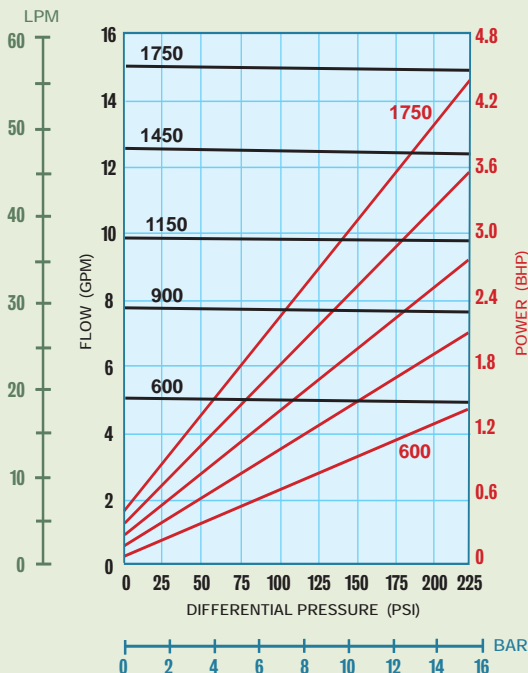

PORT SIZE	1" NPT/BSPT/FLG
MAX FLOW	15 GPM; 57 LPM
MAX DIFFERENTIAL PRESSURE	225 PSI; 15.5 BAR
MAX DISCHARGE PRESSURE	225 PSI; 15.5 BAR
MAX TEMPERATURE	500°F; 260°C
MIN TEMPERATURE	-40°F; -40°C
MAX VISCOSITY	100,000* CPS
NPSHR @ 1750 RPM	4 FT; 1.2 M
LIFT (DRY)	6 FT; 1.8 M
WEIGHT (without motor)	
SEALED, Long-Coupled	8 LBS; 3.6 KGS
SEALED, Close-Coupled	34 LBS; 15 KGS
MAG-DRIVE, Close-Coupled	38 LBS; 17 KGS

* Higher viscosities possible. Contact factory.

Dimensional Data (inches)

H9R Sealed, Long-Coupled

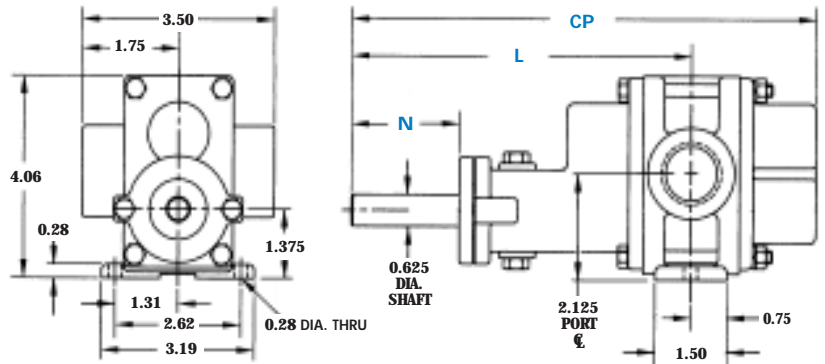

SEAL CONFIGURATIONS

DIMENSION	SINGLE & DOUBLE MECHANICAL SEALS	PACKING
CP(1)	9.68	9.68
L	7.08	7.08
N	2.00	2.00 (2)

NOTES: (1) Add .31 inches for Bearing Flush Plugs.
(2) Minimum dimension.

Dimensional Data (inches)

H9R-MC & H9R Sealed, Close-Coupled

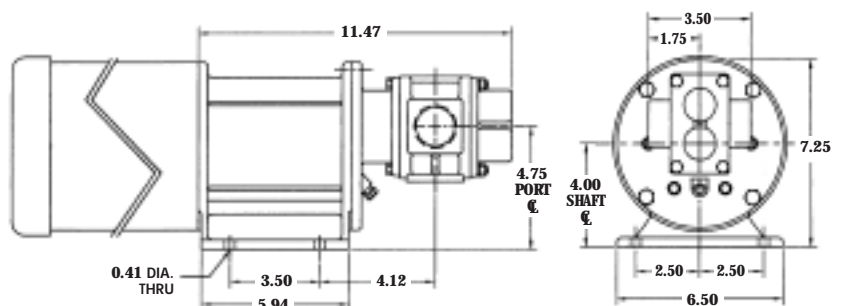

H9F SEALED H9F-MC MAG-DRIVE



H - SERIES
GEAR PUMP

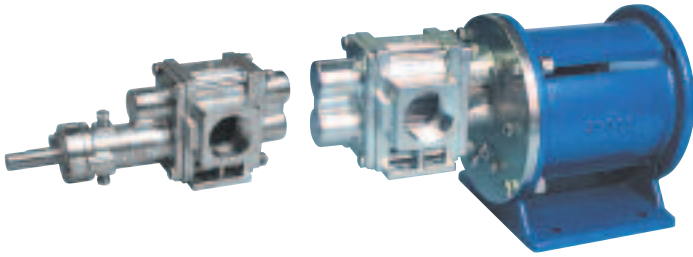

Sealed,
Long-Coupled

Sealed or Mag-Drive,
Close-Coupled

PERFORMANCE CURVES

1 CPS Fluid (Water)

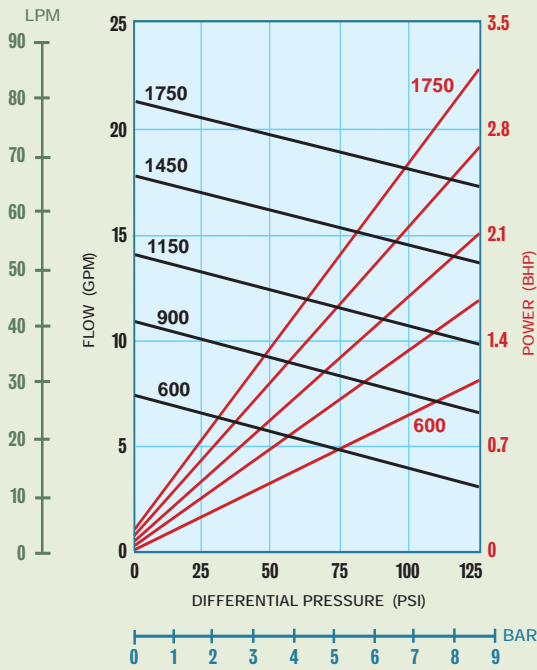

100 CPS Fluid (Oil)

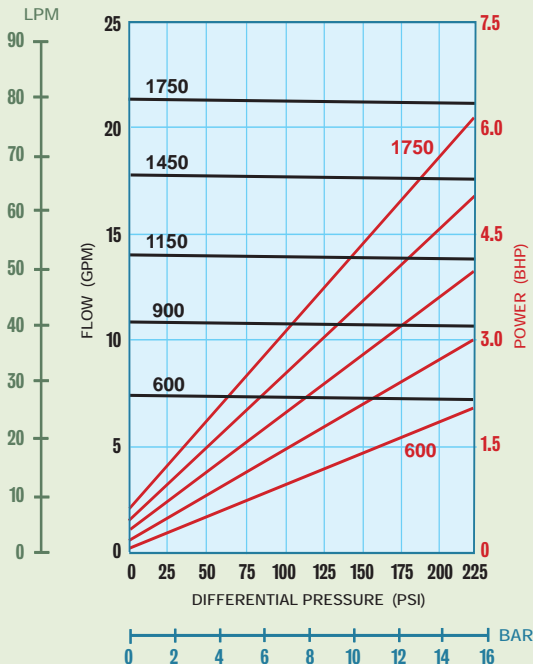

PORT SIZE	1 1/4" NPT/BSPT/FLG
MAX FLOW	21.5 GPM; 81.4 LPM
MAX DIFFERENTIAL PRESSURE	225 PSI; 15.5 BAR
MAX DISCHARGE PRESSURE	225 PSI; 15.5 BAR
MAX TEMPERATURE	500°F; 260°C
MIN TEMPERATURE	-40°F; -40°C
MAX VISCOSITY	100,000* CPS
NPSHR @ 1750 RPM	3 FT; 0.9 M
LIFT (DRY)	14 FT; 4.2 M
WEIGHT (without motor)	
SEALED, Long-Coupled	10 LBS; 4.5 KGS
SEALED, Close-Coupled	36 LBS; 16 KGS
MAG-DRIVE, Close-Coupled	40 LBS; 18 KGS

* Higher viscosities possible. Contact factory.

Dimensional Data (inches)

H9F Sealed, Long-Coupled

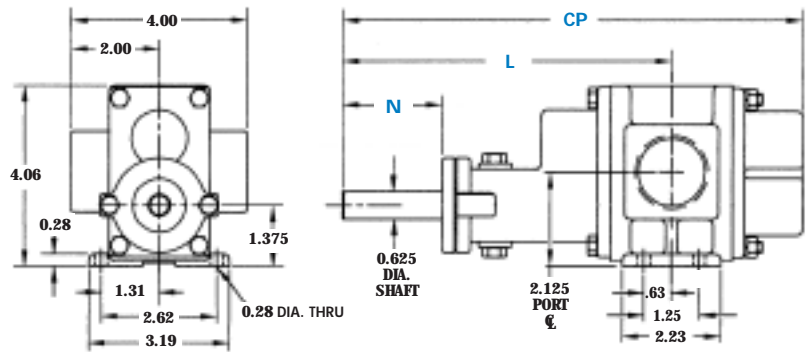

SEAL CONFIGURATIONS

DIMENSION	SEAL CONFIGURATIONS	
	SINGLE & DOUBLE MECHANICAL SEALS	PACKING
CP ⁽¹⁾	10.44	10.44
L	7.47	7.47
N	2.00	2.00 ⁽²⁾

NOTES: (1) Add .31 inches for Bearing Flush Plugs.
(2) Minimum dimension.

Dimensional Data (inches)

H9F-MC & H9F Sealed, Close-Coupled

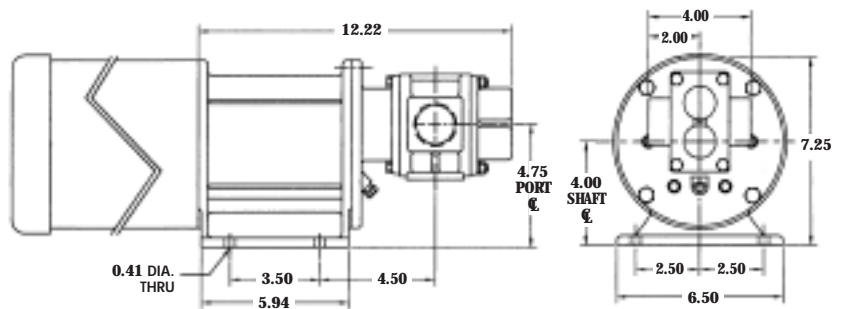

H12R SEALED H12R-MC MAG-DRIVE



H-SERIES
GEAR PUMP

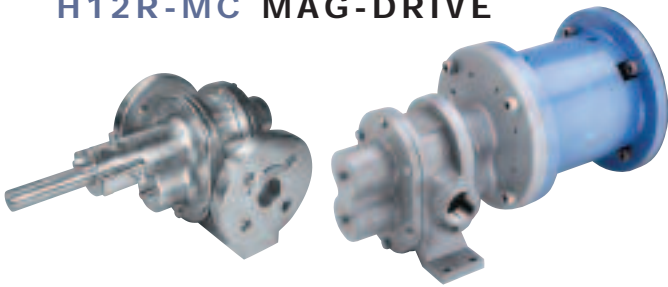

Sealed,
Long-Coupled

Sealed or Mag-Drive,
Close-Coupled

PERFORMANCE CURVES

1 CPS Fluid (Water)

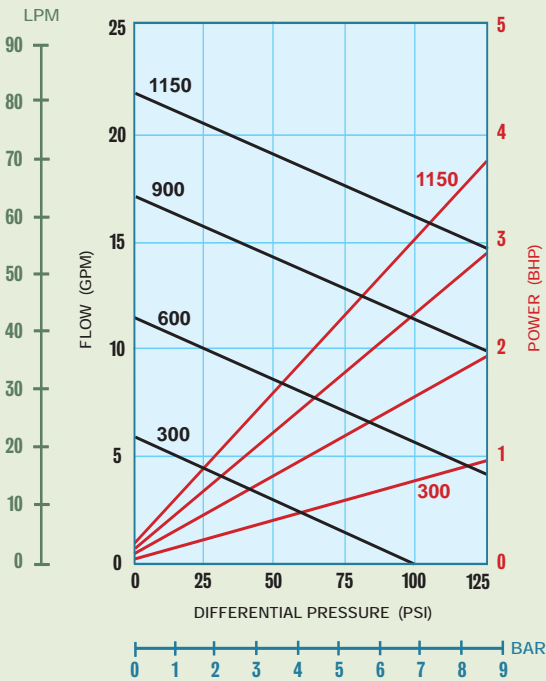

100 CPS Fluid (Oil)

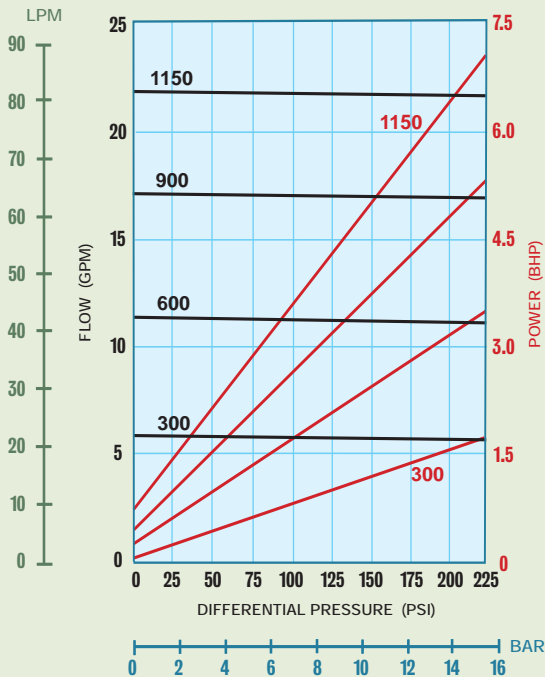

PORT SIZE	1 1/2" FLG or 1 1/4" NPT/BSPT
MAX FLOW	22 GPM; 83 LPM
MAX DIFFERENTIAL PRESSURE	225 PSI; 15.5 BAR
MAX DISCHARGE PRESSURE	270 PSI; 18.6 BAR
MAX TEMPERATURE	500°F; 260°C
MIN TEMPERATURE	-40°F; -40°C
MAX VISCOSITY	100,000* CPS
NPSHR @ 1150 RPM	5 FT; 1.5 M
LIFT (DRY)	15 FT; 4.5 M
WEIGHT (without motor)	
SEALED, Long-Coupled	52 LBS; 24 KGS
SEALED, Close-Coupled	77 LBS; 35 KGS
MAG-DRIVE, Close-Coupled	95 LBS; 43 KGS

* Higher viscosities possible. Contact factory.

Dimensional Data (inches) H12R Sealed, Long-Coupled

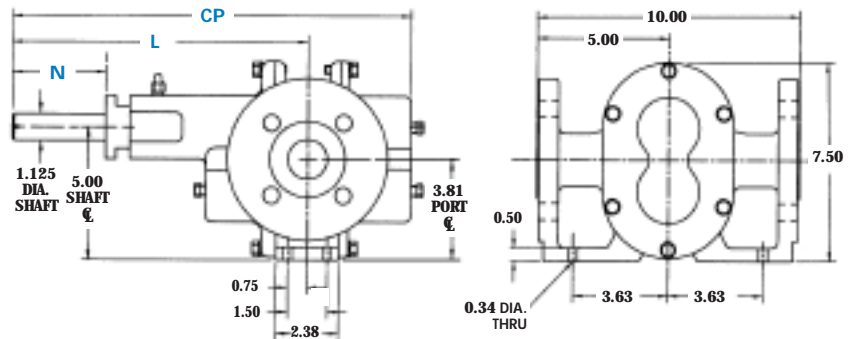

DIMENSION	SEAL CONFIGURATIONS	
	SINGLE & DOUBLE MECHANICAL SEALS	PACKING
CP(1)	13.69	13.69
L	9.75	9.75
N	2.56	2.28 (2)

NOTES: (1) Add .31 inches for Bearing Flush Plugs.
(2) Minimum dimension.

Dimensional Data (inches) H12R-MC & H12R Sealed, Close-Coupled

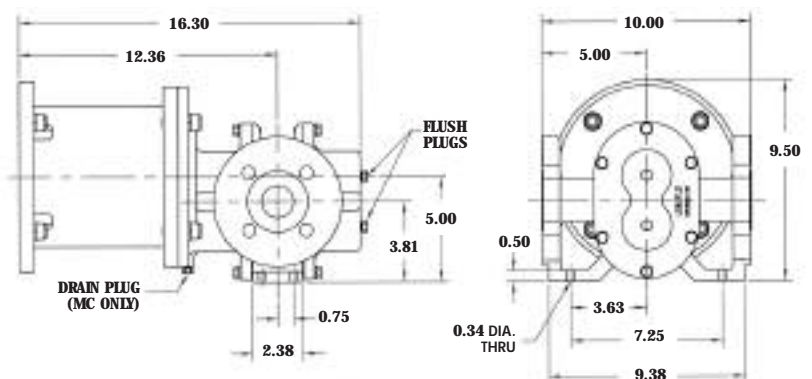

H12F SEALED H12F-MC MAG-DRIVE



H-SERIES
GEAR PUMP

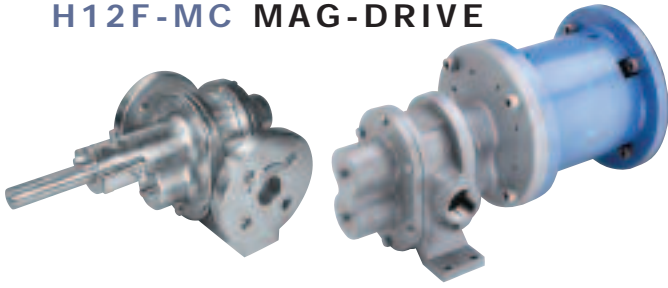

Sealed,
Long-Coupled

Sealed or Mag-Drive,
Close-Coupled

PERFORMANCE CURVES

1 CPS Fluid (Water)

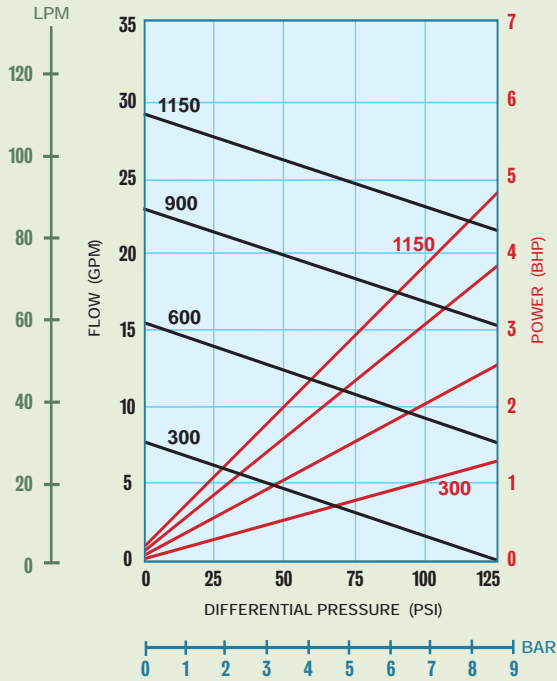

100 CPS Fluid (Oil)

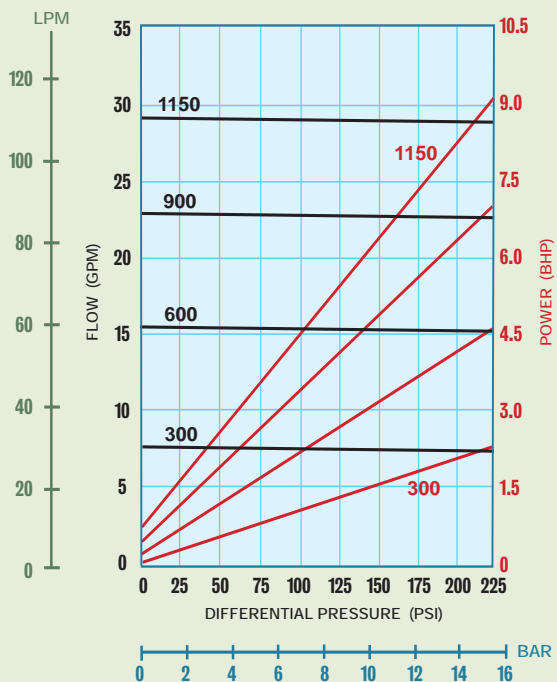

PORT SIZE	1 1/2" FLG or 1 1/4" NPT/BSPT
MAX FLOW	29 GPM; 110 LPM
MAX DIFFERENTIAL PRESSURE	225 PSI; 15.5 BAR
MAX DISCHARGE PRESSURE	270 PSI; 18.6 BAR
MAX TEMPERATURE	500°F; 260°C
MIN TEMPERATURE	-40°F; -40° C
MAX VISCOSITY	100,000* CPS
NPSHR @ 1150 RPM	5 FT; 1.5 M
LIFT (DRY)	17 FT; 5.2 M
WEIGHT (without motor)	
SEALED, Long-Coupled	52 LBS; 24 KGS
SEALED, Close-Coupled	77 LBS; 35 KGS
MAG-DRIVE, Close-Coupled	95 LBS; 43 KGS

* Higher viscosities possible. Contact factory.

Dimensional Data (inches)

H12F Sealed, Long-Coupled

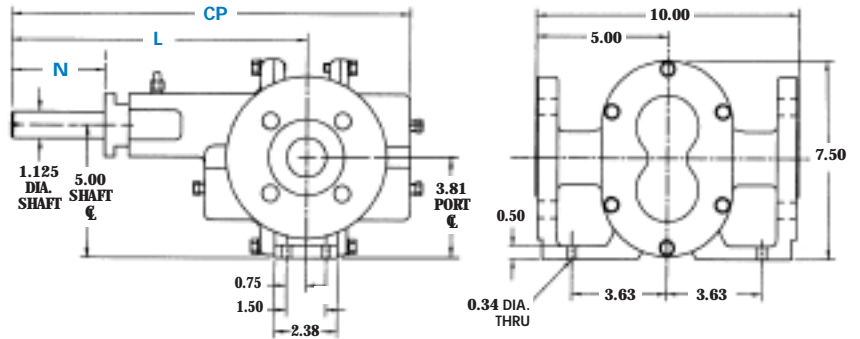

DIMENSION	SEAL CONFIGURATIONS	
	SINGLE & DOUBLE MECHANICAL SEALS	PACKING
CP(1)	13.69	13.69
L	9.75	9.75
N	2.56	2.28 (2)

NOTES: (1) Add .31 inches for Bearing Flush Plugs.
(2) Minimum dimension.

Dimensional Data (inches)

H12F-MC & H12F Sealed, Close-Coupled

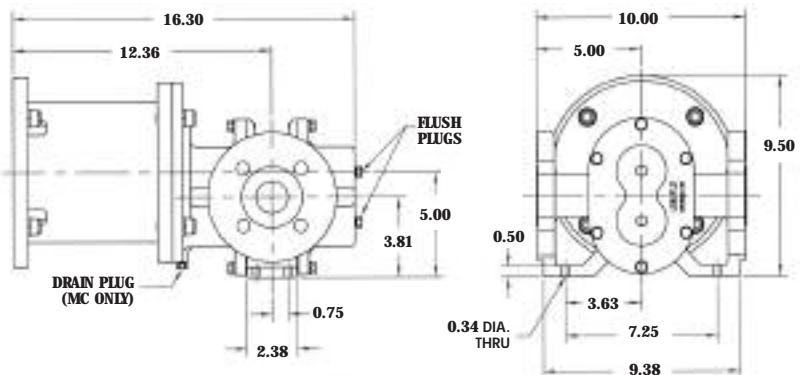

3-SERIES
LIQUIFLO EXTERNAL GEAR PUMPS

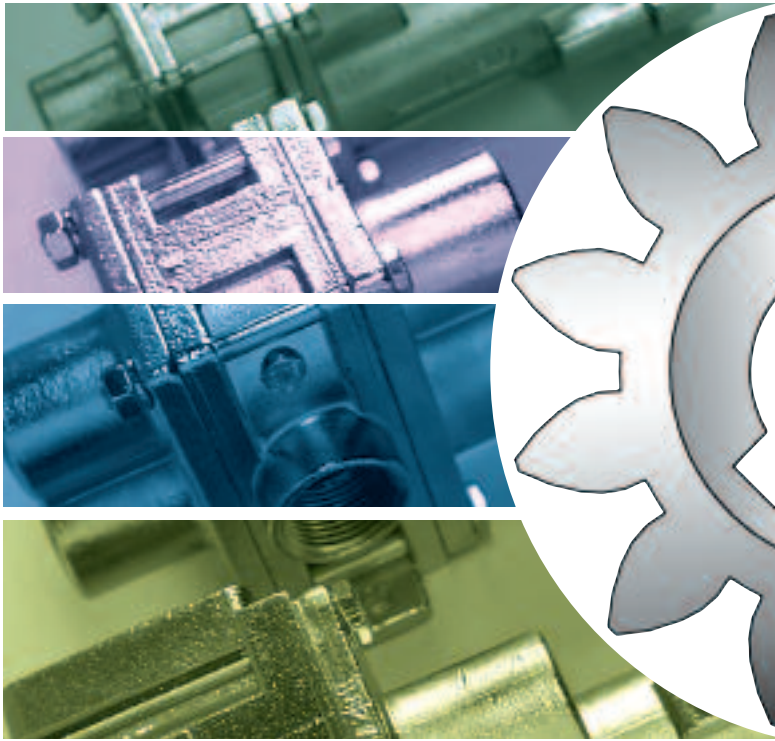

3-SERIES STANDARD DUTY GEAR PUMPS

3-Series

Up to 100 PSI differential pressure

Liquiflo's original **3-Series Gear Pumps** are available in Sealed and Mag-Drive versions with flows up to **58 GPM** and differential pressures up to **100 PSI**.

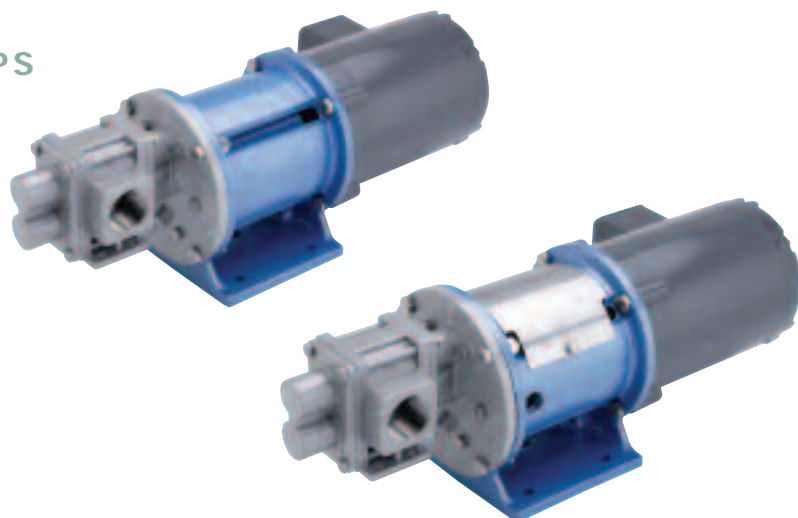

3-Series Specifications

SEALED Long-Coupled										
MAG-DRIVE or SEALED Close-Coupled										
SEALED MAG-DRIVE	31F 31F-MC	33F 33F-MC	35R 35R-MC	35F 35F-MC	37R 37R-MC	37F 37F-MC	39R 39R-MC			
Max Flow	0.5 GPM (1.9 LPM)	1.4 GPM (5.3 LPM)	2.4 GPM (9.1 LPM)	3.4 GPM (13 LPM)	8.6 GPM (33 LPM)	10.7 GPM (40.5 LPM)	15 GPM (57 LPM)			
Max Diff. Press.	100 PSI (7 BAR)	100 PSI (7 BAR)	100 PSI (7 BAR)	100 PSI (7 BAR)	100 PSI (7 BAR)	100 PSI (7 BAR)	100 PSI (7 BAR)			
Max Discharge	300 PSI (20.7 BAR)	300 PSI (20.7 BAR)	300 PSI (20.7 BAR)	300 PSI (20.7 BAR)	225 PSI (15.5 BAR)	225 PSI (15.5 BAR)	225 PSI (15.5 BAR)			
Max Temp.	500 °F (260 °C)	500 °F (260 °C)	500 °F (260 °C)	500 °F (260 °C)	500 °F (260 °C)	500 °F (260 °C)	500 °F (260 °C)			
Max Viscosity	100,000 * CPS	100,000 * CPS	100,000 * CPS	100,000 * CPS	100,000 * CPS	100,000 * CPS	100,000 * CPS			
Max Speed	1750 RPM	1750 RPM	1750 RPM	1750 RPM	1750 RPM	1750 RPM	1750 RPM			
NPSHR @ Max Speed	3 FT (0.9 M)	2 FT (0.6 M)	2 FT (0.6 M)	2 FT (0.6 M)	5.2 FT (1.6 M)	5.2 FT (1.6M)	4 FT (1.2M)			
Weight										
Sealed, LC	2.5 LBS (1.1 KGS)	2.5 LBS (1.1 KGS)	3.5 LBS (1.6 KGS)	3.5 LBS (1.6 KGS)	6.5 LBS (2.9 KGS)	6.5 LBS (2.9 KGS)	8 LBS (3.6 KGS)			
Sealed, CC	23 LBS (10 KGS)	23 LBS (10 KGS)	24 LBS (11 KGS)	24 LBS (11 KGS)	29 LBS (13 KGS)	29 LBS (13 KGS)	34 LBS (15 KGS)			
Mag-Drive, CC	31 LBS (14 KGS)	31 LBS (14 KGS)	32 LBS (15 KGS)	32 LBS (15 KGS)	36 LBS (16 KGS)	36 LBS (16 KGS)	38 LBS (17 KGS)			
Mag-Drive, LC	-	-	-	-	-	-	-			

* Higher viscosities possible. Contact factory.





LC = Long-Coupled

CC = Close-Coupled

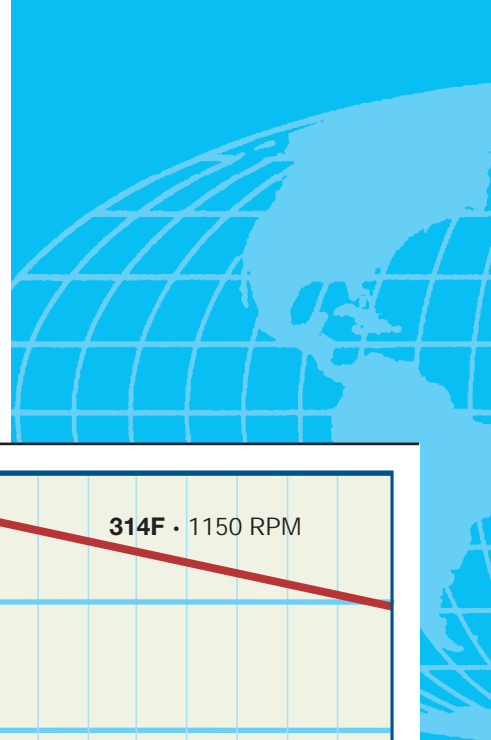
**COMPOSITE
GEAR PUMP
PERFORMANCE
CURVES**

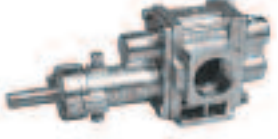
TEST FLUID: WATER
(1 CPS)



	Sealed			
	Mag-Drive			
LONG-COUPLED ONLY				
39F 39F-MC	312R 312R-MC	312F 312F-MC	314F 314F-MC	
21.5 GPM (81.4 LPM)	22 GPM (83 LPM)	29 GPM (110 LPM)	58 GPM (220 LPM)	
100 PSI (7 BAR)	100 PSI (7 BAR)	100 PSI (7 BAR)	100 PSI (7 BAR)	
225 PSI (15.5 BAR)	270 PSI (18.6 BAR)	270 PSI (18.6 BAR)	270 PSI (18.6 BAR)	
500 °F (260 °C)	500 °F (260 °C)	500 °F (260 °C)	500 °F (260 °C)	
100,000 * CPS	100,000 * CPS	100,000 * CPS	100,000 * CPS	
1750 RPM	1150 RPM	1150 RPM	1150 RPM	
3 FT (0.9 M)	5 FT (1.5 M)	5 FT (1.5 M)	3 FT (0.9 M)	
10 LBS (4.5 KGS)	52 LBS (24 KGS)	52 LBS (24 KGS)	67 LBS (30 KGS)	
36 LBS (16 KGS)	-	-	-	
40 LBS (18 KGS)	-	-	-	
-	70 LBS (32 KGS)	70 LBS (32 KGS)	85 LBS (39 KGS)	

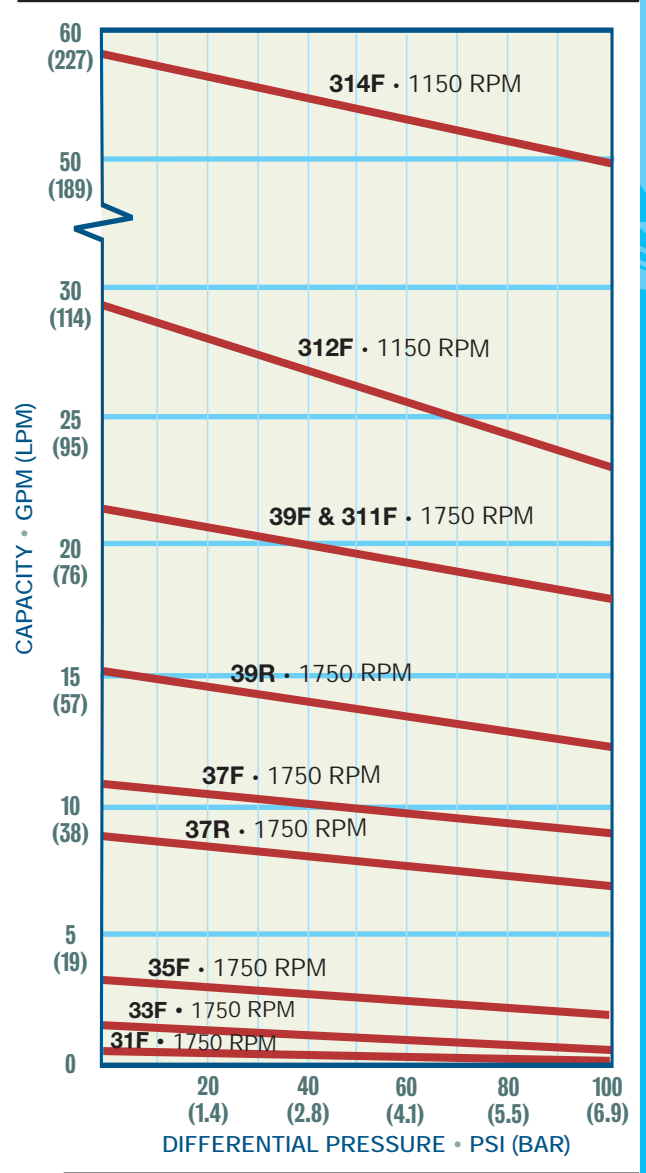

Note: 311F Model is available. Contact factory.

PUMP MODEL CODING

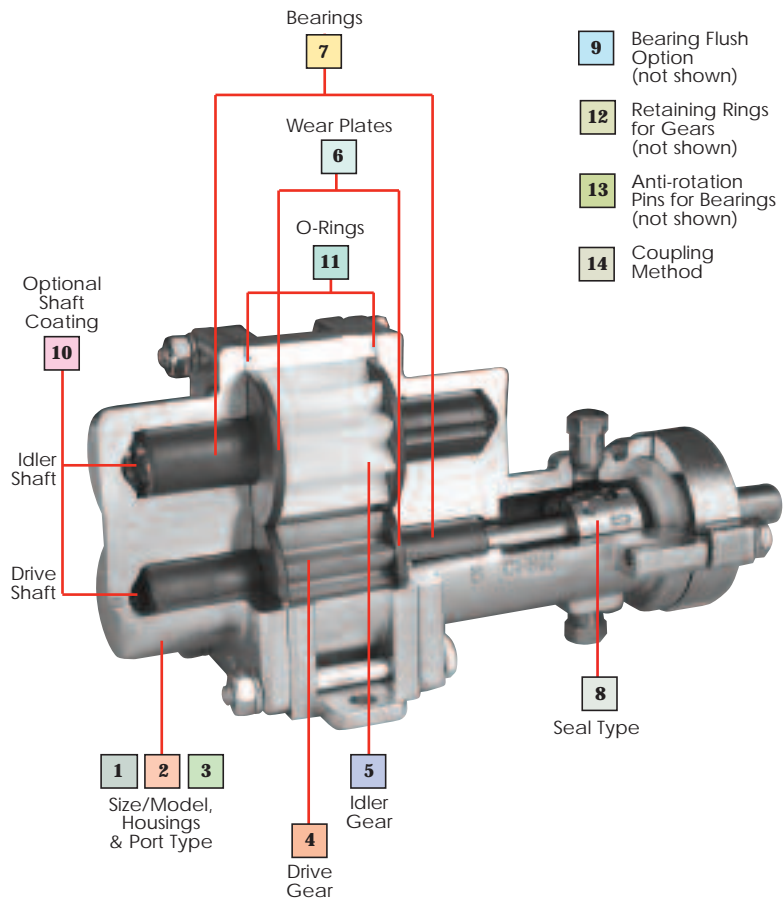

Sealed Pump

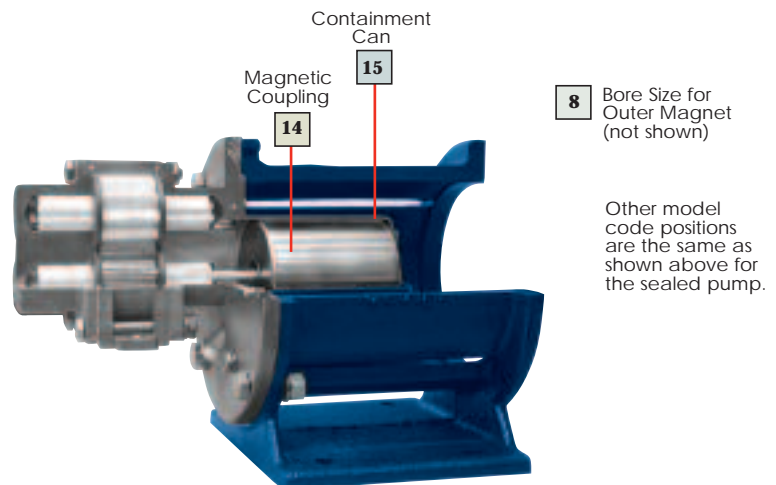

Mag-Drive Pump

Sample Model No. **35 F S 6 P E E U 0 0 0 0 0 9**

Position No. 1 2 3 4 5 6 7 8 9 10 11 12 13 14 15

EXAMPLE:

35FS6PEEU000009, designates a Model 35F Pump with Single Mechanical Seal.

35F S 6 P E E U 0 0 0 0 0 9

1&2 3 4 5 6 7 8 9 10 11 12 13 14 15

Pos.	Description	Selection
1 & 2	Pump Model	35F 35F Pump
3	Housing Mat'l	S 316 SS NPT
4	Drive Gear Mat'l	6 316 SS
5	Idler Gear Mat'l	P PEEK
6	Wear Plate Mat'l	E Carbon 60
7	Bearing Mat'l	E Carbon 60
8	Seal Type	U Single-Int, Carbon-SiC
9	Bearing Flush	0 None
10	Shaft Coating	0 None
11	O-Rings	0 Teflon
12	Retaining Ring	0 316 SS
13	Bearing Pins	0 Teflon
14	Coupling Method	9 Long-Coupled
15	N/A	

Liquiflo's Model Code describes both the pump's size and materials selected. This model code is required for the future identification of your pump when reordering either a pump or replacement parts. Model code is permanently stamped into pump housing.

- Available
- ⊗ Not Available
- CF Contact Factory

Note: Delrin Gears (Code = 5) are no longer available in new pumps but are available for repair and replacement only.

Flanges available:

ANSI, DIN, JIS, or slip joint flanges conforming to the dimensions of the standard.

CONNECTION SIZES

	31/33	35	37	39R	39F	312	314
NPT/BSPT	1/4	1/2	3/4	1	1 1/4	1 1/4	-
ANSI 150# RF	1/2	1/2	3/4	1	1 1/4	1 1/2	2 1/2
DIN PN16	10	15	20	25	32	40	65
JIS 10K	10	15	20	25	32	40	65

Note: 311F pumps available with same features as 39F

Position Model	1 Pump Model	31	33	35	37	39	312	314
Position Model	F = Full Capacity R = Reduced Capacity	■	■	■	■	■	■	■
Position Model		⊗	⊗	■	■	■	■	⊗
Position Basic Material & Port Type	S = 316 SS NPT L = 316 SS Flanged X = 316 SS BSPT H = Alloy-C NPT C = Alloy-C Flanged Y = Alloy-C BSPT D = Alloy-20 NPT W = Alloy-20 BSPT	■	■	■	■	■	■	⊗
Position Drive Gear	1 = Alloy-C 3 = Teflon 6 = 316 SS P = PEEK	■	■	■	■	■	■	■
Position Drive Gear		CF	■	■	■	■	■	■
Position Idler Gear	1 = Alloy-C 2 = Carbon 3 = Teflon 6 = 316 SS 8 = Ryton P = PEEK	■	■	■	■	■	■	■
Position Idler Gear		⊗	■	■	■	■	⊗	⊗
Position Wear Plates	3 = Teflon 4 = Ceramic (SiC) E = Carbon 60 P = PEEK	■	■	■	■	■	■	■
Position Bearings	3 = Teflon B = Silicon Carbide E = Carbon 60 P = PEEK	■	■	■	■	■	■	■
Position Outer Magnet Bore (Mag-Drive)	0 = 0.625" (NEMA 56C/56HC) 1 = 0.875" (NEMA 143/145TC) 2 = 14 mm (IEC 71 - B5) 3 = 19 mm (IEC 80 - B5) 4 = 24 mm (IEC 90 - B5) 5 = 1.125" (NEMA 182/184TC)	■	■	■	■	■	■	■
Position Seal Type (Sealed)	U = Single-Int Carbon - SiC S = Single-Int Teflon - SiC W = Single-Ext Carbon - SiC X = Single-Ext Teflon - SiC F = Double Carbon - SiC H = Double Teflon - SiC J = U-Cup Viton L = Packing Teflon R = Packing Graphoil	■	■	■	■	■	■	■
Position Seal Type (Sealed)		■	■	■	■	⊗	⊗	⊗
Position Bearing Flush Option	0 = Standard Housings 1 = External Bearing Flush 2 = Internal Bearing Flush	■	■	■	■	■	⊗	⊗
Position Shaft Coating	0 = Material same as housing (uncoated) 1 = Ceramic 2 = Tungsten Carbide	■	■	■	■	■	■	■
Position O-Rings	0 = Teflon 6 = 316 SS / PTFE encapsulated B = Buna-N E = EPDM V = Viton K = Kalrez	■	■	■	■	■	■	■
Position Retaining Rings	0 = Material same as housing	■	■	■	■	■	■	■
Position Bearing Pins	0 = Teflon 1 = Alloy-C 6 = 316 SS	■	■	■	■	■	⊗	⊗
Position Coupling Method (Sealed)	0 = Close-Coupled (NEMA 56C/56HC) 1 = Close-Coupled (NEMA 143/145TC) 2 = Close-Coupled (IEC 71 - B5) 3 = Close-Coupled (IEC 80 - B5) 4 = Close-Coupled (IEC 90 - B5) 5 = Close-Coupled (NEMA 182/184TC) 9 = Long-Coupled	■	■	■	■	■	■	■
Position Coupling Method (Sealed)		■	■	■	■	■	■	■
Position Magnetic Coupling (Mag Drive)	U = 75 in-lbs B = 120 in-lbs V = 200 in-lbs K = 325 in-lbs J = 650 in-lbs	■	■	■	■	■	■	■
Position Magnetic Coupling (Mag Drive)		⊗	⊗	⊗	⊗	⊗	⊗	⊗
Position Containment Can	S = Single Wall Can D = Dual Kan	■	■	■	■	■	■	■
Suffix Trim Options	- 8 = Temperature Trim - 9D = Viscosity Trim (double clearance) - 9T = Viscosity Trim (triple clearance)	■	■	■	■	■	■	■

■ Long-coupled pumps (MC: 0.875" dia. shaft; Sealed: 1.000" dia. shaft)

31F SEALED 31F-MC MAG-DRIVE



3 - SERIES
GEAR PUMP

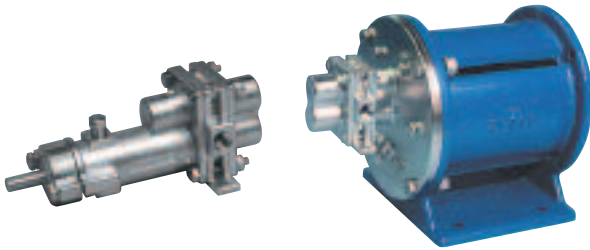

Sealed,
Long-Coupled

Sealed or Mag-Drive,
Close-Coupled

PERFORMANCE CURVES

1 CPS Fluid (Water)

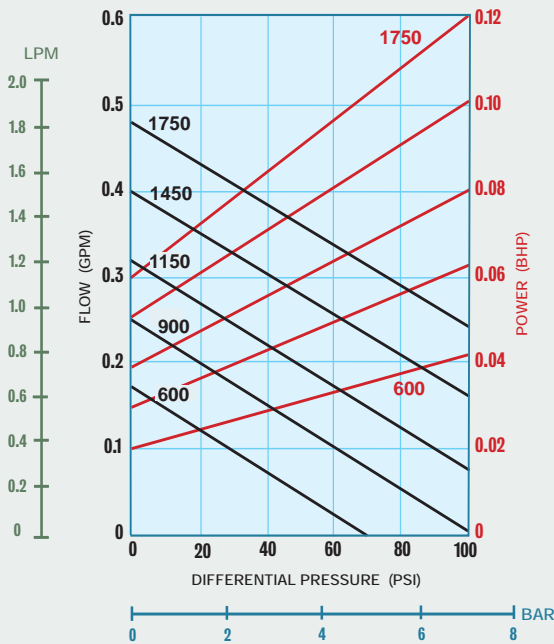

100 CPS Fluid (Oil)

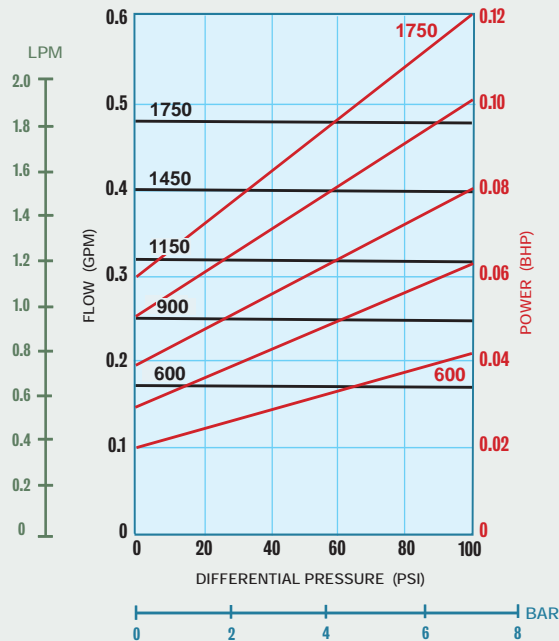

PORT SIZE	1/4" NPT/BSPT or 1/2" FLG
MAX FLOW	0.5 GPM; 1.9 LPM
MAX DIFFERENTIAL PRESSURE	100 PSI; 7 BAR
MAX DISCHARGE PRESSURE	300 PSI; 20.7 BAR
MAX TEMPERATURE	500°F; 260°C
MIN TEMPERATURE	-40°F; -40°C
MAX VISCOSITY	100,000* CPS
NPSHR @ 1750 RPM	3 FT; 0.9 M
LIFT (DRY)	0.5 FT; 0.15 M
WEIGHT (without motor)	
SEALED, Long-Coupled	2.5 LBS; 1.1 KGS
SEALED, Close-Coupled	23 LBS; 10 KGS
MAG-DRIVE, Close-Coupled	31 LBS; 14 KGS

* Higher viscosities possible. Contact factory.

Dimensional Data (inches)

31F Sealed, Long-Coupled

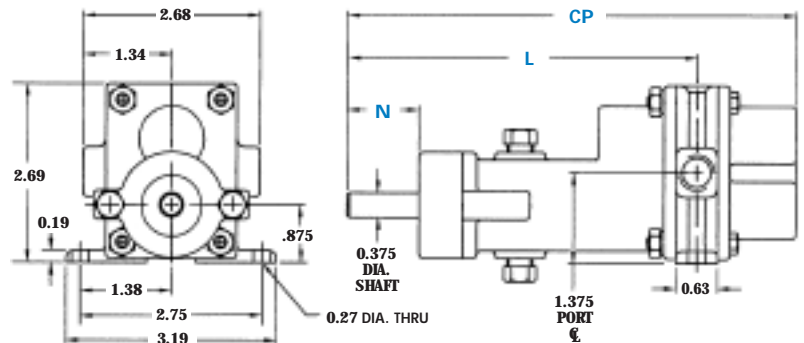

SEAL CONFIGURATIONS

DIMENSION	SINGLE & DOUBLE MECHANICAL SEALS	EXTERNAL MECHANICAL SEAL	PACKING	LIP SEAL
CP(1)	6.94	7.66	6.94	6.94
L	5.44	6.16	5.44	5.44
N	1.12	1.84	1.19(2)	1.57

NOTES: (1) Add .31 inches for Bearing Flush Plugs.
(2) Minimum dimension.

Dimensional Data (inches)

31F-MC & 31F Sealed, Close-Coupled

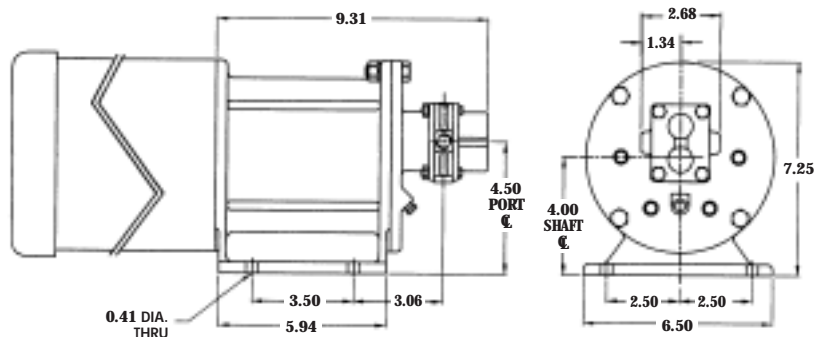

33F SEALED 33F-MC MAG-DRIVE



3 - SERIES
GEAR PUMP

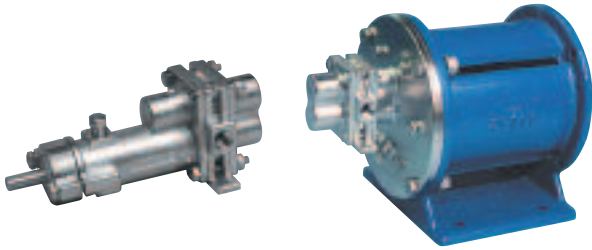

Sealed,
Long-Coupled

Sealed or Mag-Drive,
Close-Coupled

PERFORMANCE CURVES

1 CPS Fluid (Water)

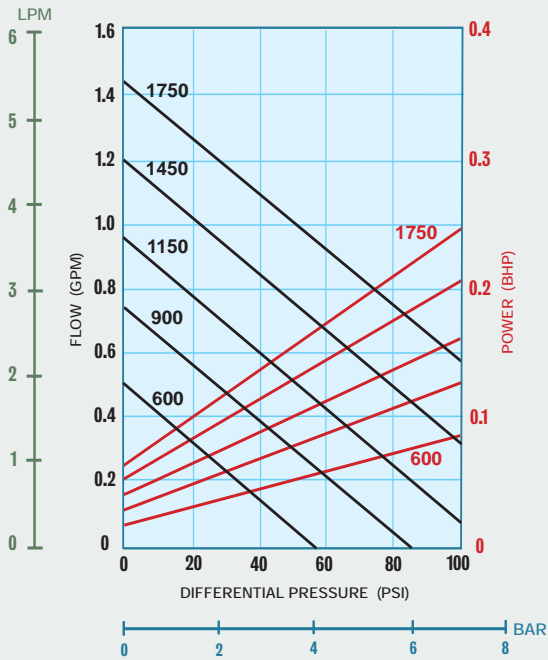

100 CPS Fluid (Oil)

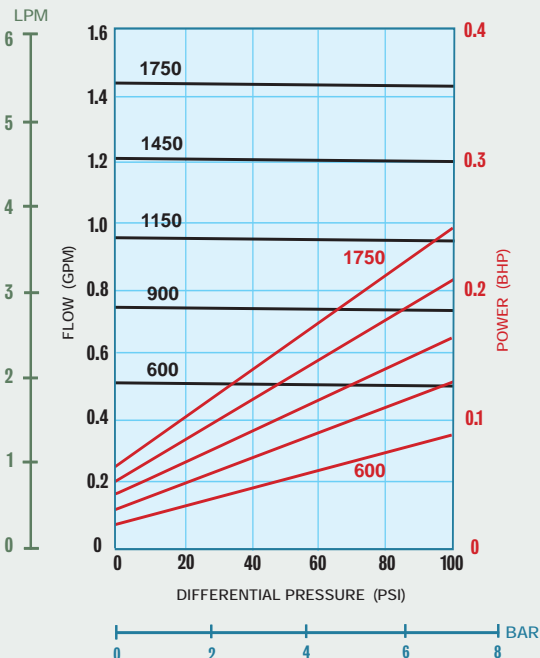

PORT SIZE	1/4" NPT/BSPT or 1/2" FLG
MAX FLOW	1.4 GPM; 5.3 LPM
MAX DIFFERENTIAL PRESSURE	100 PSI; 7 BAR
MAX DISCHARGE PRESSURE	300 PSI; 20.7 BAR
MAX TEMPERATURE	500°F; 260°C
MIN TEMPERATURE	-40°F; -40°C
MAX VISCOSITY	100,000* CPS
NPSHR @ 1750 RPM	2 FT; 0.6 M
LIFT (DRY)	1.5 FT; 0.45 M
WEIGHT (without motor)	
SEALED, Long-Coupled	2.5 LBS; 1.1 KGS
SEALED, Close-Coupled	23 LBS; 10 KGS
MAG-DRIVE, Close-Coupled	31 LBS; 14 KGS

* Higher viscosities possible. Contact factory.

Dimensional Data (inches)

33F Sealed, Long-Coupled

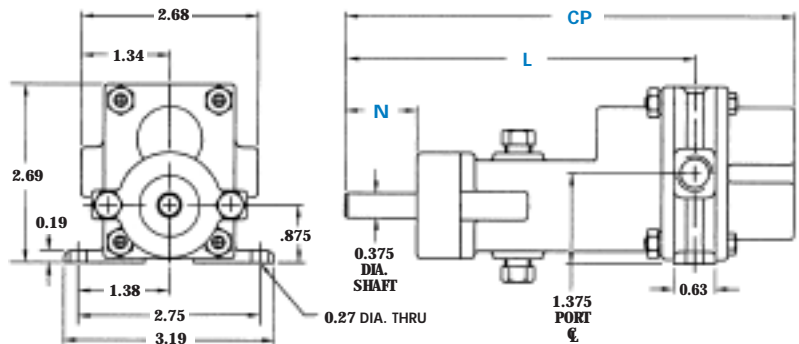

SEAL CONFIGURATIONS

DIMENSION	SINGLE & DOUBLE MECHANICAL SEALS	EXTERNAL MECHANICAL SEAL	PACKING	LIP SEAL
CP(1)	6.94	7.66	6.94	6.94
L	5.44	6.16	5.44	5.44
N	1.12	1.84	1.19(2)	1.57

NOTES: (1) Add .31 inches for Bearing Flush Plugs.
(2) Minimum dimension.

Dimensional Data (inches)

33F-MC & 33F Sealed, Close-Coupled

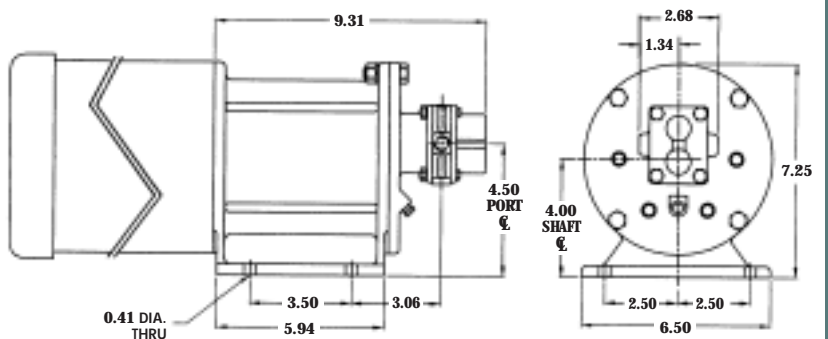

35R SEALED 35R-MC MAG-DRIVE



3 - SERIES
GEAR PUMP

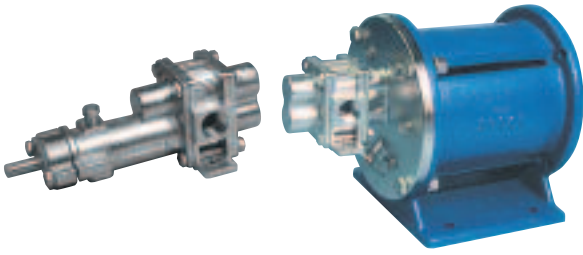

Sealed,
Long-Coupled

Sealed or Mag-Drive,
Close-Coupled

PERFORMANCE CURVES

1 CPS Fluid (Water)

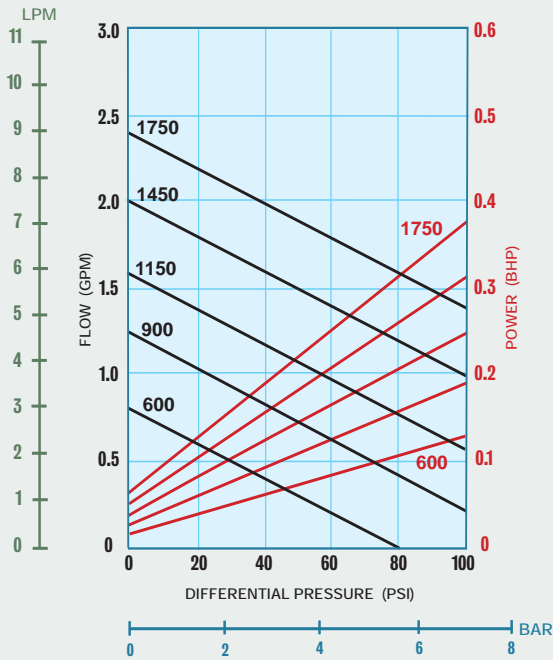

100 CPS Fluid (Oil)

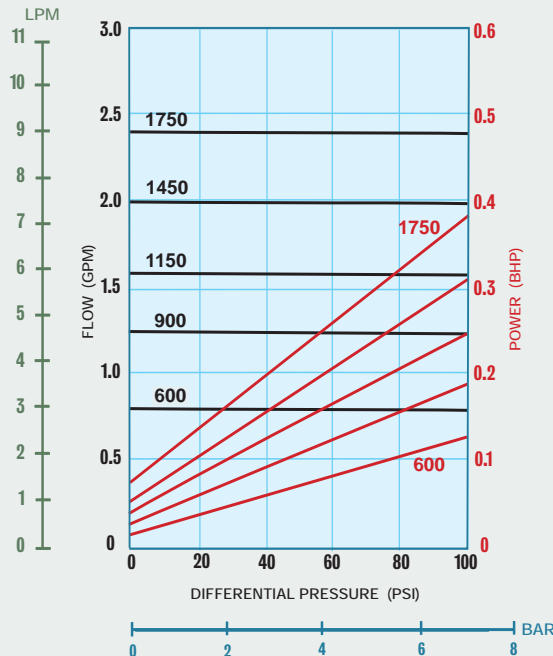

PORT SIZE	1/2" NPT/BSPT/FLG
MAX FLOW	2.4 GPM; 9.1 LPM
MAX DIFFERENTIAL PRESSURE	100 PSI; 7 BAR
MAX DISCHARGE PRESSURE	300 PSI; 20.7 BAR
MAX TEMPERATURE	500°F; 260°C
MIN TEMPERATURE	-40°F; -40°C
MAX VISCOSITY	100,000* CPS
NPSHR @ 1750 RPM	2 FT; 0.6 M
LIFT (DRY)	2 FT; 0.6 M
WEIGHT (without motor)	
SEALED, Long-Coupled	3.5 LBS; 1.6 KGS
SEALED, Close-Coupled	24 LBS; 11 KGS
MAG-DRIVE, Close-Coupled	32 LBS; 15 KGS

* Higher viscosities possible. Contact factory.

Dimensional Data (inches)

35R Sealed, Long-Coupled

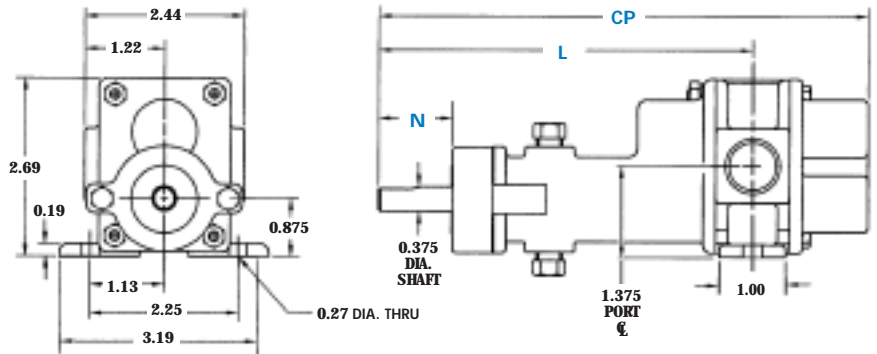

SEAL CONFIGURATIONS

DIMENSION	SINGLE & DOUBLE MECHANICAL SEALS	EXTERNAL MECHANICAL SEAL	PACKING	LIP SEAL
CP ⁽¹⁾	7.44	8.56	7.44	7.44
L	5.69	6.81	5.69	5.69
N	1.13	2.23	1.19 ⁽²⁾	1.56

NOTES: (1) Add .31 inches for Bearing Flush Plugs.
(2) Minimum dimension.

Dimensional Data (inches)

35R-MC & 35R Sealed, Close-Coupled

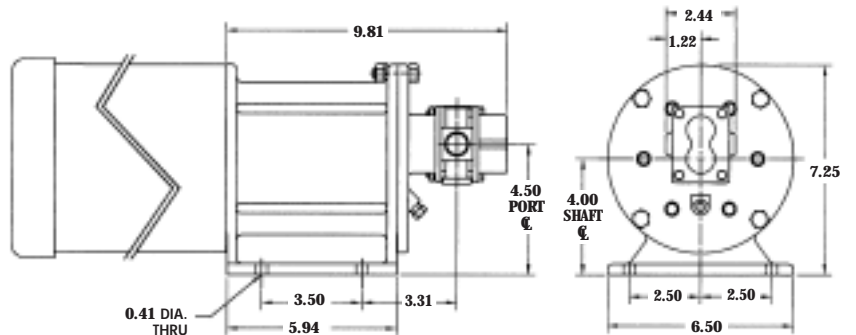

35F SEALED 35F-MC MAG-DRIVE



3 - SERIES
GEAR PUMP

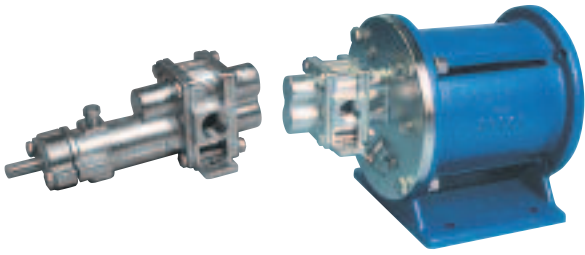

Sealed,
Long-Coupled

Sealed or Mag-Drive,
Close-Coupled

PERFORMANCE CURVES

1 CPS Fluid (Water)

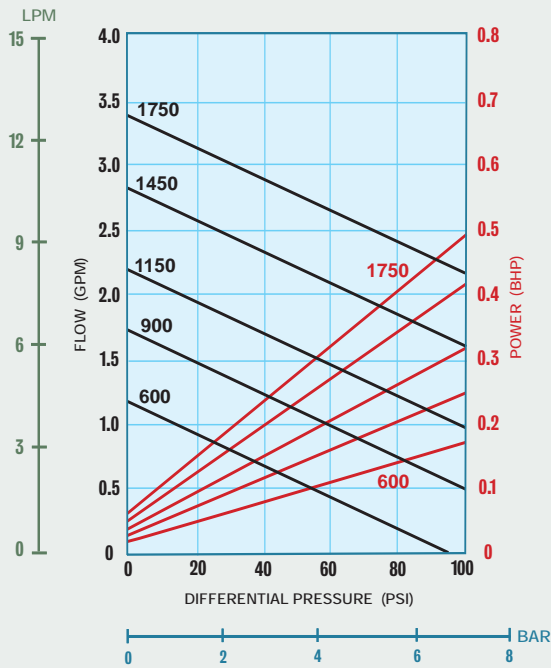

100 CPS Fluid (Oil)

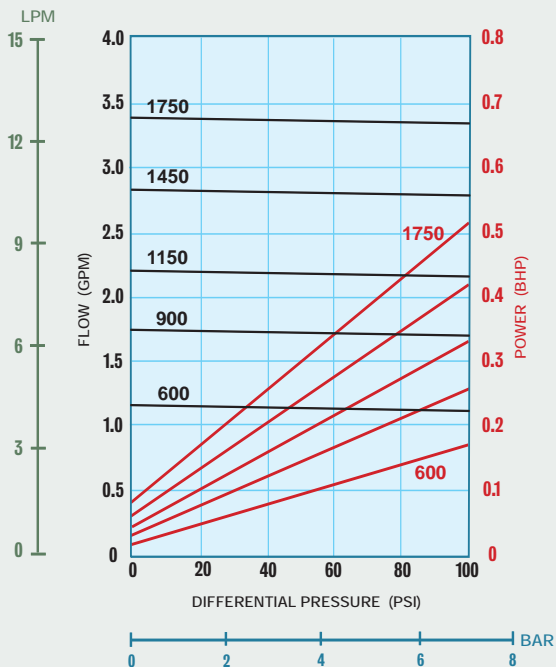

PORT SIZE	1/2" NPT/BSPT/FLG
MAX FLOW	3.4 GPM; 13 LPM
MAX DIFFERENTIAL PRESSURE	100 PSI; 7 BAR
MAX DISCHARGE PRESSURE	300 PSI; 20.7 BAR
MAX TEMPERATURE	500°F; 260°C
MIN TEMPERATURE	-40°F; -40°C
MAX VISCOSITY	100,000* CPS
NPSHR @ 1750 RPM	2 FT; 0.6 M
LIFT (DRY)	4 FT; 1.2 M
WEIGHT (without motor)	
SEALED, Long-Coupled	3.5 LBS; 1.6 KGS
SEALED, Close-Coupled	24 LBS; 11 KGS
MAG-DRIVE, Close-Coupled	32 LBS; 15 KGS

* Higher viscosities possible. Contact factory.

Dimensional Data (inches)

35F Sealed, Long-Coupled

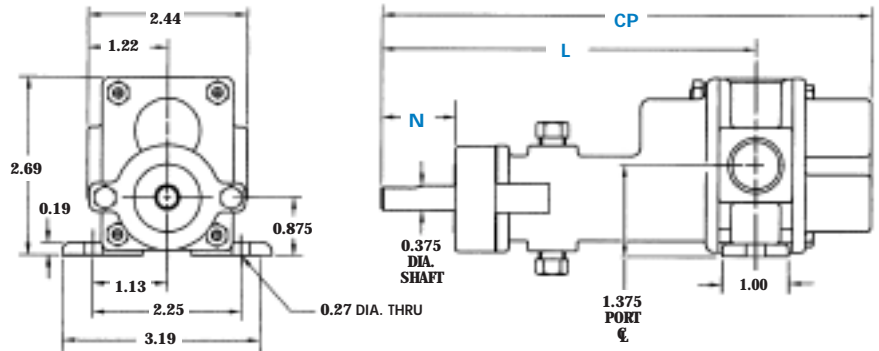

DIMENSION	SEAL CONFIGURATIONS			
	SINGLE & DOUBLE MECHANICAL SEALS	EXTERNAL MECHANICAL SEAL	PACKING	LIP SEAL
CP(1)	7.44	8.56	7.44	7.44
L	5.69	6.81	5.69	5.69
N	1.13	2.23	1.19(2)	1.56

NOTES: (1) Add .31 inches for Bearing Flush Plugs.
(2) Minimum dimension.

Dimensional Data (inches)

35F-MC & 35F Sealed, Close-Coupled

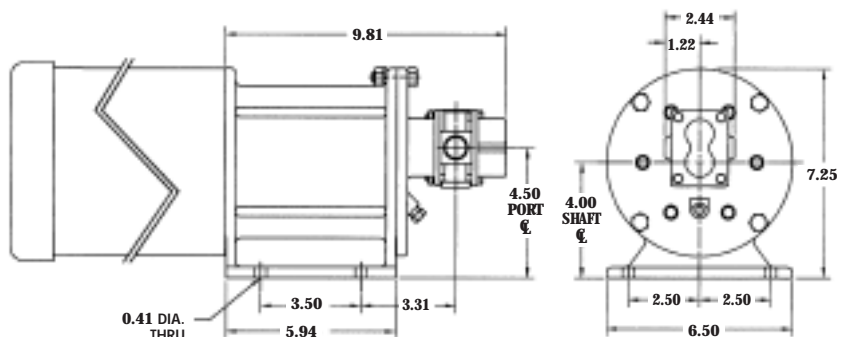

37R SEALED 37R-MC MAG-DRIVE



3 - SERIES
GEAR PUMP

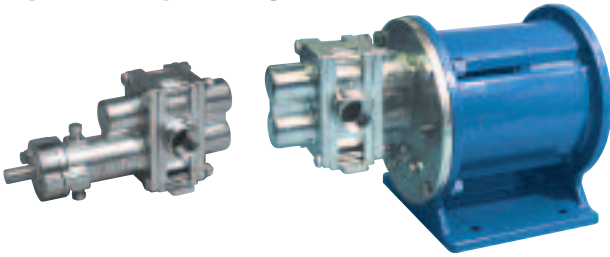

Sealed,
Long-Coupled

Sealed or Mag-Drive,
Close-Coupled

PERFORMANCE CURVES

1 CPS Fluid (Water)

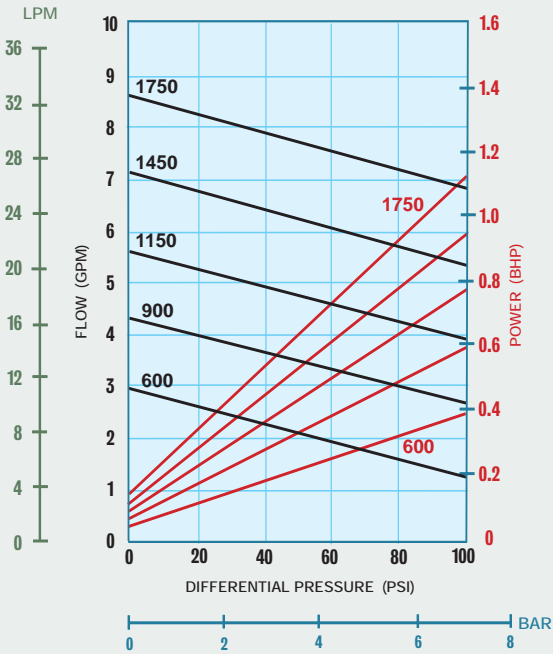

100 CPS Fluid (Oil)

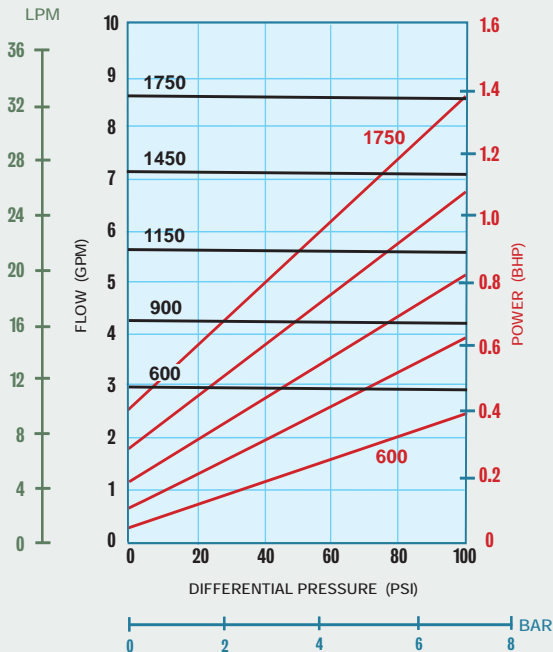

PORT SIZE	3/4" NPT/BSPT/FLG
MAX FLOW	8.6 GPM; 33 LPM
MAX DIFFERENTIAL PRESSURE	100 PSI; 7 BAR
MAX DISCHARGE PRESSURE	225 PSI; 15.5 BAR
MAX TEMPERATURE	500°F; 260°C
MIN TEMPERATURE	-40°F; -40°C
MAX VISCOSITY	100,000* CPS
NPSHR @ 1750 RPM	5.2 FT; 1.6 M
LIFT (DRY)	6 FT; 1.8 M
WEIGHT (without motor)	
SEALED, Long-Coupled	6.5 LBS; 2.9 KGS
SEALED, Close-Coupled	29 LBS; 13 KGS
MAG-DRIVE, Close-Coupled	36 LBS; 16 KGS

* Higher viscosities possible. Contact factory.

Dimensional Data (inches)

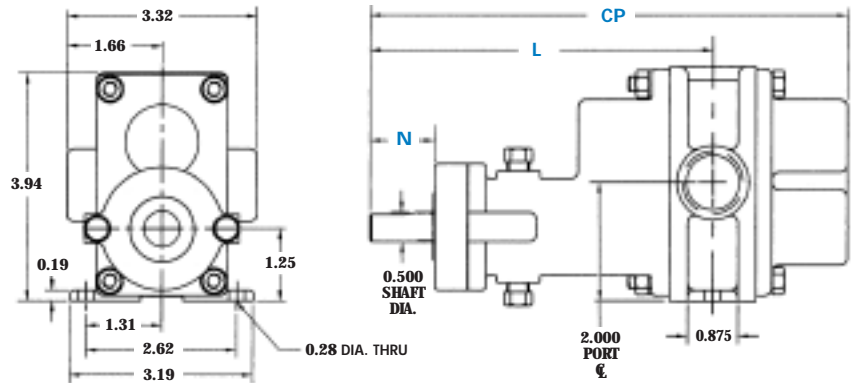

37R Sealed, Long-Coupled

DIMENSION	SEAL CONFIGURATIONS			
	SINGLE & DOUBLE MECHANICAL SEALS	EXTERNAL MECHANICAL SEAL	PACKING	LIP SEAL
CP ⁽¹⁾	8.20	10.32	8.20	8.20
L	5.98	8.10	5.98	5.98
N	1.23	3.35	1.25 ⁽²⁾	1.56

NOTES: (1) Add .31 inches for Bearing Flush Plugs.
(2) Minimum dimension.

Dimensional Data (inches)

37R-MC & 37R Sealed, Close-Coupled

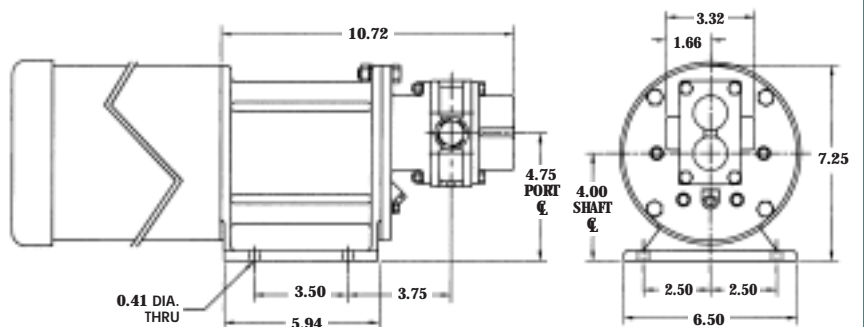

37F SEALED 37F-MC MAG-DRIVE



3 - SERIES
GEAR PUMP

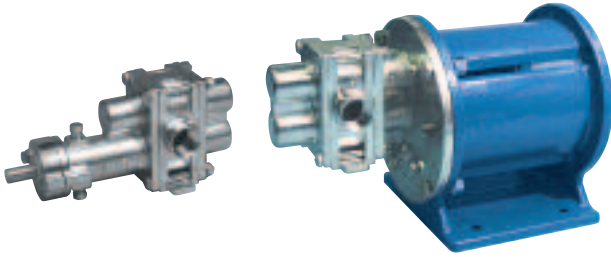

Sealed,
Long-Coupled

Sealed or Mag-Drive,
Close-Coupled

PERFORMANCE CURVES

1 CPS Fluid (Water)

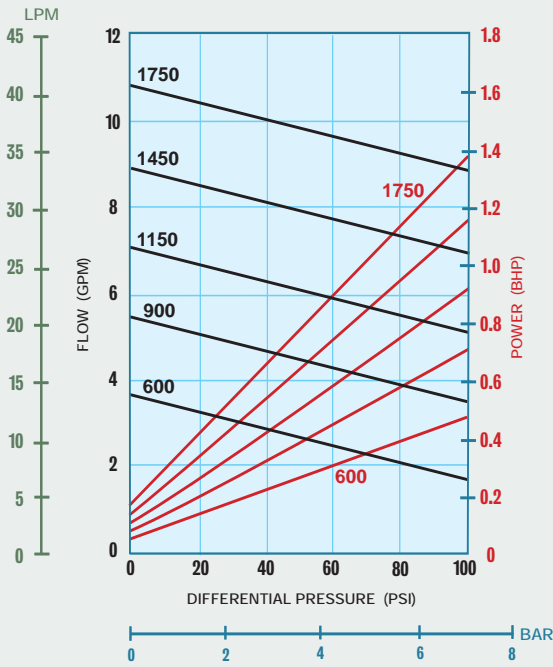

100 CPS Fluid (Oil)

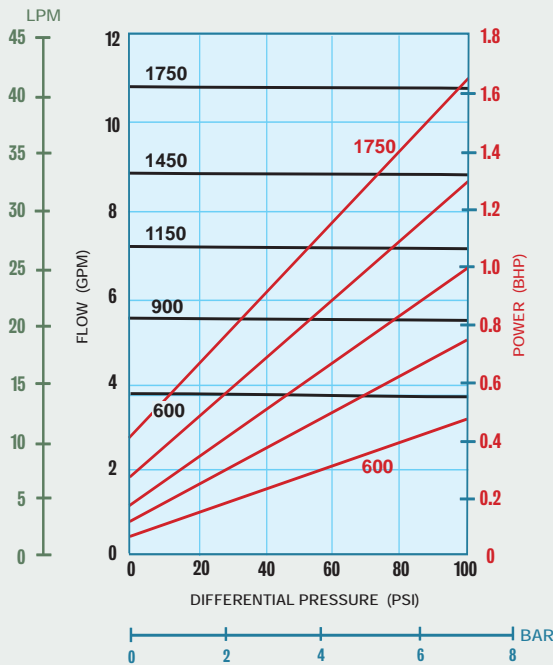

PORT SIZE	3/4" NPT/BSPT/FLG
MAX FLOW	10.7 GPM; 40.5 LPM
MAX DIFFERENTIAL PRESSURE	100 PSI; 7 BAR
MAX DISCHARGE PRESSURE	225 PSI; 15.5 BAR
MAX TEMPERATURE	500°F; 260°C
MIN TEMPERATURE	-40°F; -40°C
MAX VISCOSITY	100,000* CPS
NPSHR @ 1750 RPM	5.2 FT; 1.6 M
LIFT (DRY)	7 FT; 2.1 M
WEIGHT (without motor)	
SEALED, Long-Coupled	6.5 LBS; 2.9 KGS
SEALED, Close-Coupled	29 LBS; 13 KGS
MAG-DRIVE, Close-Coupled	36 LBS; 16 KGS

* Higher viscosities possible. Contact factory.

Dimensional Data (inches)

37F Sealed, Long-Coupled

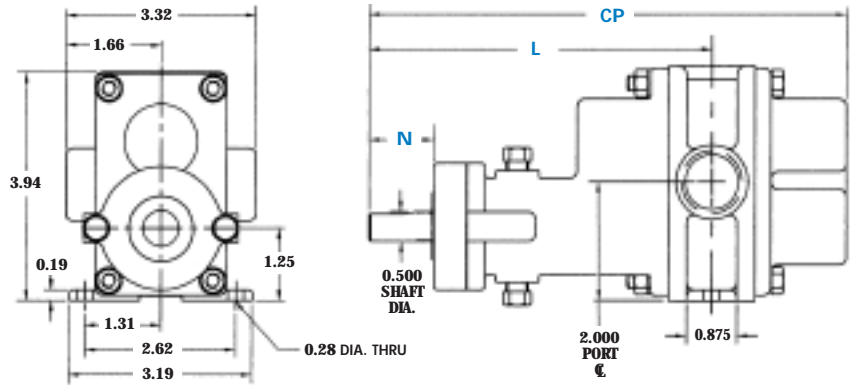

SEAL CONFIGURATIONS

DIMENSION	SINGLE & DOUBLE MECHANICAL SEALS	EXTERNAL MECHANICAL SEAL	PACKING	LIP SEAL
CP(1)	8.32	10.44	8.32	8.32
L	5.98	8.10	5.98	5.98
N	1.11	3.23	1.13(2)	1.44

NOTES: (1) Add .31 inches for Bearing Flush Plugs.
(2) Minimum dimension.

Dimensional Data (inches)

37F-MC & 37F Sealed, Close-Coupled

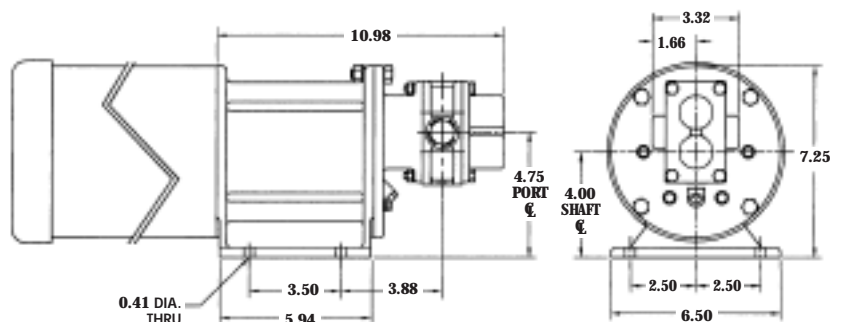

39R SEALED 39R-MC MAG-DRIVE



3 - SERIES
GEAR PUMP

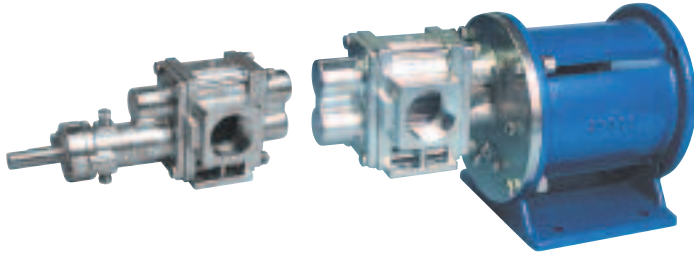

Sealed,
Long-Coupled

Sealed or Mag-Drive,
Close-Coupled

PERFORMANCE CURVES

1 CPS Fluid (Water)

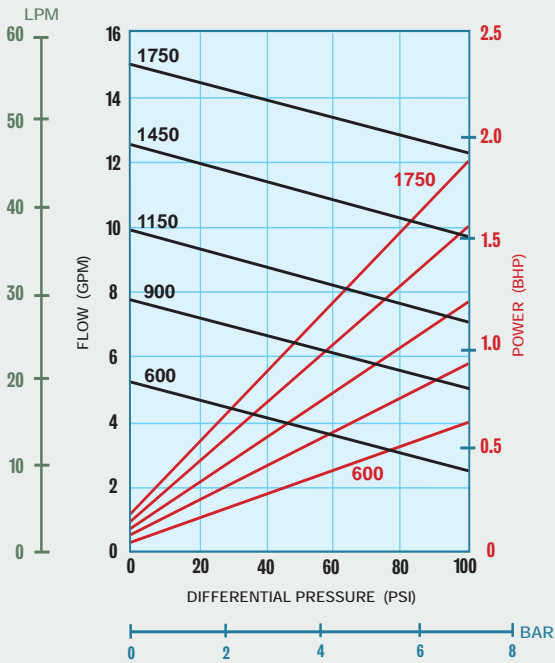

100 CPS Fluid (Oil)

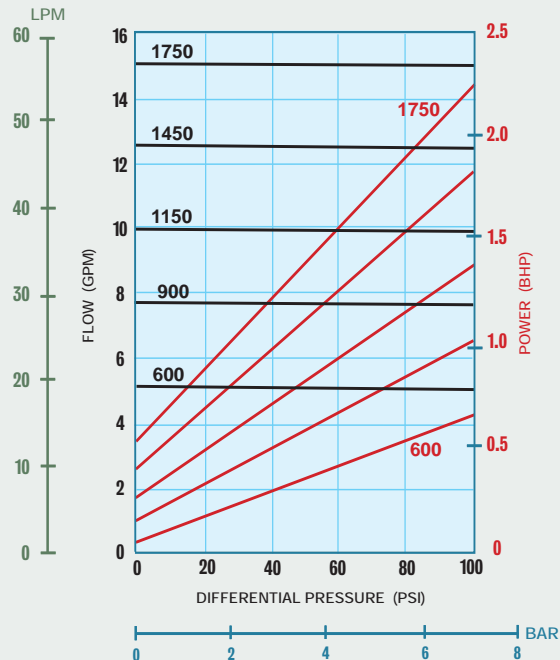

PORT SIZE 1" NPT/BSPT/FLG

MAX FLOW 15 GPM; 57 LPM

MAX DIFFERENTIAL PRESSURE 100 PSI; 7 BAR

MAX DISCHARGE PRESSURE 225 PSI; 15.5 BAR

MAX TEMPERATURE 500°F; 260°C

MIN TEMPERATURE -40°F; -40°C

MAX VISCOSITY 100,000* CPS

NPSHR @ 1750 RPM 4 FT; 1.2 M

LIFT (DRY) 6 FT; 1.8 M

WEIGHT (without motor)

SEALED, Long-Coupled

8 LBS; 3.6 KGS

SEALED, Close-Coupled

34 LBS; 15 KGS

MAG-DRIVE, Close-Coupled

38 LBS; 17 KGS

* Higher viscosities possible. Contact factory.

Dimensional Data (inches)

39R Sealed, Long-Coupled

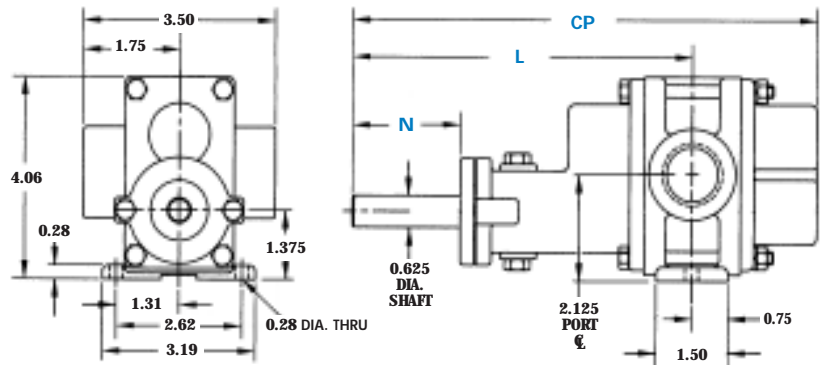

DIMENSION	SEAL CONFIGURATIONS	
	SINGLE & DOUBLE MECHANICAL SEALS	PACKING
CP(1)	9.68	9.68
L	7.08	7.08
N	2.00	2.00 (2)

NOTES: (1) Add .31 inches for Bearing Flush Plugs.
(2) Minimum dimension.

Dimensional Data (inches)

39R-MC & 39R Sealed, Close-Coupled

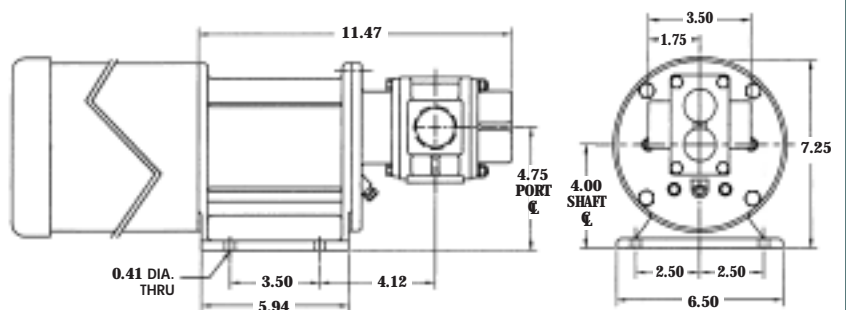

39F SEALED 39F-MC MAG-DRIVE



3 - SERIES
GEAR PUMP

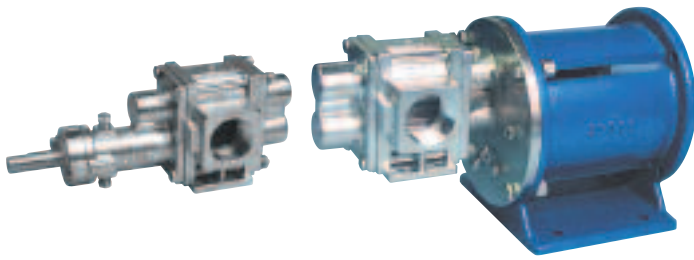

Sealed,
Long-Coupled

Sealed or Mag-Drive,
Close-Coupled

PERFORMANCE CURVES

1 CPS Fluid (Water)

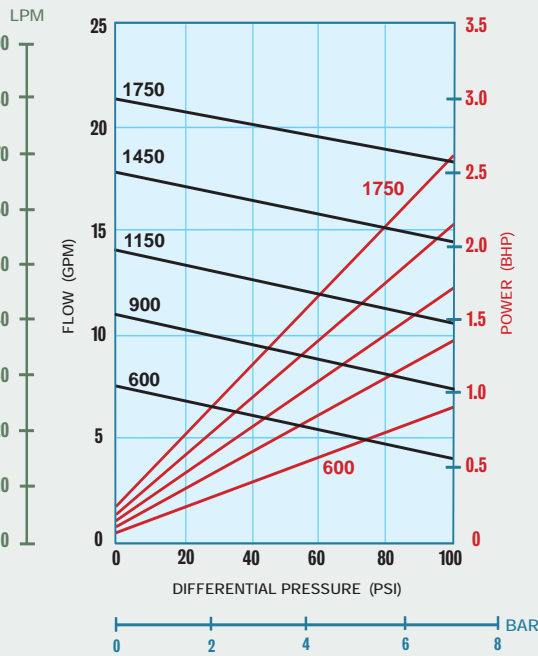

100 CPS Fluid (Oil)

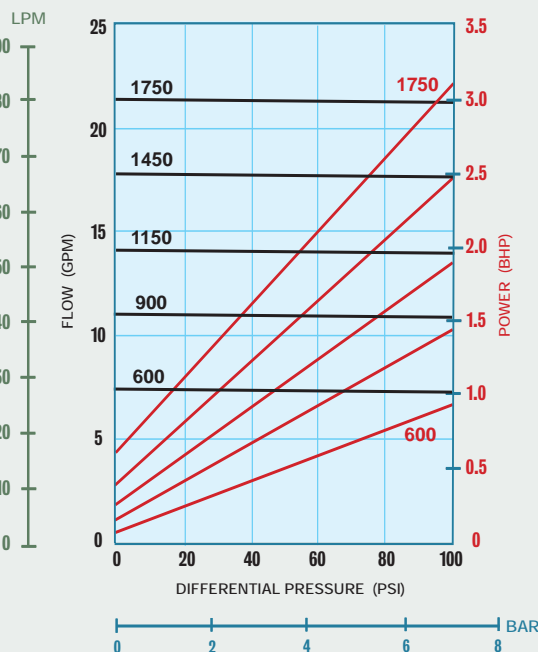

PORT SIZE	1 1/4" NPT/BSPT/FLG
MAX FLOW	21.5 GPM; 81.4 LPM
MAX DIFFERENTIAL PRESSURE	100 PSI; 7 BAR
MAX DISCHARGE PRESSURE	225 PSI; 15.5 BAR
MAX TEMPERATURE	500°F; 260°C
MIN TEMPERATURE	-40°F; -40°C
MAX VISCOSITY	100,000* CPS
NPSHR @ 1750 RPM	3 FT; 0.9 M
LIFT (DRY)	14 FT; 4.2 M
WEIGHT (without motor)	
SEALED, Long-Coupled	10 LBS; 4.5 KGS
SEALED, Close-Coupled	36 LBS; 16 KGS
MAG-DRIVE, Close-Coupled	40 LBS; 18 KGS

* Higher viscosities possible. Contact factory.

Dimensional Data (inches)

39F Sealed, Long-Coupled

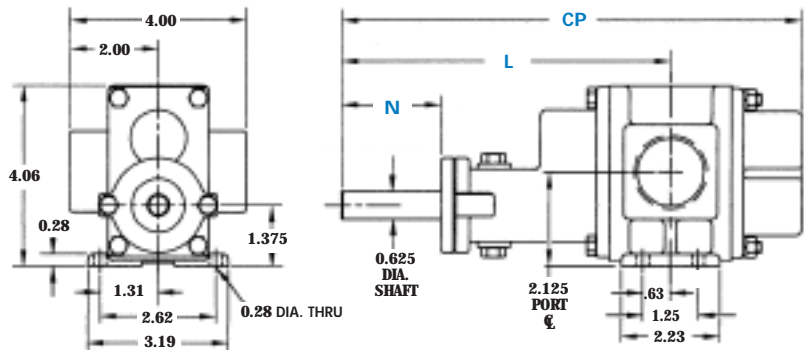

SEAL CONFIGURATIONS

DIMENSION	SINGLE & DOUBLE MECHANICAL SEALS	PACKING
CP(1)	10.44	10.44
L	7.47	7.47
N	2.00	2.00 (2)

NOTES: (1) Add .31 inches for Bearing Flush Plugs.
(2) Minimum dimension.

Dimensional Data (inches)

39F-MC & 39F Sealed, Close-Coupled

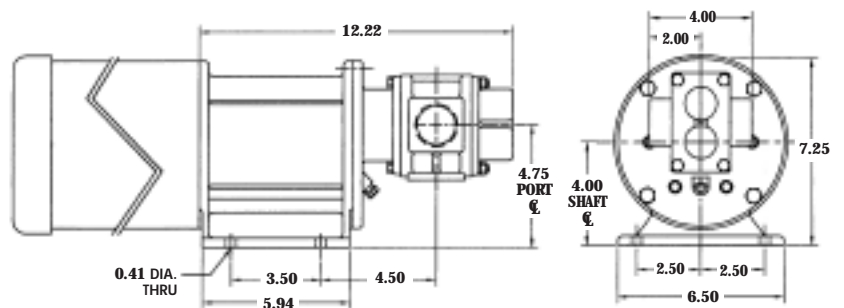

312R SEALED 312R-MC MAG-DRIVE



3 - SERIES
GEAR PUMP

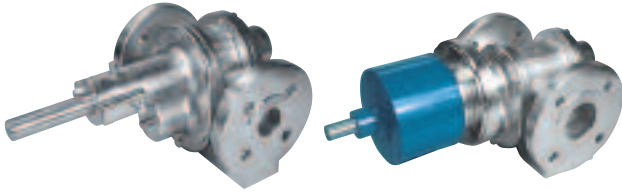

Sealed,
Long-Coupled

Mag-Drive,
Long-Coupled

PERFORMANCE CURVES

1 CPS Fluid (Water)

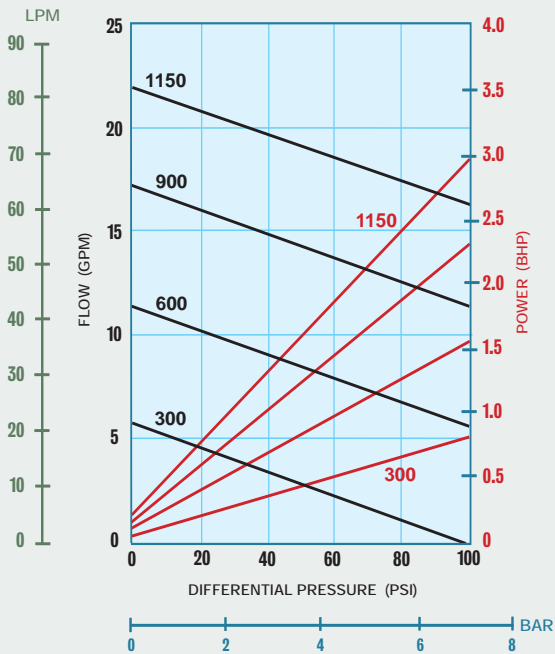

100 CPS Fluid (Oil)

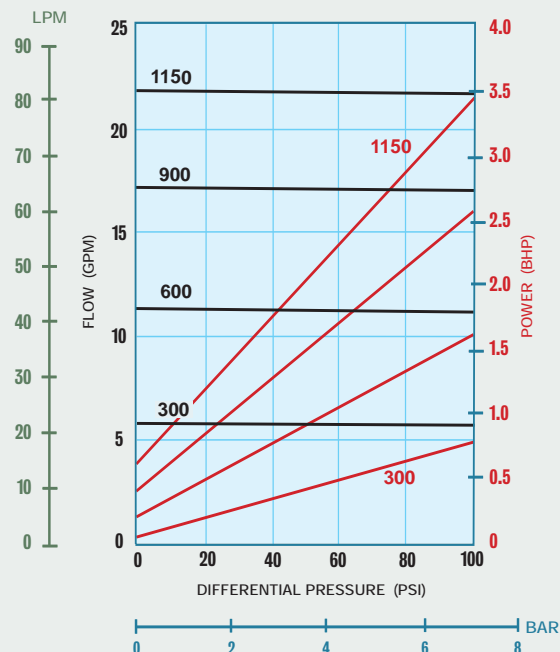

PORT SIZE	1 1/2" FLG or 1 1/4" NPT/BSPT
MAX. FLOW	22 GPM; 83 LPM
MAX DIFFERENTIAL PRESSURE	100 PSI; 7 BAR
MAX DISCHARGE PRESSURE	270 PSI; 18.6 BAR
MAX TEMPERATURE	500°F; 260°C
MIN TEMPERATURE	-40°F; -40°C
MAX VISCOSITY	100,000* CPS
NPSHR @ 1150 RPM	5 FT; 1.5 M
LIFT (DRY)	15 FT; 4.5 M
WEIGHT (without motor)	
SEALED, Long-Coupled	52 LBS; 24 KGS
MAG-DRIVE, Long-Coupled	70 LBS; 32 KGS

* Higher viscosities possible. Contact factory.

Dimensional Data (inches)

312R Sealed, Long-Coupled

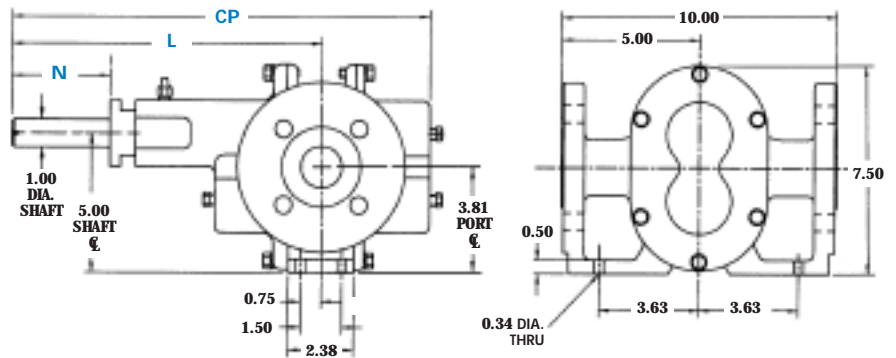

SEAL CONFIGURATIONS

DIMENSION	SINGLE & DOUBLE MECHANICAL SEALS	PACKING
CP(1)	15.19	15.19
L	11.25	11.25
N	4.06	3.78 (2)

NOTES: (1) Add .31 inches for Bearing Flush Plugs.
(2) Minimum dimension.

Dimensional Data (inches)

312R-MC, Long-Coupled

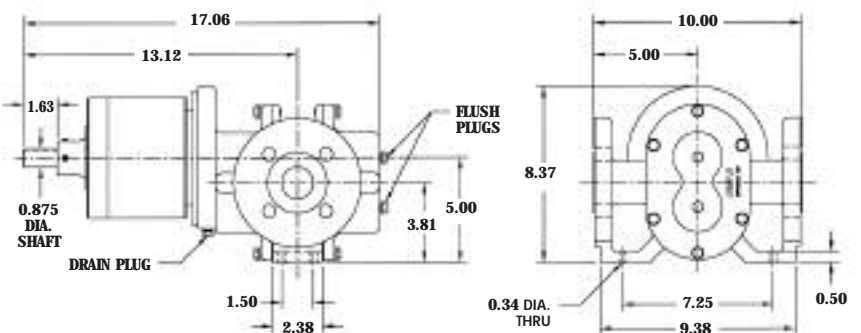

314F SEALED 314F-MC MAG-DRIVE



3 - SERIES
GEAR PUMP

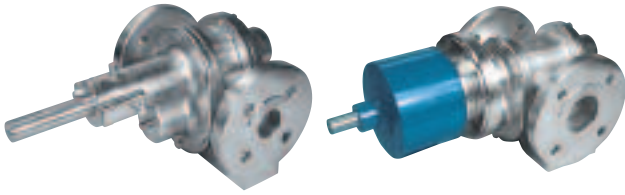

Sealed,
Long-Coupled

Mag-Drive,
Long-Coupled

PERFORMANCE CURVES

1 CPS Fluid (Water)

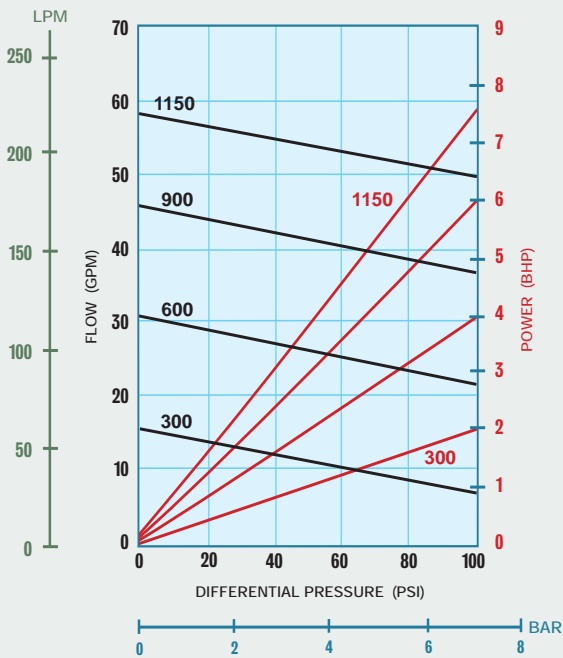

100 CPS Fluid (Oil)

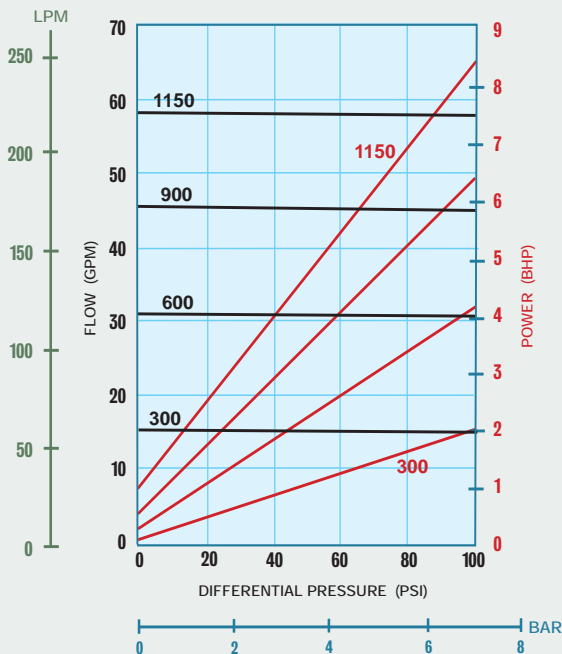

PORT SIZE	2 1/2" FLG
MAX FLOW	58 GPM; 220 LPM
MAX DIFFERENTIAL PRESSURE	100 PSI; 7 BAR
MAX DISCHARGE PRESSURE	270 PSI; 18.6 BAR
MAX TEMPERATURE	500°F; 260°C
MIN TEMPERATURE	-40°F; -40°C
MAX VISCOSITY	100,000* CPS
NPSHR @ 1150 RPM	3 FT; 0.9 M
LIFT (DRY)	20 FT; 6.1 M
WEIGHT (without motor)	
SEALED, Long-Coupled	67 LBS; 30 KGS
MAG-DRIVE, Long-Coupled	85 LBS; 39 KGS

* Higher viscosities possible. Contact factory.

Dimensional Data (inches)

314F Sealed, Long-Coupled

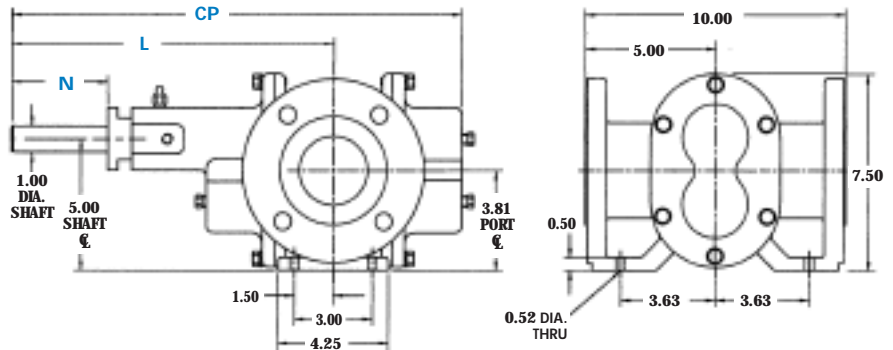

SEAL CONFIGURATIONS

DIMENSION	SINGLE & DOUBLE MECHANICAL SEALS	PACKING
CP(1)	17.19	17.19
L	12.25	12.25
N	4.06	3.78 (2)

NOTES: (1) Add .31 inches for Bearing Flush Plugs.
(2) Minimum dimension.

Dimensional Data (inches)

314F-MC, Long-Coupled

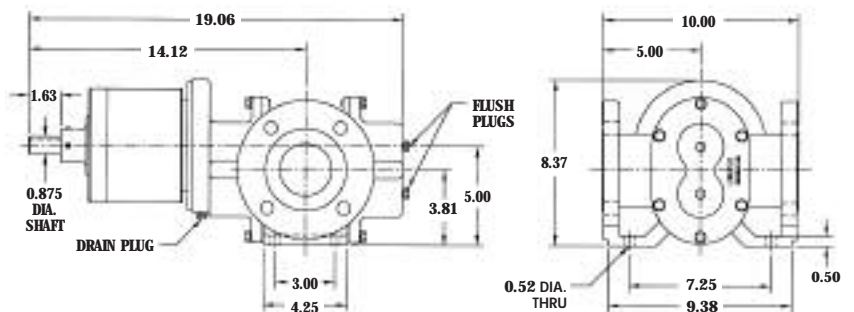

2-SERIES, 4-SERIES & MAX-SERIES
LIQUIFLO EXTERNAL GEAR PUMPS

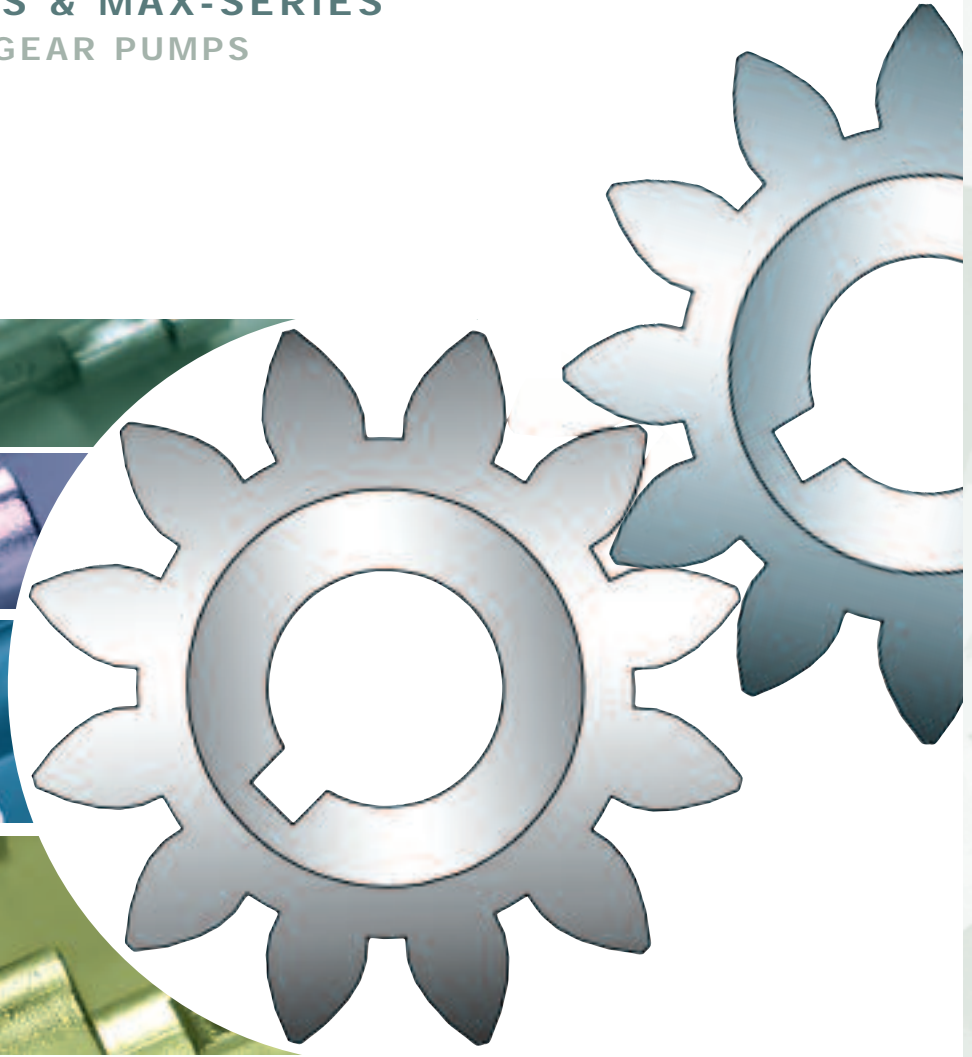
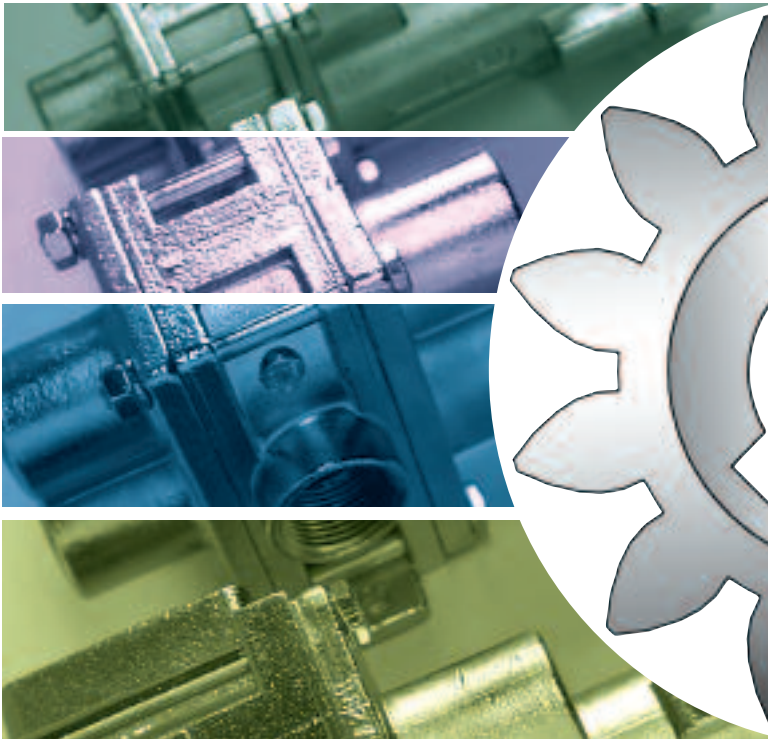

2-SERIES ULTRA LOW-FLOW GEAR PUMP MAG-DRIVE MINI PUMP

GENERAL INFORMATION

DESCRIPTION

The **2-Series Mini-Pump** is a low-flow external gear pump that is completely field repairable. With a ruggedly designed 316 Stainless Steel body and several material options for shafts, gears, wear plates and bearings, these pumps can be used in a wide variety of services.

TYPICAL USES & APPLICATIONS

The **2-Series Mini-Pump** is typically used in chemical processing plants, pilot plants, laboratories, paper-making, chemical dosing and metering, pipeline sampling and wastewater treatment.

MAINTENANCE

The **2-Series Mini-Pump** was designed with reliability and ease of maintenance in mind. The gear and shaft are permanently fixed to each other making repairs easy and fool-proof. Standard repair kits contain all wearing parts and static O-rings:

- Gear-Shaft Assemblies
- Bearing-Wear Plate Combinations
- O-rings

CUSTOMIZATION

Contact factory.

FEATURES

- Mag-Drive
- Corrosion resistant materials
- Pulseless flow
- Flow rates from 1 to 30 GPH
- Differential pressures up to 225 PSI
- Viscosities to 5,000 CPS
- Low NIPR (NPSHR)
- Self-compensating wear plates limit slip on low viscosity fluids
- SmCo Magnets
- Minutes to repair

REPAIR KITS

Repair Kits simplify inventory and speed repair. All parts can also be purchased separately.



2-Series Mini-Pump close-coupled to motor

MATERIALS AVAILABLE

HOUSINGS	GEARS	WEAR PLATES/ BEARINGS	SHAFTS
316 SS	316 SS	Carbon 60	316 SS
	Alloy-C	PEEK	TC-Coated
	PEEK		CO-Coated

Note: For information on the above materials, refer to the Engineering section, pages 132-135.

Dimensional Data - inches (mm)

2-SERIES Mag-Drive Mini Pump

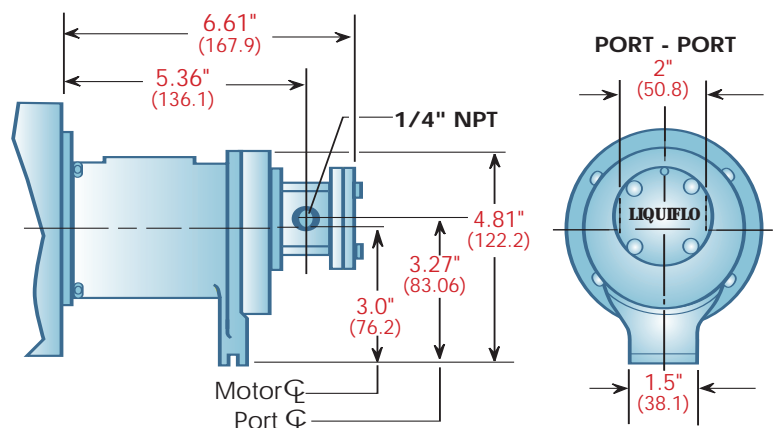

Liquiflo 2-Series Gear Pumps
Selection & Availability

EXAMPLE:

2FS6PE200X, designates a Model 2F Mag-Drive Pump.

2 F S 6 P E 2 0 0 X
1 & 2 3 4 5 6 7 8 9 10

Pos.	Description	Selection
1 & 2	Pump Model	2E 2F Pump
3	Housing Mat'l	S 316 SS NPT
4	Drive Gear Mat'l	6 316 SS
5	Idler Gear Mat'l	P PEEK
6	Wear Plates/Bearings	E Carbon 60
7	Outer Magnet Bore	2 .625" (56C motor)
8	Shafts	Q Non-coated
9	O-Rings	0 Teflon
10	Magnetic Coupling	X MCX

Liquiflo's Model Code describes both the pump's size and materials selected. This model code is required for the future identification of your pump when reordering either a pump or replacement parts. Model code is permanently stamped into pump housing.

- Available
- ⊗ Not Available
- CF Contact Factory



Sample Model No. **2 F S 6 P E 2 0 0 X**
Position No. 1 2 3 4 5 6 7 8 9 10

Position 1 Model	Pump Model	2
Position 2 Model	F = Full Capacity R = Reduced Capacity	■ ■
Position 3 Basic Material & Port Type	S = 316 SS NPT X = 316 SS BSPT	■ ■
Position 4 Drive Gear	1 = Alloy-C 6 = 316 SS P = PEEK	■ ■ ■
Position 5 Idler Gear	1 = Alloy-C 6 = 316 SS P = PEEK	■ ■ ■
Position 6 Wear Plates & Bearings Combination	E = Carbon 60 P = PEEK	■ ■
Position 7 Outer Magnet Bore (Motor Frame)	0 = 0.500" (NEMA 48C) 1 = 14 mm (IEC 71 - B14 Face) 2 = 0.625" (NEMA 56C/56HC)	■ ■ ■
Position 8 Shafts	0 = 316 SS (uncoated) 1 = 316 SS - Chrome Oxide Coated 2 = 316 SS - Tungsten Carbide Coated	■ ■ ■
Position 9 O-Rings	0 = Teflon V = Viton K = Kalrez	■ ■ ■
Position 10 Magnetic Coupling	X = 10 in-lbs	■
Suffix Trim Option	- 8 = Temperature Trim	■

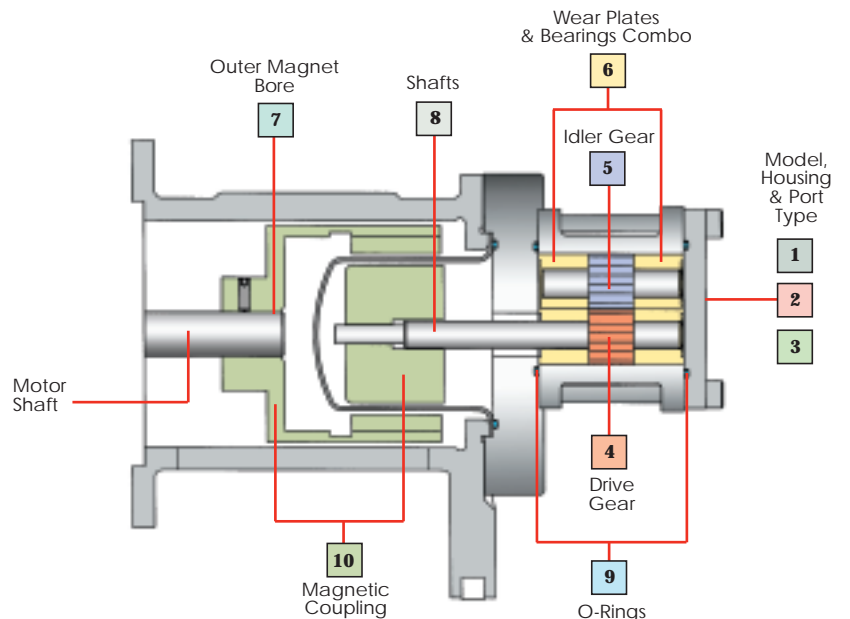

2-Series Mag-Drive Gear Pump

2-SERIES Mag-Drive Mini Pump

2-SERIES
GEAR PUMP

MODEL	2R (Reduced)	2F (Full)
PORT SIZE	1/4" NPT/BSPT	1/4" NPT/BSPT
MAX FLOW	17 GPH; 64 LPH	32.5 GPH; 123 LPH
MAX DIFFERENTIAL PRESSURE	225 PSI; 15.5 BAR	225 PSI; 15.5 BAR
MAX DISCHARGE PRESSURE	300 PSI; 20.7 BAR	300 PSI; 20.7 BAR
MAX TEMPERATURE	500°F; 260°C	500°F; 260°C
MIN TEMPERATURE	-40°F; -40°C	-40°F; -40°C
MAX VISCOSITY (300 RPM)	5,000 CPS	5,000 CPS
NPSHR @ 1750 RPM	3 FT; 0.9 M	3 FT; 0.9 M
LIFT (DRY)	negligible	negligible
WEIGHT (without motor)	5 LBS; 2.3 KGS	5 LBS; 2.3 KGS

PERFORMANCE CURVES

2R 10 CPS Fluid (Oil)

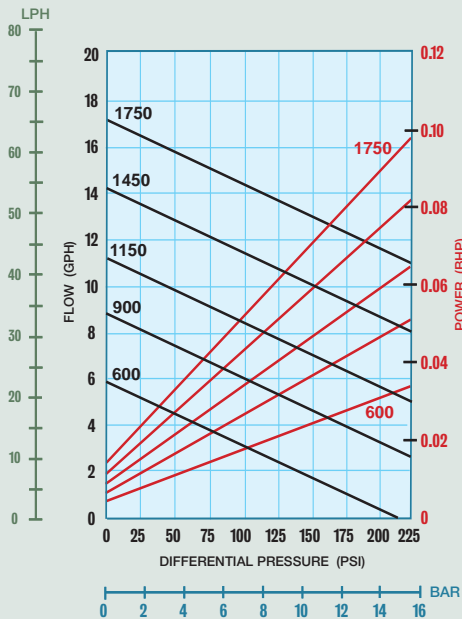

2F 10 CPS Fluid (Oil)

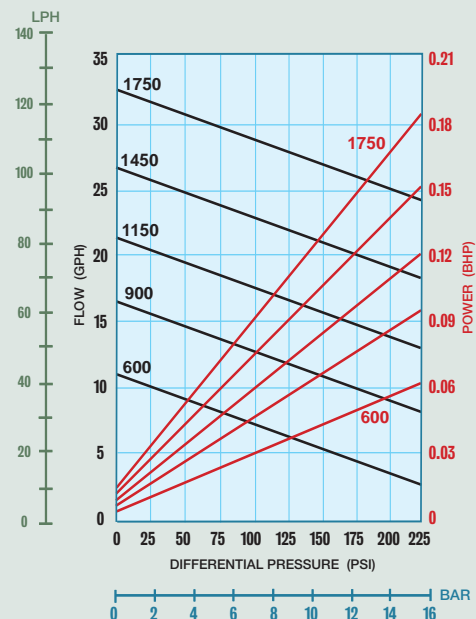

100 CPS Fluid (Oil)

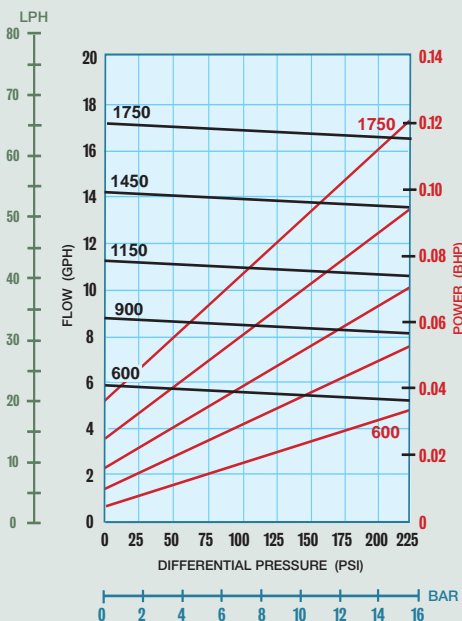

100 CPS Fluid (Oil)

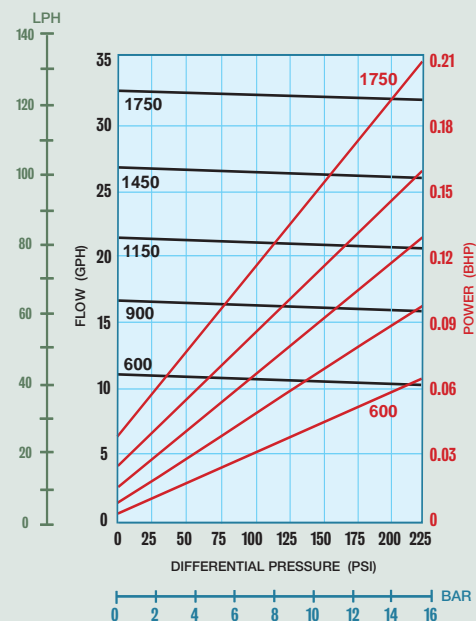

4-SERIES LOW-FLOW GEAR PUMP MAG-DRIVE

GENERAL INFORMATION

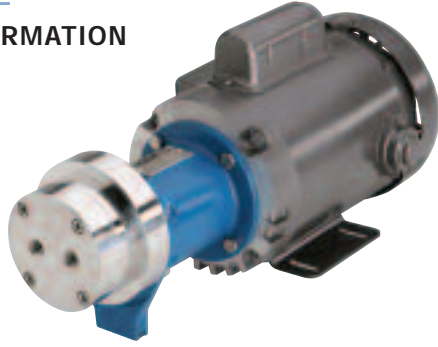

Liquiflo's **4-Series** pumps are low-flow magnetically-driven external gear pumps that are completely field repairable. The 4-Series housings are manufactured from Bar Stock in 316 Stainless Steel, Alloy-C or Titanium. With several material options for shafts, gears, wear plates and bearings, these pumps can be used in a wide variety of chemical processing applications.



REPAIR KITS

Repair Kits simplify inventory and speed repair. All parts can also be purchased separately.

MATERIALS AVAILABLE

HOUSINGS	GEARS	WEAR PLATES	BEARINGS	SHAFTS
316 SS	316 SS	Carbon 60	Carbon 60	316 SS
Alloy-C	Alloy-C	Silicon Carbide	Silicon Carbide	Alloy-C
Titanium	Titanium	PEEK	PEEK	TC-Coated
	PEEK	Teflon	Teflon	CO-Coated
	Ryton			Titanium, TO-Coated
	Teflon			

Note: For information on the above materials, refer to the Engineering section, pages 132-135.

COMPOSITE GEAR PUMP PERFORMANCE CURVES

TEST FLUID: WATER
(1 CPS)

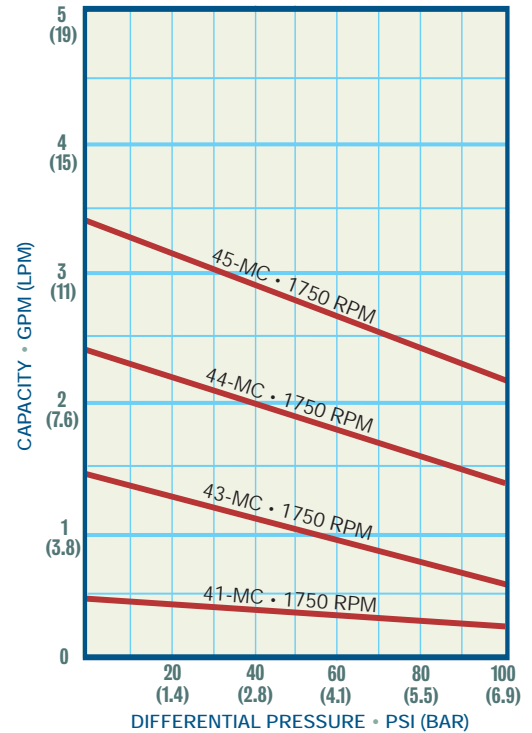

Dimensional Data - inches [mm]

4-SERIES Low-Flow Mag-Drive Gear Pump

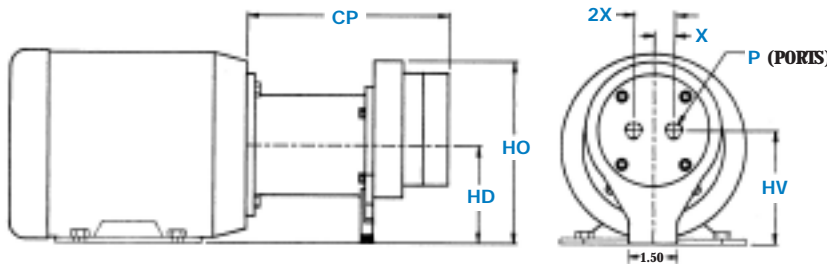

PUMP MODELS	MOTOR FRAME	CP	HD	HO	HV	X	2X	P	
								NPT	BSPT
41 & 43	IEC71-B14	5.93 [151]	2.80 [71.1]	5.40 [137]	3.30 [83.8]	0.75 [19]	1.50 [38.1]	1/4"	3/8"
	NEMA 48C	6.30 [160]	3.00 [76.2]	5.60 [142]	3.50 [88.9]	0.75 [19]	1.50 [38.1]	1/4"	3/8"
	NEMA 56C	6.67 [169]	3.50 [88.9]	6.10 [155]	4.00 [102]	0.75 [19]	1.50 [38.1]	1/4"	3/8"
44 & 45	IEC71-B14	6.43 [163]	2.80 [71.1]	5.40 [137]	3.30 [83.8]	0.75 [19]	1.50 [38.1]	3/8"	3/8"
	NEMA 48C	6.80 [173]	3.00 [76.2]	5.60 [142]	3.50 [88.9]	0.75 [19]	1.50 [38.1]	3/8"	3/8"
	NEMA 56C	7.17 [182]	3.50 [88.9]	6.10 [155]	4.00 [102]	0.75 [19]	1.50 [38.1]	3/8"	3/8"

PUMP MODEL CODING

EXAMPLE:

43S6PEEN200, designates a Model 43 Mag-Drive Pump.

43 S 6 P E E N 2 0 0
 1 2 3 4 5 6 7 8 9 10

Pos.	Description	Selection
1	Pump Model	43 43 Pump
2	Housing Mat'l	S 316 SS NPT
3	Drive Gear Mat'l	P 316 SS
4	Idler Gear Mat'l	E PEEK
5	Wear Plate Mat'l	E Carbon 60
6	Bearing Mat'l	E Carbon 60
7	Magnetic Coupling	N MCN
8	Outer Magnet Bore	2 .625" (56C motor)
9	Shafts	0 Non-coated
10	Motor	0 None

Liquiflo's Model Code describes both the pump's size and materials selected. This model code is required for the future identification of your pump when reordering either a pump or replacement parts. Model code is permanently stamped into pump housing.

- Available
- ⊗ Not Available
- CF Contact Factory



Liquiflo 4-Series Gear Pumps Selection & Availability



Sample Model No. **43 S 6 P E E N 2 0 0**
 Position No. 1 2 3 4 5 6 7 8 9 10

Position	Description	41	43	44	45
1	Pump Model	■	■	■	■
2	Basic Material & Port Type	■	■	■	■
	S = 316 SS NPT	■	■	■	■
	X = 316 SS BSPT	■	■	■	■
	H = Alloy-C NPT	■	■	■	■
	Y = Alloy-C BSPT	■	■	■	■
	T = Titanium NPT	■	■	■	■
	Z = Titanium BSPT	■	■	■	■
3	Drive Gear	■	■	■	■
	1 = Alloy-C	■	■	■	■
	3 = Teflon	■	■	■	■
	4 = Titanium	■	■	■	■
	6 = 316 SS	■	■	■	■
	P = PEEK	■	■	■	■
4	Idler Gear	■	■	■	■
	1 = Alloy-C	■	■	■	■
	3 = Teflon	■	■	■	■
	4 = Titanium	■	■	■	■
	6 = 316 SS	■	■	■	■
	8 = Ryton	■	■	■	■
	P = PEEK	■	■	■	■
5	Wear Plates	■	■	■	■
	3 = Teflon	■	■	■	■
	4 = Ceramic (SiC)	■	■	■	■
	E = Carbon 60	■	■	■	■
	P = PEEK	■	■	■	■
6	Bearings	■	■	■	■
	3 = Teflon	■	■	■	■
	B = Silicon Carbide	■	■	■	■
	E = Carbon 60	■	■	■	■
	P = PEEK	■	■	■	■
7	Magnetic Coupling	■	■	■	■
	N = 20 in-lbs	■	■	■	■
	R = 30 in-lbs	■	■	■	■
8	Outer Magnet Bore (Motor Frame)	■	■	■	■
	0 = .500" (NEMA 48C)	■	■	■	■
	1 = 14 mm (IEC 71 - B14 Face)	■	■	■	■
	2 = .625" (NEMA 56C/56HC)	■	■	■	■
9	Shafts	■	■	■	■
	0 = Material Same as Housing (uncoated)*	■	■	■	■
	A = Chrome Oxide Coated	■	■	■	■
	C = Tungsten Carbide Coated	■	■	■	■
10	Motor	■	■	■	■
	0 = No Motor	■	■	■	■
	A = 0.25 Hp/1750 RPM - TEFC-AC	■	■	■	■
	B = 0.25 Hp/1150 RPM - TEFC-AC	■	■	■	■
	C = 0.25 Hp/1750 RPM - TENV-DC w/ SCR Control	■	■	■	■
Suffix	Trim Options	■	■	■	■
	- 8 = Temperature Trim	■	■	■	■
	- 9D = Viscosity Trim (double clearance)	■	■	■	■
	- 9T = Viscosity Trim (triple clearance)	■	■	■	■

* Titanium pumps have TiO₂-Coated Shafts as standard

- 8 Outer Magnet Bore Size (not shown)
- 9 Shafts (not shown)
- 10 Motor (not shown)

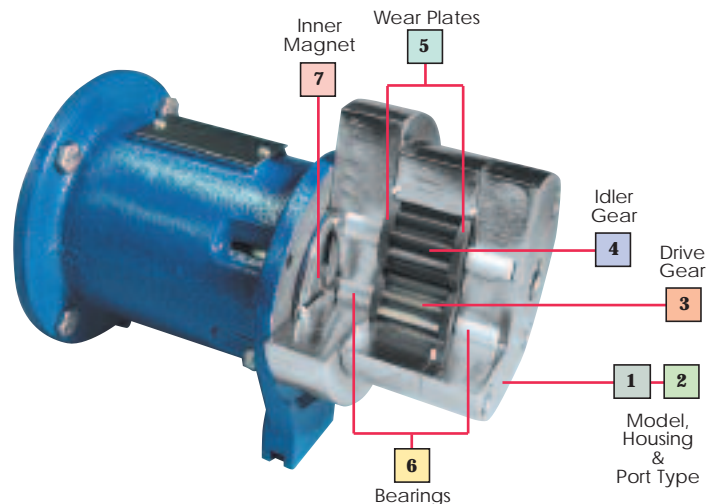

4-Series Mag-Drive Gear Pump

4-SERIES MAG-DRIVE GEAR PUMP

4-Series Specifications

MODEL	41	43	44	45
Port Size	1/4" NPT/3/8" BSPT	1/4" NPT/3/8" BSPT	3/8" NPT/BSPT	3/8" NPT/BSPT
Max Flow @ 1750 RPM	0.5 GPM (1.9 LPM)	1.4 GPM (5.3 LPM)	2.4 GPM (9.1 LPM)	3.4 GPM (13 LPM)
Max Diff. Press.	100 PSI (7 BAR)	100 PSI (7 BAR)	100 PSI (7 BAR)	100 PSI (7 BAR)
Max Discharge Press.	300 PSI (21 BAR)	300 PSI (21 BAR)	300 PSI (21 BAR)	300 PSI (21 BAR)
Max Temperature	500°F (260°C)	500°F (260°C)	500°F (260°C)	500°F (260°C)
Min Temperature	-40°F (-40°C)	-40°F (-40°C)	-40°F (-40°C)	-40°F (-40°C)
Max Viscosity @ 300 RPM	4,500 CPS	3,700 CPS	2,000 CPS	1,000 CPS
NPSHR @ 1750 RPM	4.5 FT (1.4 M)	3 FT (0.9 M)	3 FT (0.9 M)	2 FT (0.6 M)
Lift (Dry)	0.5 FT (0.15 M)	1.5 FT (0.45 M)	2.0 FT (0.6 M)	4 FT (1.2 M)
Weight	11 LBS (5 KGS)	11 LBS (5 KGS)	13 LBS (6 KGS)	13 LBS (6 KGS)

4-SERIES PERFORMANCE CURVES

1 CPS Fluid (Water)

41-MC

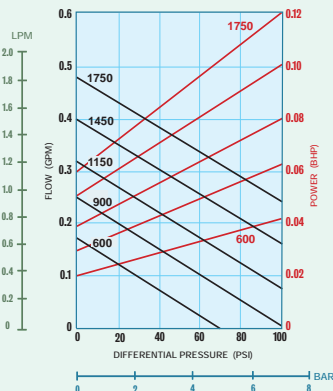

43-MC

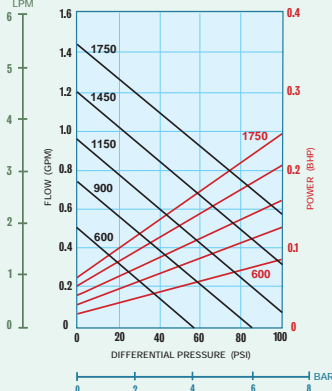

44-MC

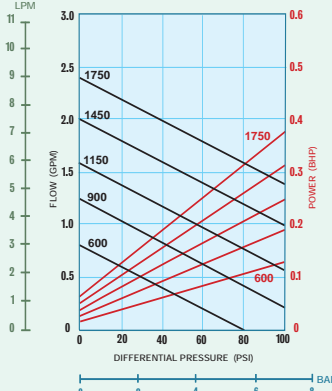

45-MC

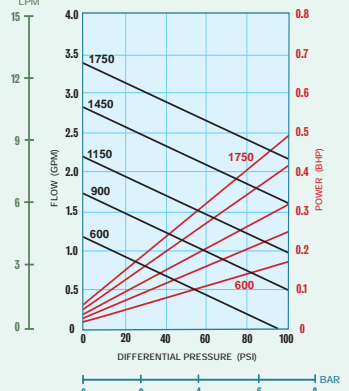

100 CPS Fluid (Oil)

41-MC

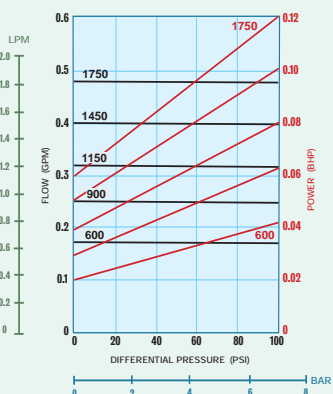

43-MC

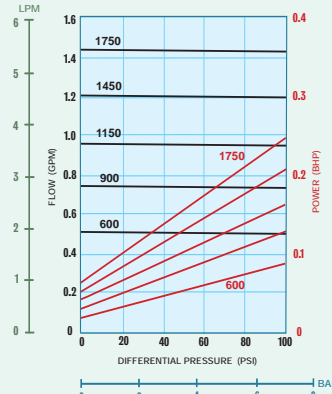

44-MC

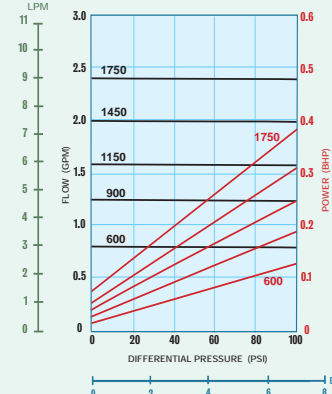

45-MC

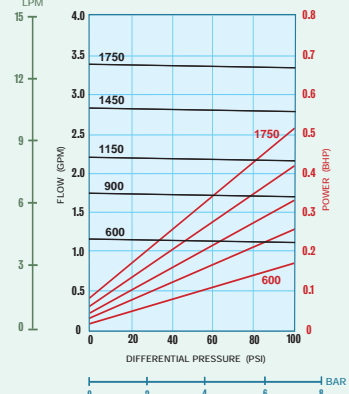

MAX™-SERIES HIGH-PRESSURE GEAR PUMP
 GENERAL INFORMATION

Close-coupled
 Mag-Drive: Models M0-M8
 Sealed: Models M5-M8



Close-coupled
 Sealed: Models M0-M4

High-Pressure Gear Pump

The **Liquiflo Max™ Series** Gear Pumps will handle differential pressures to **350 PSI** and flows to **20 GPM**. Its unique and durable design assures extended life even in high-pressure pumping applications where other gear pumps could fail. The **Max™ Series** pump features newly designed helical gears for smoother and quieter operation and intrinsic reduction of gear separation forces.

Mechanical Seal or Mag-Drive, Close-Coupled

These pumps are available in either **Single** or **Double Mechanical Seal** or **Mag-Drive** configurations. The universal seal housing will accommodate either a single or double mechanical seal. The **Max™ Series** pump close-couples to the motor to simplify installation and eliminate difficulties and inconveniences of aligning the pump and motor. The body material choice is either **316 SS** or **Titanium** with multiple choices of internal components to optimize your selection for specific chemical applications.

17-4 PH SS Integral Gear-Shaft Arrangement

Sealed Max-Series pumps are available with an **integral gear-shaft arrangement made of 17-4 PH SS** (precipitate hardened stainless steel). By using a heat-treated metal-to-metal gear configuration, higher pressures can be achieved without the risk of galling or accelerated wear. 17-4 PH SS materials are only recommended for moderately aggressive chemicals, and metal-to-metal gears should only be applied when pumping liquids with viscosities of at least 100 cP. Contact factory for specific applications.

Materials of Construction Available

BODY	GEARS	WEAR PLATES	BEARINGS	SHAFTS
316 SS	17-4 PH SS*	Carbon 60	Carbon 60	17-4 PH SS*
Titanium	316 SS	Silicon Carbide	Silicon Carbide	316 SS
	Titanium	PEEK	PEEK	TC-Coated
	PEEK	Teflon		CO-Coated
	Teflon			Titanium,
				TO-Coated

* Available as Integral Gear-Shaft for Sealed Pumps only.

Note: For information on the above materials, refer to the Engineering section, pages 132-135.

Repair Kits

Repair Kits simplify inventory and speed repair. All parts can also be purchased separately.



Max-Series Pump Characteristics

PUMP MODEL	MAX SPEED* (RPM)	DISPLACEMENT † RATE (Gal/Rev)	FLOW † @1800 RPM (GPM)	MAX DIFF. PRESSURE ‡ (PSI)	PORT SIZE (in)
Max-M0	3600	.00022	0.40	350	1/2
Max-M1	3600	.00055	1.0	350	1/2
Max-M2	3600	.00138	2.5	350	1/2
Max-M3	3600	.00193	3.5	350	1/2
Max-M4	3600	.00289	5.2	350	3/4
Max-M5	1800	.00491	8.8	350	3/4
Max-M6	1800	.00675	12.2	350	1
Max-M7	1800	.00859	15.5	350	1 ¹ / ₄
Max-M8	1800	.01105	20	350	1 ¹ / ₂

* Consult factory when operating over 1800 RPM.

† Based on zero slip.

‡ Maximum differential pressure is dependent upon fluid being pumped. Contact factory.

MAX-SERIES DESIGN FEATURES

Mag-Drive Models MO-M8

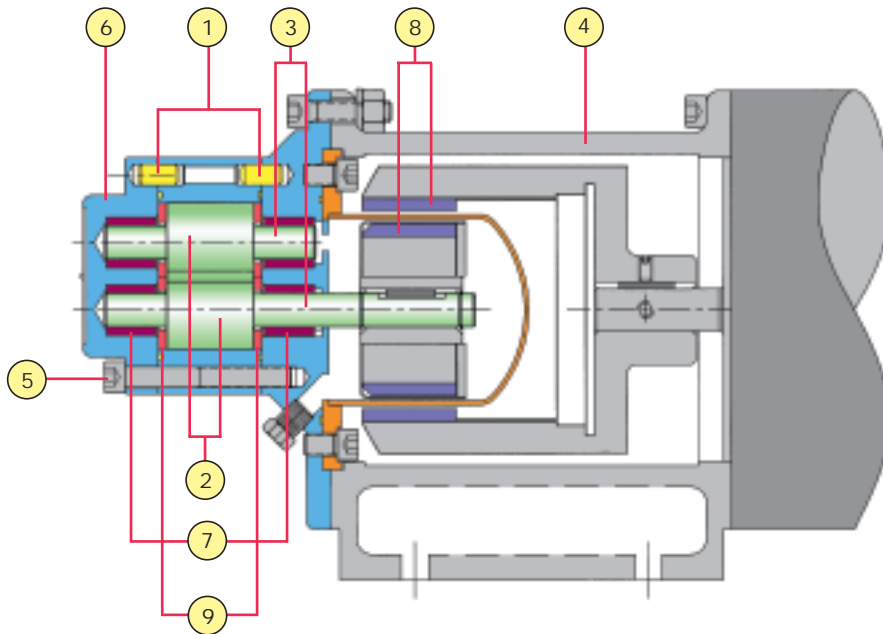

- 1 Hardened Stainless Steel Alignment Pins
- 2 Helical Gears for smoother and quieter operation
- 3 316 SS or Titanium Shafts (various coatings available)
- 4 Heavy Duty Cast Iron mounting bracket supports pump & motor
- 5 Heavy duty bolting and rugged construction
- 6 Solid 316 SS or Titanium Housings
- 7 Oversized Bearings for high-pressure applications
- 8 High-strength SmCo magnets
- 9 Relieved Wear Plates

Sealed Models MO-M4

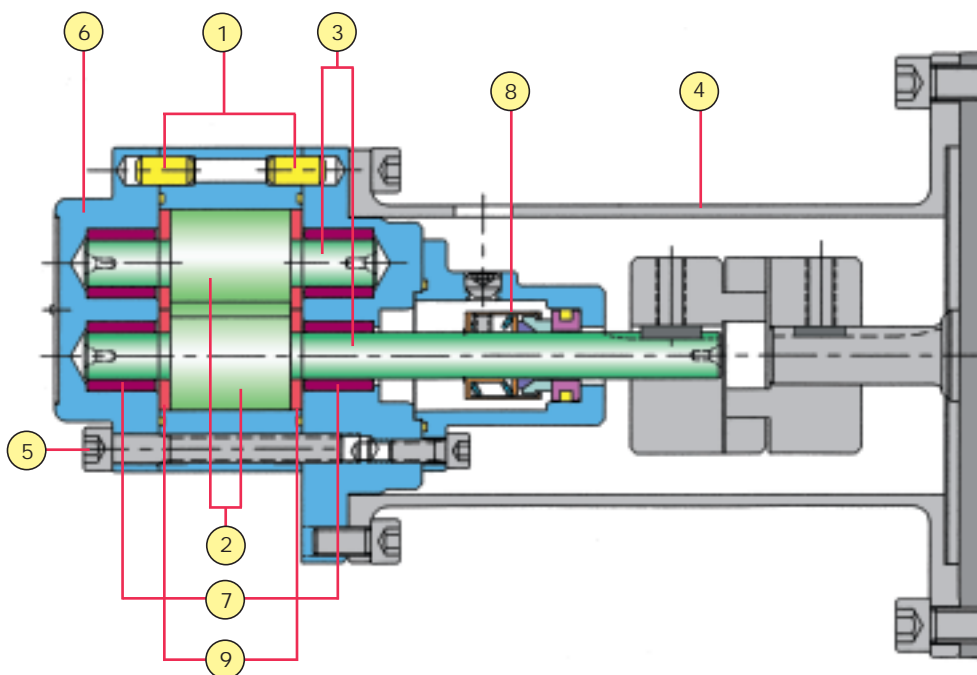

- 1 Hardened Stainless Steel Alignment Pins
- 2 Helical Gears for smoother and quieter operation – also available as Hardened Integral Gear-Shaft
- 3 316 SS shafts (coatings available) or 17-4 PH SS Integral Gear-Shaft
- 4 All Stainless Steel mounting bracket resists corrosion
- 5 Heavy duty bolting & rugged construction
- 6 316 Stainless Steel Housings
- 7 Oversized Bearings for high-pressure applications
- 8 Seal Chamber can accept Single or Double Mechanical Seal
- 9 Relieved Wear Plates

PUMP MODEL CODING

EXAMPLE:

M5S6PEEU0000, designates a Model M5 Pump with Single Mechanical Seal.

M5 S 6 P E E U 0 0 0 0 _
 1 2 3 4 5 6 7 8 9 10 11 12

Pos.	Description	Selection
1	Pump Model	M5 M5 Pump
2	Housing Mat'l	S 316 SS NPT
3	Drive Gear Mat'l	6 316 SS
4	Idler Gear Mat'l	P PEEK
5	Wear Plate Mat'l	E Carbon 60
6	Bearing Mat'l	E Carbon 60
7	Motor Frame Size	0 0.625" (56C)
8	Seal Type	U Single-Int, Carbon-SiC
9	Bearing Flush	0 None
10	Shafts	0 316 SS (uncoated)
11	O-Rings	0 Teflon
12	N/A	

Liquiflo's Model Code describes both the pump's size and materials selected. This model code is required for the future identification of your pump when reordering either a pump or replacement parts. Model code is permanently stamped into pump housing.

- Available
- ⊗ Not Available
- CF Contact Factory

Flanges available:
 ANSI, DIN, JIS,
 or slip joint flanges conforming to the dimensions
 of the standard.

CONNECTION SIZES

	M0 - M3	M4 / M5	M6	M7	M8
THREADED	1/2	3/4	1	1 1/4	1 1/2
FLANGED	1/2	3/4	1	1 1/4	1 1/2

Liquiflo Max®-Series Gear Pumps Selection & Availability



Sample Model No. **M5 S 6 P E E U 0 0 0 0**
 Position No. 1 2 3 4 5 6 7 8 9 10 11 12

Position Model	1 Pump Model	M0	M1	M2	M3	M4	M5	M6	M7	M8
Position Basic Material & Port Type	2 S = 316 SS NPT	■	■	■	■	■	■	■	■	■
	L = 316 SS Flanged	■	■	■	■	■	■	■	■	■
	X = 316 SS BSPT	■	■	■	■	■	■	■	■	■
	T = Titanium NPT	CF	CF	CF	CF	■	CF	■	CF	CF
	R = Titanium Flanged	CF	CF	CF	CF	■	CF	■	CF	CF
Z = Titanium BSPT	CF	CF	CF	CF	■	CF	■	CF	CF	
Position Drive Gear	3 4 = Titanium	CF	CF	CF	CF	■	CF	■	CF	■
	6 = 316 SS	■	■	■	■	■	■	■	■	■
	9 = 17-4 PH SS Integral Gear-Shaft†	■	■	■	■	■	■	■	■	■
	P = PEEK	■	■	■	■	■	■	■	■	■
Position Idler Gear	4 3 = Teflon	■	■	■	■	■	■	■	■	■
	6 = 316 SS	■	■	■	■	■	■	■	■	■
	9 = 17-4 PH SS Integral Gear-Shaft†	■	■	■	■	■	■	■	■	■
	P = PEEK	■	■	■	■	■	■	■	■	■
Position Wear Plates	5 3 = Teflon	■	■	■	■	■	■	■	■	■
	4 = Ceramic (SiC)	■	■	■	■	■	■	■	■	■
	E = Carbon 60	■	■	■	■	■	■	■	■	■
	P = PEEK	■	■	■	■	■	■	■	■	■
Position Bearings	6 B = Silicon Carbide	■	■	■	■	■	■	■	■	■
	E = Carbon 60	■	■	■	■	■	■	■	■	■
	P = PEEK	■	■	■	■	■	■	■	■	■
Position Motor Frame Size	7 0 = 0.625" (NEMA 56C/56HC)	■	■	■	■	■	■	■	■	■
	1 = 0.875" (NEMA 143/145TC)	■	■	■	■	■	■	■	■	■
	2 = 14 mm (IEC 71 - B5)	■	■	■	■	■	■	■	■	■
	3 = 19 mm (IEC 80 - B5)	■	■	■	■	■	■	■	■	■
	4 = 24 mm (IEC 90 - B5)	■	■	■	■	■	■	■	■	■
5 = 1.125" (NEMA 182/184TC)	⊗	⊗	⊗	⊗	⊗	■	■	■	■	
Position Seal Type* or Mag-Drive	8 U = Single-Int Carbon - SiC	■	■	■	■	■	■	■	■	■
	F = Double Carbon - SiC	■	■	■	■	■	■	■	■	■
	0 = Mag-Drive (Sealless)	■	■	■	■	■	■	■	■	■
Position Bearing Flush	9 0 = Standard Housings (without Bearing Flush)	■	■	■	■	■	■	■	■	■
	2 = Internal Bearing Flush	■	■	■	■	■	■	■	■	■
Position Shafts	10 0 = 316 SS (uncoated)	■	■	■	■	■	■	■	■	■
	1 = Ceramic Coated 316 SS	■	■	■	■	■	■	■	■	■
	2 = Tungsten Carbide Coated 316 SS	■	■	■	■	■	■	■	■	■
	3 = 17-4 PH SS Integral Gear-Shaft†	■	■	■	■	■	■	■	■	■
4 = TiO ₂ Coated Titanium	CF	CF	CF	CF	■	CF	■	CF	■	
Position O-Rings (Housing - Seal Seat†)	11 0 = Teflon - Viton	■	■	■	■	■	■	■	■	■
	V = Viton - Viton	■	■	■	■	■	■	■	■	■
	T = Teflon - Kalrez	■	■	■	■	■	■	■	■	■
	K = Kalrez - Kalrez	■	■	■	■	■	■	■	■	■
Position Magnetic Coupling (Mag-Drive Only)	12 U = (MCU) 75 in-lbs	■	■	■	■	■	⊗	⊗	⊗	⊗
	V = (MCB) 120 in-lbs	■	■	■	■	■	■	■	■	■
	B = (MCV) 200 in-lbs	■	■	■	■	■	■	■	■	■
Suffix Trim Options	- 8 = Temperature Trim	■	■	■	■	■	■	■	■	■
	- 9D = Viscosity Trim (double clearance)	■	■	■	■	■	■	■	■	■
	- 9T = Viscosity Trim (triple clearance)	■	■	■	■	■	■	■	■	■

† Available for Sealed Pumps only.

* Titanium Pumps are not available in Sealed configuration.

• Seal Seat O-ring is not applicable for Mag-Drive Pumps.

MO SEALED MO MAG-DRIVE



Sealed, Close-Coupled

Mag-Drive, Close-Coupled

PERFORMANCE CURVES

30 CPS Fluid (Oil)

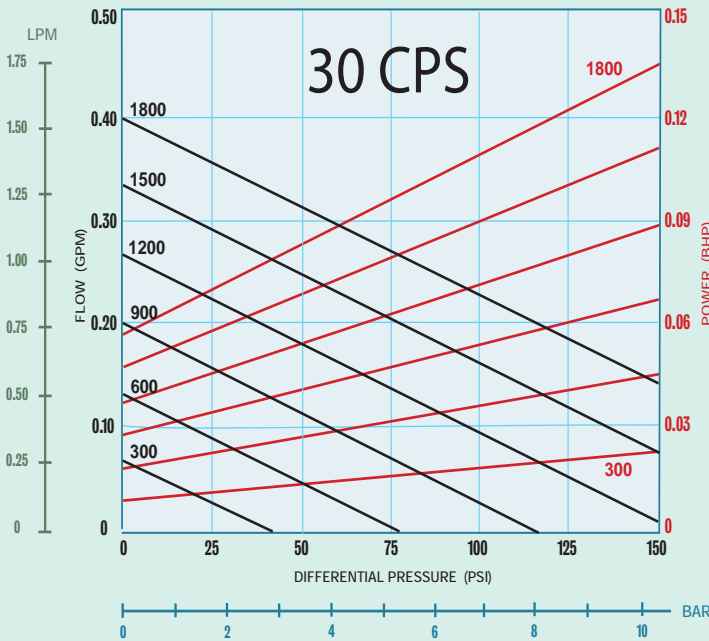

Note: Model MO is not recommended for viscosities below 30 cP.

100 CPS Fluid (Oil)

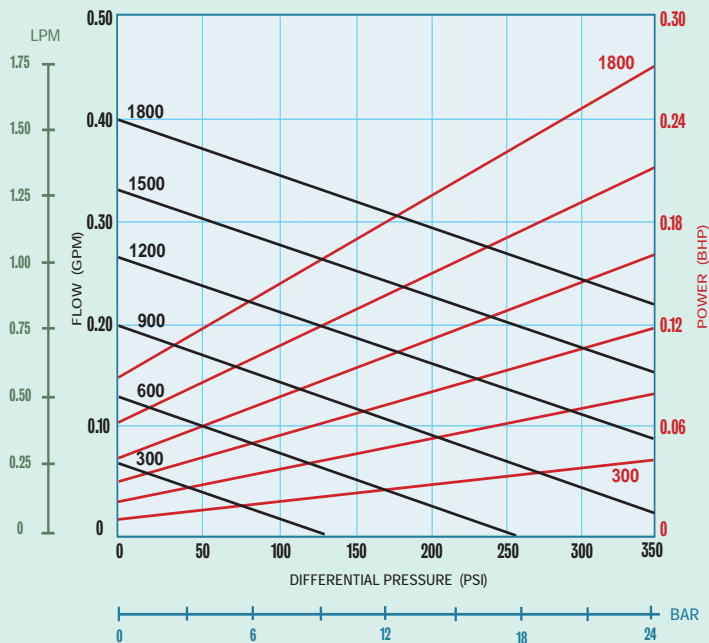

PORT SIZE	1/2" NPT/BSPT/FLG
MAX FLOW	0.40 GPM; 1.5 LPM
MAX DIFFERENTIAL PRESSURE	350 PSI; 24.1 BAR
MAX DISCHARGE PRESSURE	500 PSI; 34.5 BAR †
MAX TEMPERATURE	500°F; 260°C
MIN TEMPERATURE	-40°F; -40°C
MAX VISCOSITY	100,000* CPS
NPSHR @ 1750 RPM	3 FT; 0.9 M
LIFT (DRY)	0.5 FT; 0.15 M
WEIGHT (without motor) SEALED, Close-Coupled MAG-DRIVE, Close-Coupled	32 LBS; 14.5 KGS 38 LBS; 17.3 KGS

* Higher viscosities possible. Contact factory.

† Derating required for flanged pumps based on flange type and application temperature.

Dimensional Data
(inches)

MO Sealed, Close-Coupled

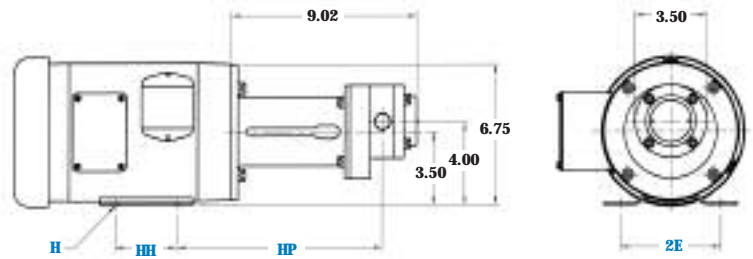

MOTOR FRAME	DIMENSIONAL DATA (inches)			
	H (Hole)	HH	HP	2E
NEMA 56C	0.34 Slot	3.00	9.89	4.88
NEMA 143TC	0.34 Thru	4.00	9.70	5.50
NEMA 145TC	0.34 Thru	5.00	9.70	5.50

Dimensional Data
(inches)

MO Mag-Drive, Close-Coupled

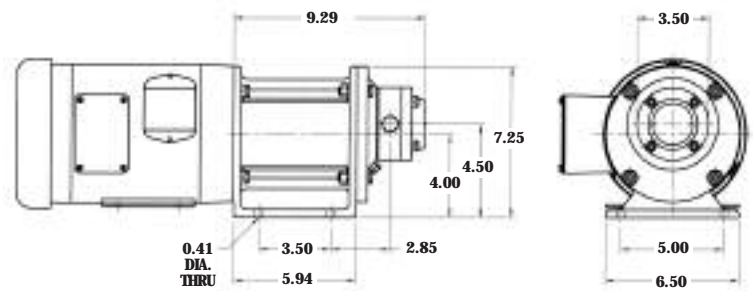

M1 SEALED M1 MAG-DRIVE



MAX-SERIES
GEAR PUMP



Sealed, Close-Coupled

Mag-Drive, Close-Coupled

PORT SIZE	1/2" NPT/BSPT/FLG
MAX FLOW	1.0 GPM; 3.8 LPM
MAX DIFFERENTIAL PRESSURE	350 PSI; 24.1 BAR
MAX DISCHARGE PRESSURE	500 PSI; 34.5 BAR †
MAX TEMPERATURE	500°F; 260°C
MIN TEMPERATURE	-40°F; -40°C
MAX VISCOSITY	100,000* CPS
NPSHR @ 1750 RPM	3 FT; 0.9 M
LIFT (DRY)	1 FT; 0.3 M
WEIGHT (without motor)	
SEALED, Close-Coupled	32.5 LBS; 14.8 KGS
MAG-DRIVE, Close-Coupled	38.5 LBS; 17.5 KGS

* Higher viscosities possible. Contact factory.

† Derating required for flanged pumps based on flange type and application temperature.

PERFORMANCE CURVES

30 CPS Fluid (Oil)

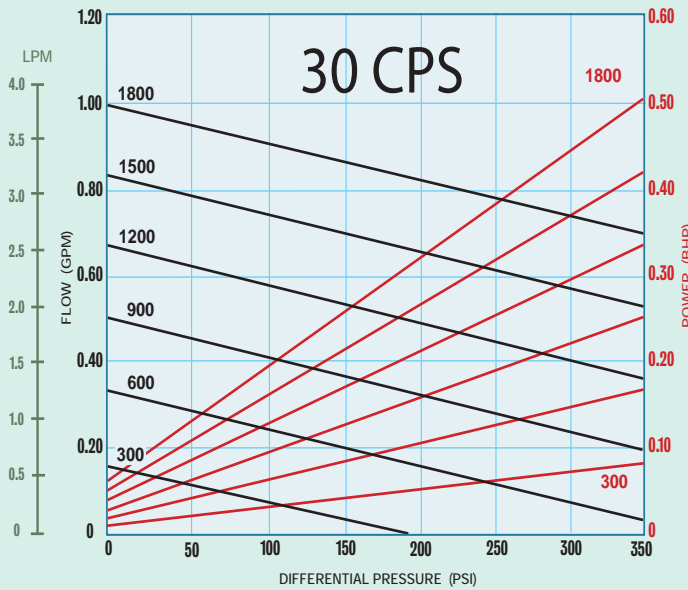

Note: Model M1 is not recommended for viscosities below 10 cP. For viscosities of 10-20 cP, limit differential pressure to 150 PSI.

100 CPS Fluid (Oil)

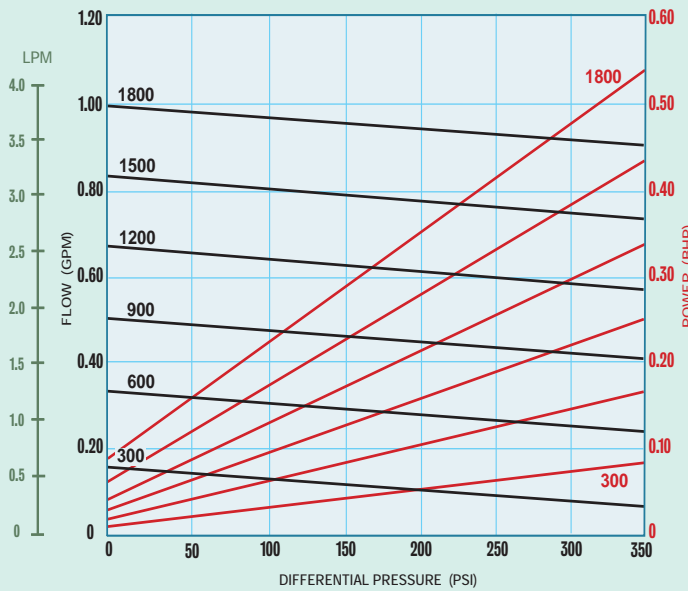

Dimensional Data (inches)

M1 Sealed, Close-Coupled

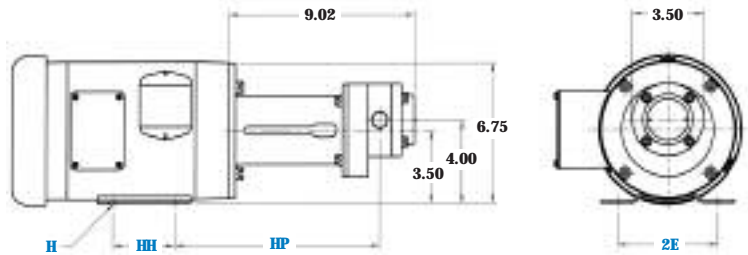

MOTOR FRAME	DIMENSIONAL DATA (inches)			
	H (Hole)	HH	HP	2E
NEMA 56C	0.34 Slot	3.00	9.89	4.88
NEMA 143TC	0.34 Thru	4.00	9.70	5.50
NEMA 145TC	0.34 Thru	5.00	9.70	5.50

Dimensional Data (inches)

M1 Mag-Drive, Close-Coupled

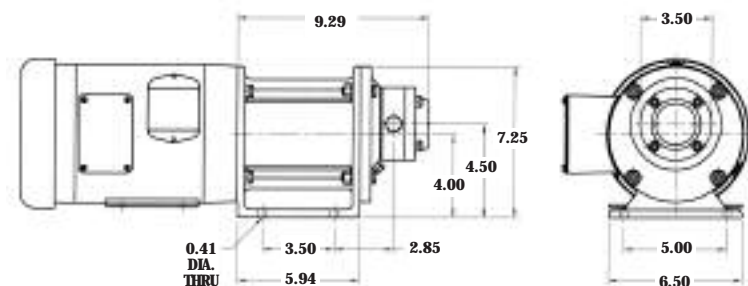

M2 SEALED M2 MAG-DRIVE



Sealed, Close-Coupled

Mag-Drive, Close-Coupled

PORT SIZE	1/2" NPT/BSPT/FLG
MAX FLOW	2.5 GPM; 9.4 LPM
MAX DIFFERENTIAL PRESSURE	350 PSI; 24.1 BAR
MAX DISCHARGE PRESSURE	500 PSI; 34.5 BAR †
MAX TEMPERATURE	500°F; 260°C
MIN TEMPERATURE	-40°F; -40°C
MAX VISCOSITY	100,000* CPS
NPSHR @ 1750 RPM	2 FT; 0.6 M
LIFT (DRY)	2 FT; 0.6 M
WEIGHT (without motor)	
SEALED, Close-Coupled	33 LBS; 15.0 KGS
MAG-DRIVE, Close-Coupled	39 LBS; 17.7 KGS

* Higher viscosities possible. Contact factory.

† Derating required for flanged pumps based on flange type and application temperature.

PERFORMANCE CURVES

1 CPS Fluid (Water)

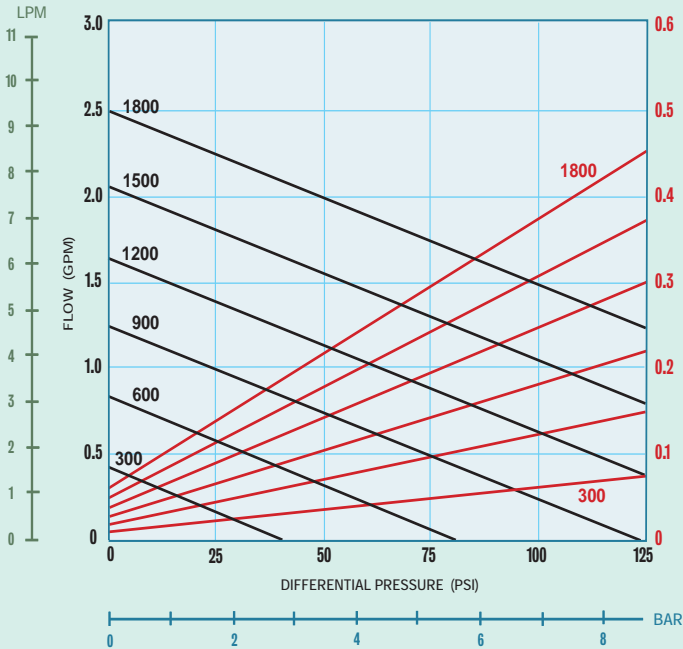

0 2 4 6 8 BAR

0 25 50 75 100 125 PSI

0 0.1 0.2 0.3 0.4 0.5 0.6 BHP

0 1 2 3 4 5 6 7 8 9 10 11 LPM

0 0.5 1.0 1.5 2.0 2.5 3.0 GPM

0 300 600 900 1200 1500 1800

0 25 50 75 100 125 PSI

0 0.1 0.2 0.3 0.4 0.5 0.6 BHP

0 2 4 6 8 BAR

0 0.1 0.2 0.3 0.4 0.5 0.6 BHP

0 300 600 900 1200 1500 1800

0 25 50 75 100 125 PSI

0 0.1 0.2 0.3 0.4 0.5 0.6 BHP

0 2 4 6 8 BAR

0 0.1 0.2 0.3 0.4 0.5 0.6 BHP

0 300 600 900 1200 1500 1800

0 25 50 75 100 125 PSI

0 0.1 0.2 0.3 0.4 0.5 0.6 BHP

0 2 4 6 8 BAR

0 0.1 0.2 0.3 0.4 0.5 0.6 BHP

0 300 600 900 1200 1500 1800

0 25 50 75 100 125 PSI

0 0.1 0.2 0.3 0.4 0.5 0.6 BHP

0 2 4 6 8 BAR

0 0.1 0.2 0.3 0.4 0.5 0.6 BHP

0 300 600 900 1200 1500 1800

0 25 50 75 100 125 PSI

0 0.1 0.2 0.3 0.4 0.5 0.6 BHP

0 2 4 6 8 BAR

0 0.1 0.2 0.3 0.4 0.5 0.6 BHP

0 300 600 900 1200 1500 1800

0 25 50 75 100 125 PSI

0 0.1 0.2 0.3 0.4 0.5 0.6 BHP

0 2 4 6 8 BAR

0 0.1 0.2 0.3 0.4 0.5 0.6 BHP

0 300 600 900 1200 1500 1800

0 25 50 75 100 125 PSI

0 0.1 0.2 0.3 0.4 0.5 0.6 BHP

0 2 4 6 8 BAR

0 0.1 0.2 0.3 0.4 0.5 0.6 BHP

M2 Sealed, Close-Coupled

Dimensional Data

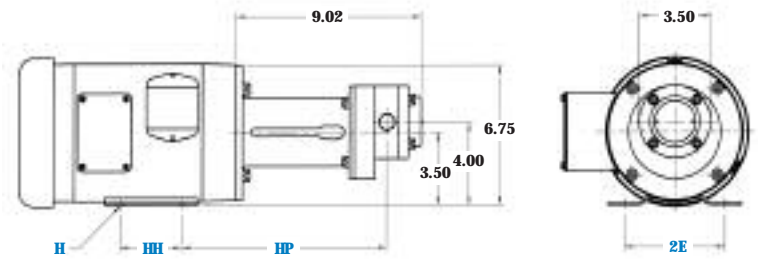

DIMENSIONAL DATA (inches)

MOTOR FRAME	H (Hole)	HH	HP	2E
NEMA 56C	0.34 Slot	3.00	9.89	4.88
NEMA 143TC	0.34 Thru	4.00	9.70	5.50
NEMA 145TC	0.34 Thru	5.00	9.70	5.50

M2 Mag-Drive, Close-Coupled

Dimensional Data (inches)

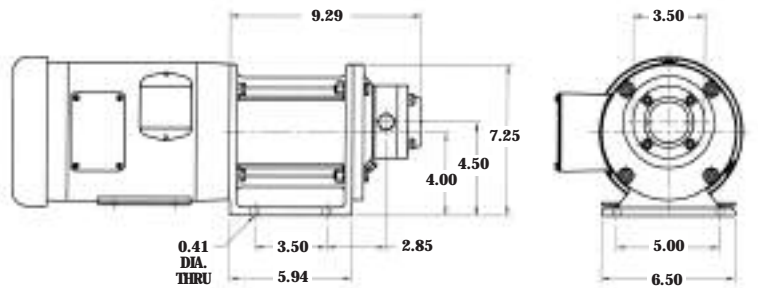

M3 SEALED M3 MAG-DRIVE



MAX-SERIES
GEAR PUMP



Sealed, Close-Coupled

Mag-Drive, Close-Coupled

PORT SIZE	1/2" NPT/BSPT/FLG
MAX FLOW	3.5 GPM; 13.1 LPM
MAX DIFFERENTIAL PRESSURE	350 PSI; 24.1 BAR
MAX DISCHARGE PRESSURE	500 PSI; 34.5 BAR †
MAX TEMPERATURE	500°F; 260°C
MIN TEMPERATURE	-40°F; -40°C
MAX VISCOSITY	100,000* CPS
NPSHR @ 1750 RPM	2 FT; 0.6 M
LIFT (DRY)	4 FT; 1.2 M
WEIGHT (without motor) SEALED, Close-Coupled MAG-DRIVE, Close-Coupled	33.5 LBS; 15.2 KGS 39.5 LBS; 17.9 KGS

* Higher viscosities possible. Contact factory.

† Derating required for flanged pumps based on flange type and application temperature.

PERFORMANCE CURVES

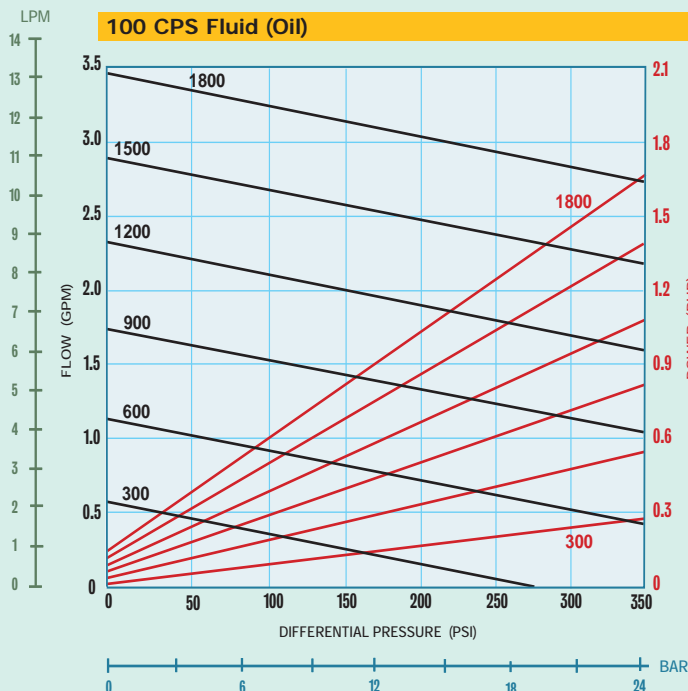
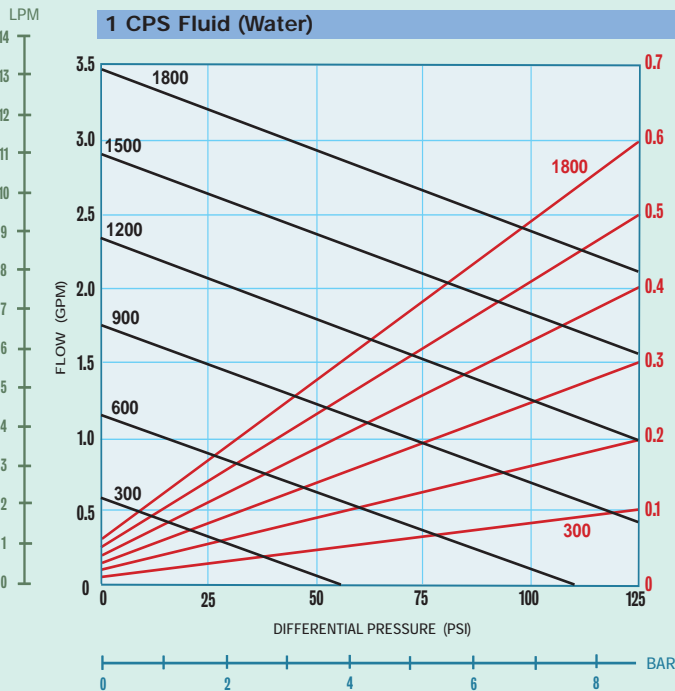

Dimensional Data (inches)

M3 Sealed, Close-Coupled

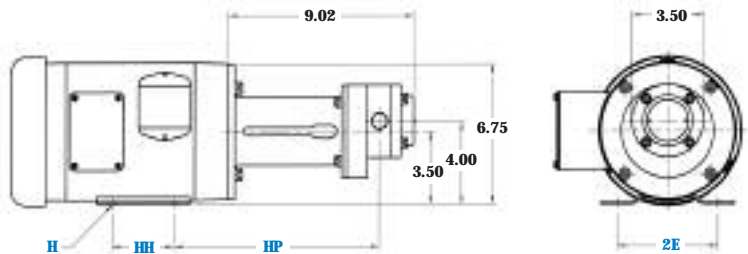

	DIMENSIONAL DATA (inches)			
MOTOR FRAME	H (Hole)	HH	HP	2E
NEMA 56C	0.34 Slot	3.00	9.89	4.88
NEMA 143TC	0.34 Thru	4.00	9.70	5.50
NEMA 145TC	0.34 Thru	5.00	9.70	5.50

Dimensional Data (inches)

M3 Mag-Drive, Close-Coupled

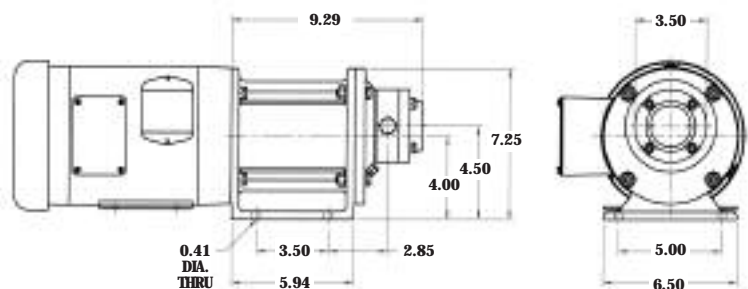

M4 SEALED M4 MAG-DRIVE



Sealed, Close-Coupled

Mag-Drive, Close-Coupled

PERFORMANCE CURVES

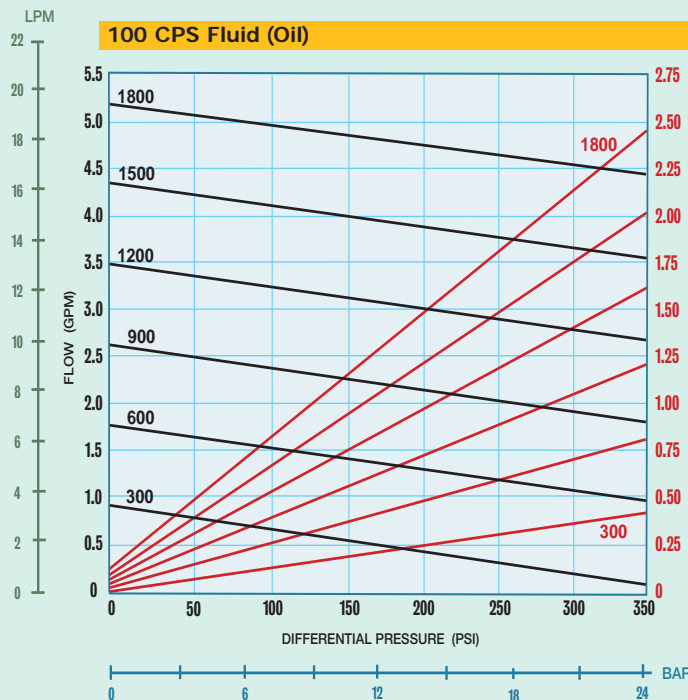
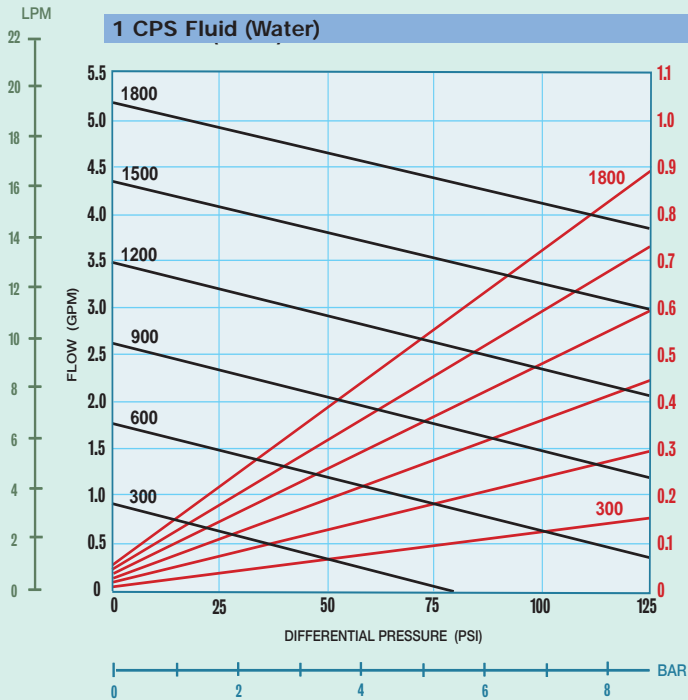

PORT SIZE	3/4" NPT/BSPT/FLG
MAX FLOW	5.2 GPM; 19.7 LPM
MAX DIFFERENTIAL PRESSURE	350 PSI; 24.1 BAR
MAX DISCHARGE PRESSURE	500 PSI; 34.5 BAR †
MAX TEMPERATURE	500°F; 260°C
MIN TEMPERATURE	-40°F; -40°C
MAX VISCOSITY	100,000* CPS
NPSHR @ 1750 RPM	5 FT; 1.5 M
LIFT (DRY)	6 FT; 1.8 M
WEIGHT (without motor)	
SEALED, Close-Coupled	34 LBS; 15.5 KGS
MAG-DRIVE, Close-Coupled	40 LBS; 18.2 KGS

* Higher viscosities possible. Contact factory.

† Derating required for flanged pumps based on flange type and application temperature.

Dimensional Data (inches)

M4 Sealed, Close-Coupled

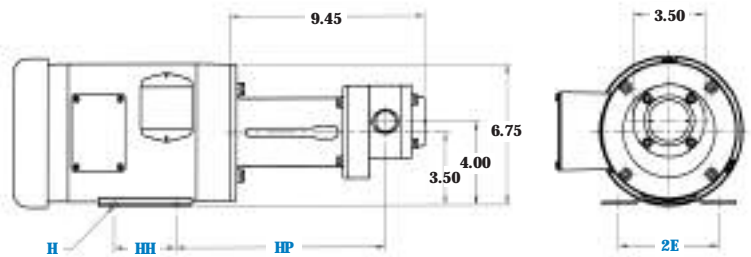

MOTOR FRAME	DIMENSIONAL DATA (inches)			
	H (Hole)	HH	HP	2E
NEMA 56C	0.34 Slot	3.00	10.10	4.88
NEMA 143TC	0.34 Thru	4.00	9.91	5.50
NEMA 145TC	0.34 Thru	5.00	9.91	5.50

Dimensional Data (inches)

M4 Mag-Drive, Close-Coupled

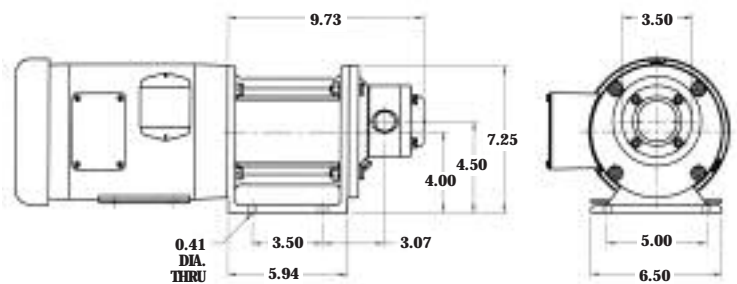

M5 SEALED M5 MAG-DRIVE

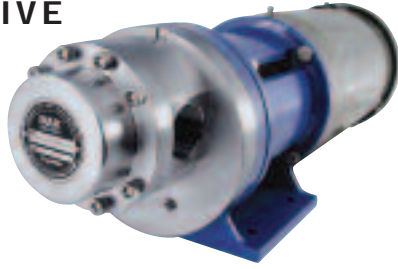

Sealed or Mag-Drive, Close-Coupled



MAX-SERIES
GEAR PUMP

PORT SIZE	3/4" NPT/BSPT/FLG
MAX FLOW	8.8 GPM; 33.5 LPM
MAX DIFFERENTIAL PRESSURE	350 PSI; 24.1 BAR
MAX DISCHARGE PRESSURE	500 PSI; 34.5 BAR †
MAX TEMPERATURE	500°F; 260°C
MIN TEMPERATURE	-40°F; -40°C
MAX VISCOSITY	100,000* CPS
NPSHR @ 1750 RPM	5 FT; 1.5 M
LIFT (DRY)	6 FT; 1.8 M
WEIGHT (without motor)	
SEALED, Close-Coupled	42 LBS; 19.1 KGS
MAG-DRIVE, Close-Coupled	42 LBS; 19.1 KGS

* Higher viscosities possible. Contact factory.

† Derating required for flanged pumps based on flange type and application temperature.

PERFORMANCE CURVES

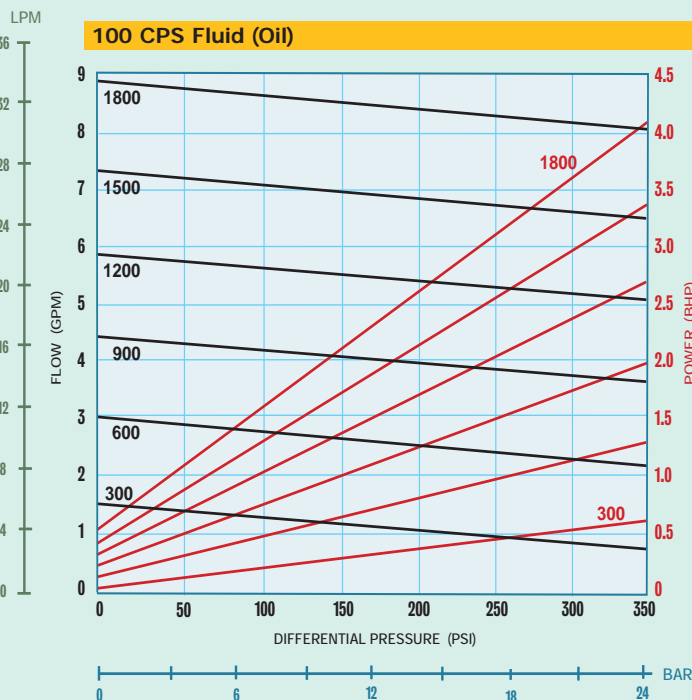
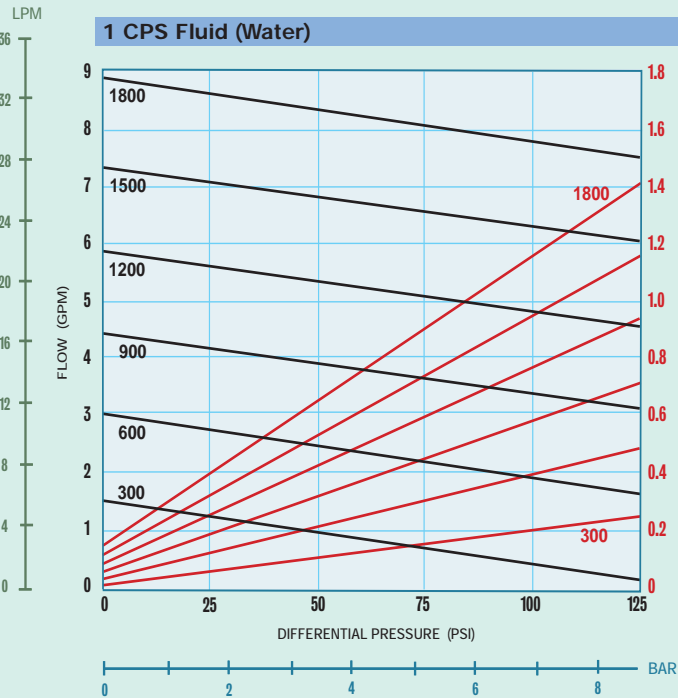

Dimensional Data
(inches)

M5 Sealed, Close-Coupled

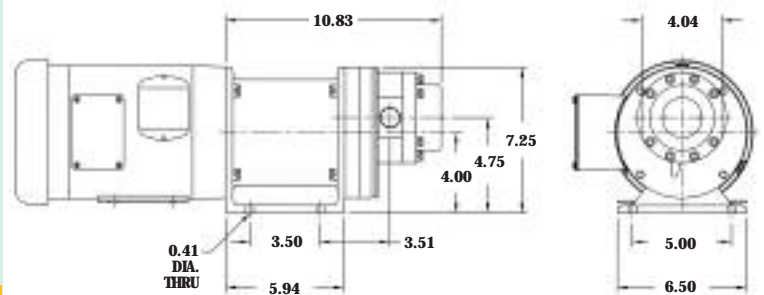

Dimensional Data
(inches)

M5 Mag-Drive, Close-Coupled

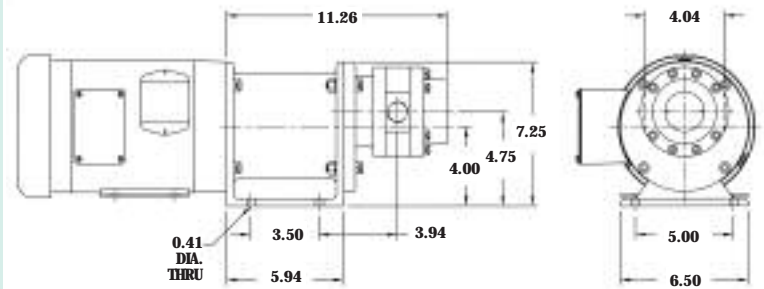

M6 SEALED M6 MAG-DRIVE



Sealed or Mag-Drive, Close-Coupled



MAX-SERIES
GEAR PUMP

PORT SIZE	1" NPT/BSPT/FLG
MAX FLOW	12.2 GPM; 46 LPM
MAX DIFFERENTIAL PRESSURE	350 PSI; 24.1 BAR
MAX DISCHARGE PRESSURE	500 PSI; 34.5 BAR †
MAX TEMPERATURE	500°F; 260°C
MIN TEMPERATURE	-40°F; -40°C
MAX VISCOSITY	100,000* CPS
NPSHR @ 1750 RPM	5 FT; 1.5 M
LIFT (DRY)	7 FT; 2.1 M
WEIGHT (without motor)	
SEALED, Close-Coupled	54 LBS; 24.5 KGS
MAG-DRIVE, Close-Coupled	54 LBS; 24.5 KGS

* Higher viscosities possible. Contact factory.

† Derating required for flanged pumps based on flange type and application temperature.

PERFORMANCE CURVES

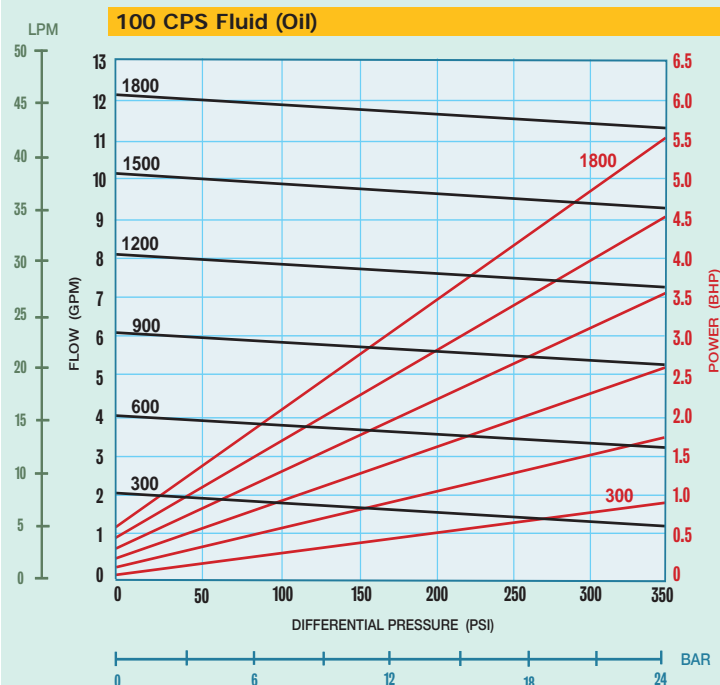
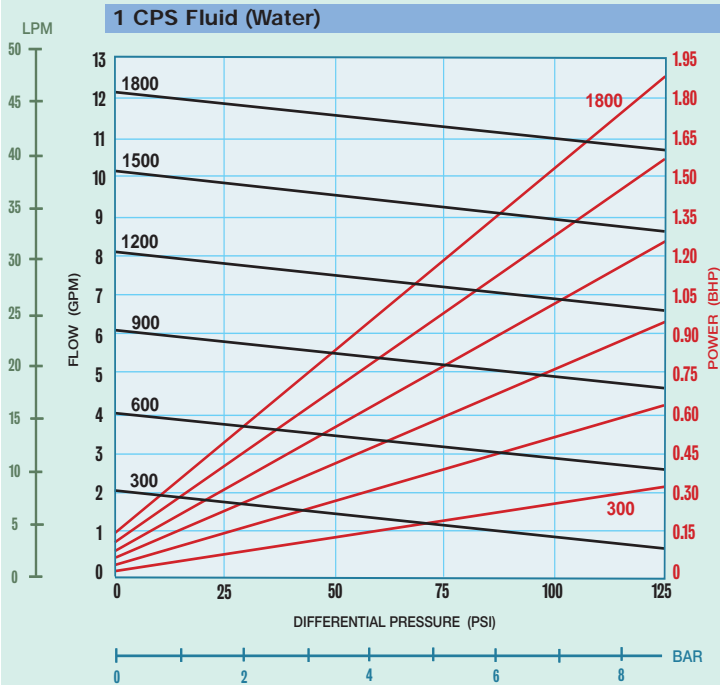

Dimensional Data
(inches)

M6 Sealed, Close-Coupled

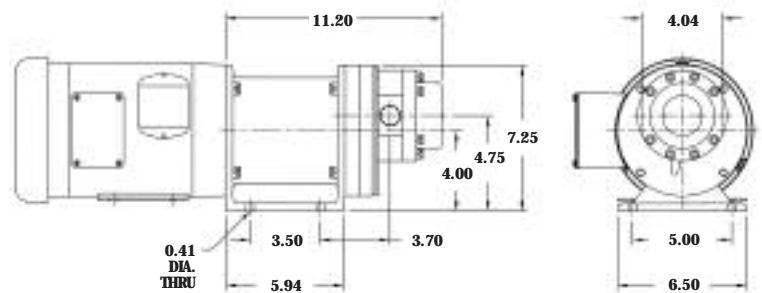

Dimensional Data
(inches)

M6 Mag-Drive, Close-Coupled

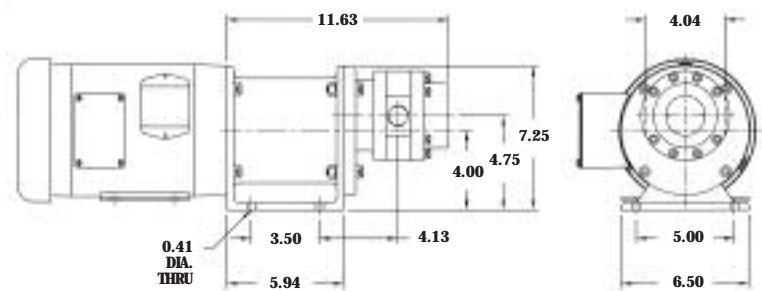

M7 SEALED M7 MAG-DRIVE



Sealed or Mag-Drive, Close-Coupled



MAX-SERIES
GEAR PUMP

PORT SIZE	1 1/4" NPT/BSPT/FLG
MAX FLOW	15.5 GPM; 58.5 LPM
MAX DIFFERENTIAL PRESSURE	350 PSI; 24.1 BAR
MAX DISCHARGE PRESSURE	500 PSI; 34.5 BAR †
MAX TEMPERATURE	500°F; 260°C
MIN TEMPERATURE	-40°F; -40°C
MAX VISCOSITY	100,000* CPS
NPSHR @ 1750 RPM	4 FT; 1.2 M
LIFT (DRY)	6 FT; 1.8 M
WEIGHT (without motor) SEALED, Close-Coupled MAG-DRIVE, Close-Coupled	55.5 LBS; 25.2 KGS 55.5 LBS; 25.2 KGS

* Higher viscosities possible. Contact factory.

† Derating required for flanged pumps based on flange type and application temperature.

PERFORMANCE CURVES

1 CPS Fluid (Water)

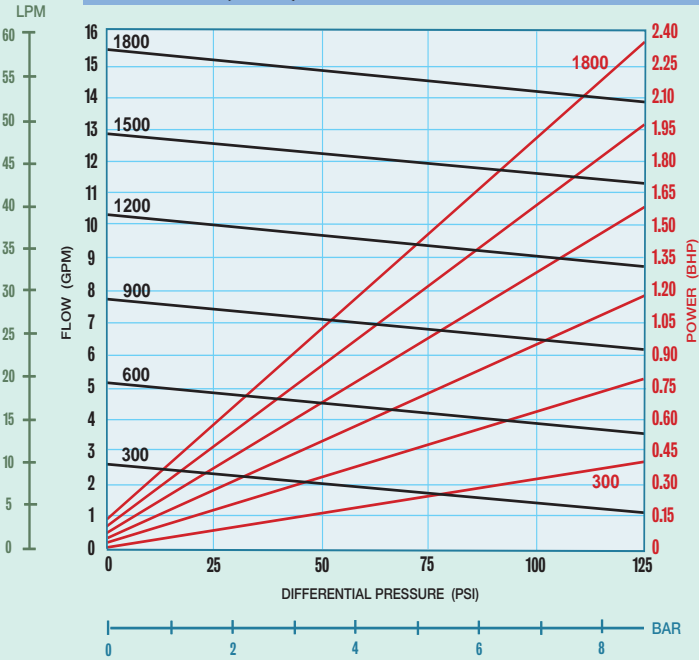

100 CPS Fluid (Oil)

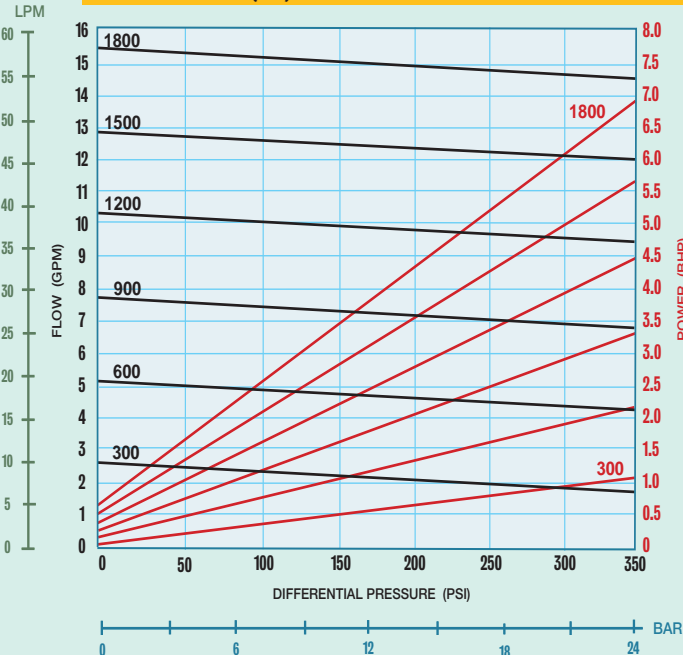

Dimensional Data (inches)

M7 Sealed, Close-Coupled

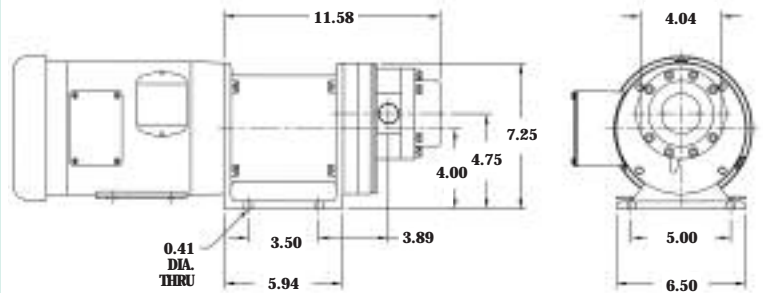

Dimensional Data (inches)

M7 Mag-Drive, Close-Coupled

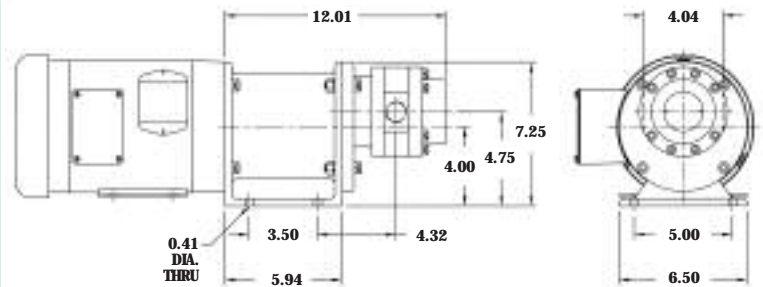

M8 SEALED M8 MAG-DRIVE



Sealed or Mag-Drive, Close-Coupled

PORT SIZE	1 1/2" NPT/BSPT/FLG
MAX FLOW	20 GPM; 75 LPM
MAX DIFFERENTIAL PRESSURE	350 PSI; 24.1 BAR
MAX DISCHARGE PRESSURE	500 PSI; 34.5 BAR †
MAX TEMPERATURE	500°F; 260°C
MIN TEMPERATURE	-40°F; -40°C
MAX VISCOSITY	100,000* CPS
NPSHR @ 1750 RPM	3 FT; 0.9 M
LIFT (DRY)	14 FT; 4.3 M
WEIGHT (without motor)	
SEALED, Close-Coupled	56 LBS; 25.4 KGS
MAG-DRIVE, Close-Coupled	56 LBS; 25.4 KGS

* Higher viscosities possible. Contact factory.

† Derating required for flanged pumps based on flange type and application temperature.

PERFORMANCE CURVES

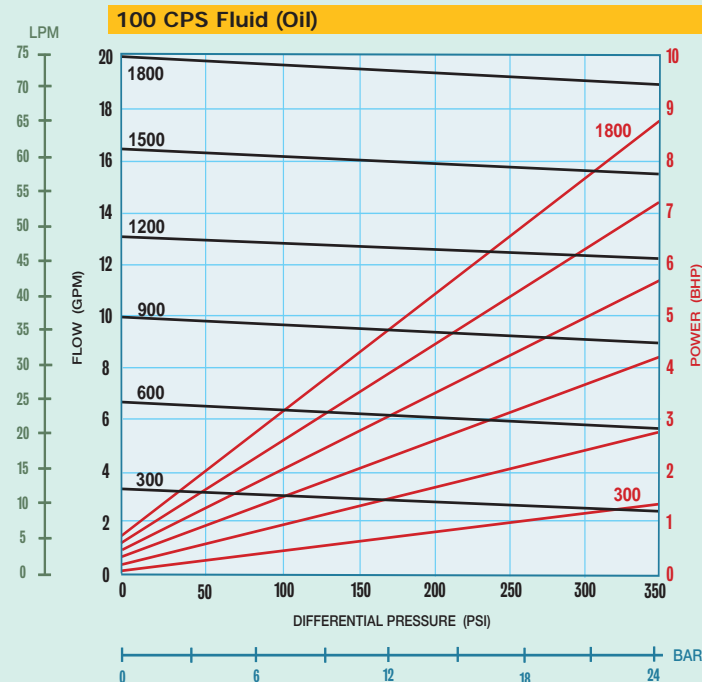
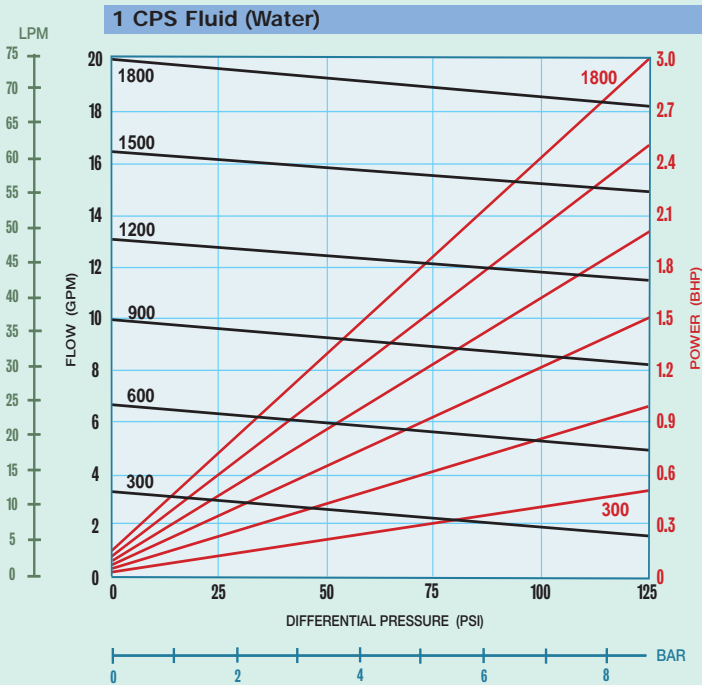

Dimensional Data
(inches)

M8 Sealed, Close-Coupled

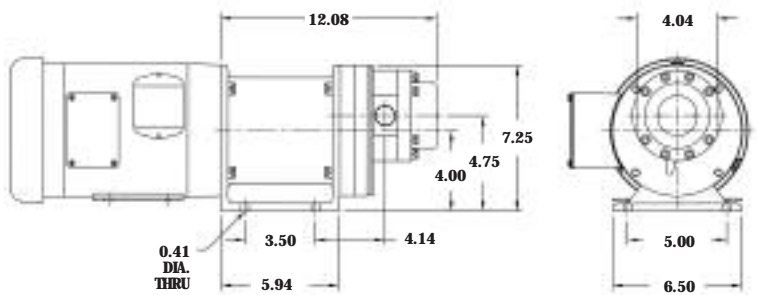

Dimensional Data
(inches)

M8 Mag-Drive, Close-Coupled

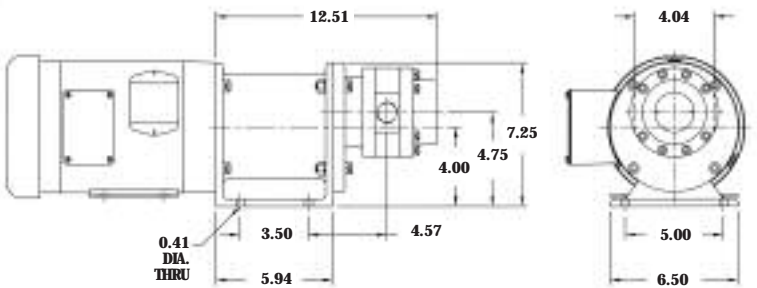

CENTRY® SUB-ANSI CENTRIFUGAL PUMPS

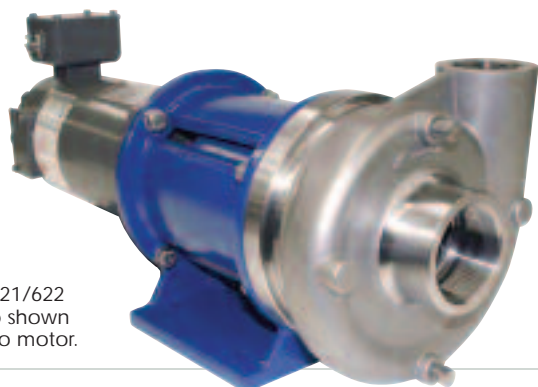

Centry® Model 621/622
Mag-Drive Pump shown
Close-Coupled to motor.



Centry® Model 621/622 Sealed Pump
shown Close-Coupled to motor.

The **Centry® Series** are Sealed and Magnetically-Coupled (MC) Centrifugal pumps engineered and manufactured for the user with increased needs for equipment reliability. These pumps are specifically designed to handle the lower flow applications that create maintenance problems for standard ANSI pumps operating at less than BEP. The Centry Series pumps can handle flows up to 160 GPM and heads up to 100 ft. They are available in 316 Stainless Steel or Alloy-C constructions, and with threaded or flanged port configurations.

Liquiflo's Centry® line of Centrifugal pumps are available in 316 SS or Alloy-C with either Packing, Single Mechanical Seal, Double Mechanical Seal or Mag-Drive configuration.

MODELS AVAILABLE

MODEL	SIZE* (inches)	MAX FLOW	MAX HEAD
620	1 x 3/4 x 3 3/4	45 GPM	65 ft
621	1 1/4 x 1 x 5	90 GPM	100 ft
622	2 x 1 1/2 x 5	160 GPM	95 ft

* Suction Port Size x Discharge Port Size x Impeller Diameter

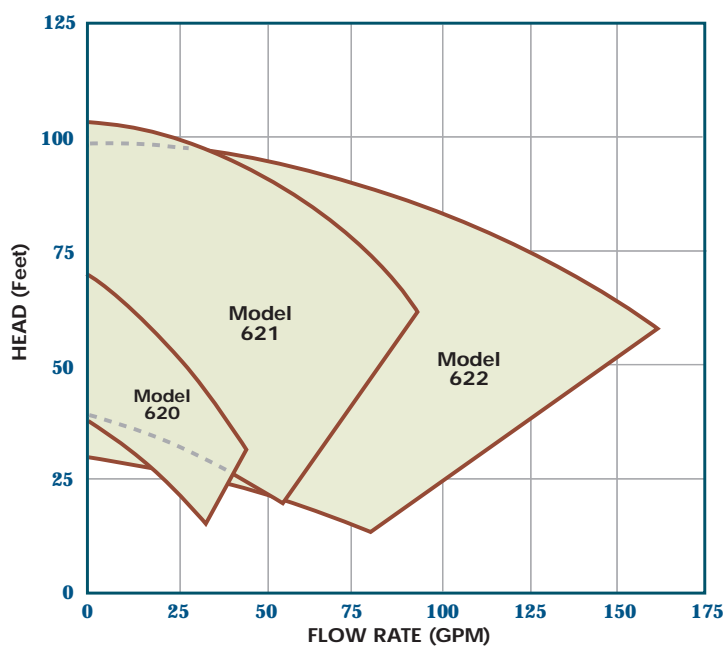

FEATURES

Centry® Models 621 and 622 are available with closed impellers as standard. Closed impellers eliminate axial loads and extend the life of the motor bearings when the pump is close-coupled to the motor. For close-coupled sealed pumps, closed impellers simplify the axial positioning of the impeller.

Single Mechanical Seals:

Single mechanical seals are the most economical type of seal to use when leakage is not desired. When properly installed and maintained, these seals will generally give years of trouble-free service.

Double Mechanical Seals:

Double Mechanical seals are also available for the Liquiflo Centry® Series centrifugal pumps. This seal configuration relies on a barrier lubrication system to cool and lubricate the seal faces.

Magnetically-Coupled Pumps:

These offer a simple and cost-effective solution to sealing toxic, noxious, crystallizing or most other fluids that present problems for single seals and would therefore require use of a double mechanical seal. Magnetically-coupled pumps eliminate the need for cooling loops that are required for double mechanical seals.

CUSTOMIZATION

Contact factory.

Features of Sealed and Sealless Centry® Pumps



Centry® Model 620 Sealed Pump shown Close-Coupled to motor.

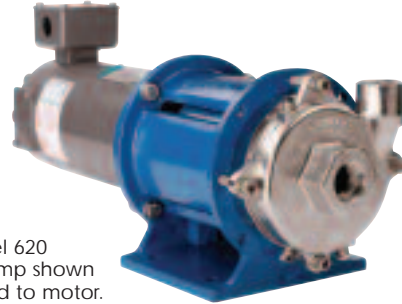

Centry® Model 620 Mag-Drive Pump shown Close-Coupled to motor.

Mechanically Sealed Pumps:

- Compact close-coupled design or long-coupled mounting
- Back pullout design to simplify maintenance
- Type 9 or Type 21 seals are available
- Several choices for seal materials to meet the requirements of the application
- Single or Double mechanical seal configurations are available

SEALED PUMP

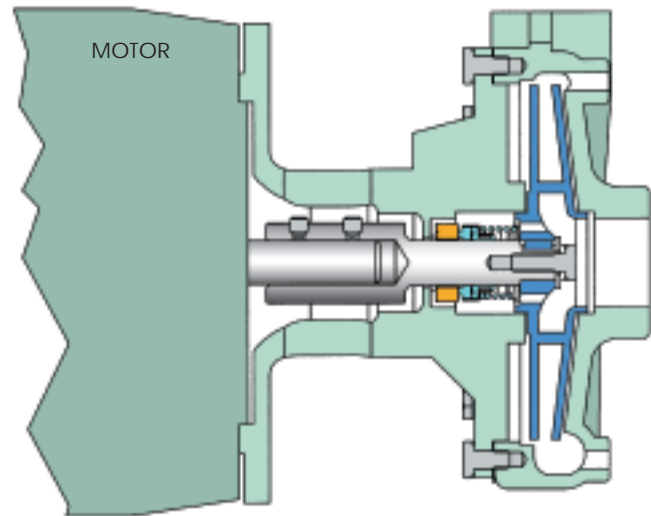

Centry® Model 621 or Model 622

Mag-Drive Pumps:

- Double support sleeve bearings are available in Carbon or Silicon Carbide to extend the working life of the pump
- Optional hard Ceramic coated or Tungsten Carbide coated shafts are available for abrasive or thin fluids
- Available in compact close-coupled or Power Frame design, depending on model

MAG-DRIVE PUMP

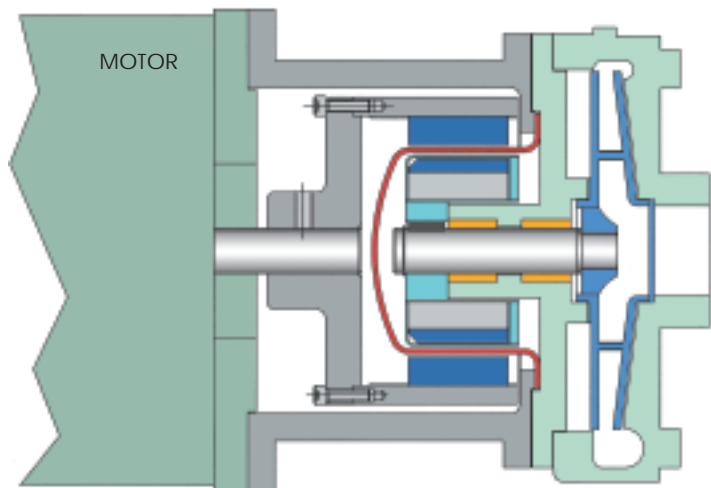

Centry® Model 621 or Model 622

PUMP MODEL CODING



CENTRY-SERIES
CENTRIFUGAL PUMPS

EXAMPLE:

620FS2000, designates a Centry Model 620 Sealed Centrifugal Pump.

620	F	S	2	0	0	0
1	2	3	4	5	6	7

Pos.	Description	Selection
1	Pump Model	620 Model 620
2	Impeller Diameter	F Full- 3.75"
3	Basic Material	S 316 SS
4	Seal Configuration	2 Sing. Int. Mech.
5	Motor Frame	0 NEMA 56C
6	O-Rings/Gaskets	0 Teflon
7	Impeller Trim	0 No Trim

EXAMPLE:

622RSEB12VF2, designates a Centry Model 622 Mag-drive Centrifugal Pump.

622	R	S	E	B	1	2	V	F	2
1	2	3	4	5	6	7	8	9	10

Pos.	Description	Code Selection
1	Pump Model	622 Model 622
2	Impeller Diameter	R Reduced
3	Basic Material	S 316 SS
4	Bearings	E Carbon 60
5	Thrust Washers	B SiC
6	Motor Frame	1 143TC/145TC
7	Shaft Coating	2 TC-coated
8	O-Rings/Gaskets	V Viton
9	Magnetic Coupling	E MCF, 120 in-lbs
10	Impeller Trim	2 4.0" Dia.

Liquiflo's Model Code describes both the pump's size and materials selected. This model code is required for the future identification of your pump when reordering either a pump or replacement parts. Model code is permanently stamped into pump housing.

- Available
- ⊗ Not Available
- CF Contact Factory

SEALED Pump Sample Model No. **620 F S 2 0 0 0**

Position No. 1 2 3 4 5 6 7

Position Model	1	SEALED Pump Model	620	621	622
Position Impeller Diameter	2	F = Full - 3.75" / 5.0" / 5.0" R = Reduced (See Pos. 7)	■	■	■
Position Housing Material & Port Type	3	S = 316 SS NPT L = 316 SS ANSI 150# RF Flanges H = Alloy-C NPT C = Alloy-C ANSI 150# RF Flanges	■	■	■
Position Seal Configuration	4	2 = Single Internal Carbon/SiC 3 = Single Internal Teflon/SiC 4 = Double Carbon/SiC 5 = Lantern Ring Teflon Packing 7 = Lantern Ring Graphoil Packing	■	⊗	⊗
Position Motor Frame	5	0 = NEMA 56C/56HC (Close-Coupled) 1 = NEMA 143TC/145TC (Close-Coupled) 5 = NEMA 182TC/184TC (Close-Coupled) P = Power Frame	■	■	■
Position O-rings/Gaskets	6	0 = Teflon V = Viton G = Graphoil	■	■	■
Position Impeller Trim (Standard)	7	0 = No Trim (Pos. 2 = F) 1 = 3.50" / 4.5" / 4.5" (Pos. 2 = R) 2 = 3.25" / 4.0" / 4.0" (Pos. 2 = R) 3 = 3.00" / 3.5" / 3.5" (Pos. 2 = R) 4 = 2.75" / 3.0" / 3.0" (Pos. 2 = R)	■	■	■

MAG-DRIVE Pump Sample Model No. **622 R S E B 1 2 V F 2**

Position No. 1 2 3 4 5 6 7 8 9 10

Position Model	1	MAG-DRIVE Pump Model	620	621	622
Position Impeller Diameter	2	F = Full - 3.75" / 5.0" / 5.0" R = Reduced (See Pos. 10)	■	■	■
Position Housing Material & Port Type	3	S = 316 SS NPT L = 316 SS ANSI 150# RF Flanges H = Alloy-C NPT C = Alloy-C ANSI 150# RF Flanges	■	■	■
Position Bearings	4	2 = Carbon 3 = Teflon B = Silicon Carbide E = Carbon 60	⊗	⊗	⊗
Position Thrust Washers	5	2 = Carbon 3 = Teflon B = Silicon Carbide E = Carbon 60	⊗	⊗	⊗
Position Motor Frame (Outer Magnet Bore)	6	0 = NEMA 56C/56HC (0.625") 1 = NEMA 143TC/145TC (0.875") 2 = IEC 71 - B5 (14 mm) 3 = IEC 80 - B5 (19 mm) 4 = IEC 90 - B5 (24 mm) 5 = NEMA 182TC/184TC (1.125")	■	■	■
Position Shaft Coating	7	1 = Chrome Oxide 2 = Tungsten Carbide	■	■	■
Position O-Rings/Gaskets	8	0 = Teflon V = Viton G = Graphoil	■	■	■
Position Magnetic Coupling	9	D = (MCD) 33 in-lbs F = (MCF) 120 in-lbs W = (MCW) 200 in-lbs	■	⊗	⊗
Position Impeller Trim (Standard)	10	0 = No Trim (Pos. 2 = F) 1 = 3.50" / 4.5" / 4.5" (Pos. 2 = R) 2 = 3.25" / 4.0" / 4.0" (Pos. 2 = R) 3 = 3.00" / 3.5" / 3.5" (Pos. 2 = R) 4 = 2.75" / 3.0" / 3.0" (Pos. 2 = R)	■	■	■

620 SEALED

620-MC MAG-DRIVE



CENTRY-SERIES
CENTRIFUGAL PUMPS



Sealed, Close-Coupled



Mag-drive, Close-Coupled

Port Connections:		
Suction	1.00" NPT/FLG	
Discharge	0.75" NPT/FLG	
Impeller Diameter	3.75"	
Impeller Trims (standard)	3.50", 3.25", 3.00" & 2.75"	
Max Flow Rate	45 GPM	
Max Total Head	65 ft	
Max Discharge Pressure	300 PSI	
Max Temperature	500 °F	
Min Temperature	-40 °F	
NPSHR @ 3500 RPM & BEP	7.5 ft	
NPSHR @ 1750 RPM & BEP	2.0 ft	
Pump Weights: (less motor)	NPT	FLG
Sealed, Single Int. Mech.	16 lbs	20 lbs
Sealed, Packing & Dbl. Mech.	26 lbs	30 lbs
Mag-Drive	30 lbs	34 lbs

620 SEALED

Dimensional data - inches

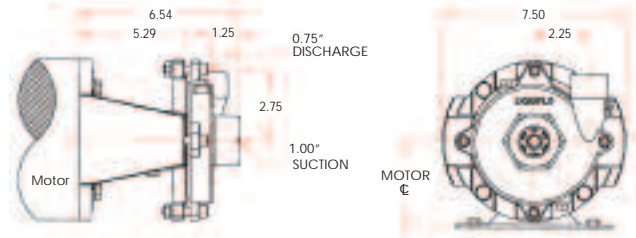

620 MAG-DRIVE

Dimensional data - inches

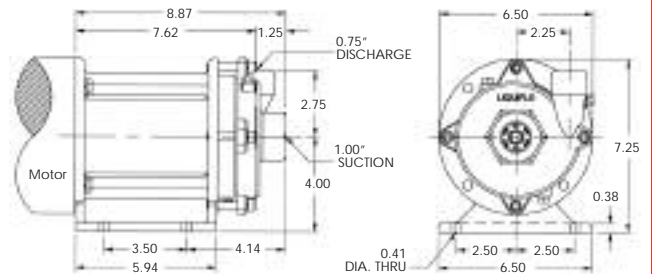

CENTRY MODEL 620 TYPICAL PERFORMANCE CHARACTERISTICS

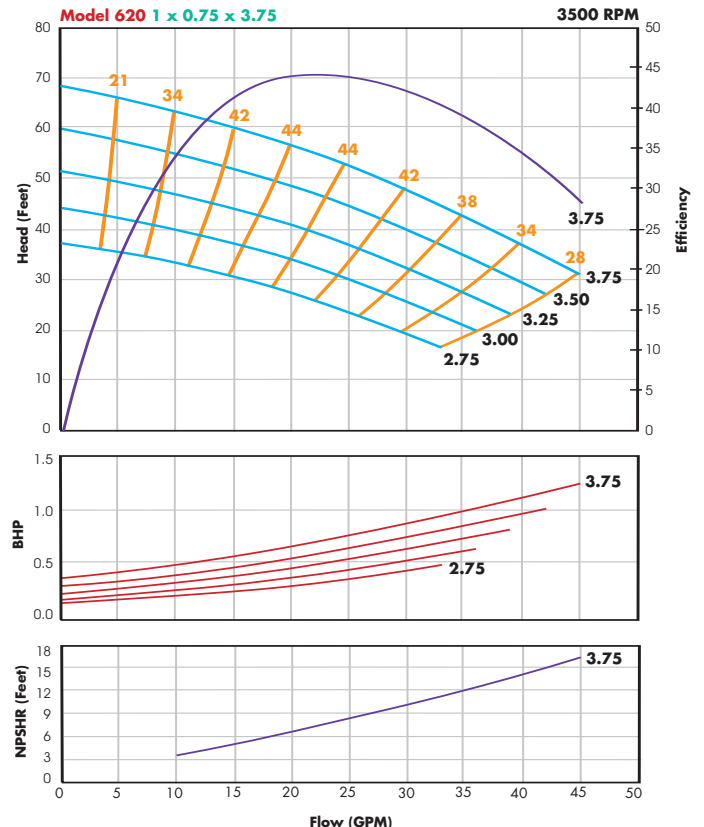
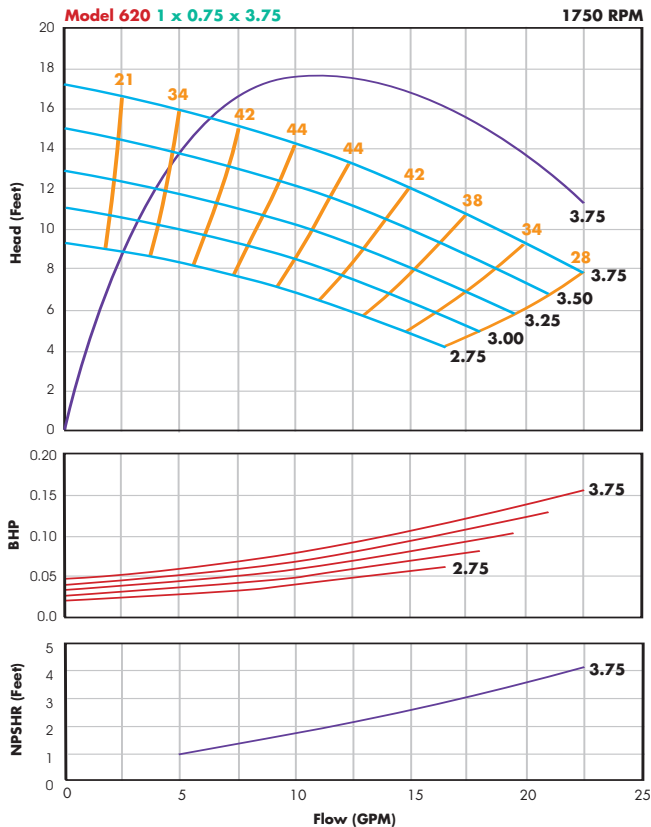

621 SEALED 621-MC MAG-DRIVE



CENTRY-SERIES
CENTRIFUGAL PUMPS

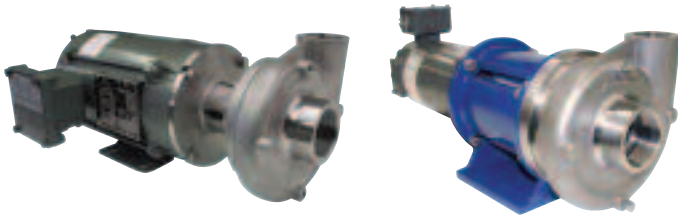

Sealed, Close-Coupled

Mag-drive, Close-Coupled

Port Connections:	
Suction	1.25" NPT/FLG
Discharge	1.00" NPT/FLG
Impeller Diameter	5.0"
Impeller Trims (standard)	4.5", 4.0", 3.5" & 3.0"
Max Flow Rate	90 GPM
Max Total Head	100 ft
Max Discharge Pressure	300 PSI
Max Temperature	500 °F
Min Temperature	-40 °F
NPSHR @ 3500 RPM & BEP	15 ft
NPSHR @ 1750 RPM & BEP	3.7 ft
Pump Weights: (less motor)	
Sealed, Single Int. Mech.	NPT 17 lbs FLG 23 lbs
Mag-Drive	42 lbs 48 lbs

621 SEALED

Dimensional data - inches

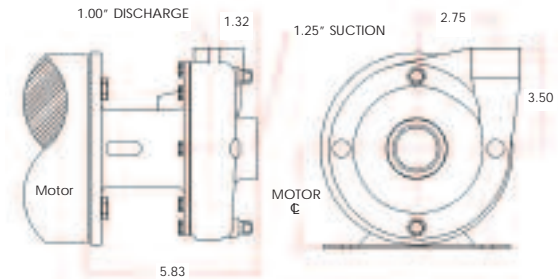

621 MAG-DRIVE

Dimensional data - inches

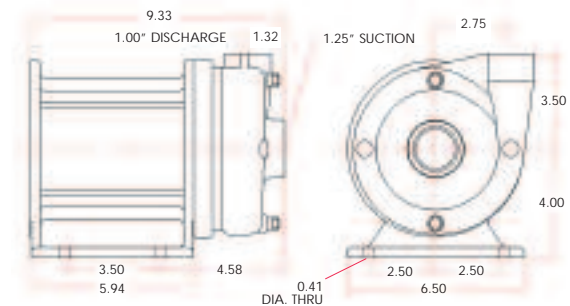

CENTRY MODEL 621 TYPICAL PERFORMANCE CHARACTERISTICS

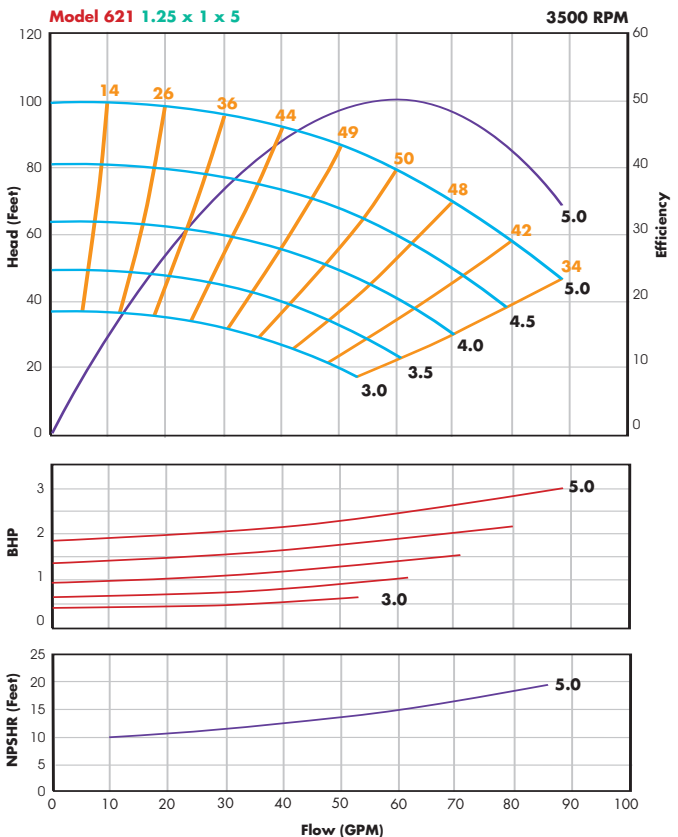
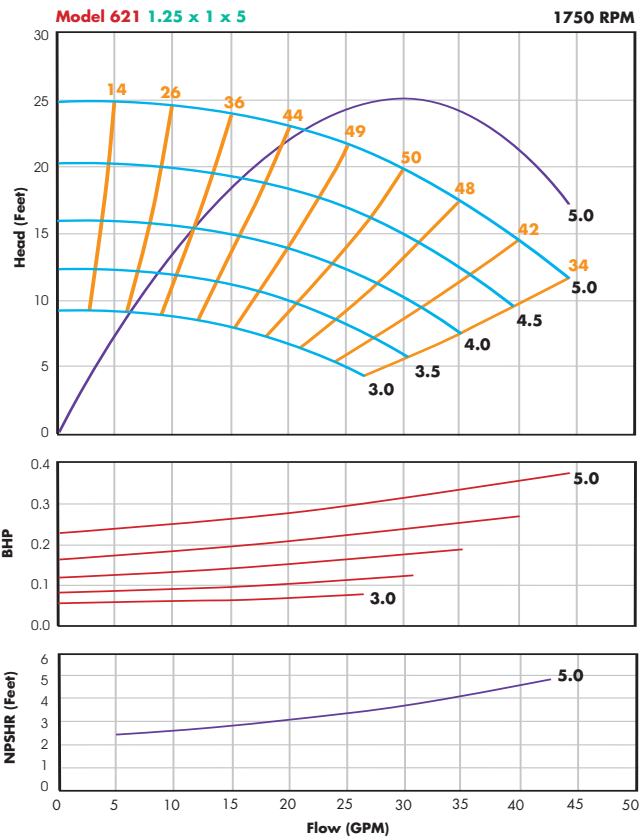

622 SEALED 622-MC MAG-DRIVE

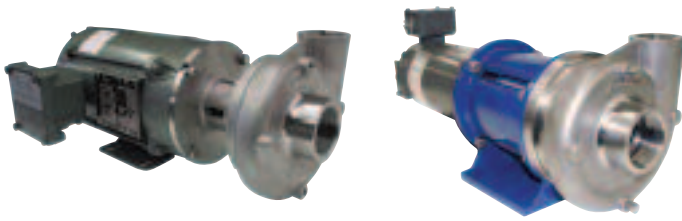

Sealed, Close-Coupled

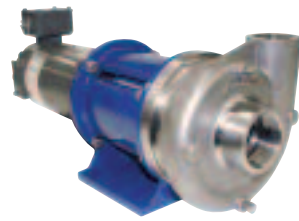

Mag-drive, Close-Coupled

Port Connections:	
Suction	2.0" NPT/FLG
Discharge	1.5" NPT/FLG
Impeller Diameter	5.0"
Impeller Trims (standard)	4.5", 4.0", 3.5" & 3.0"
Max Flow Rate	160 GPM
Max Total Head	95 ft
Max Discharge Pressure	300 PSI
Max Temperature	500 °F
Min Temperature	-40 °F
NPSHR @ 3500 RPM & BEP	13 ft
NPSHR @ 1750 RPM & BEP	3.2 ft
Pump Weights: (less motor)	
Sealed, Single Int. Mech.	NPT FLG
Mag-Drive	22 lbs 30 lbs
	48 lbs 56 lbs

622 SEALED

Dimensional data - inches

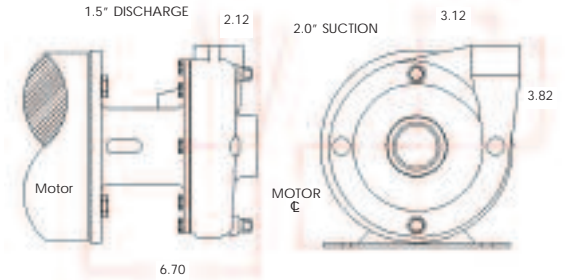

622 MAG-DRIVE

Dimensional data - inches

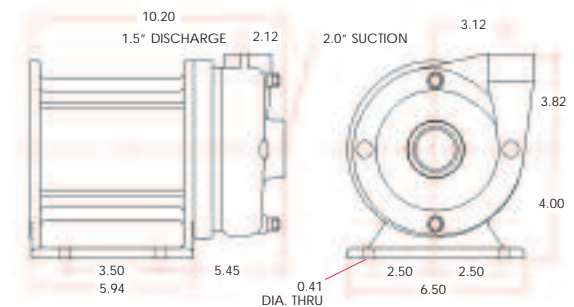

CENTRY MODEL 622 TYPICAL PERFORMANCE CHARACTERISTICS

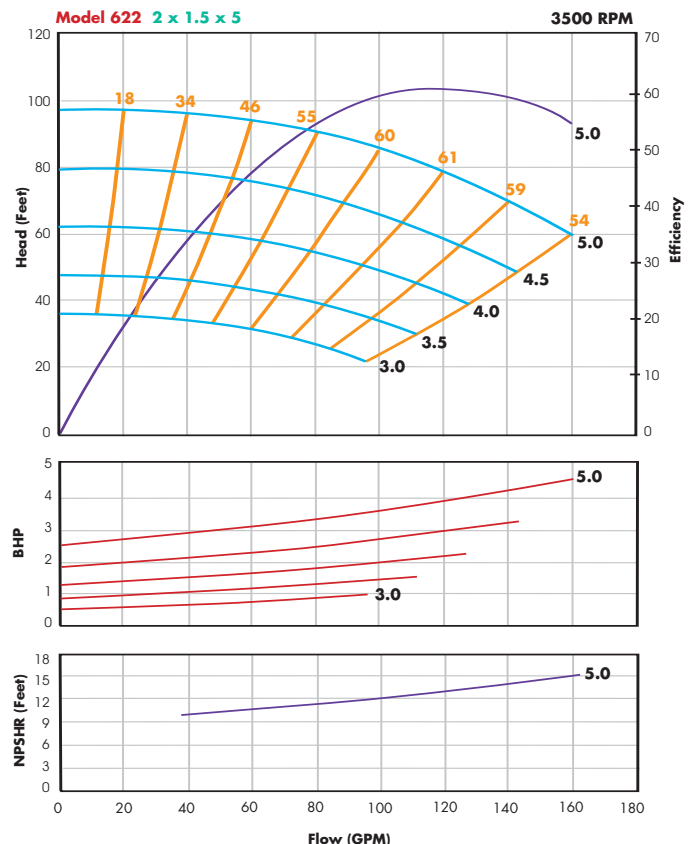
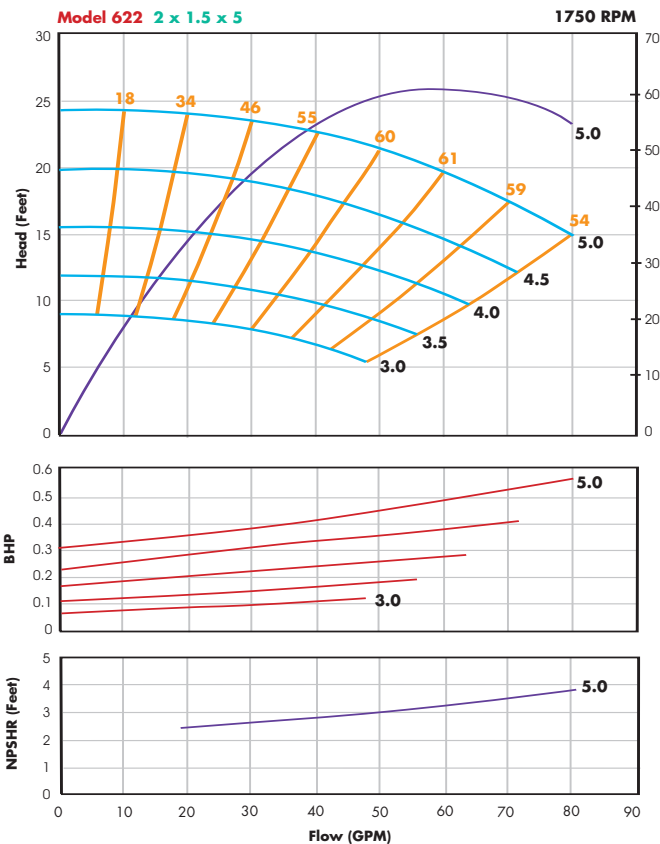

SPECIALTY PUMPS

SPECIALS

One of Liquiflo's many strengths is the ability to design and manufacture Specialty Pumps. A Special Pump can be as simple as modifying a port configuration or as complex as a complete new pump design. Liquiflo's design and manufacturing engineers use their years of pumping experience and knowledge of engineered materials to custom design pumps to meet specific applications. To date, Liquiflo has designed close to 900 different specialty pumps which have solved numerous problems in the chemical and industrial marketplace throughout the world.

If you have an application that cannot use a standard off-the-shelf pump, please give us the opportunity to design a custom pump that will meet the specific needs of your application.

A few examples of Liquiflo's custom designed pumps are described and shown on pages 84 & 85.

Liquiflo Can Custom Engineer Pumps to Meet Your Specific Requirements

"High Viscosity" Pump

Challenge: To pump a mastic with a viscosity similar to caulking at a differential pressure up to 500 PSI and suction pressure of 1000 PSI. The pump needed to be mounted on a 4-axis robotic head where it needed to discharge a bead of mastic at a maximum rate of 17 linear feet per second. In order to keep the inertia to a minimum, the pump needed to weigh less than 10 lbs.

Solution: A variation of the 37 Series pump was used. The pump casings were made of aluminum to help minimize the weight. The internal construction was: hardened steel gears, wear plates and shafts, sintered bronze bearings isolated from the pumpage by polypac seals and externally grease lubricated. The pump was close-coupled to a hydraulic motor and operated at a maximum speed of 50 RPM. From design to shipment, the working prototype was completed in just under eight weeks, and full-scale production was completed within sixteen weeks.

"Ultra-High Pressure" Mag-Drive Pump

Challenge: Custom requirements were for a mag-drive pump that could handle system pressures up to 1500 PSI (100 bar).

Solution: The containment can and housings had to be designed to withstand the unusually high pressure without catastrophic failure or distortion that would affect operating characteristics. A solid 316 SS bar stock body with extra heavy bolting was used in conjunction with an extra heavy-walled containment can to withstand the extremely high pressures. Test pressures of the newly designed pump exceeded 4500 PSI (300 bar). From design to shipment, the working prototype was completed in under ten weeks.

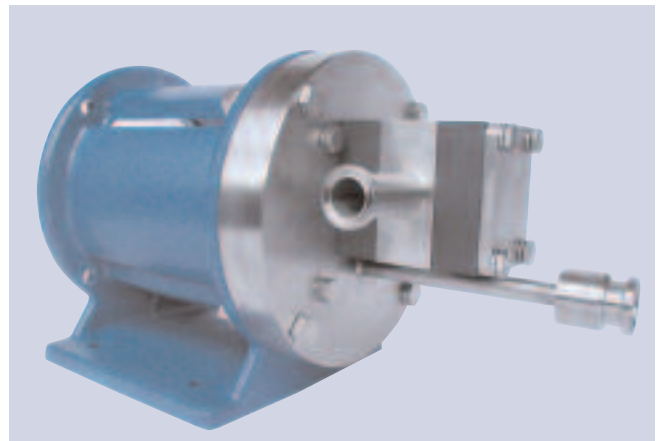
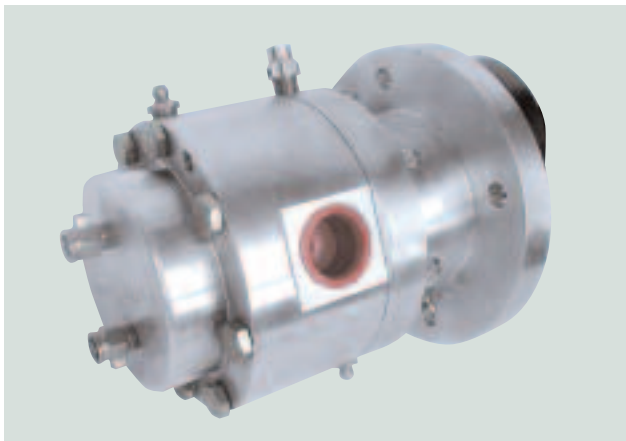



Challenge Us

With Your

Toughest

Pumping

Applications

"Glove Box" Nuclear Pump

Challenge: A pump was required for processing high-grade plutonium. The pump needed to be mounted inside the "glove box." The motor would be mounted on the outside of the glove box and the pump would be mounted on the inside of the glove box. In addition, due to the radioactivity of the material being pumped, a further requirement was to have the ability to remove the pump cartridge and/or the motor, without creating a breach in the glove box wall.

Solution: A double containment shell solved the problem. One containment can was mounted to the pump in the normal manner while the second containment can was mounted to the glove box wall. This configuration maintained closure in the event that either the pump or the motor needed to be removed for repair or replacement.

"Bromine" Plastic Gear Pump

Challenge: The requirement was to pump pure liquid bromine at a differential pressure of 30 PSI.

Solution: This is one of a number of gear pumps that Liquiflo made from plastic. This pump in particular was a Kynar version of a 35 mag drive with Kynar coated inner magnet and containment can, tantalum shafting, and unfilled Kynar housings. (Other engineered plastics that Liquiflo has manufactured gear pumps from include CPVC for herbicide service, PTFE for ultra pure water service and Ryton for various services.)

"Super Bullet" (Colloidal Suspension) Pump

Challenge: The requirement was to build a non-pulsing positive displacement pump for pumping water containing colloidal silica for the paper industry. The colloidal silica particles are extremely abrasive and small in size – just 2-10 microns. These abrasive particles work their way into the smallest of crevices and accelerate wear of surfaces that exhibit any relative motion. The customer found it impossible to find a pump that would last more than a few weeks in this extremely difficult service.

Solution: Liquiflo's designers solved this challenging application using a variety of engineered materials that would work well together even in an extremely abrasive environment. They also redesigned the internal configuration of the pump to minimize the abrasive action that normally takes place. After an extended effort, the chosen materials for the internals of the pump were SiC on SiC bearings, and bearing-grade PEEK gears. A small amount of carbon graphite was added to the inner SiC sleeve bearing to give it some self-lubricating properties. With a service life now in excess of 12 months, our satisfied customer respectfully nicknamed it the "Super Bullet."

