

LINATEX®
Rubber Products

Linatex Hose Range

Excellent
Minerals
Solutions

WEHR
MINERALS

motralec

4 rue Lavoisier . ZA Lavoisier . 95223 HERBLAY CEDEX
Tel. : 01.39.97.65.10 / Fax. : 01.39.97.68.48
Demande de prix / e-mail : service-commercial@motralec.com
www.motralec.com

Our hose systems are expertly built to deliver outstanding wear performance in the most demanding applications.



Weir Minerals collective global experience and expertise in the design and manufacture of custom-made material handling hose is second to none.

Built to deliver outstanding wear performance in the most demanding applications, our hose products have rightly won a reputation for reliability and long wear life. They are industry compatible with a wide range of processing plants, and are fitted as standard equipment to many leading systems across the globe.



Our specialty hose range incorporates slurry and chemical mining hose, dredge hose and a wide variety of preformed bends, reducers and T-pieces all of which are available with a versatile array of end types. Our state-of-the-art computer controlled lathes ensure that the application of material in the hose construction is consistent. This makes for a high quality hose construction that is both robust and reliable.

When you choose to install our Wear Indicator technology, you are taking advantage of over 80 years experience, our cutting-edge technology and a step towards improving both the safety and environmental impact of your site.

With sites on every continent and a distribution network unparalleled in the industry, we can deliver application-engineered hose systems to you, wherever you are. Whenever you work with one of our local representatives, you are supported by the know-how of a global team.





Raw Materials

We believe that quality raw materials are the key to manufacturing premium specialty hose. When we design and custom build your hose, you can rely on receiving a superior wear resistant hose created with the highest quality rubber compounds, reinforcement cords and end connections.

Wear liner composition is critical to the performance of your hose. With over 80 years industry experience, we have the expertise to select the best composition for your specified application. Our extensive knowledge of wear performance compounds ensures that our products are built to last.

Our hoses are created using traditional reinforcement materials such as nylon or polyester. Alternate materials, such as Kevlar, may also be used. Reinforcement cord materials are selected to complement our designs during the engineering process.

Innovation

Our engineers lead the way in technological advancements, constantly improving our hose products to make your job easier. For example, our unique Wear Indicator technology for hose is a wireless early warning system that alerts operators to hose wear in highly abrasive materials handling applications. The technology ensures that environmental spills, costly emergency downtime, and health and safety incidents are significantly reduced or eliminated.

Design Features

The unique red Linatex® premium rubber compounds provide your project with proven superior wear resistance and extended wear life. This ensures that the lowest total cost of ownership is realized.

Our entire hose range is supported by our extensive technical and design facilities. This allows for full customization to meet your specific requirements which, in turn, reduces commissioning and installation inefficiencies.

Our specialty hose range features:

- Various hardnesses and compounds to suit specific applications
- A variety of standard and custom-made bore sizes and lengths
- Specialized end fittings to suit individual applications
- Custom branding and/or color coding to ensure full and clear identification
- Our Hose Audit Service providing on site evaluation/ review of all hose issues including suitability and safety
- Independent testing facilities (if required)
- Support by our experienced field representatives who provide on site assessment and advice
- Cutting-edge Wear Indicator technology ensuring critical hose monitoring confidence



The Right Hose for the Job

We understand that each of our customers has unique needs and specific requirements. We will work closely with you to ensure that you achieve the best hose solution for your site. We will custom-design to any size, with hose diameters in excess of 1 m/40 in and lengths up to 15 m/50 ft.

Our hoses are designed to accommodate standard or custom flange types. Other options include built in nipples, victaulic end connections and plain or cuffed ends. We custom manufacture to nominated length and engineer to required pressure. We also offer a variety of compounds and wear liner gauges to best suit the duty.

Specialty Hose Range

Our specialty hose range includes:

Hard Wall Mining Hose (808)

- Acid/Chemical Hose (700)
- Cut End Hose and Split Cast Couplings
- Smooth Cut End Hose (801)
- Corrugated Cut End Hose (800)
- Aluminium and Cast Iron Couplings

Soft Wall Mining Hose (806)

Dredge Hose (1000)

- Discharge Dredge Hose
- Gimble and Trunnion Hose
- Dredge Sleeves
- Custom designs by request

Flexible Connectors

- Preformed Hose Bends
- Reducers and Tapers
- Adaptors
- Expansion Pieces

We pride ourselves on delivering total hose solutions. We are also able to supply an extensive array of complementary hose products.

Please Note: Not all items are available in all regions. Please contact your local representative for more details and information.

Polymers and Liners

LINATEX® Natural Rubber Compounds

LINATEX® premium rubber

LINARD® Compounds

Linard 60

Linard HDS

Linard HD70

LINAGARD® Compounds

Nitrile

Neoprene OSR

Other Compounds

Natural/SBR

EPDM

Hypalon

Neoprene

Butyl

Natural and synthetic blends used. Other compounds available on request.

Hard Wall Mining Hose* (808)

The Hard Wall Mining Hose (808) range of custom hoses is designed for the most arduous of mining and industrial duties.

Built for suction and discharge applications, these robust hoses are manufactured with a heavy spring steel wire helix, designed to cater for high dynamic loads.

Hard Wall Mining Hose 808 can also be adapted for aggressive acid or chemical applications through the addition of Linatex® premium rubber liners.

Hard Wall Mining Hose 808 can be custom manufactured to any size and are available with a broad array of flange types.

* Hard Wall Mining Hose (808) is also suitable for heavy duty industrial applications.



Soft Wall Hose (806)

The Soft Wall Hose (806) range allows for moderate flexibility and is preferred in applications where the hose is moved frequently. The non-wire construction reduces the occurrence of internal damage caused by over bending.



Cut End Hose and External Reusable Couplings

The Cut End Hose coupling arrangement is designed as an 'off-the-shelf' hose system developed to minimize both down time and maintenance costs. Combining the outstanding abrasion resistance of a uniform wear tube with lightweight reusable aluminium flanged couplings, this unique combination allows fast and easy on site assembly.

The hose coupling system is not exposed to the material flow and is therefore suitable for abrasive and corrosive duties. The couplings are available with 150# bolt pattern in aluminum and accommodate standard industry operational pressures.

Our Cut End Hose is available in both smooth and corrugated form.



Dredge Hose

Globally regarded as the industry leader in abrasion resistant rubber compounds, we now also have the enviable reputation as a global supplier of quality dredge hoses with a difference.

Our reputation for quality wear performance dredge hose is why our hose has been trusted by many dredge operators and used on many of the world's leading dredges.

With years of compounding experience behind us, and expert, in-house engineers available to work with you, we are confident that we will provide a dredge hose solution to meet your specific requirements.

The Dredge Hose range includes both suction and discharge dredge hoses, dredge ladder hoses and dredge sleeves. Other designs are also available.



Minimum Bends Radius

The bend radius (r) is the radius of the arc through which a hose is bent. The minimum bend radius is the tightest arc in which a hose can be bent without kinking or otherwise damaging the hose. Bending a hose to a tight radius imposes stresses on the structure of the hose that may cause a reduction in the performance, or in extreme cases permanent damage to the hose.

The minimum bend radius that a hose will withstand depends upon many factors including the wall thickness, the presence of a wire helix, the type of reinforcing material and the loss of performance that can be tolerated.

For those applications where a tighter bend radius is required, a special hose construction is employed when the bend radius is less than eight times the hose's nominal bore. Hoop construction is also employed where robust flexible hose is required.

Preformed Hose Bends

Similar in construction to our Hard Wall Hose, our Preformed Hose Bends are intended for use where space limitations demand a much sharper bend radius than can be achieved using a length of Hard Wall Hose (808).

Designed to offer superior wear performance over normal hose and steel lined pipe, we provide these in an extensive array of diameters, bend angles and radii configurations.



Reducers (Tapers) and Ancillary Items

Concentric and eccentric hose reducers are built for either suction or discharge duties and are custom manufactured to incorporate differing flange requirements.

They can be manufactured to incorporate flush points and designed to custom pressure and length requirements.

As your total hose solution provider, we also manufacture ancillary items such as T pieces, Y pieces, adaptors and expansion pieces.



Wear Indicator

Our unique, wireless Wear Indicator technology provides a complete solution to many of the problems that are faced in maintaining highly abrasive materials handling hose.

Our Wear Indicator technology eliminates the need for physical inspections and averts costly emergency downtime. Our technology also helps to prevent unexpected hose failure which can cause environmental spills and health and safety incidents.

The Wear Indicator technology even detects wear in hoses carrying conductive slurries, including those containing hyper-saline.

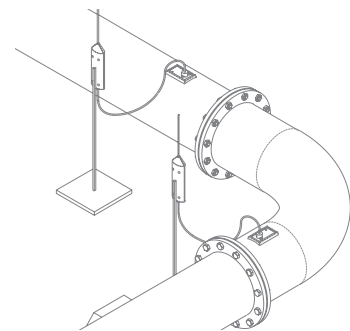

Hose End Types

Fixed Flange

Fixed Flange ends are recommended for hoses that have medium working pressures and subject to low stresses during application.

The rubber and fabric reinforcement of the hose body is extended to form a full face flange which is backed by a full circle or split ring metal backing plate.



Swivel Flange

Swivel Flange ends have the ability to rotate the backing flange, and are designed as an alternative to Fixed Flange ends. Swivel Flanges allow ease of alignment of the bolt holes.



Double Flanges

The Double Flange arrangement is designed for use on hoses subject to high axial loads. The twin steel flanges are built-in and able to withstand considerable bend loads while maximizing flexibility from the hose. The front flange is encapsulated in rubber and reinforcement cord, providing protection against corrosion.



Custom Couplings

Custom Couplings are fully rubberized, built-in couplings that are available in Swivel or Fixed Flange configurations. Custom Couplings are mainly used in dredging and high performance/pressure slurry applications.

The built-in coupling tail piece is adaptable to various fittings, including victaulic, rotating, Fixed Flanges and proprietary couplings.



Cut End and External Reusable Coupling

This two-piece External Coupling is designed for use on our Cut End Hose. The coupling does not come into contact with the internal hose flow, making it highly suitable for abrasive slurries.





Experience the Difference

We are proud to be the market leader. We set the international benchmark for rubber used for abrasive materials handling across all mining applications.

We are not just leading the way in the mining industry, we are also suppliers of premium hose and end fittings for other industries. Our Dredge Flex Hose is the equal of any dredge hose in the field. When our solution focused engineering capabilities are taken into consideration, we have become the **only** option when selecting dredge hose for your operation.

By imposing strict quality control measures and testing samples at every step of production, we ensure long lasting industrial wear solutions that are the most cost effective. With hose available in either renowned Linatex® premium rubber or a variety of compounds, we deliver the right hose for every job.

Superior design capabilities and build quality, as well as our customer service, is what sets our hose apart. When you invest in our hose, you get more than just a hose, you receive a product that is made from the best raw materials, custom engineered to your exact requirements and backed up by our ongoing, on site technical support.

Our unique Wear Indicator technology demonstrates our commitment to harnessing technological innovations to make your job easier and your site safer.

Global production facilities allow us to meet short manufacturing lead times and our extensive distribution network ensures prompt delivery, no matter where you are.

In a diverse range of materials handling applications, our hose products have proven to consistently outperform and outlast competitor products. To find out more, read about our in-the-field success stories at www.weirminerals.com

For more information about our specialty hose range, please refer to our comprehensive range of hose Product Specification Sheets or contact your local representative.



- WARMAN®** Centrifugal Slurry Pumps
- GEHO®** PD Slurry Pumps
- LINATEX®** Rubber Products
- VULCO®** Wear Resistant Linings
- CAVEX®** Hydrocyclones
- FLOWAY® PUMPS** Vertical Turbine Pumps
- ISOGATE®** Slurry Valves
- MULTIFLO®** Mine Dewatering Solutions
- HAZLETON®** Specialty Slurry Pumps
- LEWIS® PUMPS** Vertical Chemical Pumps
- WEIR MINERALS SERVICES™**





4 rue Lavoisier . ZA Lavoisier . 95223 HERBLAY CEDEX
 Tel. : 01.39.97.65.10 / Fax. : 01.39.97.68.48
 Demande de prix / e-mail : service-commercial@motralec.com
www.motralec.com

Excellent
Minerals
Solutions



Copyright © 2011, 2012, Linatex Corporation of America. All rights reserved. WARMAN is a registered trademark of Weir Minerals Australia Ltd and Weir Group African IP Ltd; CAVEX, HAZLETON and MULTIFLO are registered trademarks of Weir Minerals Australia Ltd; LEWIS and LEWIS PUMPS are registered trademarks of Envirotech Pumpsystems Inc; GEHO is a registered trademark of Weir Minerals Netherlands bv; FLOWAY is a registered trademark of Weir Floway Inc.; VULCO is a registered trademark of Vulco SA; ISOGATE is a registered trademark of Weir do Brasil Ltda.; LINATEX and LINARD are registered trademarks of Linatex Ltd; LINAGARD is a trademark of Linatex Ltd; WEIR is a registered trademark of Weir Engineering Services Ltd. Certain features of the some of the products disclosed in this document are protected worldwide by patents pending and registered in the name of Linatex Australia Pty Ltd. HYPALON and VICTAULIC are not trademarks of any company forming part of The Weir Group PLC.