

motralec

4 rue Lavoisier . ZA Lavoisier . 95223 HERBLAY CEDEX
Tel. : 01.39.97.65.10 / Fax. : 01.39.97.68.48
Demande de prix / e-mail : service-commercial@motralec.com
www.motralec.com

LEWA
pumps + systems

LEWA process diaphragm pumps

For process engineering



- **safe**
- **hermetically tight**
- **reliable**
- **economical**
- **up to 1200 bar**

LEWA process diaphragm pumps



Low life cycle costs:
high overall efficiency, low energy
consumption and long service intervals



Maximum safety:
safe, even dry operation, safe against
overload and equipped with
diaphragm monitoring system



Technically at the top:
LEWA supplies the world's biggest process
diaphragm pumps

The LEWA process diaphragm pumps for high pressure process engineering are the standard for tightness in the high pressure range. Here also LEWA has set the standards and consistently further develops the diaphragm pump technology.

With LEWA process diaphragm pumps even critical, toxic or inflammable fluids can be conveyed safely. Also extremely low viscosity, non-lubricating fluids or abrasive suspensions are handled without any problems. The pressure range goes up to 1200 bar.

The advantages of LEWA process diaphragm pump at a glance:

- Hermetically tight, zero leakage
- Metal- or PTFE sandwich diaphragms with diaphragm monitoring system
- Compact monoblock design or variable modular design
- Safe dry operation and overload safe
- Sturdy and low maintenance requirements
- Precise conveying even at pressure fluctuations due to pressure stiff characteristic
- High efficiency
- High availability
- Low life cycle costs

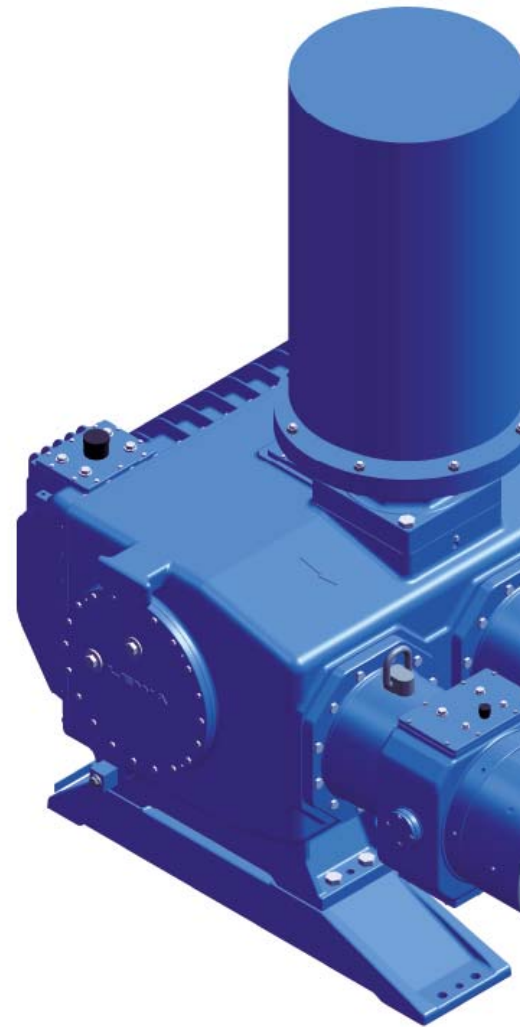

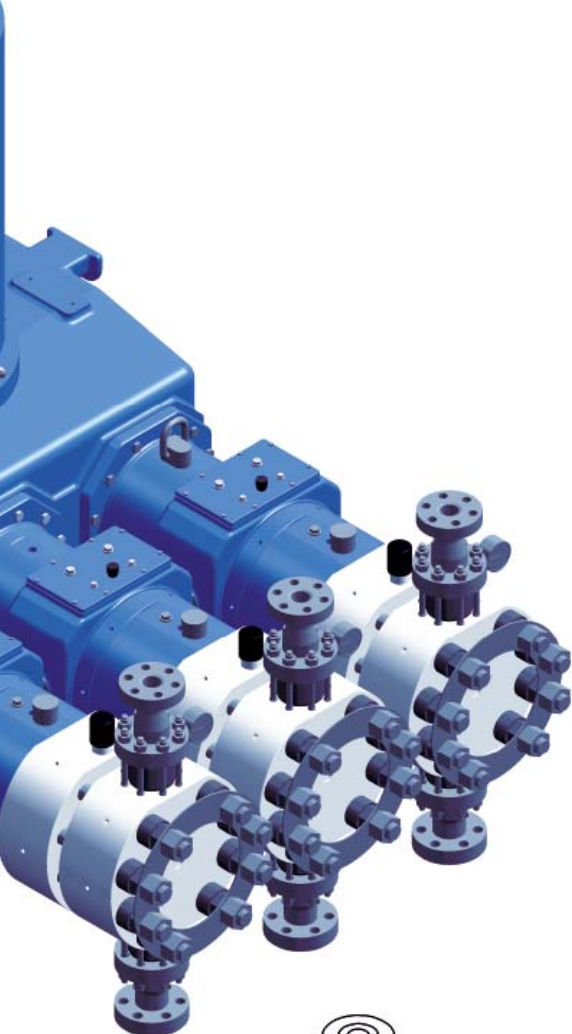

LEWA triplex:
monoblock design

Performance table

Pressure	up to 1200 bar
Flow rate	up to 0,1– 180 m ³ /h per pump head
Temperature	–80 to +200° C
Viscosity	from 0,1 up to 250.000 mPa s

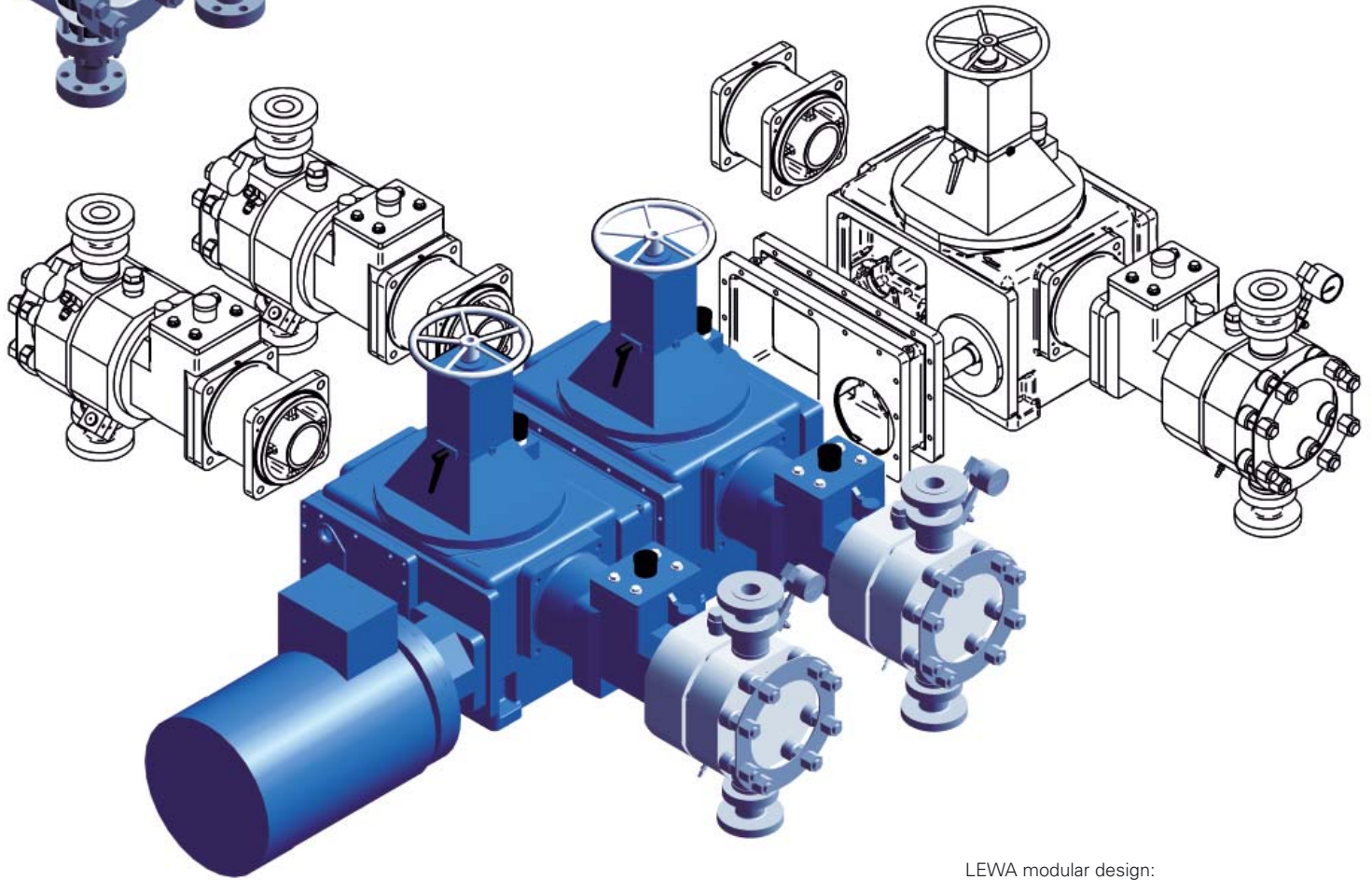

LEWA modular design:
variable modular design in serial and
boxer design

High performance with minimum foot print: The LEWA drive units



Even at remote locations: the LEWA service is available at any time and all over the world

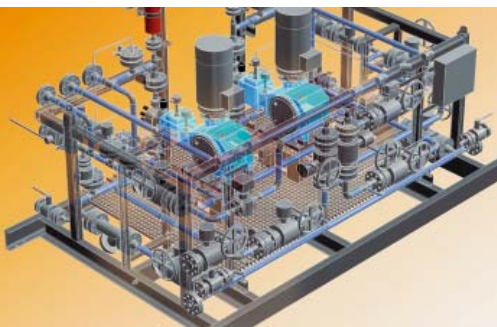

Ready for hook-up: LEWA process diaphragm pumps and systems are supplied ready for operation and with all required interfaces

LEWA process diaphragm pumps are available in the compact LEWA triplex series and in the segment design LEWA modular.

LEWA triplex (monoblock)

The LEWA triplex drive units are carried out in monoblock design.

- Extremely space- and weight saving monoblock design
- Solid, sturdy overall design
- Extremely smooth and low-vibration running due to equal eccentric shifting
- Sturdy friction bearings for eccentric and rod bolt
- Integrated worm gear and vertical flange motor up to G3R frame size
- Low pulsation due to overlapping partial flows
- Precise, reproducible flow setting via speed

LEWA modular design

With this very flexible programme the most different customer requirements can be met economically.

- Especially for mixture control and strongly varying flows
- Wide control range up to 1:100
- Precise, reproducible flow setting via stroke length and speed
- For conveying tasks conveyed with metering tasks
- Solid overall construction
- Up to six individual elements, even different frame sizes, can be combined
- Economic duplex-, quadruplex- or sextuplex pumps in boxer design (GSB, ESB, LDHB and LGB)

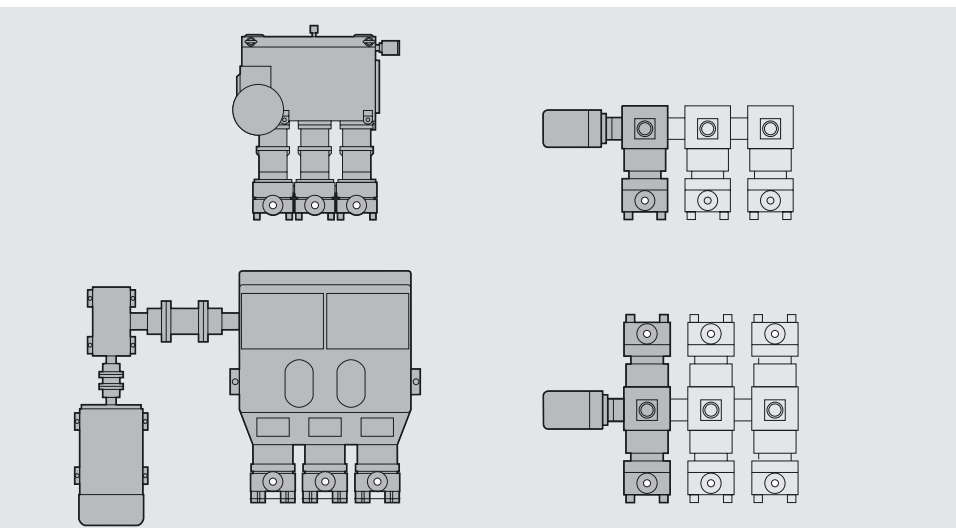

High performance: compact monoblock design or variable segment design

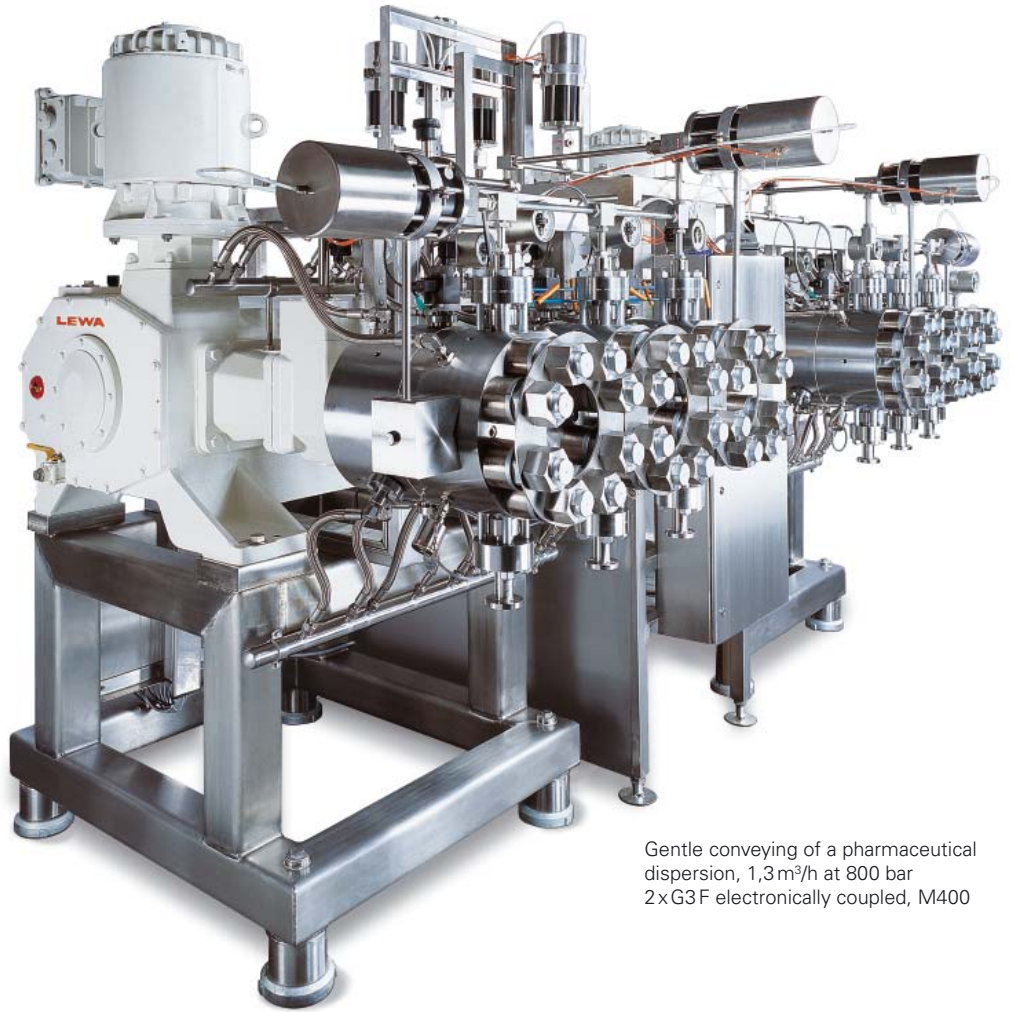

Gentle conveying of a pharmaceutical dispersion, 1,3 m³/h at 800 bar
2xG3F electronically coupled, M400



Versatile solutions:
e.g. fully heated
plunger pump heads
and valves for melts



Example upstream oil & gas industry:
methanol injection, 8,8 m³/h at 345 bar,
M500 for hydrate-formating protection

Maintain hermetic tightness: LEWA diaphragm pump heads

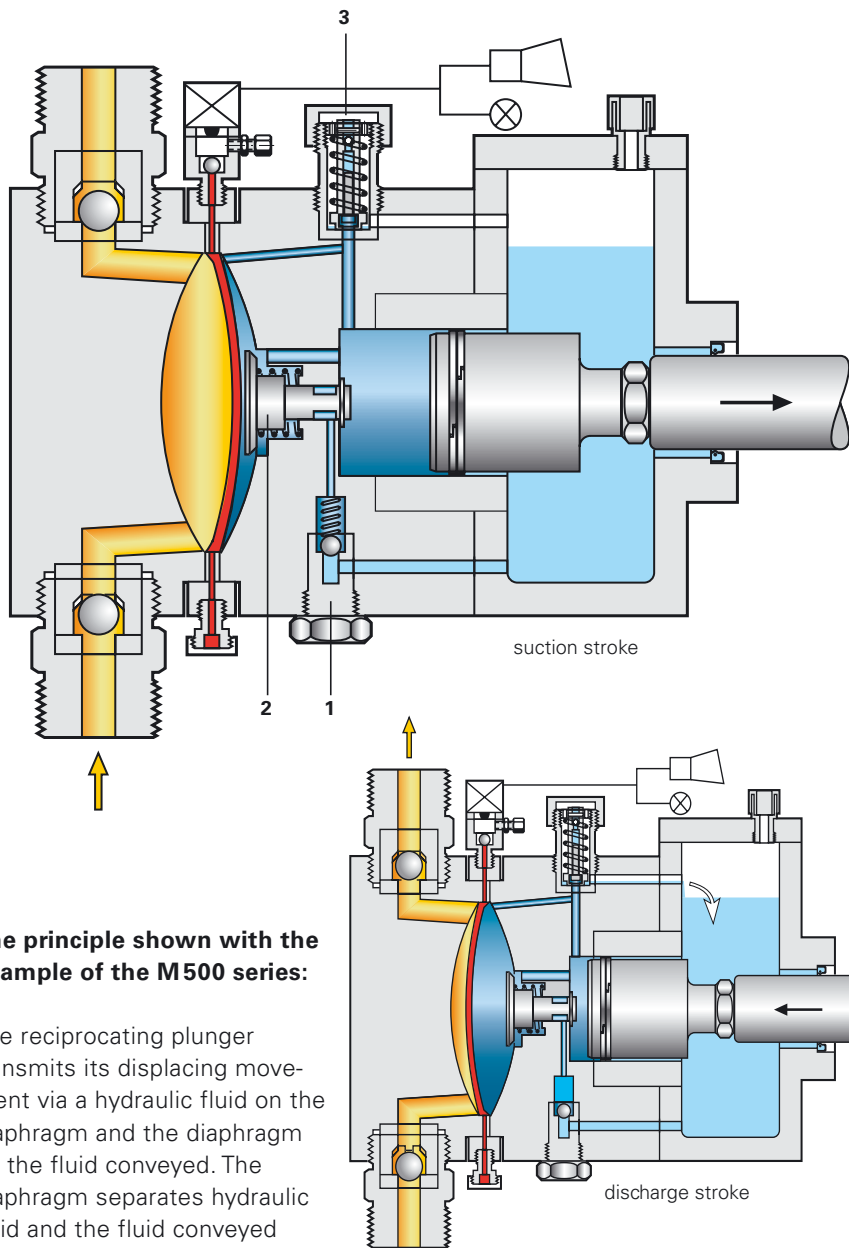

The principle shown with the example of the M500 series:

The reciprocating plunger transmits its displacing movement via a hydraulic fluid on the diaphragm and the diaphragm on the fluid conveyed. The diaphragm separates hydraulic fluid and the fluid conveyed and safely separates them from the atmosphere. A diaphragm movement control in the hydraulic part of the pump head assures highest operational safety. Via the snifting valve (1) in connection with the control push rod (2) the rear diaphragm position is determined and the internal leakage is replenished. An integrated pressure limiting valve (3) with degassing function safeguards the pump against overload.

LEWA diaphragm pump allow safe and hermetically tight conveying at medium up to high pressures.

LEWA diaphragm pump heads are an economical solution for a variety of metering- and conveying tasks. Environmentally damaging, dangerous, sensitive or abrasive fluids are therefore only conveyed with zero-leakage pump today.

Sandwich diaphragms with diaphragm monitoring system are the standard design of all LEWA diaphragm pumps. Damage of the diaphragm is reliably indicated. The pump still remains tight and operation can be continued for a limited period of time. LEWA diaphragm pumps are protected against overload by an integrated pressure limiting valve.

Advantages of LEWA diaphragm pump heads

- Highly economical
- Hermetically tight, zero leakage
- Durable sandwich diaphragm with diaphragm monitoring system
- Protected against overload by adjustable pressure limiting valve
- Minimum maintenance costs due to low-wear components
- Absolute safe dry operation
- High metering accuracy by pressure stiff, linear pump characteristics and hydraulic degassing
- Separation of hydraulic and drive element oil
- Gentle conveying of sensitive fluids
- Online and offline condition monitoring systems for electronic monitoring

Universal with high performance: Diaphragm pump head M500

The universal series with PTFE sandwich diaphragm suitable for practically any metering and conveying application.

Due to the revolutionary diaphragm position control highest operational safety can be achieved even for fluids difficult to handle, e. g. suspensions or highly viscous fluids.

Advantages of the M500 series

- Universal application
- Insensitive to particles suitable for suspensions and high viscosity fluids
- Long diaphragm service life due to hydraulic diaphragm position control
- Suction pressure safe up to 350 bar by full rear diaphragm support
- Unobstructed flow channels in the operating chamber as diaphragm oscillates freely
- Internal protection against over-pressure
- Standard materials for wetted parts is 1.4571 (316Ti) with high chemical resistance

Options

A high number of special designs allows to meet almost every process requirement:

- Special valves
- Many connection options
- Diaphragm condition monitoring systems using pressure switches, pressure gauges and contact pressure gauges and pressure transmitters
- Heating and cooling jacket
- Pump heads with overall heating jacket for melts
- Easy clean pump heads (CIP)
- Special materials, e. g. Hastelloy, titanium, duplex steel
- Hygienic designs for food stuffs, pharmaceutical and bio-technology applications
- 3A-approval

Performance table

Pressure	up to 350 bar
Flow rate	up to 50 m ³ /h per pump head
Temperature	-50 to +150° C
Viscosity	up to 100.000 mPa·s

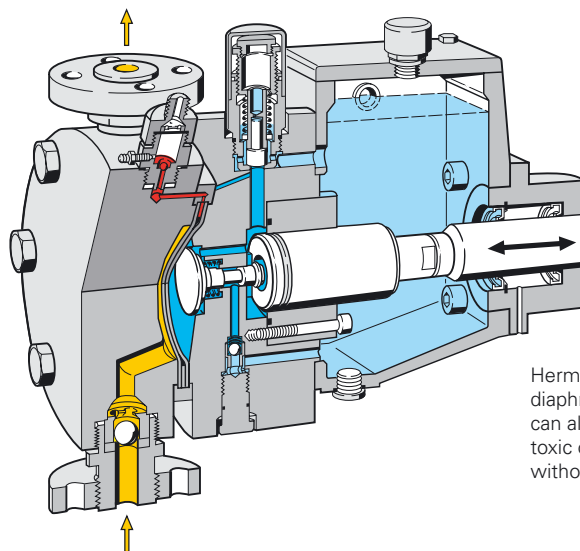

Hermetically tight: diaphragm pump heads can also be used for critical, toxic or inflammable fluids without problems

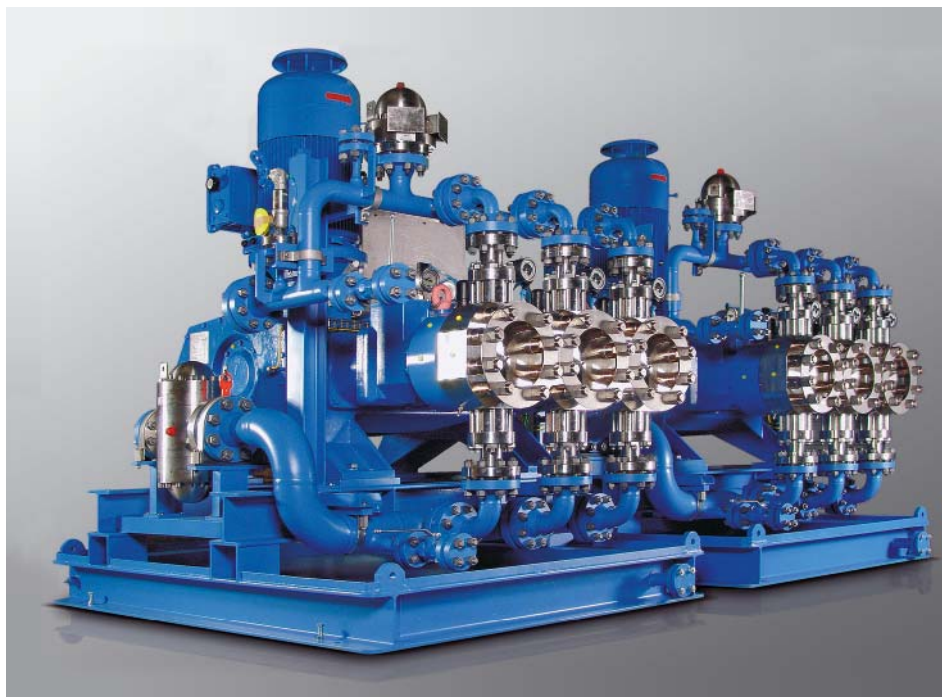

Extremely wide application range: diaphragm pump heads are suitable for nearly all fluids

For high pressure and high performance: Diaphragm pump head M800

Performance table

Pressure	up to 800 bar
Flow rate	from 130 l/h – 20 m ³ /h per pump head
Temperature	–20° C to +80° C
Viscosity	up to 100.000 mPa s

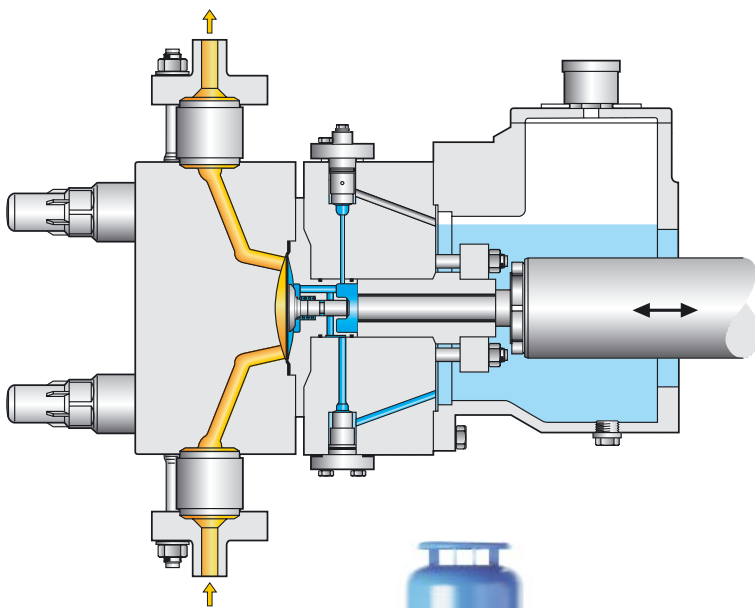

Conveying at high pressure:
e. g. high pressure atomisation
G3S, M800, 700 bar

The high pressure diaphragm pump heads of the M800 series represent an extension of the proven M500 series with a discharge pressure up to 800 bar. Due to an integrated diaphragm monitoring system in combination with a PTFE sandwich diaphragm high process safety is guaranteed. With this series the use of zero-leakage diaphragm pumps, exceeding the present pressure limits of plastics diaphragms, is considerably more economical than using metal diaphragm pump heads.

Advantages of the M800 series

- Maximum pressure 800 bar
- Temperature range –20° C to +80° C
- Hermetically tight system
- High process safety due to diaphragm monitoring system
- Long diaphragm service life
- Low life cycle costs due to wear-free plunger seals and long diaphragm service life
- Suitable also for difficult fluids e. g. suspensions with hard particles or fluids with high viscosity
- High suction ability due to diaphragm position control
- Safe against high suction pressure by full rear diaphragm support
- Safe against overload of the pump by integrated pressure limiting valve in the hydraulic part

Options

- Special valves
- A variety of connection dimensions
- Heating and cooling equipment
- Easy to clean pump heads (CIP)
- Hygienic designs for food stuffs, pharmaceutical and bio-technology applications
- Special materials

For high pressure up to 1200 bar: Diaphragm pump heads M400

The high pressure pump series with metal diaphragm for high pressures and high temperatures.

Diaphragm pumps with metal diaphragm are used when high pressures or high temperatures must be handled or when high diffusion resistance is required. This series offers extremely high safety standards by limiting the diaphragm deflection in both directions so that diaphragm overload by faulty operation is safely prevented. A big safety plus is offered by the sandwich diaphragm at pressures of up to 1200 bar.

Advantages of the M400 series

- Very high safety standard
- Protected against diaphragm overload and faulty operation
- Suction pressure proof up to full operating pressure at rest, up to 100 bar in operation
- Diaphragm absolutely diffusion tight
- Long diaphragm service life by even deflection via support plate on hydraulic side and protection against excessive diaphragm deflection

Performance table

Pressure	up to 1200 bar
Flow rate	from 1 l/h to 5 m ³ /h per pump head
Temperature	up to +200 °C
Viscosity	up to 500 mPa s

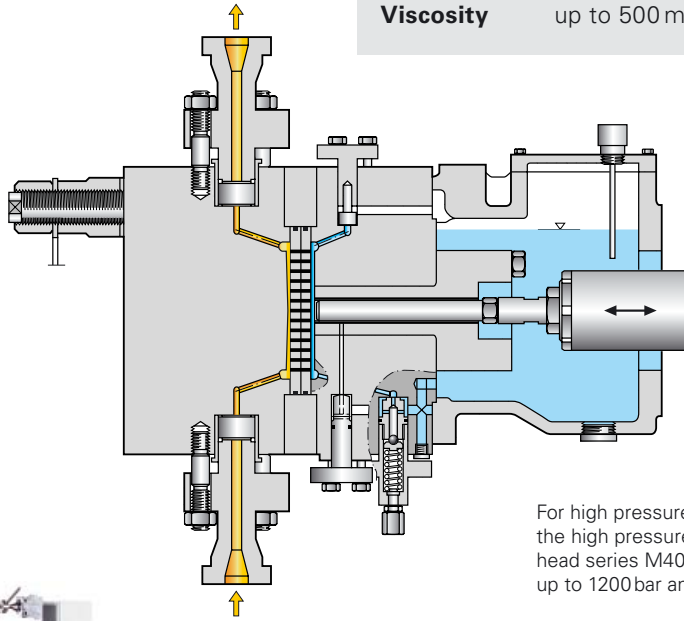

For high pressure:
the high pressure pump
head series M400 is used
up to 1200 bar and 200 °C

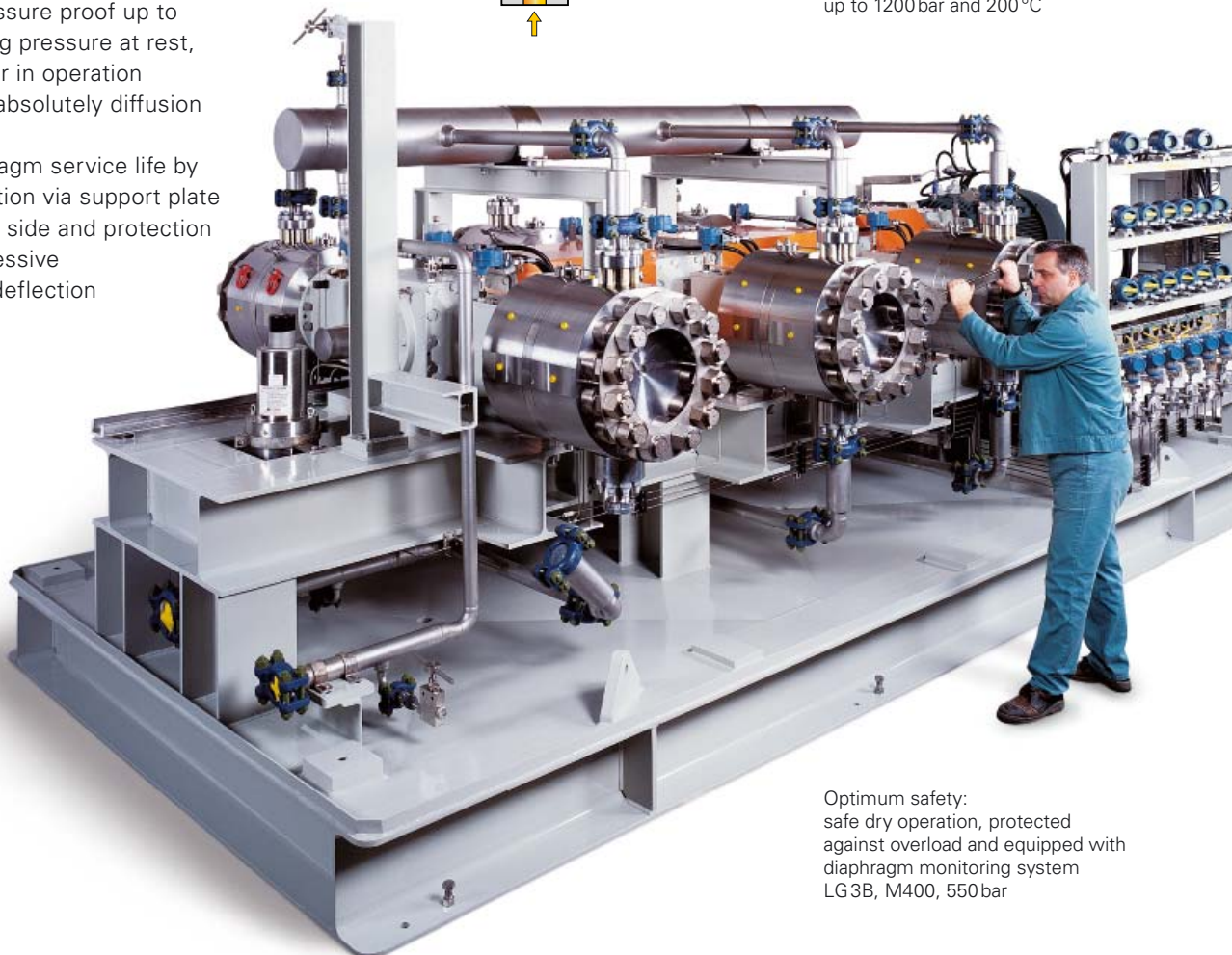

Optimum safety:
safe dry operation, protected
against overload and equipped with
diaphragm monitoring system
LG3B, M400, 550 bar

Partner of the customer: System responsibility from one source



From the pump to the system:
LEWA develops and supplies
solutions for the most different applications

Engineering for pump systems

Apart from specifically adapted process diaphragm pumps LEWA also develops and supplies complete pump systems, which can be easily and directly integrated into the complete installation. All components including control and protection installations are appropriately designed and optimised for the respective application.

Complete service

- Computer-supported, expert design of pipelines and pulsation dampers
- Vibration analysis
- Fluid evaluations
- Commissioning on-site
- System tests
- Service and maintenance contracts
- Service worldwide
- Consultation for changed operating conditions
- Extension and modification of existing pumps and systems

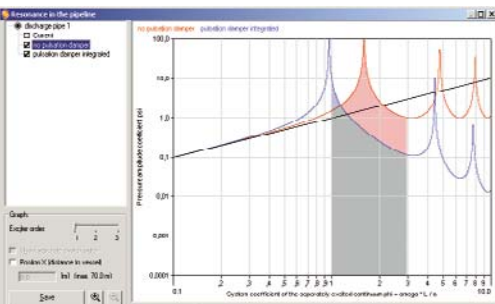

Consultation at an early stage already:
fluid evaluations and computer supported
pipeline calculations save money even
before the actual investment has started

Expandable system solutions

- Instrumentation for the pump
- Flow adjustment via frequency inverter
- Interfaces to the process guiding system
- Online and offline condition monitoring systems for electronic control

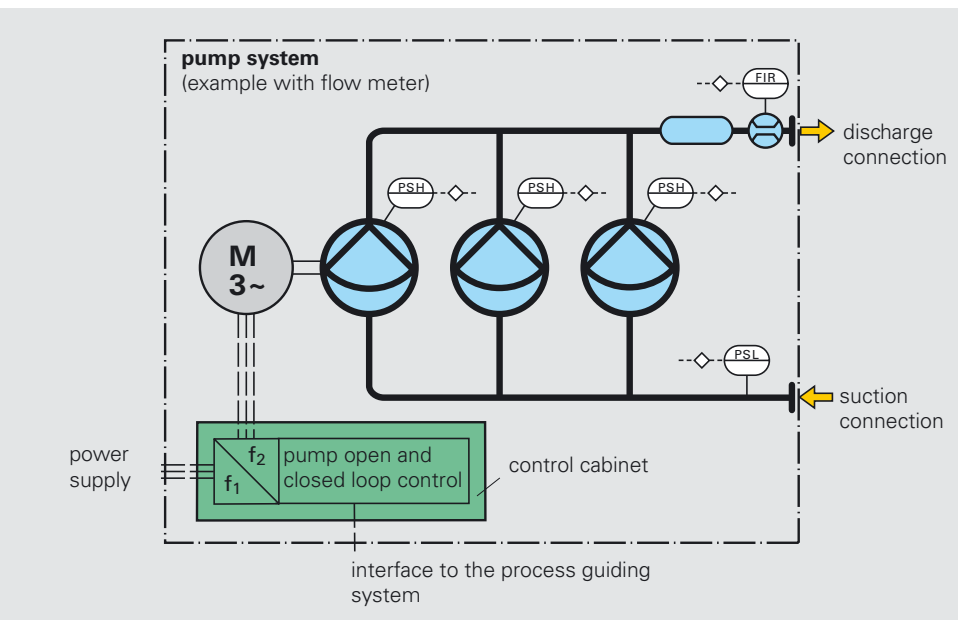
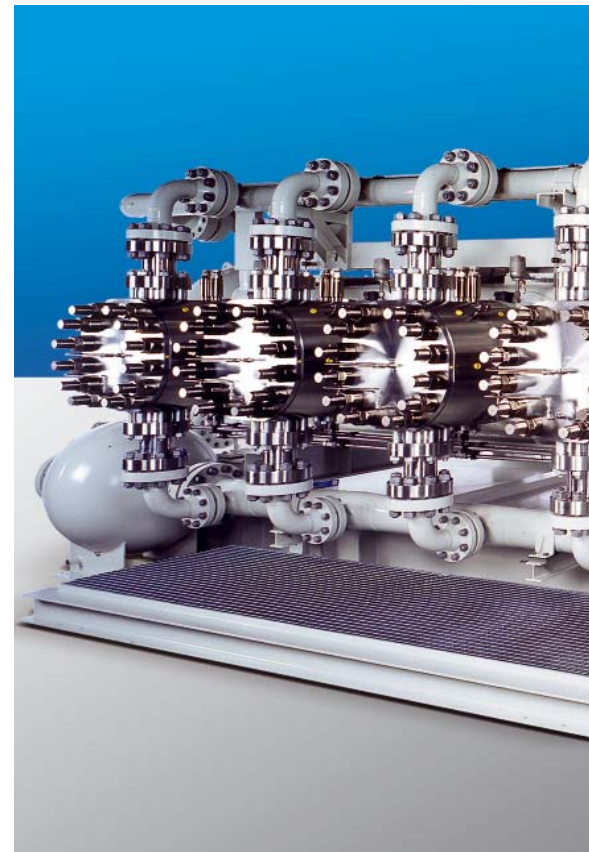

Advantage of diaphragm pumps: Low life cycle costs

Low life cycle costs

The low life cycle costs are determined by a high overall efficiency with low energy costs and by low maintenance costs due to long diaphragm up-times and long maintenance intervals.

The life cycle costs of the LEWA process diaphragm pumps are lower compared to centrifugal pumps.

Reduce life cycle costs with LEWA technology: Excellent results regarding economical efficiency compared to centrifugal or plunger pumps

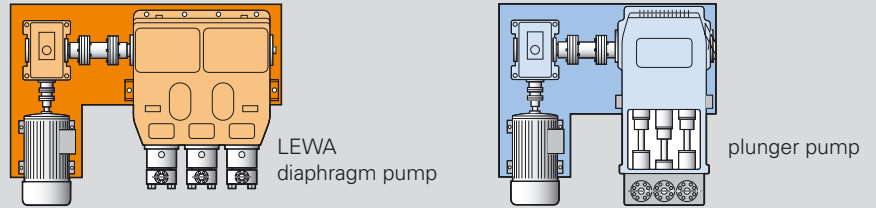

Low energy consumption

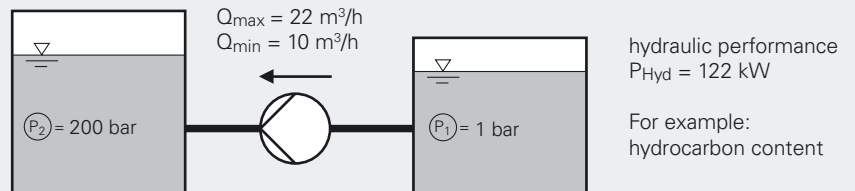

Low life cycle costs

	Centrifugal pump	LEWA diaphragm pump
Relative investment costs	100	175
Efficiency rate	ca. 35%	ca. 85%
Drive power	348 kW	144 kW
Energy costs per year in continuous operation (0,061 EUR/kWh)	186.000,- €	77.000,- €
Costs saved		109.000,- €

Centrifugal pump

Investment costs	Energy costs per year
------------------	-----------------------

LEWA diaphragm pump

Investment costs	Energy costs per year
------------------	-----------------------

Long maintenance intervals: diaphragm pump – plunger pump

Low maintenance costs:

- diaphragm pumps show excellent results regarding economical efficiency compared to plunger pumps

To observe additionally:

- high energy consumption for plunger pumps
- plunger lubricating system for plunger pumps
- leakage draining and handling for plunger pumps

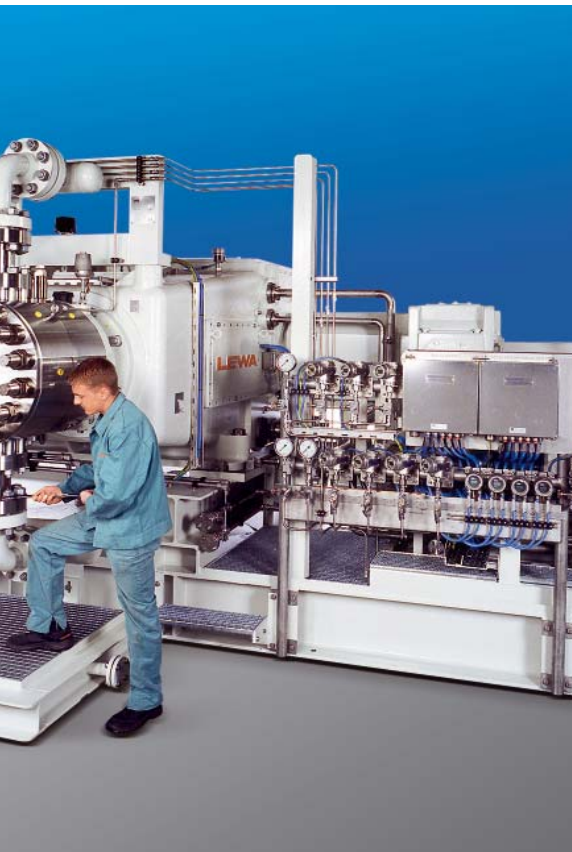
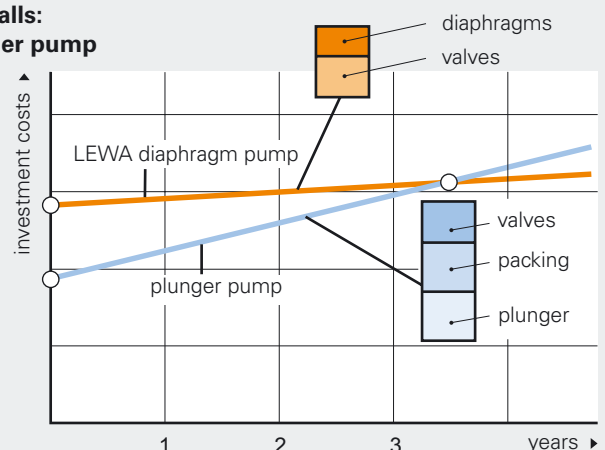

Economical even when pumping critical fluids:
e.g. H₂S/CO₂ compression
G4T, M 514 S, 110 m³/h, 215 bar

Wide application range

Due to their technical features and the very high operational safety LEWA process diaphragm pumps have captured many fields of application.



Example food production:
gentle conveying of food-stuffs,
2x G3S, M500, 6 m³/h at 90 bar



Example chemistry:
highly corrosive intermediate products
14 m³/h, 350 bar, G3R, M500

Technical data

Performance range table

For determining the drive element size. The graphs for the LEWA pump types ES/GS, LDH, LG are applicable for simplex pumps.

Diaphragm pump heads
M400 with metal diaphragm
M500 with PTFE diaphragm
M800 with PTFE diaphragm

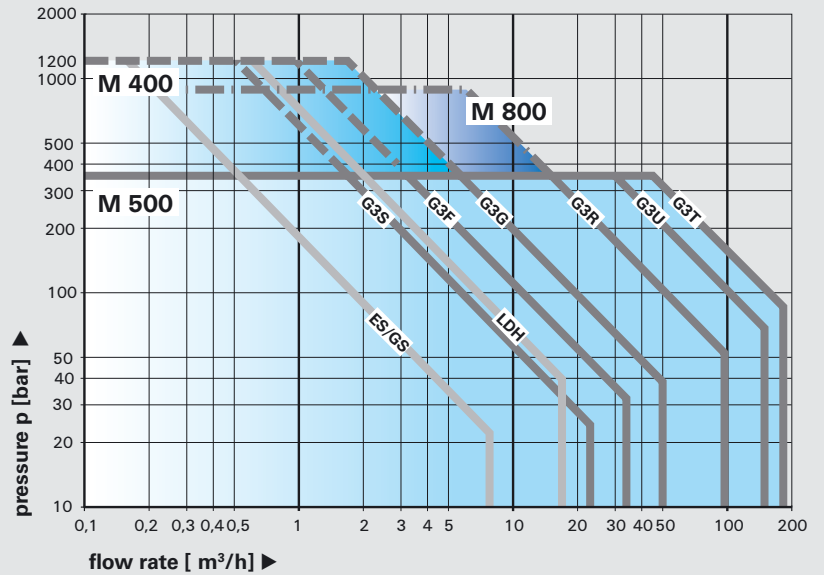

General overall dimensions

Type	L [mm]	B [mm]	H [mm]
G3S	1300	1150	1350
G3F	1600	1550	1850
G3G	2200	1750	1950
G3R	2950	2050	2400

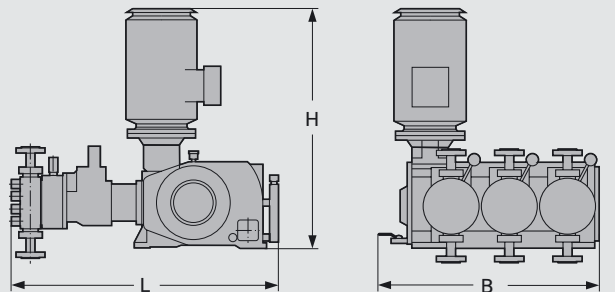

Type	L [mm]	B [mm]	H [mm]
G3U	3300	4450	1750
G3T	3600	4950	2200

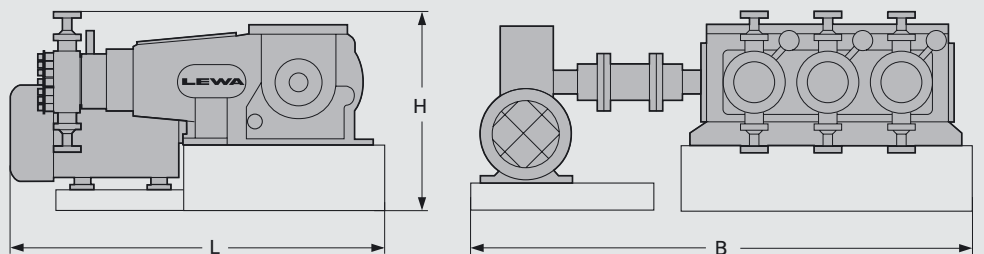

Type	L [mm]	B [mm]	ΔB [mm]	H [mm]
LDE	700	800	320	670
ES/GS	1300	1300	490	1000
LDH/LDHB	2100	1800	717	1500

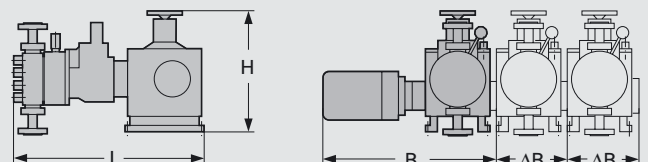

The dimensions given may differ depending on the size and type of pump head mounted

For every occasion: The LEWA product range



LEWA micro-flow metering pumps

For laboratories & pilot plants: LEWA micro-flow pumps

These micro-flow metering pumps with hydraulically actuated metal diaphragms are primarily used in laboratories and for test procedures in pilot plants.

Performance range

Flow rate	up to 0.04 m ³ /h (10.6 USgph)
Discharge pressure	up to 560 bar (8,100 psig)



LEWA ecodos

For low pressures: LEWA ecodos

Standard diaphragm metering pumps for low pressure duty, using a mechanically actuated PTFE quadruple diaphragm for multiple security. Can also be combined as a multiple pump.

Performance range

Flow rate	up to 1.5 m ³ /h (10.6 USgph)
Discharge pressure	up to 560 bar (8,100 psig)



LEWA ecoflow

For medium to high pressures: LEWA ecoflow

LEWA ecoflow offers the most advanced metering diaphragm pumps with leak-free safety for medium and high pressures – not least because of the unique Diaphragm Protection System (DPS).

Performance range

Flow rate	up to 10 m ³ /h per pump head (2,650 USgph)
Discharge pressure	up to 1,200 bar (17,400 psig)



LEWA metering systems
and metering packages

For sterile applications: LEWA Sanitary & Hygienic

LEWA supplies special sanitary and hygienic diaphragm pumps for metering tasks in hygienic, aseptic or sterile procedures, whether for food and beverages or for pharmaceuticals and cosmetics.

Performance range

Flow rate	up to 4.5 m ³ /h per pump head (1,200 USgph)
Discharge pressure	up to 350 bar (5,100 psig)

For closed control loops: LEWA metering systems

LEWA is the first point of contact in the market for high-performance yet economically designed metering systems. These are modular combinations of pumps, valves and controls for stroke lengths and speeds, flow meters (volume or mass flow) and controllers. The metered flow is controlled in a closed control loop.

For process automation: LEWA metering packages

LEWA metering and mixing packages for process automation are available either as standard variants ready for connection, or designed by LEWA specifically for the task on the customer's request. LEWA can supply complete, ready to operate problem solutions. Our services range from engineering through to commissioning – including individual package controls, process visualisation, logging of operational data and external interfaces to the process guiding system.

For more information, please request our individual brochures.

For the highest demands: LEWA engineering & services



Profit from LEWA expertise during the planning stage, the design and during operation

Consultancy & engineering for particular tasks

With over 10,000 successful applications, LEWA has a very wide range of application expertise around the world. Profit from our experience. We see ourselves as a supplier of solutions and systems for any application involving the conveying, metering and mixing of gases and liquids. We can thus provide tailor-made solutions, from the smallest single unit to the largest inline installations, as well as process engineering consultancy for complex tasks. Solutions that meet particular process requirements.

- Fluid assessment
- Installation calculations
- Comparable process engineering applications
- Individually designed concepts
- Commissioning and service
- Seminars and on-site trainings

Global service network for greater availability

LEWA follows its customers around the world. With 16 subsidiaries and numerous authorised agencies, you will find us in all major countries. This local presence is also critical for the successful implementation of international projects. Regular maintenance guarantees the reliability and, particularly, the profitability of a pump system. This is where we can help out with our comprehensive expertise. We look after LEWA installations – worldwide. And we ensure that original spare parts can be supplied and will remain available for many years.



Quickly on site: whether for consultancy, maintenance or servicing, local presence takes top priority at LEWA



For the toughest environments: High levels of reliability even when used under tough conditions

motralec

4 rue Lavoisier . ZA Lavoisier . 95223 HERBLAY CEDEX
Tel. : 01.39.97.65.10 / Fax. : 01.39.97.68.48
Demande de prix / e-mail : service-commercial@motralec.com
www.motralec.com