

Use of Constant Flow Regulators – A contribution to saving energy

Dr. G. Feldle



motralec

4 rue Lavoisier . ZA Lavoisier . 95223 HERBLAY CEDEX
Tel. : 01.39.97.65.10 / Fax. : 01.39.97.68.48
Demande de prix / e-mail : service-commercial@motralec.com
www.motralec.com

Use of Constant Flow Regulators – A contribution to saving energy

Dr. G. Feldle

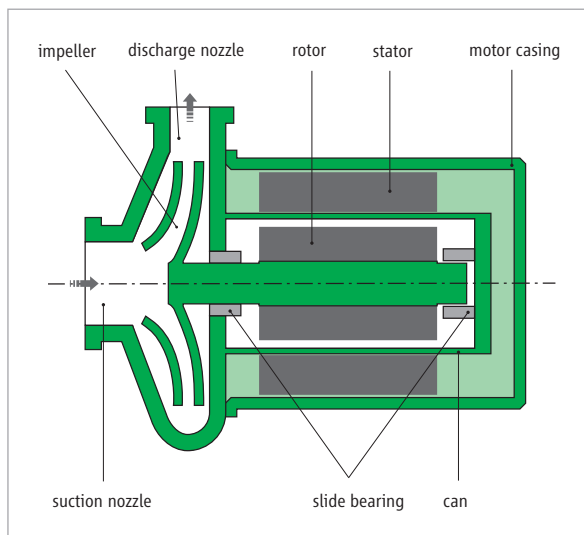

Figure 1: Simplified diagram of a canned motor pump

Increasing environmental awareness has meant that hermetically sealed pumps have become an established technology in the industrial refrigeration industry. This trend has been accelerated partly by legal regulations, and also due to an increased awareness of the total costs of running pumps. The design features of canned motor pumps make them precisely suitable for use in industrial refrigeration applications with liquid gases such as ammonia or freon.

1. PRINCIPLE OF OPERATION

Canned motor pumps are distinguished by a compact, integral aggregate /1/, /2/. The motor and pump form one unit, in which the rotor and the impeller are aligned together on a shaft. The rotor is guided by two identical slide bearings with medium lubrication. The stator of the driving motor is separated from the rotor space by a thin can. Figure 1 shows the schematic structure of a canned motor pump. The rotor space and the hydraulic part of the pump together form a space, which is filled with the pumping medium during operation. The heat lost from the motor is dissipated by a partial flow between the rotor and the stator. The partial flow simultaneously lubricates the two hydrodynamic slide bearings in the rotor space. In addition to the can, which is a hermetically sealed component, the motor casing also provides a second protective covering. This, together with the short compact form and a very low noise level, distinguishes the canned motor pump compared to other sealless pumps. In case of doubt when using dangerous, toxic, explosive, and valuable media, canned motor pumps therefore always offer the best prerequisites.

Use of Constant Flow Regulators –
A contribution to saving energy

Dr. G. Feldle

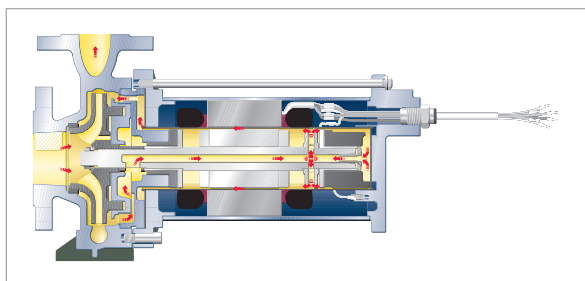

Figure 2: Pump series CNF

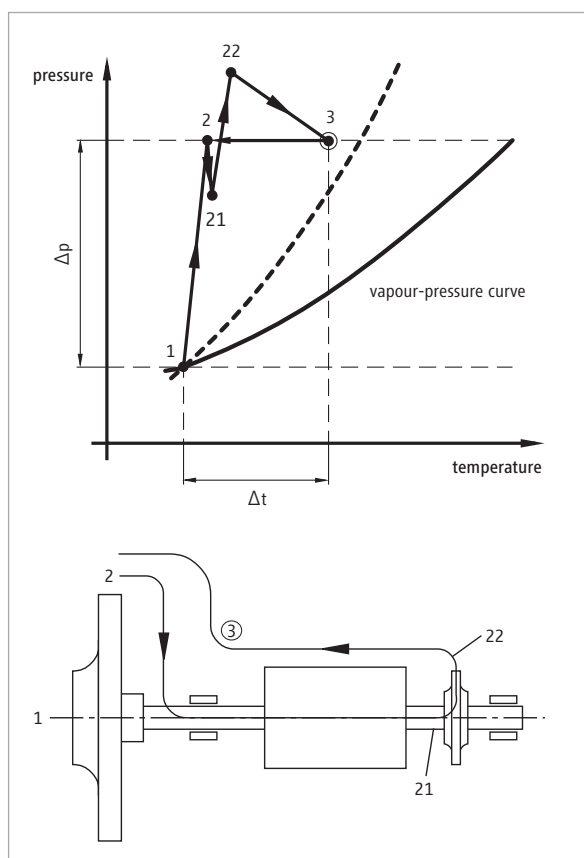

Figure 3: Pressure-Temperature-Diagram showing the return of the partial flow to discharge side

HERMETIC pumps are contained in fully enclosed centrifugal pumps with no shaft seals, which function electromagnetically via the so-called “canned motor”. Depending on the delivery required, single-stage or multistage canned-motor pumps can be used.

Single-Stage Canned Motor Pumps CNF

The CNF range was designed specifically for fluid delivery. [Figure 2] This single-stage pump design can also deliver liquified gases with an extremely steep vapour-pressure curve, without the need for external recirculation of the partial flow into the suction vessel or separator. The partial flow for cooling the motor and lubricating the bearings is separated on the periphery of the impeller via a circular filter, and is guided back to the delivery side after it has flowed through the motor. An auxiliary impeller is used to counteract any hydraulic loss caused by this process. Recirculation to the delivery side means that the greatest heat, which corresponds with point 3 in the pressure-temperature diagram [Figure 3], is at a sufficient distance from the boiling curve. Under otherwise equal conditions, you can therefore use the CNF model to deliver liquified gases with very steep vapour-pressure curves [dashed line in Figure 3].

Multistage Canned Motor Pumps CAM(R)

The CAM [Figure 4] and CAMR [Figure 5] ranges were also developed specifically with industrial refrigeration in mind. Depending on the pump type, unusually favourable NPSH values enable a circulating performance of up to 14 m³/h with a total suction head of only 1.0 m. Pumps can be supplied as 2 to 5 stage aggregates and can be used for both ammonia and freons. The machines have been tested by several classification bodies and approved for use on ships. The CAMR with radial suction nozzles is particularly suitable for „compact“ systems with small collection vessels.



Use of Constant Flow Regulators –
A contribution to saving energy

Dr. G. Feldle

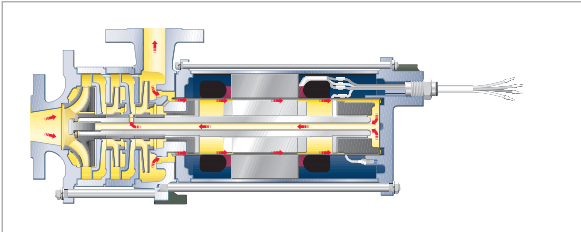

Figure 4: Pump series CAM

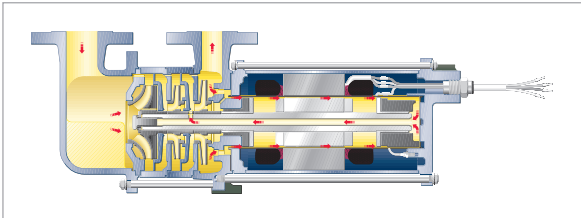

Figure 5: Pump series CAMR

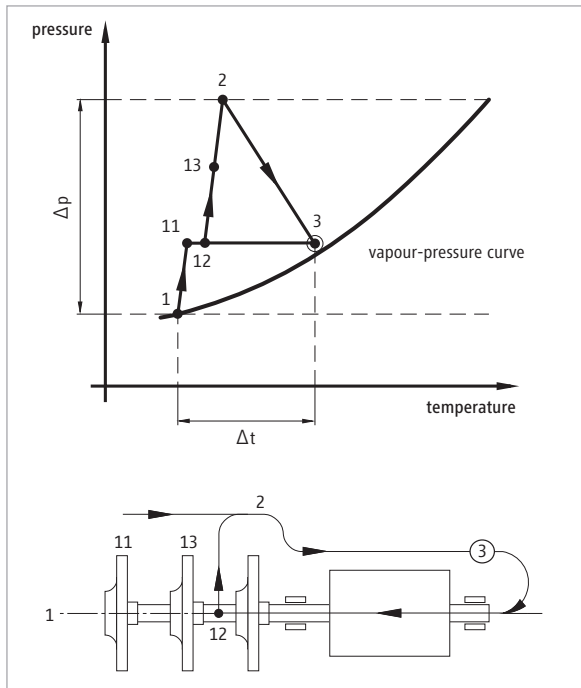

Figure 6: Pressure-Temperature-Diagram showing the return of the partial flow between the stages

The option of degasification on the suction side means that the pump is more quickly returned to a functional state after switching off. To save space, the pump can be suspended directly below the vessel. The partial flow for cooling the motor and lubricating the bearing is extracted after the last impeller on the delivery side and guided through the motor space. It is recirculated through the hollow shaft, not on the suction side of the pump, but rather between 2 impellers in an area of increased pressure. [Figure 6] Point 3 in the pressure-temperature diagram that corresponds to the greatest heat is therefore at sufficient distance from the vapour-pressure curve to exclude the possibility of gasifying within the pump.

2. PROTECTION OF CANNED MOTOR PUMPS

In industrial cooling applications, HERMETIC pumps are usually safeguarded by using orifices. A orifice Q_{min} ensures the minimum throughflow required to dissipate the motor heat loss.

The orifice Q_{max} ensures that the minimum differential pressure required in the rotor chamber to stabilize the axial hydraulic thrust balance and to prevent evaporation of the partial flow is maintained. This orifice also prevents interruption of the flow rate if only a certain minimum total suction head is available.

A constant flow regulator can also be used as an alternative to Q_{max} . The HERMETIC constant flow regulator has been specifically developed for refrigeration systems. These valves ensure safe operation of a pump within a range that is not normally possible for pumps with Q_{max} orifices. Figure 7 shows the additional operating range available when using a constant flow regulator instead of a Q_{max} orifice. This means an increased differential head and higher delivery quantities while still under constant protection against cavitation and motor overload. You can often install a smaller, more



Use of Constant Flow Regulators – A contribution to saving energy

Dr. G. Feldle

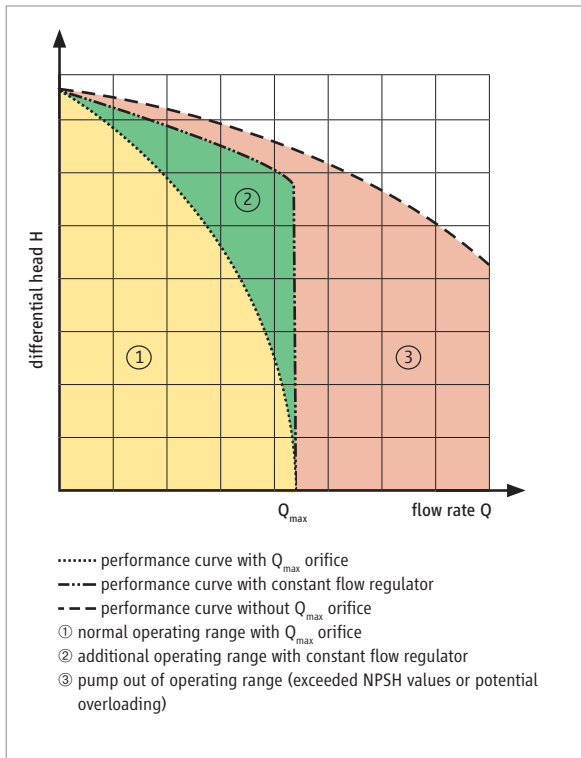

Figure 7: Performance curve with or without Q_{max} protection

cost-effective pump, or for multistage pumps, one level lower. In addition to cost savings through the use of a cheaper pump, the constant flow regulator also offers the advantage of long-term energy savings. The area between the pump characteristic curve with a Q_{max} orifice and constant flow regulator therefore represents the energy saving. The purchasing costs for a pump only represent 5 to 10 % of the lifecycle costs, whereas the energy costs can constitute up to 80 %. This is an additional reason for using the constant flow regulator instead of a Q_{max} orifice [3/, 14/, 15/, 16/.

3. AREA OF APPLICATION

The constant flow regulator is mounted on pump pressure nozzles. The counterflange required for the Q_{max} orifice is therefore not necessary, as it limits the maximum flow rate of the pump. In contrast to the Q_{max} orifice, however, for the delivered quantity $< Q_{max}$ the full delivery pressure of the pump according to the valve is still available. The constant flow regulator controls the flow rate to ensure the maximum delivery quantity is not exceeded. This protects the pump from overloading and keeps the flow rate within the optimal NPSH range of the pump. [Figure 7]

4. MODE OF OPERATION

The limitation of throughflow is achieved through specifically shaped apertures in a spring-loaded movable piston. [Figure 8] The pressure difference before and after the piston causes this to move in such a way that only the relevant amount flows through the apertures. As a consequence, with an increasing difference in pressure, the spring is compressed, which means the specifically shaped apertures are partially exposed. If the pressure difference before and after the valve is reduced, the spring pushes the piston back in accordance with the difference in pressure, and a larger portion of the aperture becomes exposed.

Use of Constant Flow Regulators –
A contribution to saving energy

Dr. G. Feldle

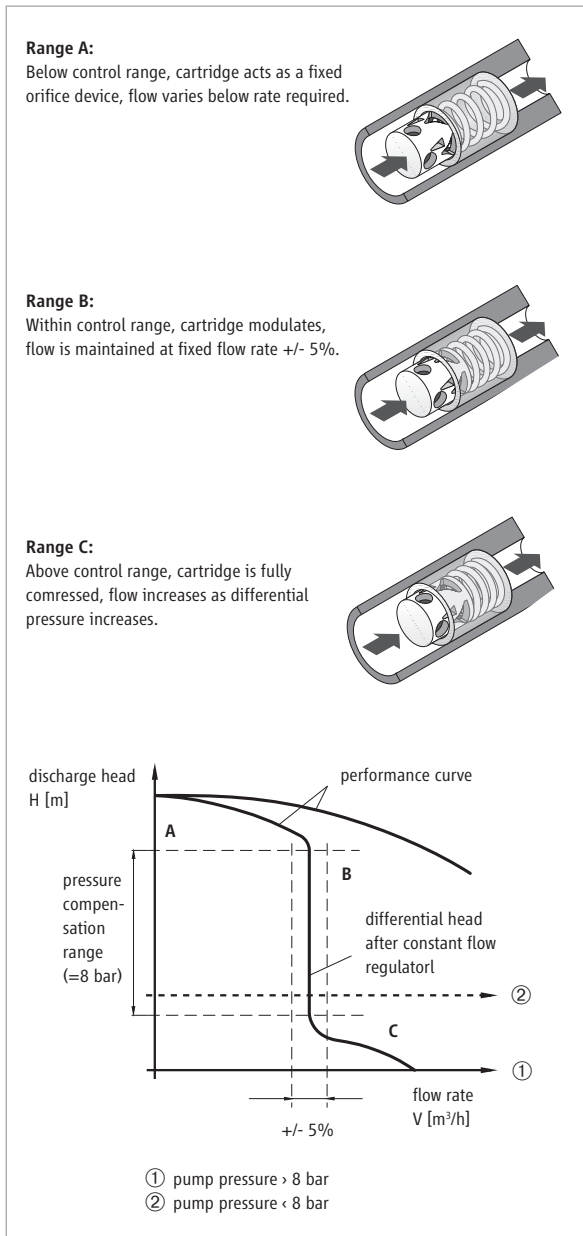

Figure 8: Functional-Diagram of the constant flow regulator

If the pressure difference rises above the determined maximum value (pressure compensation area, generally 8 bar), the spring is compressed to a stop position and the valve then works as a fixed orifice. The same applies if the pressure drops below the required minimum pressure.

5. OPERATION

The constant flow regulator must be filled with fluid during operation. Operation of the valve is dependent on the material properties of the delivery medium. When ordering, it is therefore important to include full details of the characteristics of the pumping medium in the operating range that is to be controlled. The density of the delivery medium is the most important property for correct set-up of the valve.

SUMMARY

The use of HERMETIC pumps compared to conventional, open pumps has become an established technology in industrial refrigeration. The procurement process for centrifugal pumps nowadays must also take lifecycle costs into account. The purchase cost of the pump is only a small fraction of the total costs resulting from a centrifugal pump in the course of its lifetime. The use of constant flow regulators in industrial refrigeration is a contributory factor in lowering the total costs of canned motor pumps.



Use of Constant Flow Regulators –
A contribution to saving energy

Dr. G. Feldle

BIBLIOGRAPHY

- /1/ Krämer, R.
Förderung von Kältemitteln mit hermetischen Kreislumpen
Klima, Kälte, Heizung, Heft 9/85
- /2/ Krämer, R.:
Hermetisch dichte Pumpen mit hoher Verfügbarkeit – eine wirtschaftliche Alternative zu Pumpen mit Gleitringdichtungen
Pumpen + Kompressoren, Vulkan-Verlag, Essen, Heft 2/95
- /3/ Ost, K.
Reduzierung der Lebenszykluskosten von Kreislumpen
Industriepumpen + Kompressoren, Heft 1, März 2001, S. 19 – 22
- /4/ Hennecke, F.W.
Anforderung eines Betreibers – Auswahl und Instandhaltung von Pumpen in chemischen Anlagen
Vortrag Universität Graz, April 2000
- /5/ Krämer, N.
Lebenszykluskostenvergleich zwischen hermetisch dichten Pumpen und konventionellen Kreislumpen auf Gleitringdichtungsbasis
Diplomarbeit Universität Kaiserslautern, Fachbereich Maschinenbau und Verfahrenstechnik, Prof. Hellmann, 1999
- /6/ Hennecke, F.W.
Der Lebenszyklus entscheidet
Process-Magazin für Chemie und Technik, Oktober 1997, S. 68 – 69

motralec

4 rue Lavoisier . ZA Lavoisier . 95223 HERBLAY CEDEX
Tel. : 01.39.97.65.10 / Fax. : 01.39.97.68.48
Demande de prix / e-mail : service-commercial@motralec.com

www.motralec.com

