

Electricity Meters IEC

INDUSTRIAL AND COMMERCIAL

Landis+Gyr Dialog Communication unit

CU-B1 / B2 / B4

TECHNICAL DATA

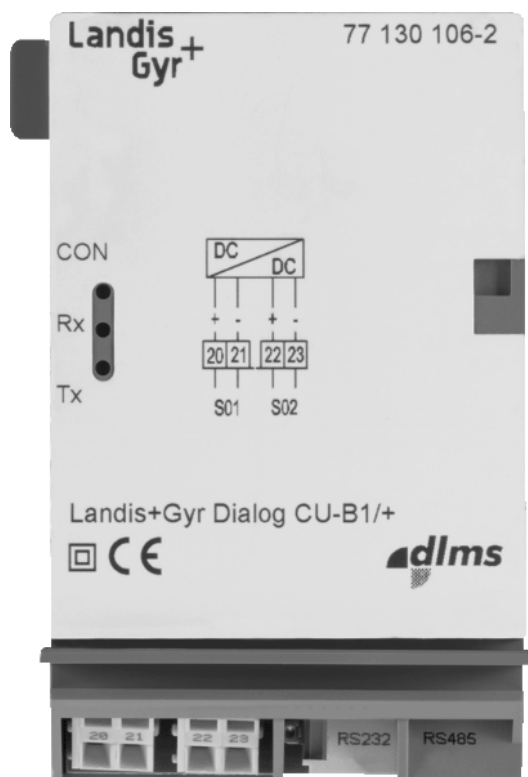

Operating conditions

Standard	IEC61393 / DIN 43864
Rated voltage	24 V DC
Max. voltage	27 V DC
Current	
- Condition "On"	min. 10mA, max 27mA
- Condition "Off"	max. 2 mA
Pulse length	≥30 ms
Max. line length	normally up to 0.5 m
Insulation resistance to meter	4 kV

RS232 interface CU-B1, CU-B4

Asymmetric, serial, asynchronous, bi-directional interface

- 3-wire design basic version
For use with external modems with sufficient intelligence built in
- 6-wire design extended version
For use to initialise the external modem at regular intervals

CU-Bx

Definition and use

Version	S01	S02	RS232	RS485
CU-B1	●	●	●	●
CU-B2				●*
CU-B3	●	●		●*
CU-B4			●	●

* = One RS 485 interface with 2 sockets for rapid and trouble-free wiring

S0-interface CU-B1, CU-B3

The pulse inputs permit the connection of external pulse emitting devices, e.g. electricity-, water-, gas- or heat-meters.

Operating conditions

Standard	DIN 66256
----------	-----------

Pin connections 3-wire basic version

- TxD (Transmitted Data)
- RxD (Received Data)
- GND (Ground)

Pin connections 6-wire extended version

- TxD (Transmitted Data)
- RxD (Received Data)
- GND (Ground)
- CTS (Clear to send)
- DTR (Data terminal ready)
- DSR (Data set ready)

Rated voltage	± 12 V DC
Max. voltage	± 25 V DC

Max. bit rate	56 kbps
Max. line length	up to 15 m
Insulation resistance to meter	4 kV

Additional functions (extended 6-wire version)

- Modem initialisation with AT commands
- Periodic modem initialisation
- Flow control with DTR and CTS
- Time window with multiple-use telephone lines
- Acceptance of calls
- Programmable number of ring signals

RS485 interface CU-B1, CU-B2, CU-B3, CU-B4

asymmetric, serial, asynchronous, bi-directional interface used as communications bus for multiple meter reading applications

Operating conditions

Standard	ISO-8482
Signal condition binary 1	
- Voltage difference	< -0.2 V DC
Signal condition binary 0	
- Voltage difference	> 0.2 V DC
Max. number of slaves	31
Max. line length	depending on environment/cable
- up to 250 m at max. 57'600 bps+max. 31 Slaves	
- up to 550 m at max. 38'400 bps+max. 31 Slaves	
- up to 1000 m at max. 19'200 bps+max. 15 Slaves	
Insulation resistance to meter	4 kV

External influences

In general	same as for base meter
------------	------------------------

Weight and dimensions

weight	ca. 100 g
--------	-----------

Aussenmasse

Width	65 mm
Height	103 mm
Depth	38 mm

Connection to base meter

Base meter to communication unit

via 10-pin plug and socket serving for supply voltage and internal bus and 4-pin plug for ground connection

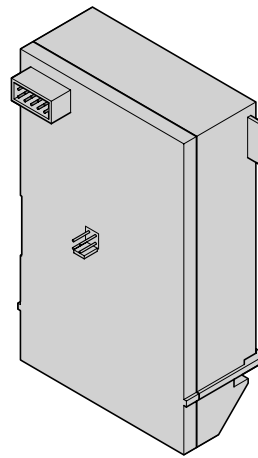

Connection diagram

S0 (pulse inputs)

S01	Pulse input 1
S02	Pulse input 2

RS232 (basic version)

TxD	Transmitted Data
GND	Signal Ground
RxD	Received Data

RS232/+ (extended Version)

CTS	Clear to Send
TxD	Transmitted Data
GND	Signal Ground
DTR	Data Terminal Ready
RxD	Received Data
DSR	Data Set Ready

RS 485

c	Signal ground
a	Data a
b	Data b

CU-B1, CU-B4

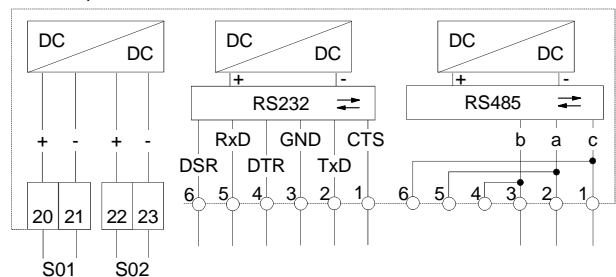

CU-B2, CU-B3

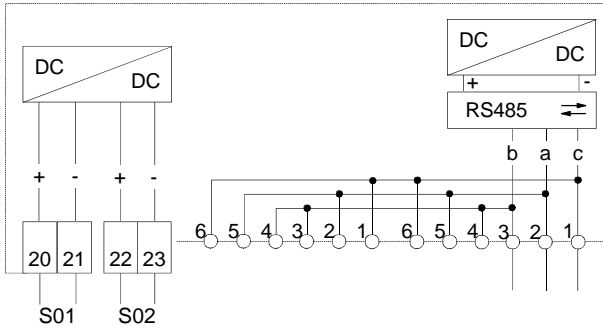

Typical applications

Multiple meter reading (up to 32 meters)

The communication units of the CU-Bx family permit multiple meter reading of up to 32 meters (1 master and up to 31 slaves) via a bi-directional bus that connects the RS485 interfaces of the various meters.

If multiple meter reading of a larger number of meters is required, we are able to propose suitable solutions.

The Landis & Gyr Dialog meter functioning as master uses its RS232 interface for communication with the PSTN modem or the GSM modem. If RS232 interfaces are fitted to the slave meters, these may be used for local applications

Multiple meter reading telephone modem (PSTN)

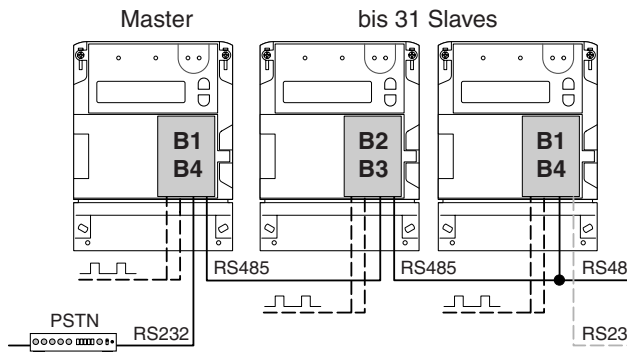

The Landis+Gyr Dialog Meter operating as master uses the RS232 interface for communication with the PSTN-modem.

When using an interface of type RS232/+ it is possible to use a standard modem (transparent modem).

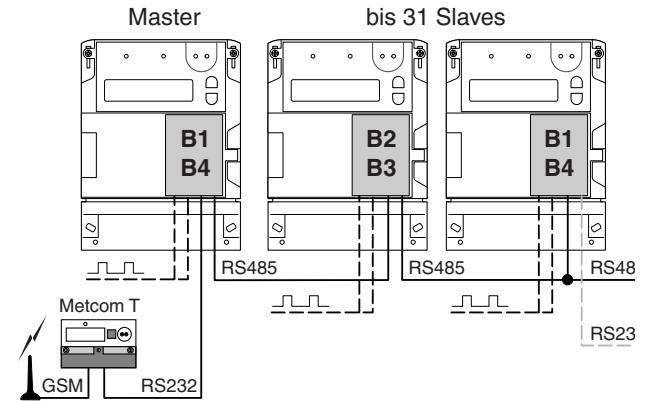

For the same application Landis+Gyr also offers communication modules of type CU-M1 and CU-M4 with built-in PSTN-modem, so that the same application can be achieved without any external devices and cabling between. See respective documentation.

Multiple meter reading by GSM (e.g. MetcomT)

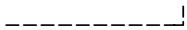
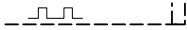

The configuration shown is practically identical to the one shown above, with the difference that instead of a PSTN modem a GSM modem, e.g. MetcomT is used.

Key to symbols used

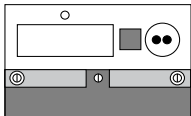
-  Optional data channel for local applications
-  Optional pulse inputs
-  **PSTN-Modem** (Public Service Telefon Network Modem)
-  **MetcomT**
- Product of Landis+Gyr AG
- GSM modem with RS232 or CSinterface

motralec
4 rue Lavoisier . ZA Lavoisier . 95223 HERBLAY CEDEX
Tel. : 01.39.97.65.10 / Fax. : 01.39.97.68.48
Demande de prix / e-mail : service-commercial@motralec.com
www.motralec.com

Landis
| Gyr+

