

Centrifugal pumps according to DIN EN 22858
 Centrifugal pumps according to ANSI B73.3
 Centrifugal pumps for refinery and petrochemical applications according to API 685
 Centrifugal pumps for high pressure
 Centrifugal pumps for high temperature
 Centrifugal pumps containing
 Centrifugal pumps for mining
 Multistage centrifugal pumps barrel-type
 Wide channel centrifugal pumps
 Sewer pumps
 Emerged centrifugal pumps
 Suction centrifugal pumps

Centrifugal pumps, according to DIN EN 22858
 Multistage pumps, according to DIN EN 22858
 Construction and vertical propeller pumps
 Large propeller pumps
 Large centrifugal pumps
 Self-suction chemical pumps

Application range:

Valves:

- ▶ Valves, Taps
- ▶ Valves
- ▶ Gate valves

Strainers
 Filters
 Bottom valves

motralec . 4 rue Lavoisier . ZA Lavoisier . 95223 HERBLAY CEDEX. Tel. : 01.39.97.65.10 / Fax. : 01.39.97.68.48
 Demande de prix / e-mail : service-commercial@motralec.com . Site Internet : www.motralec.com



**CENTRIFUGAL PUMP TYPE
 SLM NV TO DIN EN 22858
 AND DIN EN ISO 15783**
 SEALLESS WITH MAGNET DRIVE



Safety and environmental protection

SLM NV – More than just a standard pump

This pump, to DIN EN 22858, is very much more than just a standard pump. It is the current further development in our well-proven series of sealless magnet drive centrifugal pumps. With the SLM NV, Klaus Union has developed a pump design to address today's industry requirements and to offer new efficient and demand-driven solutions. Requirements have increased, become more complex, and more specific in recent years, particularly in the chemical and petrochemical industry where pumps handle aggressive, toxic and explosive liquids under highest safety requirements.

Klaus Union satisfies these requirements with over fifty years of experience in development, construction, manufacturing and in the application of magnet drive pumps.

SLM NV - "V" stands for "variable" through modular design. Features and benefits of the modular "V-Concept" are:

- ▶ Few individual components – multifunctional, individual application
- ▶ Greater safety over the entire construction range
- ▶ Suitable for serial fabrication at competitive prices
- ▶ Standard modules offer many design variations
- ▶ Energy efficient systems
- ▶ Maximum flexibility and interchangeability
- ▶ Off-the-shelf availability of parts, components and accessories

The construction series SLM NV covers the complete performance range of single-stage centrifugal pumps. Pumps for high system pressure applications are available upon request.



Quality assurance

A major component of our Company ethos is to ensure the highest quality of our products. Existing quality assurance procedures with our suppliers are constantly monitored from order placement, goods inward through to final assembly. This quality assurance system, developed on modern principles, complies with the requirements of international regulations. Klaus Union is a DIN EN ISO 9001:2000 certified Company and is certified accordingly.

Performance range

Flow rate: Q = up to 3.500 m³/h
Delivery head: H = up to 200 m L. C.
Higher flow rates upon request

Pressure ratings/temperature ranges

Standard construction: PN 16 at 120 °C
Temperature range: -120 °C up to +350 °C,
upon request up to
max. +450 °C
Pressure rating: up to PN 400
Higher pressure ratings upon request



Constructional details SLM NV

Basic design to DIN EN 22858

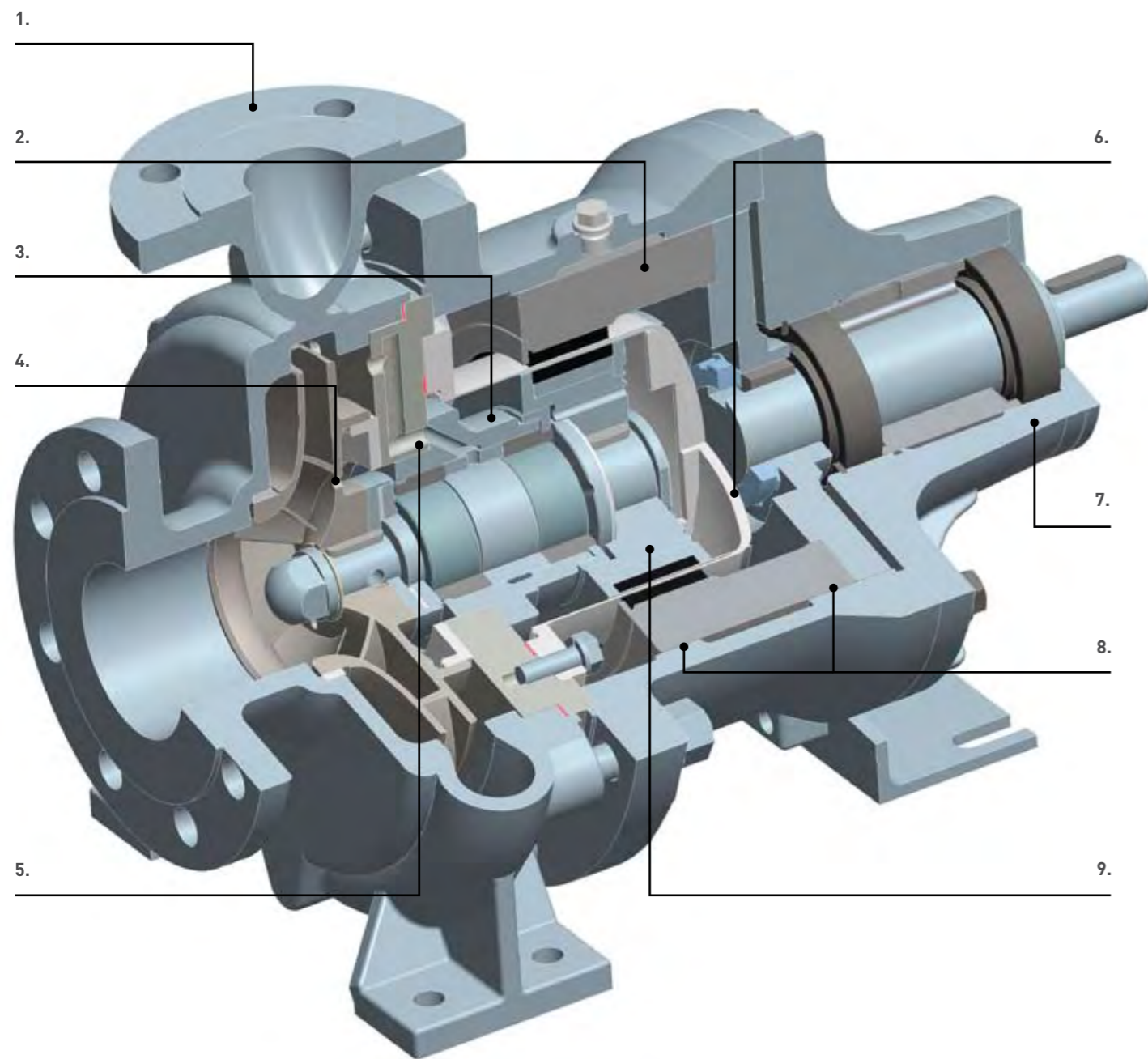

1. Pump casing
PN 16 at 120 °C

2. Outer magnet carrier
Two piece with rub ring on the intermediate lantern

3. Journal bearings
Double bearing made of SSiC;
Counter centred combination for universal utilisation over a wide temperature range

4. Balancing holes
Optimized thrust loads over the entire operating range via hydraulic measures

5. Flushing system
Pressurised to safely handle liquids close to boiling point

6. Isolation shell
Self-venting and fully drainable;
Vortex breaker

7. Bearing support
Grease-lubricated anti-friction bearings

8. Intermediate lantern
With outer magnet carrier rub ring and assembly/disassembly guidance

9. Inner magnet carrier
With rub ring on the journal bearing bush

SLM NV – The modular system that makes everything possible

Modular System

The modular system allows combining suitable modules to meet the particular requirements of your specific application. The following illustrations show a few examples – but only some out of the many variations available.

Talk to us about your specific application. We will show you how “your” pump might look.

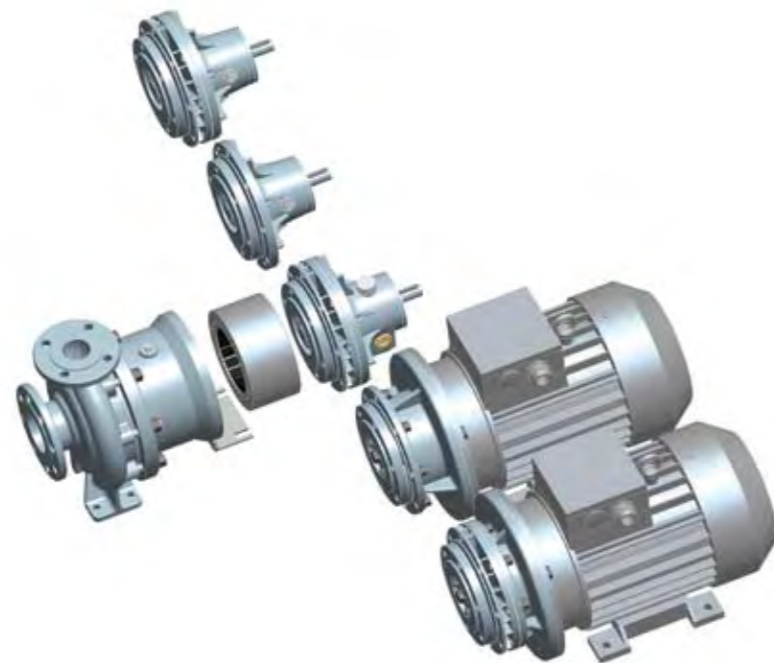

The variable modular system allows any combination of modules to meet the individual requirements of your application.

Any combination is possible!

Options

SLM NVS ... ZL

- ▶ Grease-lubricated anti-friction bearings with increased bearing spacing
- ▶ Non-metallic isolation shell “Z” (zirconium oxide)
- ▶ Secondary sealing between the anti-friction bearings “L”

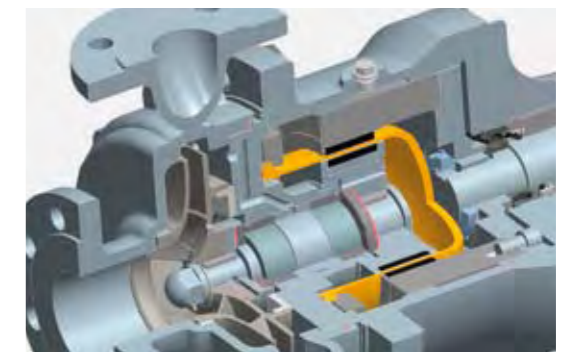

SLM NVS ... E1F

- ▶ Grease-lubricated anti-friction bearings with increased bearing spacing
- ▶ External recirculation via discharge filter “E1F”

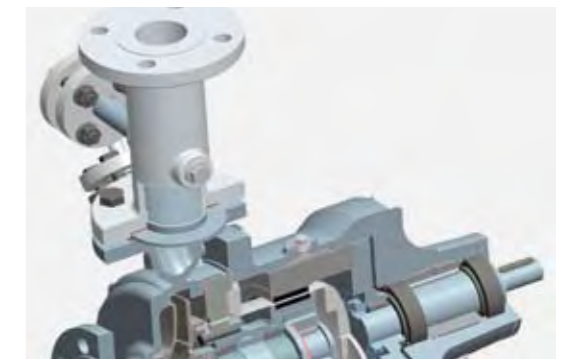

Construction types

“Z” Isolation shell made of zirconium oxide

This isolation shell generates no Eddy Current losses in the magnet drive. This isolation shell offers maximum pump efficiency and is particularly beneficial where heat input into the pumped liquid is to be avoided.

“L” Secondary sealing between the anti-friction bearings

The secondary sealing consists of a high-performance radial shaft seal ring, which ensures that there is no immediate leakage of

the liquid to the atmosphere in the drive shaft area in the event of an isolation shell failure.

“E1F” External recirculation via discharge filter

The self-cleaning discharge filter is used for applications where liquids with a moderate percentage of solids are handled. The flush flow is picked up externally from the discharge filter and re-introduced into the magnet coupling. The internal flush flow ports are closed.

Options for every requirement



SLM NVO ... H12F

- ▶ Oil-lubricated anti-friction bearings with thermal barrier and secondary sealing
- ▶ Jacketed hydraulic casing "H1"
- ▶ Jacketed intermediate lantern "H2"
- ▶ Internal filter "F"

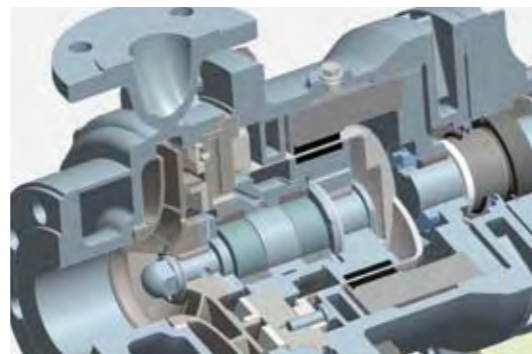

SLM NVO ... C

- ▶ Oil-lubricated anti-friction bearings with thermal barrier and secondary sealing
- ▶ Plastic isolation shell CFRP/PTFE "C"

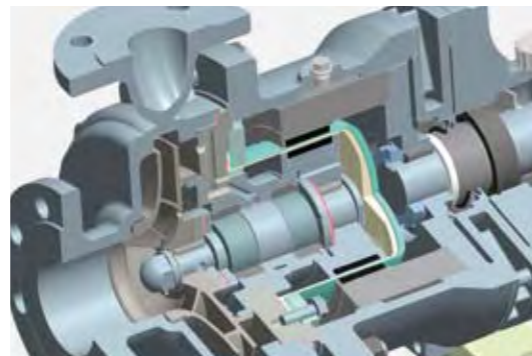

Construction types

"H1" Jacketed hydraulic casing for heating

"H2" Jacketed intermediate lantern for heating

The heating jacket serves to heat the pump prior to starting or to maintain temperature.

"F" Internal filter

The self-cleaning internal filter is used for handling liquids with a low percentage of solids. The filter sits in front of the flush flow channel's entry ports. It ensures that no solid matter that could damage the magnet drive or the journal bearing can enter the flush flow circuit.

"C" Plastic isolation shell

The plastic isolation shell consists of two separate components – a carbon fibre reinforced outer shell, and an inner PTFE liner. The shell eliminates Eddy Current losses and is used to maximise the pump's over-all efficiency, or when a temperature rise of the internal flush flow must be avoided.

SLM NVB ... WJ

- ▶ Close-coupled construction
- ▶ Thermal barrier with secondary sealing "W"
- ▶ Inducer "J"

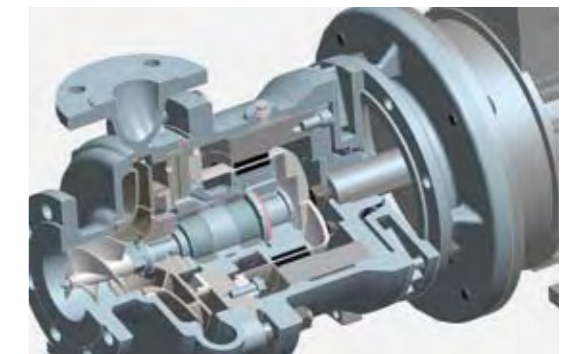

SLM NVB ... OTZW

- ▶ Close-coupled construction
- ▶ Construction without flush flow "OT"
- ▶ Non-metallic isolation shell "Z" (zirconium oxide)
- ▶ Thermal barrier with secondary sealing "W"

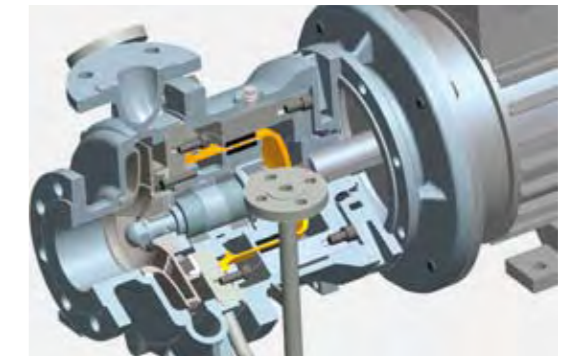

Construction types

"W" Thermal barrier with secondary sealing

The thermal barrier reduces heat transfer from the pump end to the anti-friction bearings. By using the thermal barrier, the temperature at the anti-friction bearings is reduced by 20°C to 30°C. A high-performance radial shaft seal ring is integrated in the thermal barrier as a secondary sealing. The gasket prevents immediate liquid leakage in the event of isolation shell failure.

"J" Inducer

The inducer is fitted in front of the impeller and increases the suction pressure. It offers enhanced NPSH characteristics to the pump

and can often almost half the NPSH requirements.

"OT" Construction without flush flow

This construction type is used for applications where liquids with a high percentage of solids are handled. The casing cover is equipped with two external connections for feeding and draining of the isolation shell area. The specially designed journal bearings prevent any solids within the pumped liquid from entering the magnet drive.



Performance curves SLM NV

Performance curve 50Hz

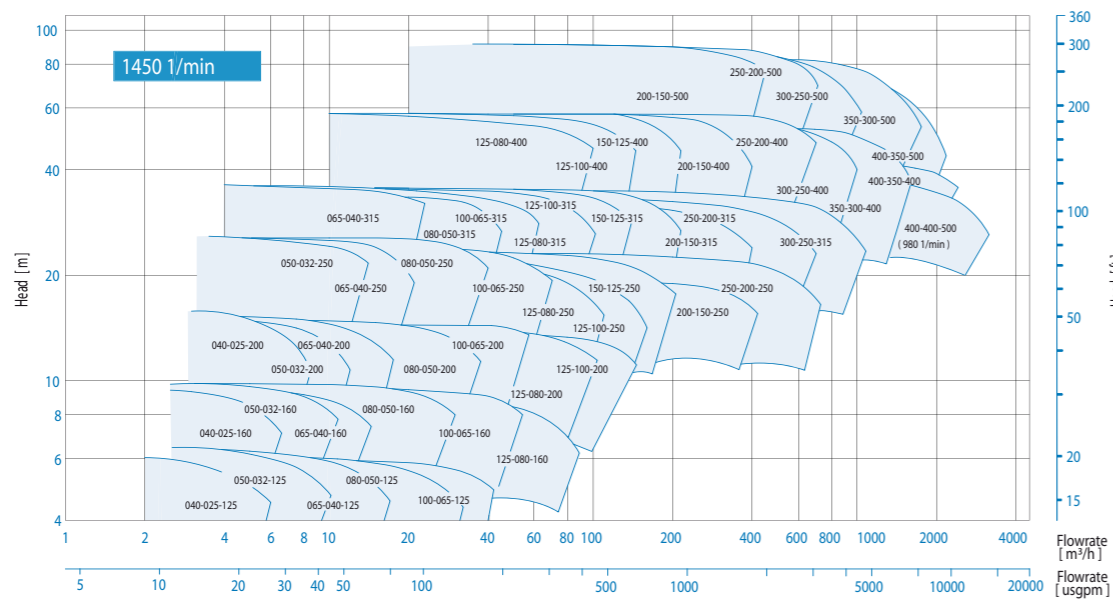

Performance curve 60Hz

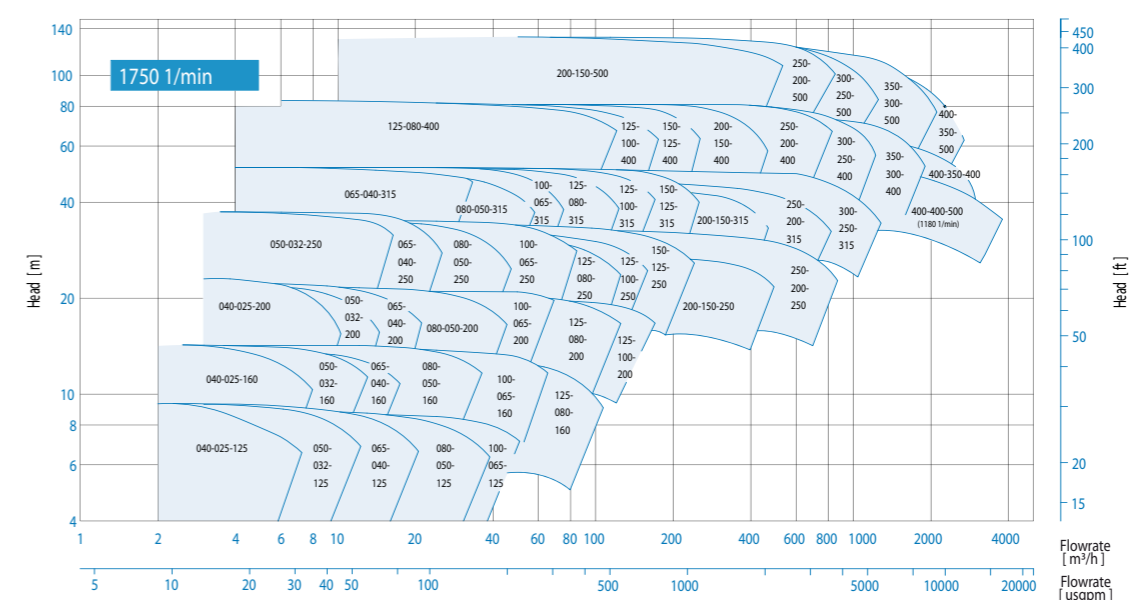

Performance curve 50Hz

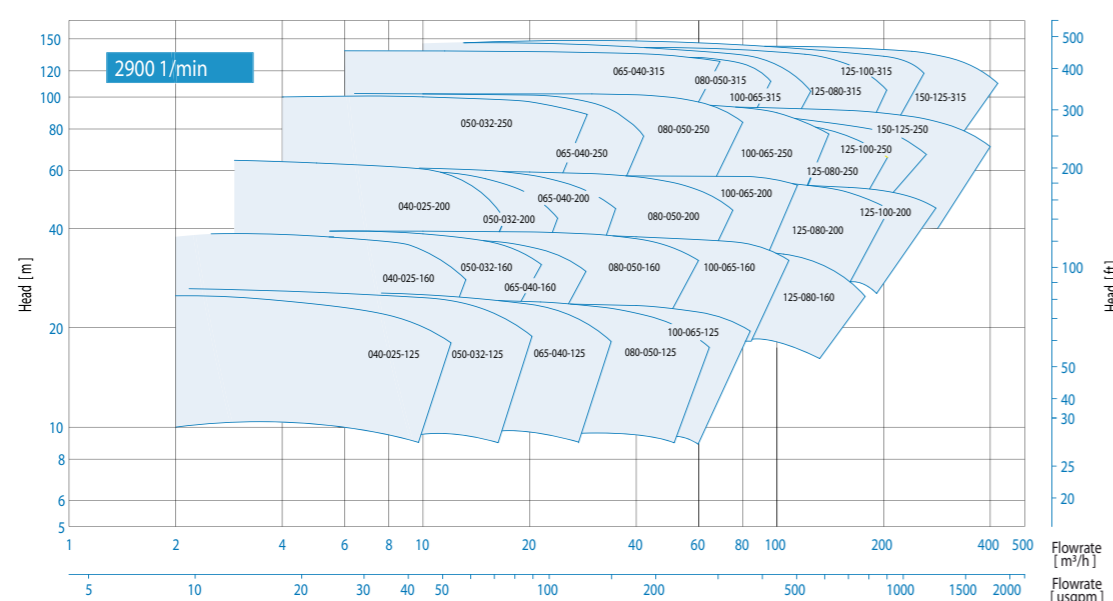

Performance curve 60Hz

