

**Production range pumps:**

**Pumps with magnet drive**

- ▶ Chemical centrifugal pumps according to API 685
- ▶ Centrifugal pumps according to API 685
- ▶ Centrifugal pumps for refinery and petrochemical applications
- ▶ Centrifugal pumps for high pressure applications
- ▶ Centrifugal pumps for high temperature applications
- ▶ Centrifugal pumps for liquid containing solids
- ▶ Self-priming pumps, self-priming pumps
- ▶ Self-priming pumps, self-priming pumps
- ▶ Submersible centrifugal pumps
- ▶ Double suction centrifugal pumps

**Pumps with shaft sealing**

- ▶ Centrifugal pumps according to API 685
- ▶ Multistage pumps
- ▶ Horizontal and vertical propeller pumps
- ▶ Bottom-flange pumps
- ▶ Submersible pumps
- ▶ Double suction pumps

**Production agitators**

- ▶ Agitator drives with magnet

**Production range valves:**

- ▶ Gate valves, wedge gate valves
- ▶ Gate valves, isomorphous construction series
- ▶ Gate valves, wedge orifice valves
- ▶ Relief valves
- ▶ Check valves
- ▶ Sight glasses
- ▶ Strainers



**Klaus Union**  
15410 Lillja Rd  
Houston, TX 77060

Phone 281-999-1182  
Fax 281-999-1185  
E-Mail [info@klausunion.com](mailto:info@klausunion.com)  
Internet [www.klausunion.com](http://www.klausunion.com)

**motralec** . 4 rue Lavoisier . ZA Lavoisier . 95223 HERBLAY CEDEX. Tel. : 01.39.97.65.10 / Fax. : 01.39.97.68.48  
Demande de prix / e-mail : [service-commercial@motralec.com](mailto:service-commercial@motralec.com) . Site Internet : [www.motralec.com](http://www.motralec.com)

**PUMP TYPE SERIES SLM AVP  
ACCORDING TO API 685**

PRODUCT CATALOGUE



# Safety and environmental protection

## Pump type series SLM AVP according to API 685

This pump for refineries and the petrochemical industry is the consistent further development of the proven Klaus Union centrifugal pumps with magnet drive and without shaft seal.

The Klaus Union pump type series SLM AVP fulfils the high technical and economic demands that refineries and the petrochemical industry impose today on pumps without shaft seals.

From a safety-engineering point of view, the SLM AVP is an enhancement of the pumps with mechanical seal formerly utilised, which are described in the API 610 standard.

The construction type without shaft seal but with magnet drive guarantees that the pump is absolutely leak free, in accordance with the TA-Luft specification (German Technical Instruction on Air Quality Control), and maintenance-free in operation, compared to the version with mechanical seal.

The construction series SLM AVP covers the complete performance range of single-stage centrifugal pumps. Multistage pumps and pumps constructed for high pressure operation are also available as special designs.



## Quality assurance

Since 1989, Klaus Union implemented a certified quality assurance system according to DIN EN ISO 9001: 2000.

## Performance range

Flow rate: Q = up to 3,500 m<sup>3</sup>/h  
 Delivery head: H = up to 200 m L.C.  
 Higher capacities upon request

## Pressure ratings

Flanges according to ANSI/ ASME B16.5, Class 300 (PN50)  
 Temperature: -120°C up to a maximum of +450°C  
 Other pressure ratings upon request

## Materials as in the standard (API-685 Appendix H)

Components	A-8	S-8
Pump casing	316 Austenite	Carbon steel
Impeller	316 Austenite	316 Austenite / Carbon steel
Isolation shell	Hastelloy C	Hastelloy C
Pump shaft	316 Austenite	316 Austenite / Carbon steel
Intermediate lantern / bearing support	Cast steel	Carbon steel
Drive shaft	Carbon steel	Carbon steel

Other materials upon request



# Constructional details of SLM AVP

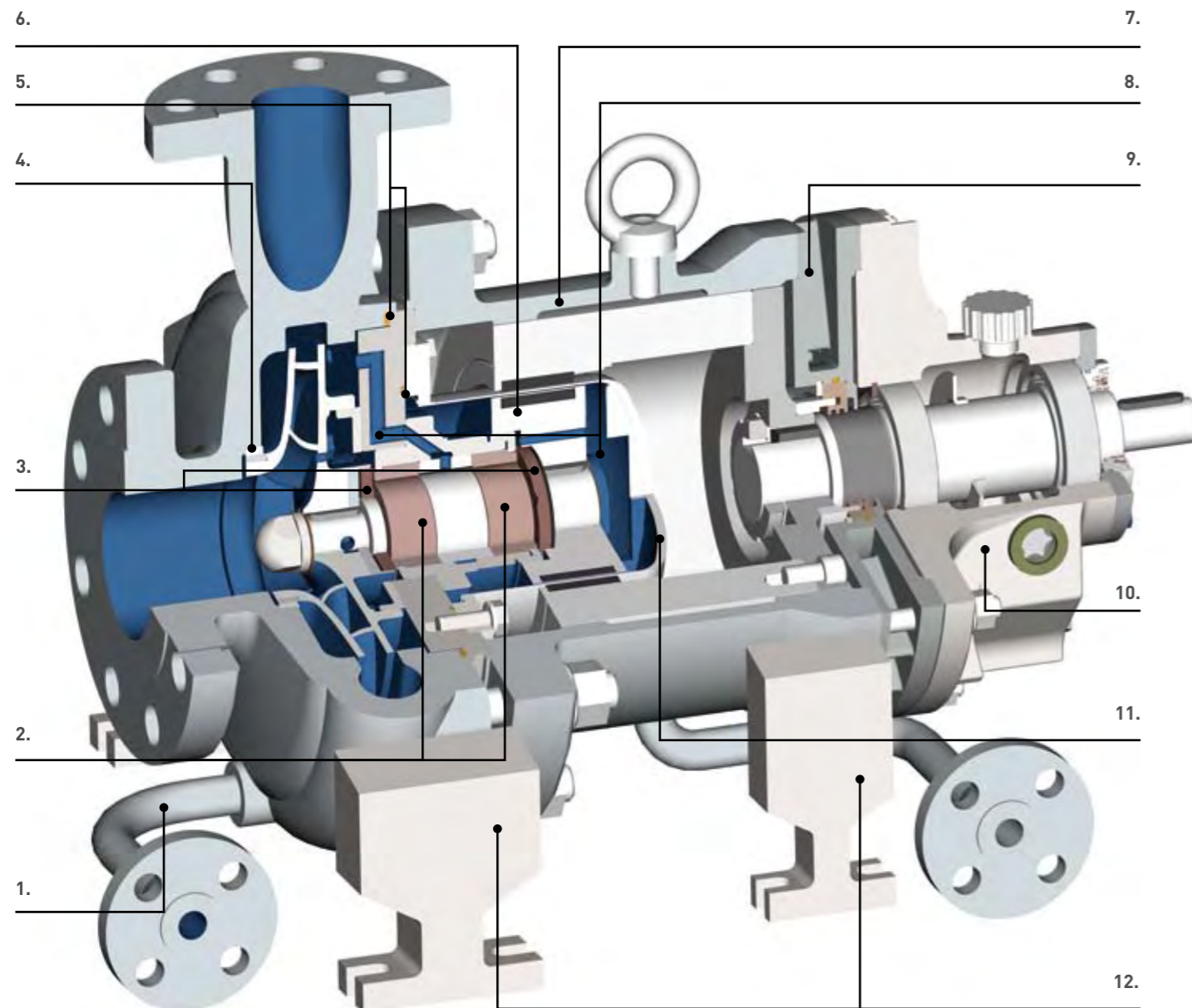

**1. Casing drain (API-§ 6.4.3)**  
With flange

**2. Journal bearing (API-§ 6.10)**  
Double bearing made of silicon carbide (SSiC);  
counter centred combination for universal utilisation.

**3. Thrust bearing (API-§ 6.10)**  
Hydraulic measures reduce axial thrust over the  
complete performance range

**4. Wear rings (API-§ 6.7)**  
Replaceable on the impeller and in the casing

**5. Gasket (API-§ 6.3.5)**  
On the isolation shell placed in shunt

**6. Inner magnet carrier (API-§ 9.1.3.3)**  
With additional mechanical rub ring

**7. Intermediate lantern (API-§ 9.1.3.3/9.1.3.5)**  
With magnet drive rub ring and assembly/  
disassembly guidance

**8. Flushing system (API-§ 6.1.6)**  
Pressurised over the entire operating range

**9. Thermal barrier**  
Lowers the anti-friction bearing temperature and  
thus increases the working life of the anti-friction bearings.

**10. Bearing support (API-§ 9.1.4)**  
Oil lubrication with labyrinth sealing

**11. Secondary sealing (API-§ 3.66/3.64)**  
Single isolation shell with leakage monitoring and drain  
(secondary control system)  
**Optional:** Double isolation shell with pressure monitoring  
(secondary containment system)

**12. Casing and intermediate lantern (API-§ 6.3.8)**  
Centreline support

# The highest level of operational reliability throughout the process

## Pump casing

The design of pump casing has been calculated with the help of the finite element method (FEM) for 50 bar maximum internal pressure at 120°C and a nozzle load corresponding to double the values specified in API 685. The corrosion allowance of 3 mm stipulated according to § 6.3.3 has been taken into consideration. The flange connections are designed according to ANSI/ASME B16.5, Class 300.

Von Mises tension (maximum)  
Averaged values  
Original models  
Combination  
Principal units  
(mmNs)

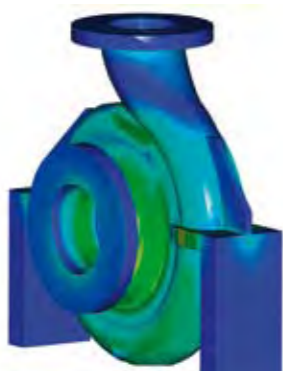
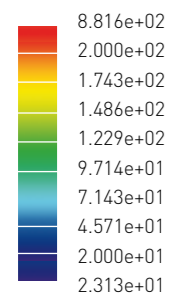
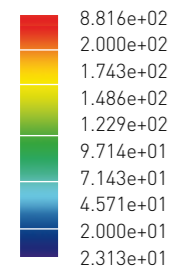

## Journal bearings (API-§ 6.10)

The thrust and radial journal bearings are self-lubricated and in the standard design consists of pure sintered silicon carbide (SSiC). The journal bearing components are fixed and secured in both the axial and radial directions. Compensation for the different thermal expansion coefficients of the metallic and ceramic components is ensured by the constructional design.

The pressurised flush flow for lubrication and cooling of the journal bearings is taken from a high pressure location in the hydraulic system and fed directly into the journal bearings (see Fig. 1).

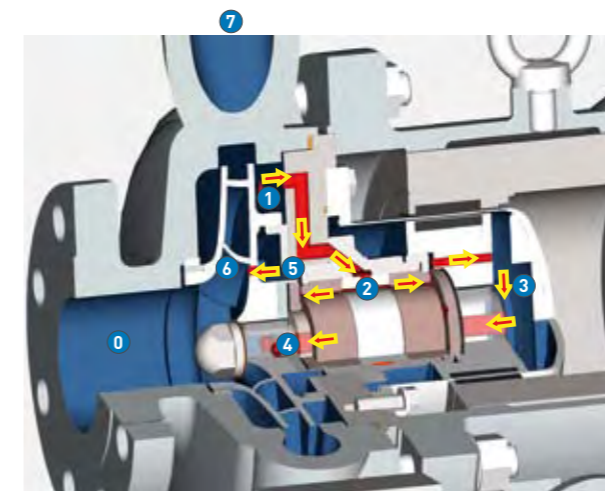
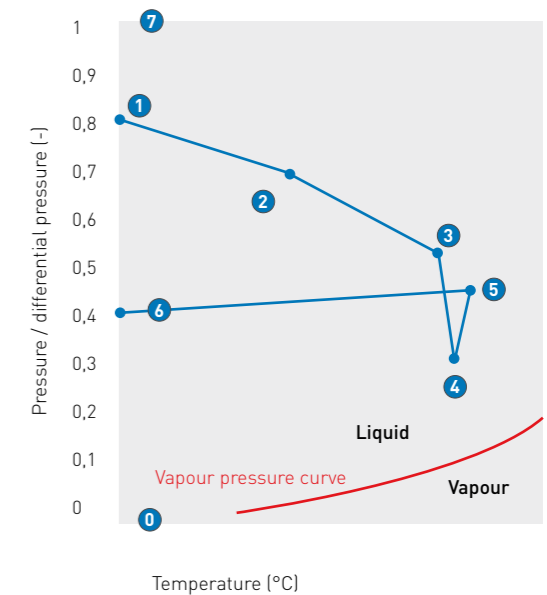

Fig.1. Pressure / temperature profile / journal bearing flush flow



## Magnet drive (API-§ 9.1.3/6.1.6)

The magnet drive is configured concentrically and transmits torque without slip via the field of the permanent magnets. The thermally stable samarium-cobalt (Sm2Co17) withstands operating temperatures of up to 400°C. The magnetic material aluminium-nickel-cobalt (AlNiCo) is utilised for higher temperatures of up to 450°C.

A second pressurised flush flow is taken off at a high pressure location in the hydraulic system and fed to the magnet drive, where it provides for the necessary heat dissipation. The pressurised flush flow ensures that the temperature rise in the isolation shell area does not lead to evaporation of the pumped liquid (see Fig. 2).

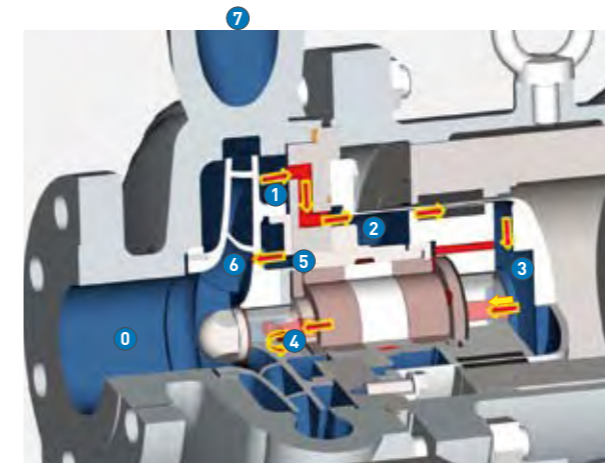
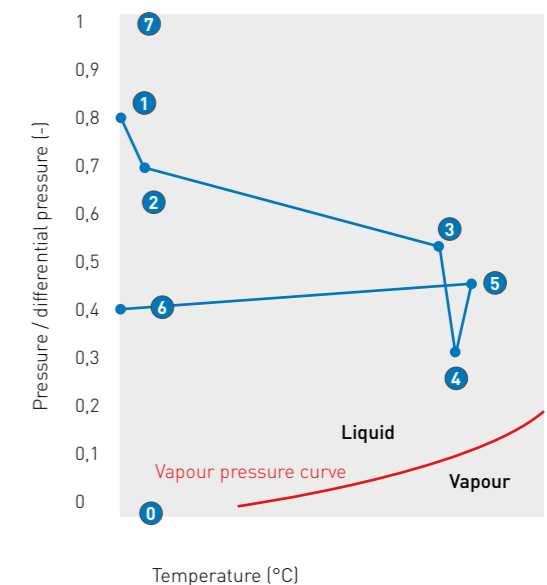

Fig.2. Pressure / temperature profile / isolation shell flush flow



# Protection and safety are of primary importance



## **Klaus Union-Standard: Single isolation shell with leakage monitoring and drain at the intermediate lantern. (API-§ 3.66)**

The standard version of the SLM AVP pump is equipped with a single isolation shell. The intermediate lantern is equipped with a labyrinth system to the atmosphere, a leakage monitoring system and a drain connection. A pressure gauge or a liquid sensor can be utilised as a leakage monitor. The labyrinth seal upstream of the anti-friction bearings serves as a throttling point in the event of isolation shell damage leading to product escaping into the intermediate lantern. The pressure rise or the presence of liquid is detected by the monitoring system. This design corresponds to the secondary control system described in API 685 (§ 3.66).

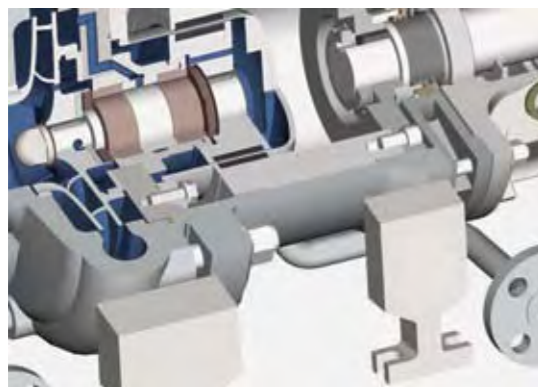

Drive unit with secondary control system

## **Optional: Double isolation shell with pressure monitoring. (API-§ 3.64)**

In this version, the pressure-containing second (outer) isolation shell serves as secondary containment and thus fulfils the API definition of the secondary containment system according to § 3.64.

The outer isolation shell is arranged concentrically around the inner isolation shell. The pressure is monitored in the cavity between the two containment shells and is configured with a pressure below atmosphere in the state of the pump as delivered. It is thus possible to detect isolation shell damage from outside and from inside. In the event of damage from outside, the pressure monitor will indicate atmospheric pressure; whereas in the event of damage from inside, the system pressure will be indicated.

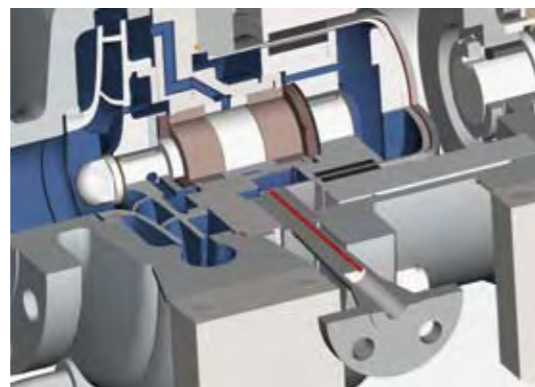

Double isolation shell as secondary containment system

## **Outer magnet carrier protection (API-§ 9.1.3.5) and rubring zones (API-§ 9.1.3.3)**

To protect the isolation shell, rubring zones are provided on both the outer magnet carrier and the inner magnet carrier. In the event of a deflection of the magnet rotors, this effectively avoids contact of the rotors with the isolation shell to avoid damaging the shell.

The mounting zone in the intermediate lantern ensures that the outer magnet carrier is safely guided during assembly and disassembly. This prevents accidental damage to the outer magnet carrier. By virtue of this design, the outer magnet carrier sheathing requested by API 685 is not required.

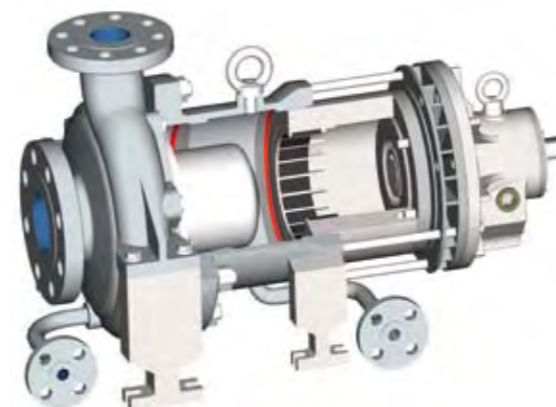

Disassembling the outer magnet carrier tube with rubring zones and stud bolts with lifting lug



# Performance curves SLM AVP

Performance curve 50Hz 1450 min<sup>-1</sup>

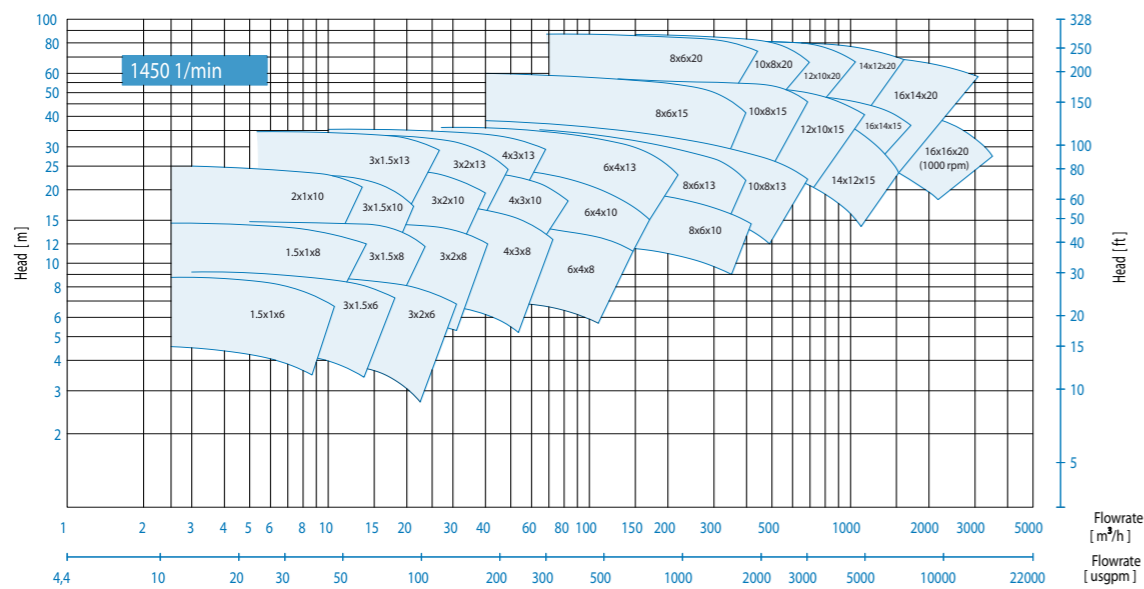

Performance curve 60Hz 1750 min<sup>-1</sup>

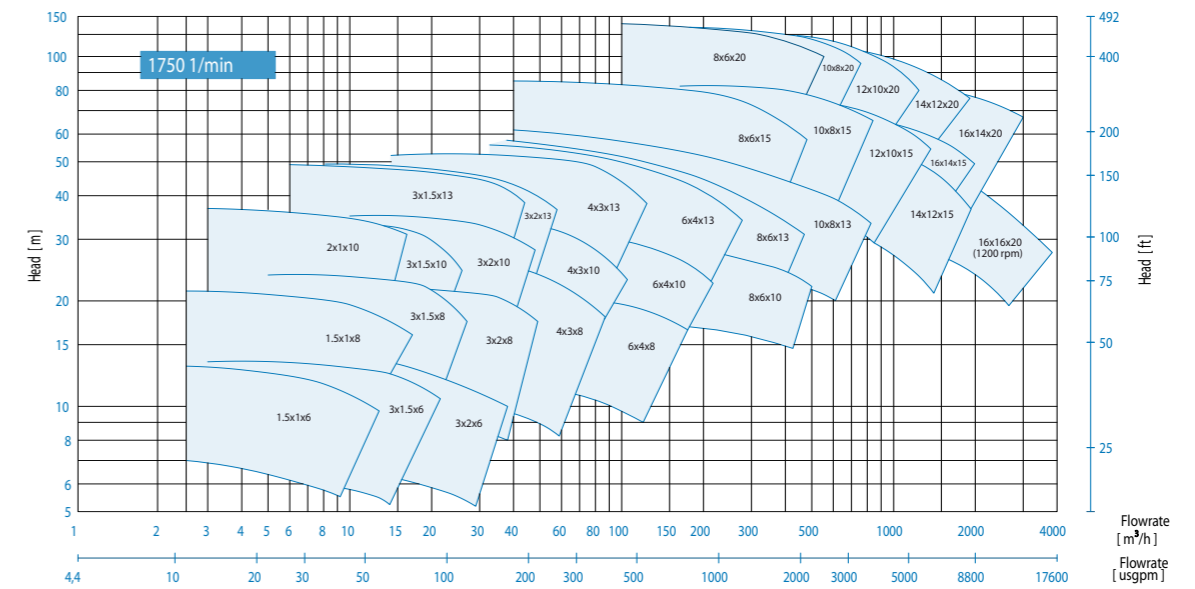

Performance curve 50Hz 2900 min<sup>-1</sup>

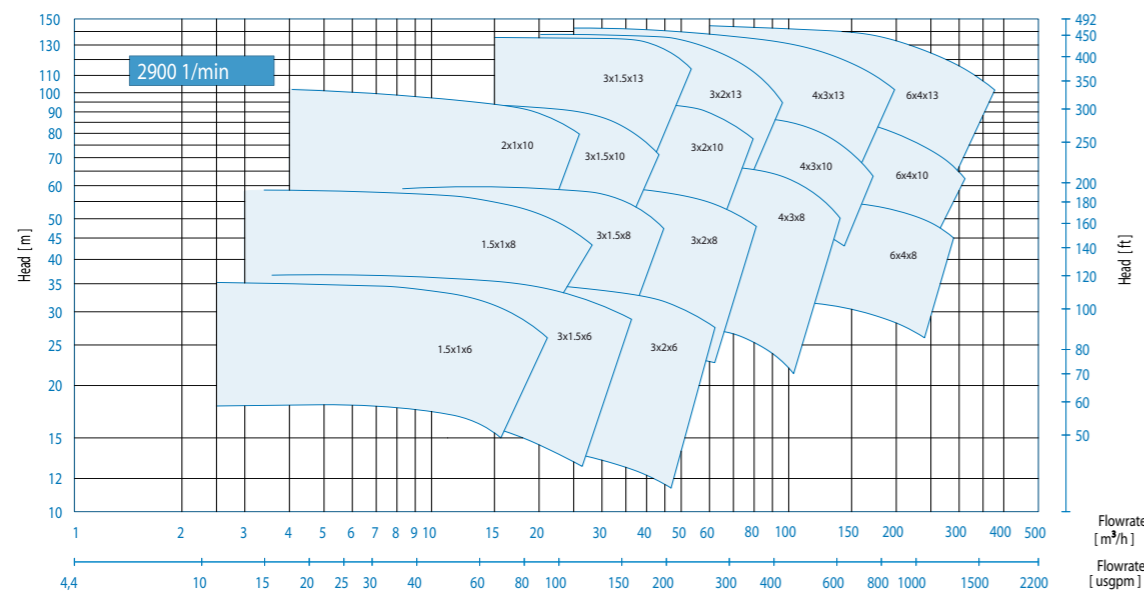

Performance curve 60Hz 3500 min<sup>-1</sup>

