

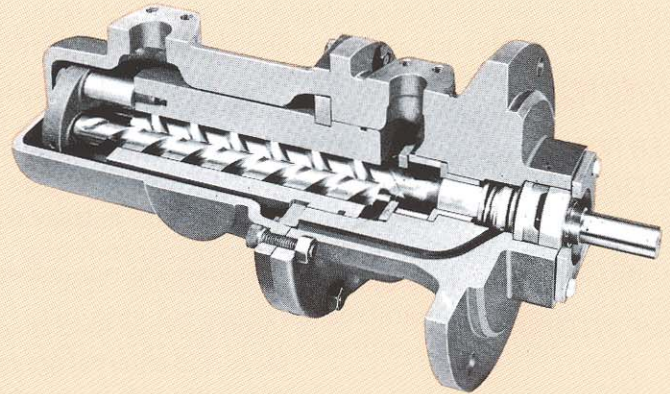

5-200 GPM

Up to 2500 PSI

## Model 6T/6U



IMO Model 6T and 6U pumps are positive displacement, rotary, screw-type pumps designed and engineered for excellent suction capability over a wide range of fluid viscosities. Flow rates (5 to 200 GPM) are proportional to rotating speed when the pump is operated within the recommended pressure range (up to 2500 PSI). The self-priming design permits both evacuation of air filled inlet lines and repriming if suction is lost.

The unique IMO design – only three moving parts – is the key to Model 6T and 6U pump performance. A precision bored housing encases the driven screw (power rotor) and intermeshing sealing screws (idler rotors). The accurately machined idler rotors conform perfectly to the threads of the power rotor and to the housing bores, confining the fluid in a succession of closures or cavities. As the screws rotate, the fluid is moved axially from the inlet port to the outlet port in a continuous, uniform flow. This uniform axial flow results in a minimum of fluid pulsation and extremely quiet operation.

The rotating idler rotors generate a hydrodynamic film of fluid which supports the idlers in the housing bores and prohibits wearing contact. The strength of this film is based on fluid viscosity, pump pressure and speed. As pressure requirements increase, the hydrodynamic film can be strengthened by increasing viscosity or speed. Both the flow rate and

### Applications

Model 6T and 6U pumps are designed to meet the requirements for hydraulic, lubricating, and seal oil applications. These units have been widely utilized in power plants, refineries, petrochemical plants, mechanical transmissions, lubricating and machining center cooling systems – wherever high performance and reliability in a compact design are required.

Typical applications are:

**Lubrication** of diesel engines, gas turbines, steam

pressure capability of the IMO pump increase with speed; thus higher speeds generally result in better performance and longer life.

The symmetrical arrangement of the rotors (screws) eliminates the need for bearings to absorb radial loads. Axial loads are balanced hydraulically within the pump. Model 6T and 6U pumps contain only one ball bearing which positions the power rotor for proper operation of the mechanical seal. This permanently grease-packed bearing is isolated from the pumpage by the mechanical seal to prevent contamination and improper lubrication.

The simple, compact design of the Model 6T and 6U pump permits fast, easy installation, low maintenance, and ease of repair. All wearing parts are completely replaceable. Periodic inspections can be made without removing the pump, and routine maintenance can be performed without disturbing system piping.

Model 6T and 6U pumps are offered in eight rotor and/or lead sizes. A variety of mounting options are available and complete pump/driver assemblies can be provided as required.

**motralec**

4 rue Lavoisier . ZA Lavoisier . 95223 HERBLAY CEDEX

Tel. : 01.39.97.65.10 / Fax. : 01.39.97.68.48

Demande de prix / e-mail : [service-commercial@motralec.com](mailto:service-commercial@motralec.com)

[www.motralec.com](http://www.motralec.com)

turbines and compressors, transmission gears, large centrifugal pumps, and other rotating machinery.

**Supply** of seal oil to gas compressors and hydraulic fluids in fluid power circuits, rolling mills, pulp and paper machinery, and high pressure cooling systems.

**Service** as a hydraulic fluid power pump for control of machine tools, injection molding machinery, turbine governors, fluid power cylinders, shear and punch presses, and die casting machines.

# Specifications and Features

CASING	6T: Cast alloy steel. 6U: High quality close grain cast iron
ROTOR HOUSING	Pearlitic gray iron, Babbitt plated
POWER ROTOR	Alloy steel, nitride hardened and ground.
IDLER ROTORS	Pearlitic gray iron, induction hardened and ground for all sizes of Model 6U and for Model 6T in rotor sizes 137 and 156. Ductile iron, induction hardened and ground, for Model 6T in rotor sizes 187 thru 250.
GASKETS	Cellulose and non-asbestos fiber.
PUMP INTERNALS	Viton bellows mechanical seal, Viton O-rings, carbon on ni-resist mechanical seal faces and external grease packed deep groove ball bearing as standard. Mechanical seal with carbon on carbide seal faces available on Model 6T.
OPERATING PRESSURE	2500 PSIG Maximum. 3000 PSIG under certain conditions. Consult IMO.
INLET PRESSURE	6T: 75 PSIG Maximum (Sizes 137 and 156). All other sizes, 50 PSIG Max. 6U: 50 PSIG Maximum In all cases, discharge pressure must exceed inlet pressure by 50 PSIG.
VISCOSITY	60 – 3000 SSU. Hydraulic oils, lube oils, phosphate ester and water glycol fire resistant fluids can be handled per the standard pump ratings. Anti-wear hydraulic oils are highly recommended. Minimum 60 SSU viscosity fluids permitted, but with reduced maximum pressure capabilities (see Performance Data tables).
TEMPERATURE	0 - 180°, assuming fluid viscosity is within allowed limits.
DRIVE	Direct only with a maximum speed of 5400 RPM for rotor size 118, 4400 RPM for rotor sizes 137 and 156 and 3600 RPM for rotor sizes 187 thru 200. Special pumps available for speeds up to 8000 RPM with boosted inlet. Suction conditions must be checked when operating at increased speeds.
ROTATION	Clockwise facing pump shaft as standard. Optional counterclockwise rotation available.
MOUNTING	May be foot or flange mounted in any attitude. See dimensional drawings, pages 8 and 9.
FILTRATION	Inlet strainers are required to keep contaminants and abrasives out of pump, but they must be selected with consultation with strainer vendor to prevent pump starvation. Normally, 60 mesh for light and 1/8"-3/16" openings for heavy oils are recommended.
CONNECTIONS	SAE 4-bolt inlet and outlet flange. Flanges (socket weld) provided as standard for Model 6T. Inlet head rotatable in 60 degree increments for Model 6U, sizes 137 thru 156; 45 degree increments for Model 6U, sizes 187 thru 250; and 90 degree increments for Model 6T, all sizes.
ACCESSORIES	Adapters for NEMA "C" face motors, completely mounted pump/driver assemblies on steel bedplates, ANSI RF flanged spool pieces, and SAE 4-bolt flanges for 6U models.

# Hydraulic Motor Application

The Model 6T/6U can be used as a hydraulic motor as well as a pump. This is accomplished by reversing the normal direction of flow found when used as a pump.

When the direction of flow is reversed the direction of rotation is also reversed; that is, a clockwise pump will become a counterclockwise motor. Likewise, the low pressure pump inlet becomes the low pressure motor outlet and the high pressure pump outlet becomes the high pressure motor inlet. Like the IMO pump, the IMO motor is a fixed displacement unit. In all cases, the motor inlet pressure should be at least 50 PSI above the outlet pressure, and the outlet pressure should be kept to a minimum.

The IMO motor should be considered for all higher speed applications. Its very quiet operation makes it ideal for such applications as machine tool spindle drives. Although the combination of an IMO motor and gear reducer or belt drive has been successfully used, as a general rule it is not intended for low speed, high torque applications.

Replacement parts are the same for the Model 6T/6U whether it is used as a pump or motor. Since pump and motor performance will differ, the pump performance tables on the following pages should be used only for rough approximations. Consult IMO for exact hydraulic motor performance ratings.

## Typical 6T/6U Assembly

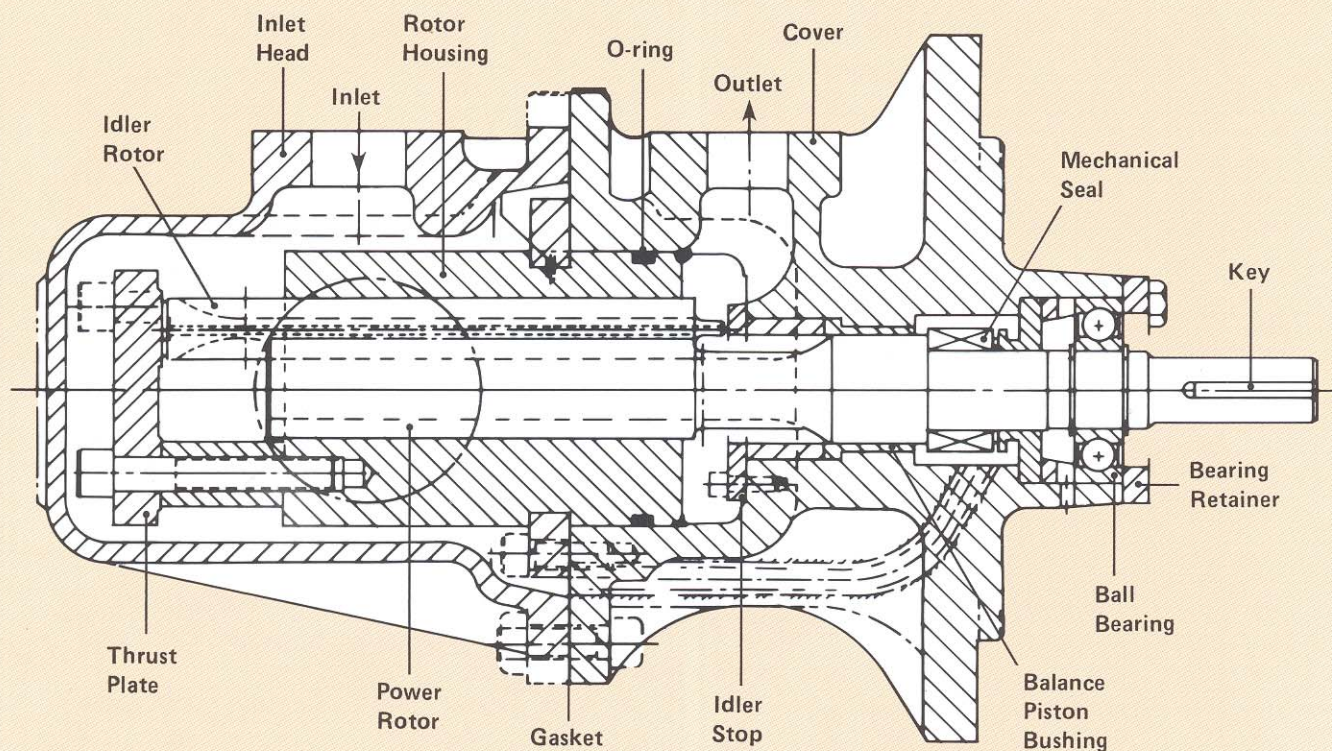

*6UVC-137 (Typical Internals for all models)*

# Performance Data (All Fluids)

<b>6T/6U Rotor Size 118</b>								
Speed 3500 RPM								
Viscosity SSU	Differential Pressure—PSI						Net Inlet Pressure Required PSIA	
	100	500	1000	1500	2000	2500		
GPM	60	19.7	16.6	14.3	12.5	—	—	
	100	20.3	17.9	16.1	14.7	13.5	12.4	
	200	21.3	19.5	18.2	17.2	16.3	15.6	
	650	21.7	20.7	20.0	19.4	19.0	18.5	
	1000	21.8	21.0	20.4	20.0	19.6	19.2	
	3000	22.0	21.5	21.2	20.9	20.7	20.5	
BHP	200	2.4	7.6	14.0	20.5	27.0	33.5	5.5
	650	3.6	8.8	15.2	21.7	28.2	34.7	6.0
	1000	4.3	9.4	15.9	22.4	28.9	35.4	6.0
	3000	7.2	12.3	18.8	25.3	31.8	38.2	7.5
Speed 1750 RPM								
Viscosity SSU	Differential Pressure—PSI						Net Inlet Pressure Required PSIA	
	100	500	1000	1500	2000	2500		
GPM	60	8.6	5.5	—	—	—	—	
	100	9.2	6.8	5.0	—	—	—	
	200	9.9	8.2	6.9	5.9	5.0	—	
	650	10.4	9.5	8.8	8.2	7.7	7.3	
	1000	10.6	9.8	9.2	8.8	8.4	8.0	
	3000	10.8	10.3	10.0	9.7	9.5	9.3	
BHP	200	0.9	3.5	6.8	10.0	13.2	16.5	4.9
	650	1.2	3.8	7.1	10.3	13.5	16.8	5.4
	1000	1.4	4.0	7.2	10.5	13.7	16.9	5.4
	3000	2.1	4.7	8.0	11.2	14.4	17.7	5.9
Speed 2900 RPM (50 Hz)								
Viscosity SSU	Differential Pressure—PSI						Net Inlet Pressure Required PSIA	
	100	500	1000	1500	2000	2500		
GPM	60	15.9	12.8	10.5	—	—	—	
	100	16.5	14.0	12.2	10.9	9.7	8.7	
	200	17.4	15.6	14.3	13.3	12.5	11.7	
	650	17.8	16.9	16.1	15.6	15.1	14.7	
	1000	17.9	17.1	16.6	16.1	15.7	15.4	
	3000	18.1	17.7	17.3	17.1	16.9	16.7	
BHP	200	1.8	6.1	11.5	16.9	22.2	27.6	4.8
	650	2.6	6.9	12.3	17.7	23.0	28.4	5.4
	1000	3.1	7.4	12.8	18.1	23.5	28.9	5.4
	3000	5.1	9.4	14.8	20.1	25.5	30.9	6.2

<b>6T/6U Rotor Size 137</b>								
Speed 3500 RPM								
Viscosity SSU	Differential Pressure—PSI						Net Inlet Pressure Required PSIA	
	100	500	1000	1500	2000	2500		
GPM	60	31.7	27.5	24.4	21.9	—	—	
	100	32.5	29.2	26.8	24.9	23.3	21.9	
	200	33.3	30.9	29.2	27.9	26.8	25.8	
	650	34.1	32.8	31.8	31.1	30.5	29.9	
	1000	34.3	33.3	32.5	31.9	31.4	30.9	
	3000	34.5	33.7	32.9	32.3	31.9	31.6	
BHP	200	3.8	12.0	22.2	32.5	42.7	53.0	6.4
	650	5.7	13.9	24.1	34.3	44.6	54.8	6.7
	1000	6.8	15.0	25.2	35.4	45.7	55.9	7.3
	3000	11.3	19.5	29.8	40.0	50.3	60.5	11.7
Speed 1750 RPM								
Viscosity SSU	Differential Pressure—PSI						Net Inlet Pressure Required PSIA	
	100	500	1000	1500	2000	2500		
GPM	60	14.2	9.9	—	—	—	—	
	100	14.9	11.7	9.2	—	—	—	
	200	15.7	13.4	11.7	10.3	9.2	—	
	650	16.5	15.2	14.3	13.6	12.9	12.4	
	1000	16.7	15.7	14.9	14.3	13.8	13.4	
	3000	16.9	16.3	15.8	15.5	15.2	14.9	
BHP	200	1.5	5.6	10.7	15.8	20.9	—	4.9
	650	1.9	6.0	11.2	16.3	21.4	26.5	4.9
	1000	2.2	6.3	11.4	16.6	21.7	26.8	4.9
	3000	3.4	7.5	12.6	17.7	22.9	28.0	4.9
Speed 2900 RPM (50 Hz)								
Viscosity SSU	Differential Pressure—PSI						Net Inlet Pressure Required PSIA	
	100	500	1000	1500	2000	2500		
GPM	60	25.7	21.5	18.3	—	—	—	
	100	26.5	23.2	20.8	18.9	17.3	15.9	
	200	27.2	24.9	23.2	21.9	20.8	19.8	
	650	28.1	26.8	25.8	25.1	24.5	23.9	
	1000	28.3	27.2	26.5	25.9	25.4	24.9	
	3000	28.5	27.8	27.2	26.9	26.6	26.3	
BHP	200	2.9	9.7	18.2	26.7	35.2	43.6	5.4
	650	4.2	11.0	19.5	28.0	36.4	44.9	5.4
	1000	4.9	11.7	20.2	28.7	37.2	45.7	5.9
	3000	8.1	14.9	23.4	31.9	40.4	48.9	8.3

<b>6T/6U Rotor Size 156</b>								
Speed 3500 RPM								
Viscosity SSU	Differential Pressure—PSI							Net Inlet Pressure Required PSIA
	100	500	1000	1500	2000	2500		
GPM	60	47.1	41.7	37.6	34.5	—	—	
	100	48.1	43.9	40.8	38.3	36.3	34.5	
	200	49.1	46.2	43.9	42.2	40.8	39.5	
	650	50.2	48.5	47.3	46.4	45.6	44.9	
	1000	50.5	49.1	48.1	47.4	46.7	46.2	
	3000	50.7	49.9	49.3	48.9	48.5	48.1	
BHP	200	5.6	17.6	32.6	47.7	62.7	77.7	7.3
	650	8.3	20.3	35.4	50.4	65.4	80.5	7.8
	1000	9.9	21.9	37.0	52.0	67.0	82.1	8.8
	3000	16.6	28.7	43.7	58.7	73.8	88.8	13.2
Speed 1750 RPM								
Viscosity SSU	Differential Pressure—PSI							Net Inlet Pressure Required PSIA
	100	500	1000	1500	2000	2500		
GPM	60	21.4	15.9	—	—	—	—	
	100	22.4	18.2	15.0	12.6	—	—	
	200	23.4	20.4	18.2	16.4	15.0	13.7	
	650	24.4	22.8	21.5	20.6	19.8	19.1	
	1000	24.7	23.4	22.4	21.6	21.0	20.4	
	3000	25.0	24.3	23.7	23.2	22.8	22.5	
BHP	200	2.2	8.2	15.7	23.2	30.7	38.2	4.9
	650	2.8	8.9	16.4	23.9	31.4	38.9	4.9
	1000	3.3	9.3	16.8	24.3	31.8	39.3	4.9
	3000	5.0	11.0	18.5	26.0	33.5	41.1	5.4
Speed 2900 RPM (50 Hz)								
Viscosity SSU	Differential Pressure—PSI							Net Inlet Pressure Required PSIA
	100	500	1000	1500	2000	2500		
GPM	60	38.3	32.9	28.8	25.7	—	—	
	100	39.3	35.1	31.9	29.5	27.5	25.7	
	200	40.3	37.3	35.1	33.4	31.9	30.7	
	650	41.4	39.7	38.5	37.5	36.7	36.0	
	1000	41.6	40.3	39.3	38.5	37.9	37.3	
	3000	41.8	41.1	40.5	40.1	39.7	39.4	
BHP	200	4.3	14.2	26.7	39.1	51.6	64.0	5.9
	650	6.1	16.1	28.6	41.0	53.5	65.9	6.4
	1000	7.3	17.2	29.7	42.1	54.6	67.0	7.3
	3000	11.9	21.9	34.3	46.8	59.2	71.7	9.8

<b>6T/6U Rotor Size 187</b>								
Speed 3500 RPM								
Viscosity SSU	Differential Pressure—PSI							Net Inlet Pressure Required PSIA
	100	500	1000	1500	2000	2500		
GPM	60	82.7	74.9	69.0	64.5	—	—	
	100	84.1	78.1	73.5	70.1	67.1	64.5	
	200	85.6	81.3	78.1	75.6	73.5	71.7	
	650	87.1	84.8	83.0	81.6	80.5	79.4	
	1000	87.5	85.6	84.1	83.0	82.1	81.3	
	3000	87.7	86.5	85.2	84.9	84.3	83.9	
BHP	200	9.6	30.4	56.4	82.3	108	134	9.3
	650	14.3	35.1	61.1	87.1	113	139	10.8
	1000	17.1	37.9	63.9	89.9	115	141	12.7
	3000	28.7	49.5	75.5	101	127	153	14.7
Speed 1750 RPM								
Viscosity SSU	Differential Pressure—PSI							Net Inlet Pressure Required PSIA
	100	500	1000	1500	2000	2500		
GPM	60	38.2	30.4	24.5	—	—	—	
	100	39.6	33.6	29.0	25.5	22.6	—	
	200	41.1	36.8	33.6	31.1	29.0	27.2	
	650	42.6	40.2	38.4	37.1	35.9	34.9	
	1000	43.0	41.1	39.6	38.5	37.6	36.8	
	3000	43.3	42.1	41.4	40.7	40.1	39.7	
BHP	200	3.7	14.1	27.1	40.1	53.1	66.1	4.9
	650	4.9	15.3	28.3	41.3	54.3	67.3	4.9
	1000	5.6	16.0	29.0	42.0	55.0	68.0	5.4
	3000	8.6	19.0	32.0	45.0	58.0	70.9	5.9
Speed 2900 RPM (50 Hz)								
Viscosity SSU	Differential Pressure—PSI							Net Inlet Pressure Required PSIA
	100	500	1000	1500	2000	2500		
GPM	60	67.5	59.6	53.8	49.3	—	—	
	100	68.9	62.8	58.3	54.8	51.9	49.3	
	200	70.3	66.0	62.8	60.4	58.3	56.4	
	650	71.9	69.5	67.7	66.3	65.2	64.2	
	1000	72.2	70.3	68.9	67.8	66.9	66.0	
	3000	72.4	71.2	70.4	69.7	69.2	68.7	
BHP	200	7.3	24.6	46.1	67.6	89.1	110	6.7
	650	10.6	27.8	49.4	70.9	92.4	113	7.8
	1000	12.5	29.8	51.3	72.8	94.3	115	8.8
	3000	20.5	37.8	59.3	80.8	102	123	12.2

1. For conditions between listed values, interpolate between those values. For conditions not listed or off tables. Contact IMO.
2. Net Inlet Pressure Required is minimum pressure above vapor pressure at pump inlet to prevent cavitation. This assumes that the fluid is air and gas free.
3. For BHP values at viscosities below 200 SSU, use values listed for 200 SSU.

# Performance Data (All Fluids)

<b>6T/6U Rotor Size 187P</b>								
Speed 3500 RPM								
Viscosity SSU	Differential Pressure—PSI							Net Inlet Pressure Required PSIA
	100	500	1000	1500	2000	2500		
GPM	60	65.5	58.3	53.0	48.9	—	—	
	100	66.8	61.2	57.1	53.9	51.2	48.9	
	200	68.1	64.2	61.2	59.0	57.1	55.4	
	650	69.5	67.3	65.7	64.4	63.4	62.5	
	1000	69.8	68.1	66.8	65.8	64.9	64.2	
	3000	70.0	68.9	68.2	67.6	67.2	66.7	
BHP	200	8.6	25.2	46.0	66.8	87.5	108	6.7
	650	13.3	29.9	50.7	71.5	92.3	113	7.3
	1000	16.1	32.7	53.5	74.3	95.1	115	8.8
	3000	27.7	44.3	65.1	85.9	106	127	12.7
Speed 1750 RPM								
Viscosity SSU	Differential Pressure—PSI							Net Inlet Pressure Required PSIA
	100	500	1000	1500	2000	2500		
GPM	60	29.8	22.7	17.3	—	—	—	
	100	31.1	25.6	21.5	18.3	—	—	
	200	32.5	28.5	25.6	23.4	21.5	19.8	
	650	33.9	31.7	30.1	28.8	27.8	26.8	
	1000	34.2	32.5	31.1	30.1	29.3	28.5	
	3000	34.5	33.6	32.8	32.3	31.8	31.4	
BHP	200	3.2	11.5	21.9	32.3	42.7	53.1	4.9
	650	4.4	12.7	23.1	33.5	43.9	54.3	4.9
	1000	5.1	13.4	23.8	34.2	44.6	55.0	4.9
	3000	8.1	16.4	26.8	37.2	47.6	58.0	5.4
Speed 2900 RPM (50 Hz)								
Viscosity SSU	Differential Pressure—PSI							Net Inlet Pressure Required PSIA
	100	500	1000	1500	2000	2500		
GPM	60	53.2	46.1	40.7	36.6	—	—	
	100	54.6	49.0	44.9	41.7	39.0	36.6	
	200	55.9	52.0	49.0	46.8	44.9	43.2	
	650	57.3	55.1	53.5	52.2	51.2	50.2	
	1000	57.6	55.9	54.6	53.5	52.7	52.0	
	3000	57.8	56.8	56.1	55.5	55.1	54.7	
BHP	200	6.5	20.3	37.5	54.7	71.9	89.1	5.4
	650	9.8	23.5	40.7	58.0	75.2	92.4	5.9
	1000	11.7	25.5	42.7	59.9	77.1	94.3	6.4
	3000	19.7	33.5	50.7	67.9	85.1	102	9.3

<b>6T/6U Rotor Size 200</b>								
Speed 3500 RPM								
Viscosity SSU	Differential Pressure—PSI							Net Inlet Pressure Required PSIA
	100	500	1000	1500	2000	2500		
GPM	60	100	92.0	85.3	80.2	—	—	
	100	102	95.6	90.4	86.5	83.1	80.2	
	200	104	99.3	95.6	92.8	90.4	88.3	
	650	105	103	101	99.6	98.3	97.1	
	1000	106	104	102	101	100	99.3	
	3000	107	106	105	104	103	103	
BHP	200	11.7	36.9	68.4	99.9	131	163	10.8
	650	17.4	42.6	74.2	105	137	168	12.7
	1000	20.8	46.0	77.5	109	140	172	14.7
	3000	—	—	—	—	—	—	—
Speed 1750 RPM								
Viscosity SSU	Differential Pressure—PSI							Net Inlet Pressure Required PSIA
	100	500	1000	1500	2000	2500		
GPM	60	46.8	37.9	31.3	—	—	—	
	100	48.5	41.6	36.4	32.4	29.1	—	
	200	50.1	45.2	41.6	38.8	36.4	34.3	
	650	51.9	49.1	47.1	45.6	44.2	43.1	
	1000	52.3	50.1	48.5	47.2	46.1	45.2	
	3000	53.0	51.7	50.8	50.1	49.5	48.9	
BHP	200	4.5	17.1	32.9	48.7	64.4	80.2	4.9
	650	6.0	18.6	34.4	50.1	65.9	81.6	5.4
	1000	6.8	19.5	35.2	51.0	66.7	82.5	5.4
	3000	10.4	23.0	38.8	54.6	70.3	86.1	6.4
Speed 2900 RPM (50 Hz)								
Viscosity SSU	Differential Pressure—PSI							Net Inlet Pressure Required PSIA
	100	500	1000	1500	2000	2500		
GPM	60	82.3	73.4	66.8	61.6	—	—	
	100	84.0	77.1	71.9	67.9	64.6	61.6	
	200	85.6	80.7	77.1	74.3	71.9	69.8	
	650	87.4	84.7	82.6	81.1	79.8	78.6	
	1000	87.8	85.6	84.0	82.7	81.7	80.7	
	3000	88.5	87.2	86.3	85.6	85.0	84.5	
BHP	200	8.9	29.8	55.9	82.1	108	134	7.8
	650	12.9	33.8	59.9	86.0	112	138	9.3
	1000	15.2	36.1	62.2	88.4	114	140	10.3
	3000	24.9	45.8	72.0	98.1	124	150	14.7

### 6T/6U Rotor Size 218

Speed 3500 RPM								
Viscosity SSU	Differential Pressure — PSI						Net Inlet Pressure Required PSIA	
	100	500	1000	1500	2000	2500		
GPM	60	132	122	114	108	—	—	Net Inlet Pressure Required PSIA
	100	134	126	120	115	111	108	
	200	136	130	126	123	120	117	
	650	138	135	133	131	129	128	
	1000	139	136	134	133	132	130	
	3000	140	137	136	135	134	134	
BHP	200	15.3	48.3	89.5	130	172	213	12.2
	650	22.8	55.8	97.0	138	179	220	16
	1000	27.2	60.2	101	142	184	225	19.5

Speed 1750 RPM								
Viscosity SSU	Differential Pressure — PSI						Net Inlet Pressure Required PSIA	
	100	500	1000	1500	2000	2500		
GPM	60	62.1	51.4	43.5	—	—	—	Net Inlet Pressure Required PSIA
	100	64.0	55.8	49.6	44.8	40.8	37.3	
	200	66.0	60.2	55.8	52.4	49.6	47.1	
	650	68.1	64.9	62.4	60.6	59.0	57.6	
	1000	68.6	66.0	64.0	62.5	61.3	60.2	
	3000	68.8	67.3	66.2	65.3	64.6	63.9	
BHP	200	5.9	22.4	43.0	63.7	84.3	104	4.9
	650	7.8	24.3	44.9	65.6	86.2	106	5.4
	1000	8.9	25.4	46.1	66.7	87.3	108	5.4
	3000	13.6	30.1	50.8	71.4	92.0	112	7.3

Speed 2900 RPM (50 Hz)								
Viscosity SSU	Differential Pressure — PSI						Net Inlet Pressure Required PSIA	
	100	500	1000	1500	2000	2500		
GPM	60	108	97.0	89.9	83.8	—	—	Net Inlet Pressure Required PSIA
	100	110	102	96.1	91.3	87.3	83.8	
	200	112	106	102	98.9	96.1	93.6	
	650	114	111	108	107	105	104	
	1000	115	112	110	109	107	106	
	3000	116	113	112	111	110	110	
BHP	200	11.7	39.0	73.2	107	141	175	8.8
	650	16.8	44.2	78.4	112	146	180	9.8
	1000	19.9	47.3	81.4	115	149	184	11.3
	3000	32.6	60.0	94.2	128	162	196	15.2

### 6T/6U Rotor Size 250

Speed 3500 RPM								
Viscosity SSU	Differential Pressure — PSI						Net Inlet Pressure Required PSIA	
	100	500	1000	1500	2000	2500		
GPM	60	199	185	175	167	—	—	Net Inlet Pressure Required PSIA
	100	202	191	183	177	172	167	
	200	204	197	191	187	183	180	
	650	207	203	200	197	195	194	
	1000	208	204	202	200	198	197	
	3000	210	208	206	205	204	203	
BHP	200	22.8	72.0	133	195	256	318	19.0
	—	—	—	—	—	—	—	—

Speed 1750 RPM								
Viscosity SSU	Differential Pressure — PSI						Net Inlet Pressure Required PSIA	
	100	500	1000	1500	2000	2500		
GPM	60	94.3	80.4	69.9	61.9	—	—	Net Inlet Pressure Required PSIA
	100	96.8	86.0	78.0	71.8	66.5	61.9	
	200	99.4	91.8	86.0	81.7	78.0	74.7	
	650	102	97.9	94.7	92.3	90.2	88.4	
	1000	103	99.4	96.8	94.9	93.2	91.8	
	3000	104	102	101	99.4	98.4	97.6	
BHP	200	8.8	33.4	64.2	95.0	125	156	5.4
	650	11.7	36.3	67.1	97.9	128	159	5.9
	1000	13.4	38.0	68.8	99.6	130	161	6.4
	3000	20.4	45.0	75.8	106	137	168	9.3

  

Speed 2900 RPM (50 Hz)								
Viscosity SSU	Differential Pressure — PSI						Net Inlet Pressure Required PSIA	
	100	500	1000	1500	2000	2500		
GPM	60	163	149	139	131	—	—	Net Inlet Pressure Required PSIA
	100	166	155	147	141	135	131	
	200	168	161	155	151	147	144	
	650	171	167	164	161	159	157	
	1000	172	168	166	164	162	161	
	3000	173	171	170	169	168	167	
BHP	200	17.4	58.2	109	160	211	262	10.8
	650	25.2	66.0	117	168	219	270	13.5
	1000	29.7	70.5	121	172	223	274	15.8
	—	—	—	—	—	—	—	—

1. For conditions between listed values, interpolate between those values. For conditions not listed or off tables. Contact IMO.
2. Net Inlet Pressure Required is minimum pressure above vapor pressure at pump inlet to prevent cavitation. This assumes that the fluid is air and gas free.
3. For BHP values at viscosities below 200 SSU, use values listed for 200 SSU.



# Model 6UVC Dimensions

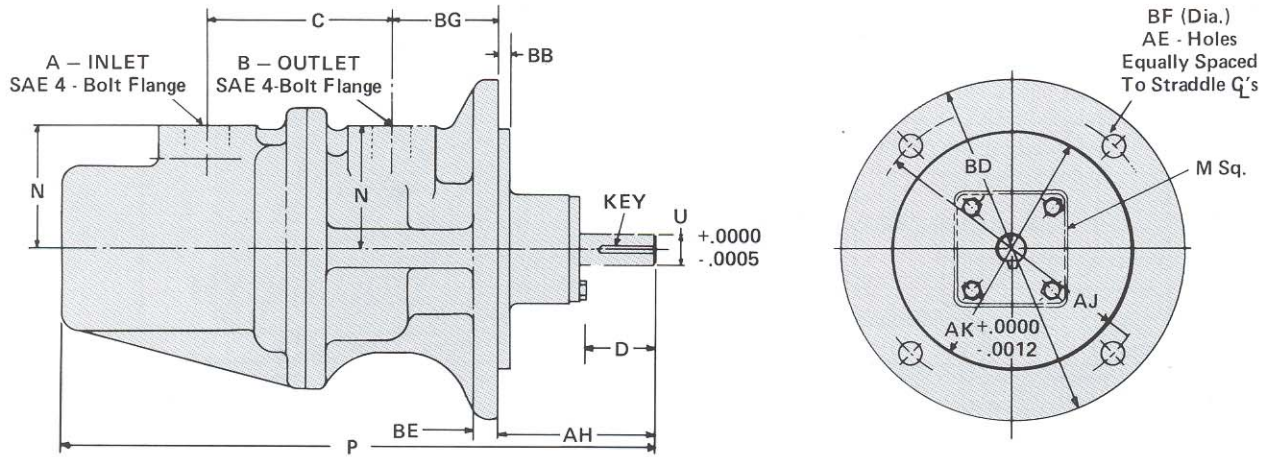

Pump Type	A	B	C	D	M	N	P	U	Key	AE	AH	AJ	AK	BB	BD	BE	BF	BG	Wt. Lbs.
6UVC-118	1-1/2	1	9	2-1/2	3-3/4	4	19-3/4	0.8750	3/16 Sq. x 2	4	4-3/4	9-1/2	7.7494	3/8	11	13/16	11/16	3	120
6UVC-137 6UVC-156	1-1/2	1-1/4	9-3/4	2-1/2	3-3/4	4	22-7/8	1.0000	1/4 Sq. x 1-7/8	4	5-1/8	9-1/2	7.7494	3/8	11	13/16	11/16	3-1/2	150
6UVC-187 6UVC-200	2-1/2	1-1/2	12-1/2	2-7/8	4-1/2	4-3/4	29	1.3750	5/16 Sq. x 2-5/8	8	6-1/2	12-1/4	10.4993	1/2	14	1-1/4	13/16	5	200
6UVC-218 6UVC-250	4	3	17	4-3/16	5-1/2	5-3/4	35-3/8	1.8750	1/2 Sq. x 3-3/8	8	7-3/4	14-1/4	11.9993	1/2	16-1/2	1-1/2	13/16	6	260

# Model 6UVF Dimensions

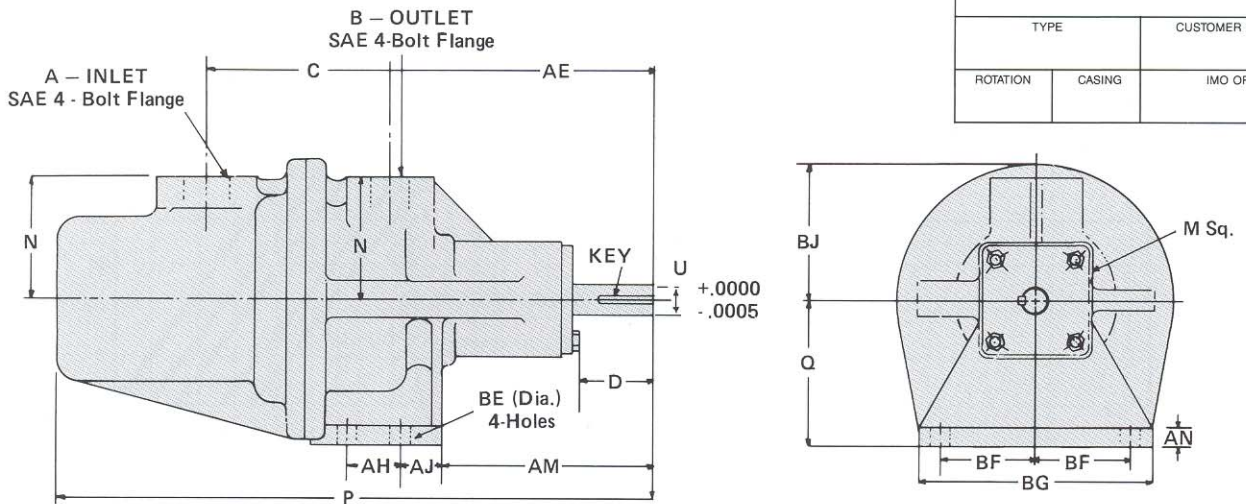

CERTIFIED BY	DATE
CUSTOMER	
TYPE	CUSTOMER ORDER
ROTATION	CASING
IMO ORDER	

Pump Type	A	B	C	D	M	N	P	Q	U	Key	AE	AH	AJ	AM	AN	BE	BF	BG	BJ	Wt. Lbs.
6UVF-118	1-1/2	1	9	2-1/2	3-3/4	4	19-3/4	4-3/4	0.8750	3/16 Sq. x 2	7-3/4	1-3/4	1-3/8	5-1/2	5/8	11/16	3-1/8	7-3/4	4-9/16	125
6UVF-137 6UVF-156	1-1/2	1-1/4	9-3/4	2-1/4	3-3/4	4	22-7/8	4-3/4	1.0000	1/4 Sq. x 1-7/8	8-5/8	1-3/4	1-3/8	6-3/4	5/8	11/16	3-1/8	7-3/4	4-9/16	155
6UVF-187 6UVF-200	2-1/2	1-1/2	12-1/2	2-7/8	4-1/2	4-3/4	29	6-1/4	1.3750	5/16 Sq. x 2-5/8	11-1/2	2-1/4	1-7/8	8-5/8	3/4	13/16	3-1/2	8-3/4	5-3/4	210
6UVF-218 6UVF-250	4	3	17	4-3/16	5-1/2	5-3/4	35-3/8	7-3/4	1.8750	1/2 Sq. x 3-3/8	13-3/4	7-1/2	2-1/8	8-3/8	7/8	13/16	4-5/8	11	7-1/8	275

# Typical Pump/Motor Arrangements

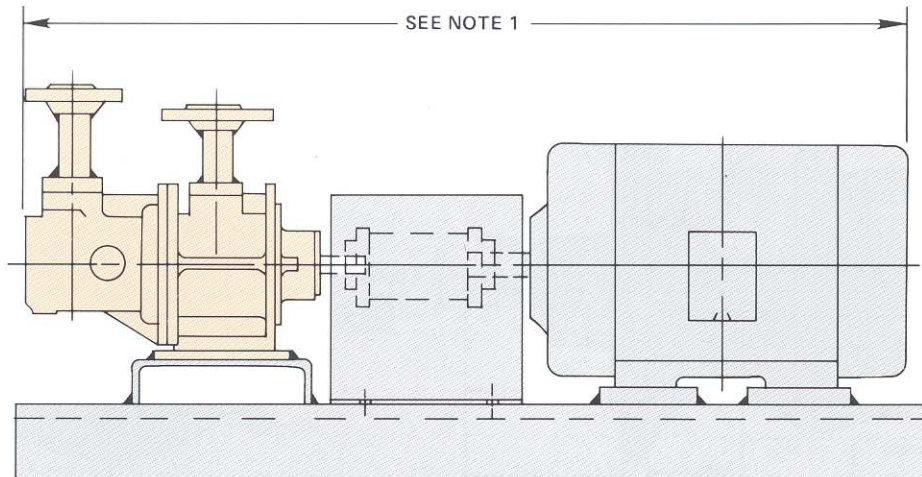

HORIZONTALLY MOUNTED WITH OPTIONAL RF FLANGE SPOOL PIECES

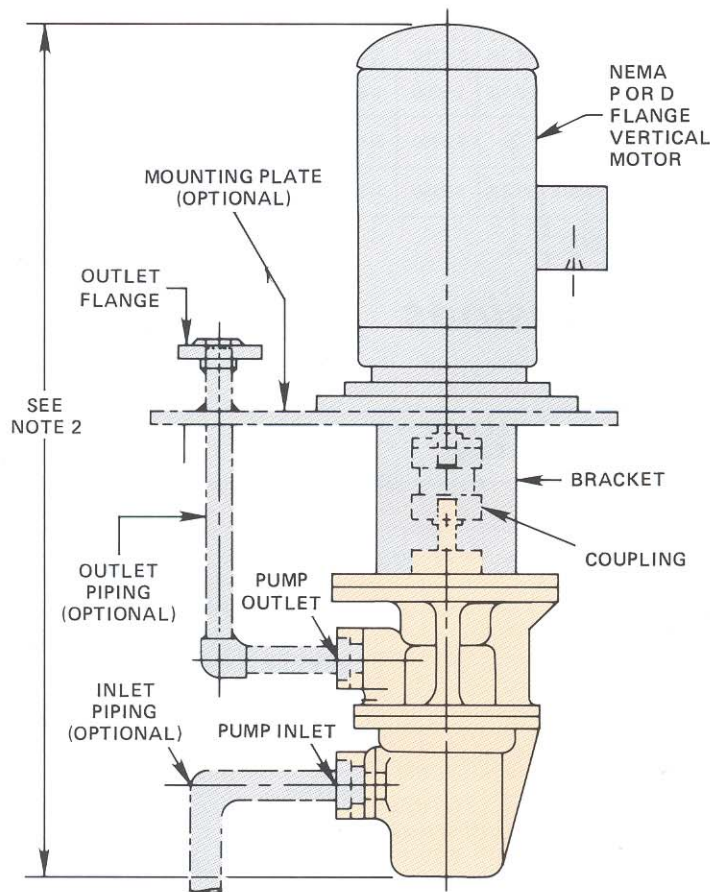

VERTICALLY MOUNTED WITH OPTIONAL DISCHARGE PIPING AND BEDPLATE

## NOTES:

1. Pump/motor assemblies with OSHA type coupling guard and shaft coupling factory mounted on a steel baseplate (with or without driprim) are available upon request.
2. Factory mounted pump/motor assemblies, complete with bracket, shaft coupling plus optional mounting plate, inlet (suction) and outlet (discharge) piping are available upon request.
3. For arrangements or variations not shown, consult IMO.

# Effect of Temperature on Hydraulic Oil Viscosity

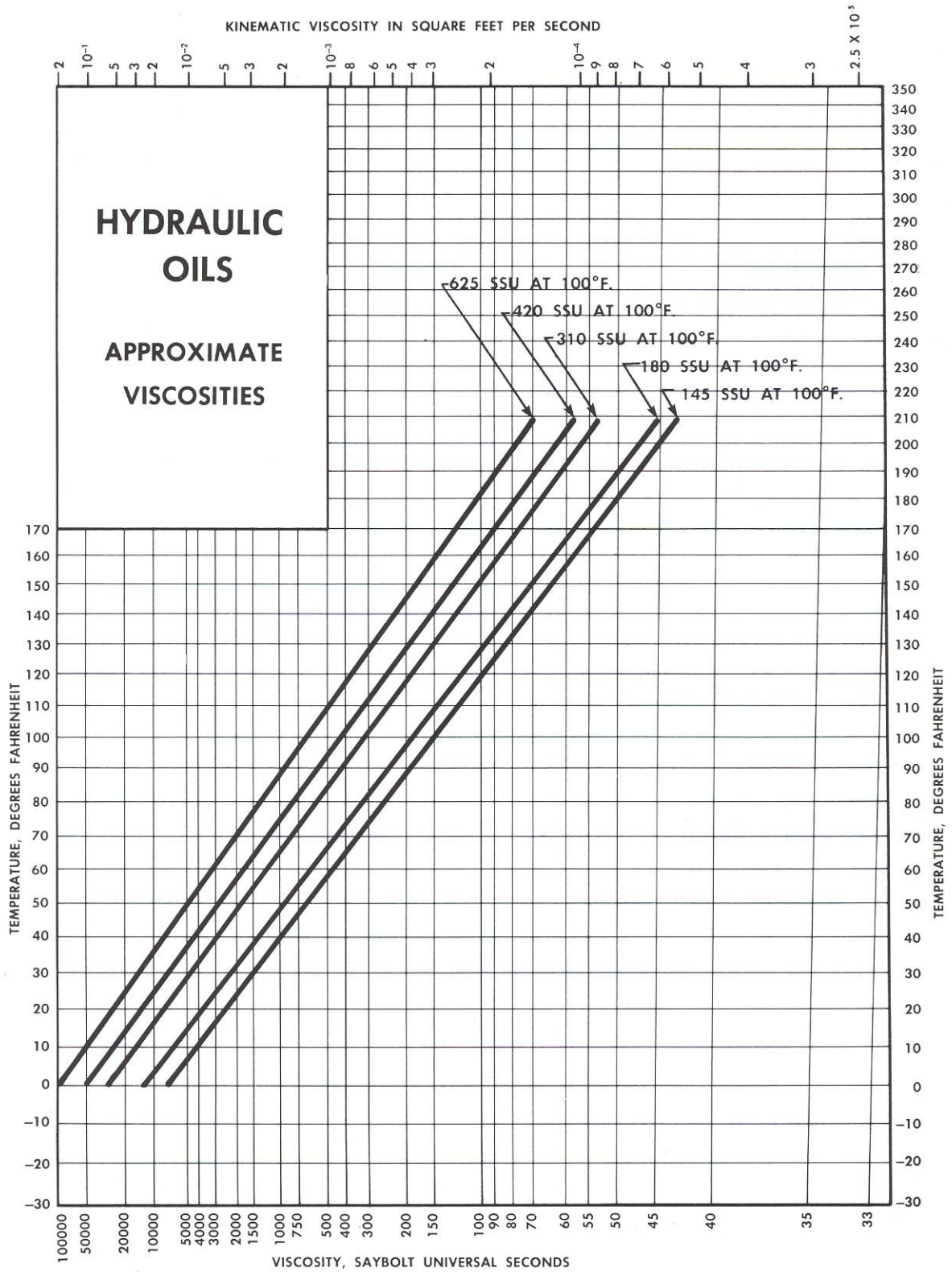

# Typical 6T/6U Nomenclature

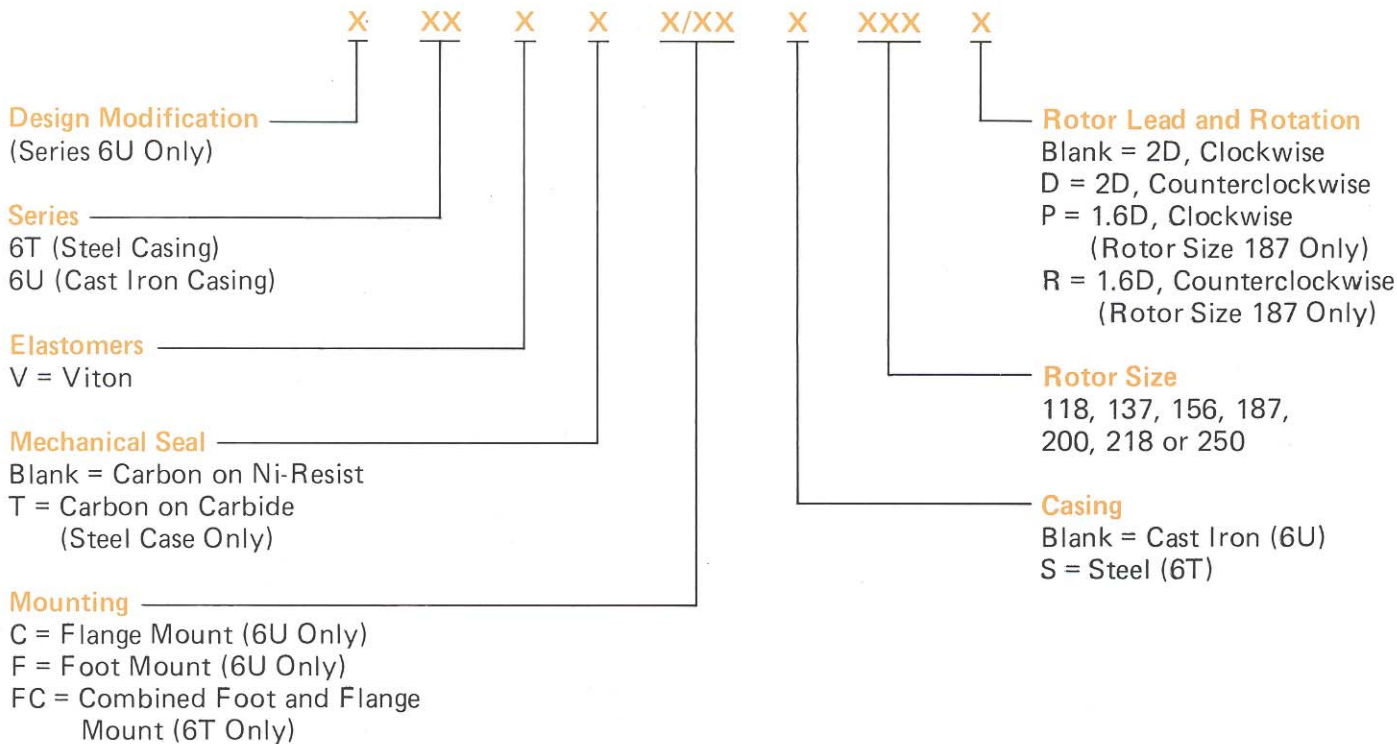

## Examples:

- 6TVTFCS-250D (Steel Casing, Viton Elastomers, Carbon on Carbide Seal Faces, combined Foot or Flange Mount capability, Rotor Size 250, Counterclockwise Rotation)
- 6UVF-137 (Cast Iron Casing, Viton Elastomers, Carbon on Ni-Resist Seal Faces, Foot Mounted, Rotor Size 137, Clockwise Rotation)

\*Consult IMO for optional mechanical seal materials.



## Quality Management System



**Imo Pump**  
 1710 Airport Road  
 PO Box 5020  
 Monroe, NC USA  
 28111.5020

tel 704.289.6511  
 fax 704.289.9273  
 e-mail Imo.Pump@CoffaxCorp.com  
 web WWW.IMO-PUMP.COM

**motralec**

4 rue Lavoisier . ZA Lavoisier . 95223 HERBLAY CEDEX  
 Tel. : 01.39.97.65.10 / Fax. : 01.39.97.68.48  
 Demande de prix / e-mail : service-commercial@motralec.com  
[www.motralec.com](http://www.motralec.com)

For additional sales and service information, contact your local IMO Sales Representative.

©1998 Imo Industries Inc. All rights reserved.