



10-200 GPM

Up to 1500 PSI

Model 4T/4U

IMO Model 4T and 4U pumps are positive displacement, rotary, screw-type pumps designed and engineered for excellent suction capability over a wide range of fluid viscosities. Flow rates (10 to 200 GPM) are proportional to rotating speed when the pump is operated within the recommended pressure range (up to 1500 PSI). The self-priming design permits both evacuation of air filled inlet lines and repriming if suction is lost.

The unique IMO design – only three moving parts – is the key to Model 4T and 4U pump performance. A precision bored housing encases the driven screw (power rotor) and intermeshing sealing screws (idler rotors). The accurately machined idler rotors conform perfectly to the threads of the power rotor and to the housing bores, confining the fluid in a succession of closures or cavities. As the screws rotate, the fluid is moved axially from the inlet port to the outlet port in a continuous, uniform flow. This uniform axial flow results in a minimum of fluid pulsation and extremely quiet operation.

The rotating idler rotors generate a hydrodynamic film of fluid which supports the idlers in the housing bores and prohibits wearing contact. The strength of this film is based on fluid viscosity, pump pressure and speed. As pressure requirements increase, the hydrodynamic film can be strengthened by increasing viscosity or speed. Both the flow rate and

Applications

Model 4T and 4U pumps are designed to meet the requirements for hydraulic, lubricating, and seal oil applications. These units have been widely utilized in power plants, refineries, petrochemical plants, mechanical transmissions, lubricating and machining center cooling systems – wherever high performance and reliability in a compact design are required.

Typical applications are:

Lubrication of diesel engines, gas turbines, steam

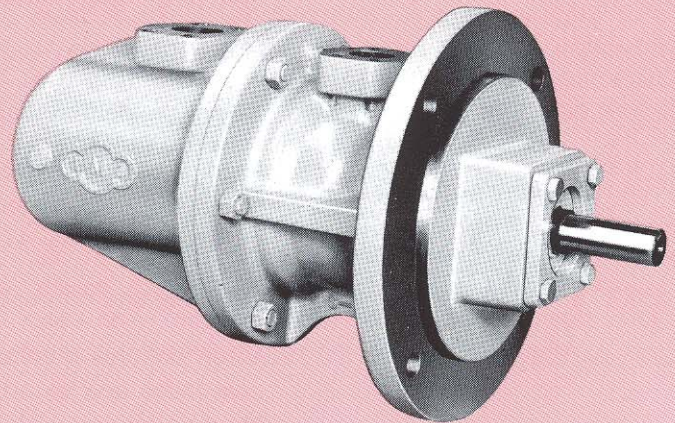

pressure capability of the IMO pump increase with speed; thus higher speeds generally result in better performance and longer life.

The symmetrical arrangement of the rotors (screws) eliminates the need for bearings to absorb radial loads. Axial loads are balanced hydraulically within the pump. Model 4T and 4U pumps contain only one ball bearing which positions the power rotor for proper operation of the mechanical seal. This permanently grease-packed bearing is isolated from the pumpage by the mechanical seal to prevent contamination and improper lubrication.

The simple, compact design of the Model 4T and 4U pump permits fast, easy installation, low maintenance, and ease of repair. All wearing parts are completely replaceable. Periodic inspections can be made without removing the pump, and routine maintenance can be performed without disturbing system piping.

Model 4T and 4U pumps are offered in seven rotor and/or lead sizes. A variety of mounting options are available and complete pump/driver assemblies can be provided as required.

motralec

4 rue Lavoisier . ZA Lavoisier . 95223 HERBLAY CEDEX

Tel. : 01.39.97.65.10 / Fax. : 01.39.97.68.48

Demande de prix / e-mail : service-commercial@motralec.com

www.motralec.com

turbines and compressors, transmission gears, large centrifugal pumps, and other rotating machinery.

Supply of seal oil to gas compressors and hydraulic fluids in fluid power circuits, rolling mills, pulp and paper machinery, and high pressure cooling systems.

Service as a hydraulic fluid power pump for control of machine tools, injection molding machinery, turbine governors, fluid power cylinders, shear and punch presses, and die casting machines.

Specifications and Features

CASING	4T: Cast alloy steel. 4U: High quality close grain cast iron
ROTOR HOUSING	Pearlitic gray iron, babbitt plated
POWER ROTOR	Alloy steel, nitride hardened and ground.
IDLER ROTORS	Pearlitic cast iron, induction hardened and ground, for all sizes of Model 4U and for Model 4T in rotor sizes 137 and 156. Alloy steel, induction hardened and ground, for Model 4T in rotor sizes 187 and 250.
GASKETS	Cellulose and non-asbestos fiber.
PUMP INTERNALS	Viton bellows mechanical seal, Viton O-rings, carbon on ni-resist mechanical seal faces and external grease packed deep groove ball bearing as standard. Mechanical seal with carbon on carbide seal faces available on Model 4T.
OPERATING PRESSURE	1500 PSIG Maximum. 2000 PSIG under certain conditions. Consult IMO.
INLET PRESSURE	4T: 75 PSIG Maximum (Sizes 137 and 156). All other sizes, 50 PSIG Max. 4U: 50 PSIG Maximum In all cases, discharge pressure must exceed inlet pressure by 50 PSIG.
VISCOSITY	60 – 3000 SSU. Hydraulic oils, lube oils, phosphate ester and water glycol fire resistant fluids can be handled per the standard pump ratings. Anit-wear hydraulic oils are highly recommended. Minimum 60 SSU viscosity fluids permitted, but with reduced maximum pressure capabilities (see Performance Data tables).
TEMPERATURE	0 - 180°F, assuming fluid viscosity is within allowed limits.
DRIVE	Direct only with a maximum speed of 4400 RPM for rotor sizes 137 and 156 and 3600 RPM for rotor sizes 187 thru 200. Special pumps available for speeds up to 8000 RPM with boosted inlet. Suction conditions must be checked when operating at increased speeds.
ROTATION	Clockwise facing pump shaft as standard. Optional counterclockwise rotation available.
MOUNTING	May be foot or flange mounted in any attitude. See dimensional drawings, pages 8 and 9.
FILTRATION	Inlet strainers are required to keep contaminants and abrasives out of pump, but they must be selected with consultation with strainer vendor to prevent pump starvation. Normally, 60 mesh for light and 1/8"-3/16" openings for heavy oils are recommended.
CONNECTIONS	SAE 4-bolt inlet and outlet flange. Flanges (socket weld) provided as standard for Model 4T. Inlet head rotatable in 60 degree increments for Model 4U, sizes 137 thru 156; 45 degree increments for Model 4U, sizes 187 thru 250; and 90 degree increments for Model 4T, all sizes.
ACCESSORIES	Adapters for NEMA "C" face motors, completely mounted pump/driver assemblies on steel bedplates, ANSI RF flanged spool pieces, and SAE 4-bolt flanges for 4U models.

Hydraulic Motor Application

The Model 4T/4U can be used as a hydraulic motor as well as a pump. This is accomplished by reversing the normal direction of flow found when used as a pump.

When the direction of flow is reversed the direction of rotation is also reversed; that is, a clockwise pump will become a counterclockwise motor. Likewise, the low pressure pump inlet becomes the low pressure motor outlet and the high pressure pump outlet becomes the high pressure motor inlet. Like the IMO pump, the IMO motor is a fixed displacement unit. In all cases, the motor inlet pressure should be at least 50 PSI above the outlet pressure, and the outlet pressure should be kept to a minimum.

The IMO motor should be considered for all higher speed applications. Its very quiet operation makes it ideal for such applications as machine tool spindle drives. Although the combination of an IMO motor and gear reducer or belt drive has been successfully used, as a general rule it is not intended for low speed, high torque applications.

Replacement parts are the same for the Model 4T/4U whether it is used as a pump or motor. Since pump and motor performance will differ, the pump performance tables on the following pages should be used only for rough approximations. Consult IMO for exact hydraulic motor performance ratings.

Typical 4T/4U Assembly

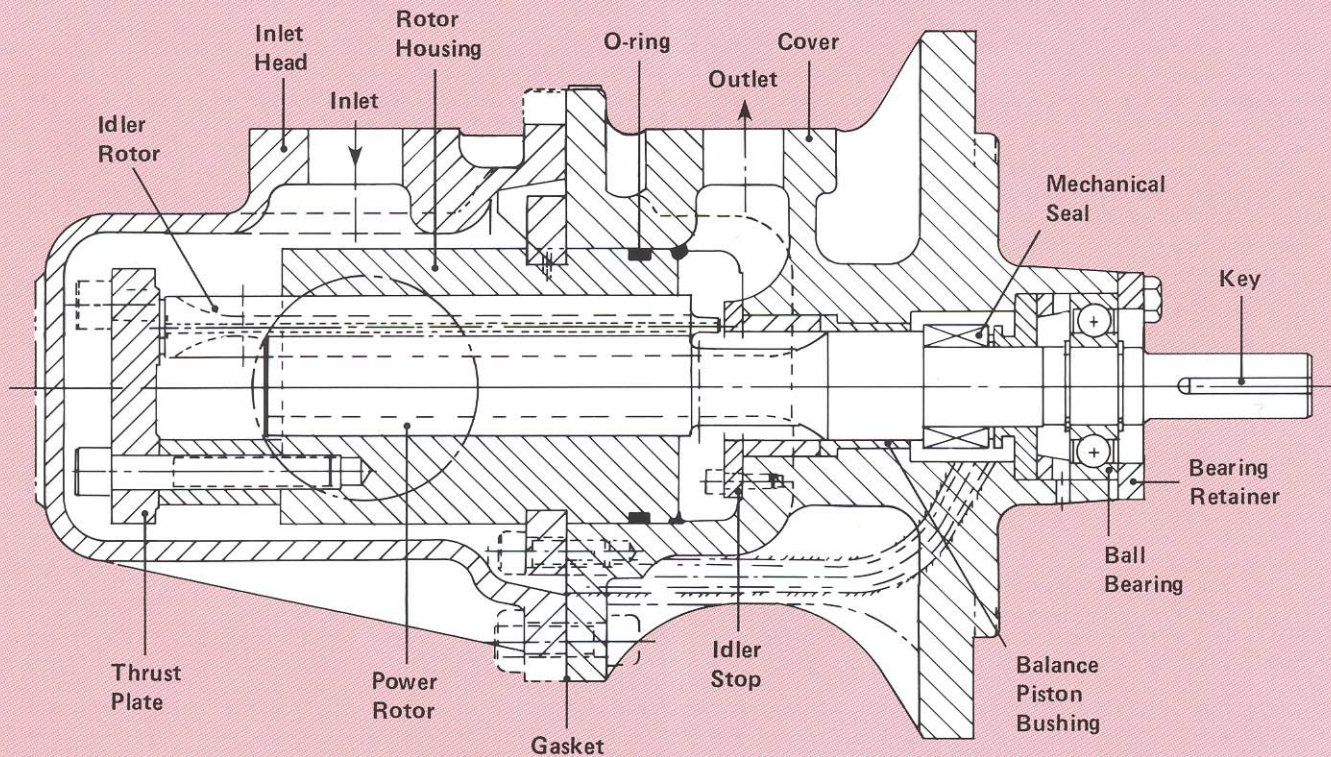

4UVC-137 (Typical Internals for all models)

Performance Data (All Fluids)

4T/4U Rotor Size 137								
Speed 3500 RPM								
Viscosity		Differential Pressure—PSI						Net Inlet Pressure Required PSIA
SSU		100	500	750	1000	1250	1500	
GPM	60	30.7	25.3	23.1	21.2	—	—	
	100	31.7	27.5	25.8	24.4	—	—	
	200	32.7	29.7	28.5	27.5	26.6	25.8	
	650	33.8	32.1	31.5	30.9	30.4	29.9	
	1000	34.0	32.7	32.2	31.7	31.3	30.9	
	3000	34.2	33.4	33.0	32.8	32.5	32.3	
BHP	200	3.3	11.5	16.6	21.7	26.9	32.0	6.4
	650	4.6	12.8	17.9	23.1	28.2	33.3	6.7
	1000	5.4	13.6	18.7	23.9	29.0	34.1	7.3
	3000	8.7	16.9	22.0	27.1	32.2	37.4	11.7
Speed 1750 RPM								
Viscosity		Differential Pressure—PSI						Net Inlet Pressure Required PSIA
SSU		100	500	750	1000	1250	1500	
GPM	60	13.2	—	—	—	—	—	
	100	14.2	9.9	—	—	—	—	
	200	15.2	12.2	11.0	9.9	9.0	—	
	650	16.2	14.6	13.9	13.3	12.8	12.4	
	1000	16.5	15.2	14.6	14.2	13.8	13.4	
	3000	16.8	16.0	15.6	15.4	15.2	14.9	
BHP	200	1.3	5.4	8.0	10.6	13.1	—	4.9
	650	1.7	5.8	8.3	10.9	13.5	16.0	4.9
	1000	1.9	6.0	8.5	11.1	13.7	16.2	4.9
	3000	2.7	6.8	9.4	11.9	14.5	17.1	4.9
Speed 2900 RPM (50 Hz)								
Viscosity		Differential Pressure—PSI						Net Inlet Pressure Required PSIA
SSU		100	500	750	1000	1250	1500	
GPM	60	24.7	19.3	17.1	—	—	—	
	100	25.7	21.5	19.8	18.3	17.1	15.9	
	200	26.7	23.7	22.5	21.5	20.6	19.8	
	650	27.8	26.1	25.4	24.9	24.4	23.9	
	1000	28.0	26.7	26.2	25.7	25.3	24.9	
	3000	28.2	27.4	27.1	26.8	26.6	26.4	
BHP	200	2.6	9.3	13.6	17.8	22.1	26.3	5.4
	650	3.5	10.3	14.5	18.8	23.0	27.2	5.4
	1000	4.0	10.8	15.1	19.3	23.5	27.8	5.9
	3000	6.3	13.1	17.3	21.6	25.8	30.0	8.3

4T/4U Rotor Size 156								
Speed 3500 RPM								
Viscosity		Differential Pressure—PSI						Net Inlet Pressure Required PSIA
SSU		100	500	750	1000	1250	1500	
GPM	60	45.9	38.8	36.0	33.6	—	—	
	100	47.1	41.7	39.5	37.6	36.0	34.5	
	200	48.4	44.6	43.0	41.7	40.5	39.5	
	650	49.8	47.7	46.8	46.1	45.4	44.9	
	1000	50.1	48.4	47.7	47.1	46.6	46.2	
	3000	50.5	49.5	49.1	48.7	48.5	48.2	
BHP	200	4.8	16.9	24.4	31.9	39.4	46.9	7.3
	650	6.8	18.8	26.3	33.8	41.4	48.9	7.8
	1000	7.9	20.0	27.5	35.0	42.5	50.0	8.8
	3000	12.7	24.8	32.3	39.8	47.3	54.8	13.2
Speed 1750 RPM								
Viscosity		Differential Pressure—PSI						Net Inlet Pressure Required PSIA
SSU		100	500	750	1000	1250	1500	
GPM	60	20.1	13.1	—	—	—	—	
	100	21.4	15.9	13.7	—	—	—	
	200	22.7	18.8	17.3	15.9	14.8	13.7	
	650	24.0	21.9	21.0	20.3	19.7	19.1	
	1000	24.4	22.7	22.0	21.4	20.9	20.4	
	3000	24.8	23.9	23.5	23.1	22.8	22.5	
BHP	200	2.0	8.0	11.7	15.5	19.3	23.0	4.9
	650	2.5	8.5	12.2	16.0	19.8	23.5	4.9
	1000	2.8	8.8	12.5	16.3	20.0	23.8	4.9
	3000	4.0	10.0	13.8	17.5	21.3	25.0	5.4
Speed 2900 RPM (50 Hz)								
Viscosity		Differential Pressure—PSI						Net Inlet Pressure Required PSIA
SSU		100	500	750	1000	1250	1500	
GPM	60	37.0	30.0	27.2	24.7	—	—	
	100	38.3	32.9	30.7	28.8	27.2	25.7	
	200	39.6	35.7	34.2	32.9	31.7	30.7	
	650	41.0	38.8	38.0	37.2	36.6	36.0	
	1000	41.3	39.6	38.9	38.3	37.8	37.3	
	3000	41.7	40.7	40.3	39.9	39.6	39.3	
BHP	200	3.7	13.7	19.9	26.2	32.4	38.6	5.9
	650	5.1	15.1	21.3	27.5	33.7	40.0	6.4
	1000	5.9	15.9	22.1	28.3	34.5	40.8	7.3
	3000	9.2	19.2	25.4	31.6	37.9	44.1	9.8

4T/4U Rotor Size 187P

Speed 3500 RPM								
Viscosity SSU	Differential Pressure—PSI						Net Inlet Pressure Required PSIA	
	100	500	750	1000	1250	1500		
GPM	60	64.2	55.4	51.9	48.9	—	—	Net Inlet Pressure Required PSIA
	100	65.8	59.0	56.2	53.9	51.9	50.0	
	200	67.4	62.6	60.6	59.0	57.5	56.2	
	650	69.1	66.4	65.4	64.4	63.6	62.9	
	1000	69.5	67.4	66.5	65.8	65.1	64.5	
	3000	69.7	68.4	67.9	67.5	67.1	66.8	
BHP	200	7.3	23.9	34.3	44.7	55.1	65.5	6.7
	650	10.7	27.3	37.7	48.1	58.5	68.9	7.3
	1000	12.7	29.3	39.7	50.1	60.5	70.9	8.8
	3000	21.0	37.6	48.0	58.4	68.8	79.2	12.7
Speed 1750 RPM								
Viscosity SSU	Differential Pressure—PSI						Net Inlet Pressure Required PSIA	
	100	500	750	1000	1250	1500		
GPM	60	28.5	19.8	—	—	—	—	Net Inlet Pressure Required PSIA
	100	30.1	23.4	20.6	18.3	—	—	
	200	31.7	27.0	25.0	23.4	21.9	20.6	
	650	33.5	30.8	29.7	28.8	28.0	27.3	
	1000	33.9	31.7	30.9	30.1	29.5	28.9	
	3000	34.3	33.1	32.6	32.2	31.8	31.4	
BHP	200	2.9	11.2	16.4	21.6	26.8	32.0	4.9
	650	3.7	12.1	17.2	22.4	27.6	32.8	4.9
	1000	4.2	12.6	17.8	23.0	28.1	33.3	4.9
	3000	6.4	14.7	19.9	25.1	30.3	35.5	5.4
Speed 2900 RPM (50 Hz)								
Viscosity SSU	Differential Pressure—PSI						Net Inlet Pressure Required PSIA	
	100	500	750	1000	1250	1500		
GPM	60	52.0	43.2	39.6	36.6	—	—	Net Inlet Pressure Required PSIA
	100	53.5	46.8	44.0	41.7	39.6	37.8	
	200	55.2	50.4	48.4	46.8	45.3	44.0	
	650	56.9	54.2	53.1	52.2	51.4	50.7	
	1000	57.3	55.2	54.3	53.5	52.9	52.3	
	3000	57.6	56.3	55.8	55.4	55.0	54.7	
BHP	200	5.6	19.4	28.0	36.6	45.2	53.8	5.4
	650	7.9	21.7	30.3	38.9	47.6	56.2	5.9
	1000	9.3	23.1	31.7	40.3	48.9	57.5	6.4
	3000	15.0	28.8	37.4	46.0	54.7	63.3	9.3

4T/4U Rotor Size 187

Speed 3500 RPM								
Viscosity SSU	Differential Pressure—PSI						Net Inlet Pressure Required PSIA	
	100	500	750	1000	1250	1500		
GPM	60	80.9	70.8	66.7	63.2	—	—	Net Inlet Pressure Required PSIA
	100	82.7	74.9	71.7	69.0	66.7	64.5	
	200	84.6	79.0	76.8	74.9	73.2	71.7	
	650	86.6	83.5	82.3	81.2	80.3	79.4	
	1000	87.1	84.6	83.6	82.7	82.0	81.3	
	3000	87.2	85.7	85.2	84.7	84.3	83.9	
BHP	200	8.3	29.1	42.1	55.1	68.1	81.1	9.3
	650	11.7	32.5	45.5	58.5	71.5	84.5	10.8
	1000	13.7	34.5	47.5	60.5	73.5	86.5	12.7
	3000	22.0	42.8	55.8	68.8	81.8	94.8	14.7
Speed 1750 RPM								
Viscosity SSU	Differential Pressure—PSI						Net Inlet Pressure Required PSIA	
	100	500	750	1000	1250	1500		
GPM	60	36.4	26.2	22.1	—	—	—	Net Inlet Pressure Required PSIA
	100	38.2	30.4	27.2	24.5	22.1	—	
	200	40.0	34.5	32.3	30.4	28.7	27.2	
	650	42.0	39.0	37.7	36.7	35.7	34.9	
	1000	42.5	40.0	39.0	38.2	37.4	36.8	
	3000	43.0	41.6	41.0	40.5	40.1	39.7	
BHP	200	3.4	13.8	20.3	26.8	33.3	39.8	4.9
	650	4.3	14.7	21.1	27.6	34.1	40.6	4.9
	1000	4.8	15.2	21.7	28.1	34.6	41.1	5.4
	3000	6.9	17.3	23.8	30.3	36.8	43.2	5.9
Speed 2900 RPM (50 Hz)								
Viscosity SSU	Differential Pressure—PSI						Net Inlet Pressure Required PSIA	
	100	500	750	1000	1250	1500		
GPM	60	65.6	55.5	51.4	47.9	—	—	Net Inlet Pressure Required PSIA
	100	67.5	59.6	56.4	53.8	51.4	49.3	
	200	69.3	63.8	61.5	59.6	58.0	56.4	
	650	71.3	68.2	67.0	65.9	65.0	64.2	
	1000	71.8	69.3	68.3	67.5	66.7	66.0	
	3000	72.0	70.6	70.1	69.5	69.1	68.7	
BHP	200	6.5	23.7	34.5	45.2	56.0	66.7	6.7
	650	8.8	26.0	36.8	47.6	58.3	69.1	7.8
	1000	10.2	27.4	38.2	48.9	59.7	70.5	8.8
	3000	15.9	33.1	43.9	54.7	65.4	76.2	12.2

1. For conditions between listed values, interpolate between those values. For conditions not listed or off tables. Contact IMO.
2. Net Inlet Pressure Required is minimum pressure above vapor pressure at pump inlet to prevent cavitation. This assumes that the fluid is air and gas free.
3. For BHP values at viscosities below 200 SSU, use values listed for 200 SSU.

Performance Data (All Fluids)

4T/4U Rotor Size 200								
Speed 3500 RPM								
Viscosity		Pressure – PSI						Net Inlet Pressure Required PSI
SSU		100	500	750	1000	1250	1500	
GPM	60	98.8	87.3	82.6	78.7	–	–	
	100	100	92.0	88.3	85.3	82.6	80.2	
	200	103	96.7	94.1	92.0	90.1	88.3	
	650	105	101	100	99.1	98.1	97.1	
	1000	105	103	101	100	100	99.3	
BHP	200	10.1	35.4	51.1	66.9	82.6	98.4	10.8
	650	14.2	39.5	55.2	71.0	86.7	102	12.7
	1000	16.6	41.9	57.6	73.4	89.2	104	14.7

Speed 1750 RPM								
Viscosity		Pressure – PSI						Net Inlet Pressure Required PSI
SSU		100	500	750	1000	1250	1500	
GPM	60	44.7	33.2	–	–	–	–	
	100	46.8	37.9	34.3	31.3	28.6	–	
	200	48.9	42.6	40.1	37.9	36.0	34.3	
	650	51.2	47.7	46.3	45.1	44.0	43.1	
	1000	51.8	48.9	47.8	46.8	46.0	45.2	
	3000	52.7	51.1	50.4	49.9	49.4	48.9	
BHP	200	4.1	16.7	24.6	32.5	40.4	48.3	4.9
	650	5.2	17.8	25.7	33.5	41.4	49.3	5.4
	1000	5.8	18.4	26.3	34.2	42.0	49.9	5.4
	3000	8.3	21.0	28.8	36.7	44.6	52.5	6.4

Speed 2900 RPM (50 Hz)								
Viscosity		Pressure – PSI						Net Inlet Pressure Required PSI
SSU		100	500	750	1000	1250	1500	
GPM	60	80.2	68.8	64.1	60.1	–	–	
	100	82.3	73.4	69.8	66.8	64.1	61.6	
	200	84.5	78.2	75.6	73.4	71.5	69.8	
	650	86.7	83.2	81.8	80.6	79.6	78.6	
	1000	87.3	84.5	83.3	82.3	81.5	80.7	
	3000	88.2	86.6	85.9	85.3	84.9	84.4	
BHP	200	7.9	28.8	41.8	54.9	67.9	81.0	7.8
	650	10.7	31.6	44.7	57.7	70.8	83.8	9.3
	1000	12.4	33.3	46.3	59.4	72.4	85.5	10.3
	3000	19.3	40.2	53.3	66.3	79.4	92.5	14.7

4T/4U Rotor Size 218								
Speed 3500 RPM								
Viscosity		Pressure – PSI						Net Inlet Pressure Required PSI
SSU		100	500	750	1000	1250	1500	
GPM	60	130	116	110	106	–	–	
	100	132	122	117	114	110	108	
	200	135	127	124	122	119	117	
	650	138	133	132	130	129	128	
	1000	138	135	134	132	131	130	
BHP	200	13.3	46.3	66.9	87.5	108	128	12.2
	650	18.6	51.6	72.2	92.9	113	134	16.0
	1000	21.8	54.8	75.4	96.0	116	137	19.5

Speed 1750 RPM								
Viscosity		Pressure – PSI						Net Inlet Pressure Required PSI
SSU		100	500	750	1000	1250	1500	
GPM	60	59.6	45.8	40.2	–	–	–	
	100	62.1	51.4	47.1	43.5	40.2	37.3	
	200	64.6	57.1	54.0	51.4	49.2	47.1	
	650	67.3	63.1	61.4	60.0	58.8	57.6	
	1000	68.0	64.6	63.2	62.1	61.1	60.2	
	3000	68.4	66.5	65.7	65.0	64.5	63.9	
BHP	200	5.4	21.9	32.2	42.5	52.8	63.2	4.9
	650	6.8	23.3	33.6	43.9	54.2	64.5	5.4
	1000	7.6	24.1	34.4	44.7	55.0	65.3	5.4
	3000	10.9	27.4	37.7	48.1	58.4	68.7	7.3

Speed 2900 RPM (50 Hz)								
Viscosity		Pressure – PSI						Net Inlet Pressure Required PSI
SSU		100	500	750	1000	1250	1500	
GPM	60	106	92.3	86.7	82.0	–	–	
	100	108	97.9	93.6	89.9	86.7	83.8	
	200	111	103	100	97.9	95.6	93.6	
	650	113	109	107	106	105	104	
	1000	114	111	109	108	107	106	
	3000	114	112	111	111	110	109	
BHP	200	10.3	37.6	54.7	71.8	88.9	106	8.8
	650	14.0	41.3	58.4	75.5	92.6	109	9.8
	1000	16.2	43.5	60.6	77.7	94.8	111	11.3
	3000	25.3	52.6	69.7	86.8	103	121	15.2

4T/4U Rotor Size 250

Speed 3500 RPM

Viscosity		Pressure – PSI						Net Inlet Pressure Required PSI
SSU		100	500	750	1000	1250	1500	
GPM	60	196	178	171	165	–	–	Net Inlet Pressure Required PSI
	100	199	185	180	175	171	167	
	200	203	193	189	185	182	180	
	650	206	201	199	197	195	194	
	1000	207	203	201	199	198	197	
BHP	200	19.8	69.0	99.8	130	161	192	19.0

Speed 1750 RPM

Viscosity		Pressure – PSI						Net Inlet Pressure Required PSI
SSU		100	500	750	1000	1250	1500	
GPM	60	91.0	73.0	65.7	59.6	–	–	Net Inlet Pressure Required PSI
	100	94.3	80.4	74.7	69.9	65.7	61.9	
	200	97.6	87.7	83.7	80.4	77.4	74.7	
	650	101	95.7	93.5	91.6	89.9	88.4	
	1000	102	97.6	95.8	94.3	93.0	91.8	
	3000	103	101	99.5	99.0	98.3	97.5	
BHP	200	8.1	32.7	48.1	63.5	78.9	94.3	5.4
	650	10.1	34.7	50.1	65.5	80.9	96.3	5.9
	1000	11.3	35.9	51.3	66.7	82.1	97.5	6.4
	3000	16.3	40.9	56.3	71.7	87.1	102	9.3

Speed 2900 RPM (50 Hz)

Viscosity		Pressure – PSI						Net Inlet Pressure Required PSI
SSU		100	500	750	1000	1250	1500	
GPM	60	160	142	135	128	–	–	Net Inlet Pressure Required PSI
	100	163	149	144	139	135	131	
	200	166	157	153	149	146	144	
	650	170	165	162	160	159	157	
	1000	171	166	165	163	162	161	
	3000	172	170	169	168	167	166	
BHP	200	15.4	56.2	81.7	107	132	158	10.8
	650	20.9	61.7	87.2	112	138	163	12.7
	1000	24.1	65.0	90.5	116	141	167	15.5

Viscosity Conversion Data

Seconds Saybolt Universal SSU	Kinematic Viscosity Centistokes	Seconds Saybolt Furoil SSF	Seconds Redwood 1 (Standard)	Seconds Redwood 2 (Admiralty)	Degrees Engler
32	1.82	–	30.8	–	1.14
35	2.71	–	32.1	–	1.16
40	4.25	–	36.2	5.10	1.31
50	7.68	–	44.3	5.83	1.58
60	10.3	–	52.3	6.77	1.88
70	13.1	12.95	60.9	7.60	2.17
80	15.7	13.70	69.2	8.44	2.45
90	18.1	14.44	77.6	9.30	2.73
100	20.5	15.24	85.6	10.12	3.02
150	31.9	19.30	128	14.48	4.48
200	43.0	23.5	170	18.90	5.92
250	53.8	28.0	212	23.45	7.35
300	64.6	32.5	254	28.0	8.79
400	86.2	41.9	338	37.1	11.70
500	108	51.6	423	46.2	14.60
600	130	61.4	508	55.4	17.50
700	151	71.1	592	64.6	20.45
800	173	81.0	677	73.8	23.35
900	194	91.0	762	83.0	26.30
1000	216	100.7	896	92.1	29.20
1500	324	150	1270	138.2	43.80
2000	432	200	1690	184.2	58.40
2500	539	250	2120	230	73.0
3000	648	300	2540	276	87.60
4000	862	400	3380	368	117.0
5000	1079	500	4230	461	146
6000	1295	600	5080	553	175
7000	1510	700	5920	645	204.5
8000	1726	800	6770	737	233.5
9000	1942	900	7620	829	263
10000	2160	1000	8460	921	292
15000	3240	1500	13700	–	438
20000	4320	2000	18400	–	584

$$\text{Kinematic Viscosity (in centistokes)} = \frac{\text{Absolute viscosity (in centipoises)}}{\text{Specific Gravity}}$$

Above 300 SSU, use the following conversion:

$$\text{Specific Gravity} = \frac{141.5}{131.5 + \text{API}}$$

$$\text{SSU} = \text{Centistokes} \times 4.635$$

For viscosities beyond the range shown above, the following approximations can be used:

Viscosity Units	Multiplier	
Saybolt Furoil	x 10.	= Viscosity (SSU)
Redwood Standard	x 1.095	= Viscosity (SSU)
Redwood Admiralty	x 10.87	= Viscosity (SSU)
Engler Degrees	x 34.5	= Viscosity (SSU)

1. For conditions between listed values, interpolate between those values. For conditions not listed or off tables. Contact IMO.
2. Net Inlet Pressure Required is minimum pressure above vapor pressure at pump inlet to prevent cavitation. This assumes that the fluid is air and gas free.
3. For BHP values at viscosities below 200 SSU, use values listed for 200 SSU.

Model 4T Dimensions

All Dimensions in Inches
Standard Rotation – Clockwise

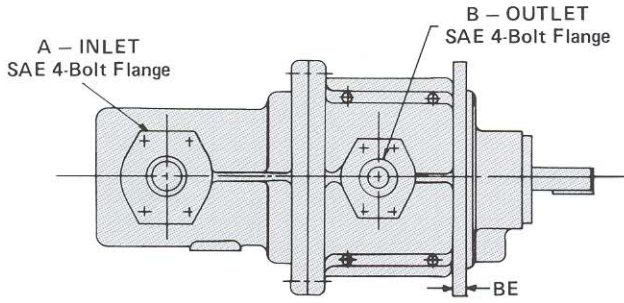

CERTIFIED BY		DATE
CUSTOMER		
TYPE		CUSTOMER ORDER
ROTATION	CASING	IMO ORDER

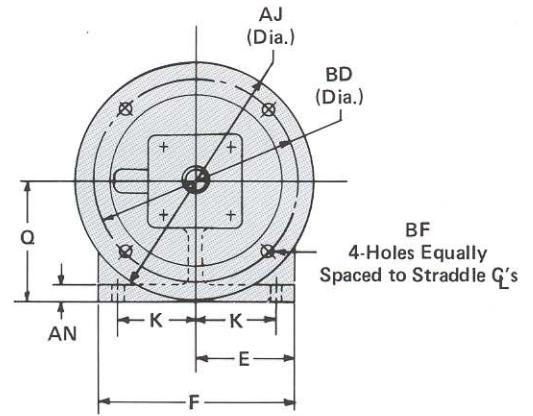
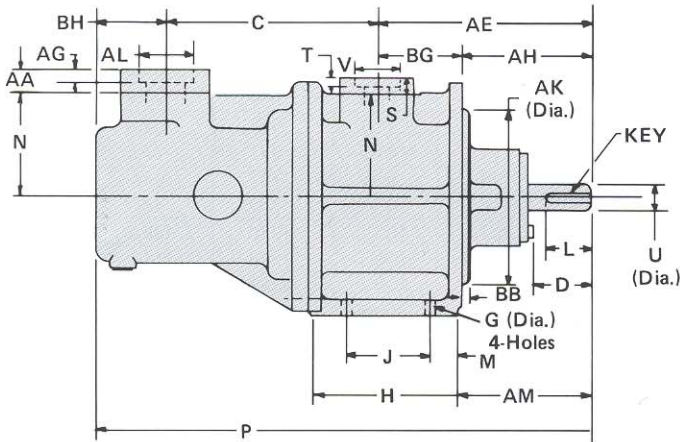

Pump Type	A	B	C	D	E	F	G	H	J	K	L	M	N	P	Q	S	T	U	Key
4T-137	1-1/2	1-1/2	11-3/4	2-1/4	3-7/8	7-3/4	11/16	5	2-1/4	3-1/8	1-7/8	1-3/8	4	22-7/8	4-3/4	1-3/16	3/4	.9995	1/4 x 1/4
4T-156																		1.0000	
4T-187	3	1-1/2	14-1/2	2-7/8	4-3/8	8-3/4	13/16	6-1/4	2-1/4	3-1/2	2-5/8	1-7/8	4-3/4	29	6-1/4	1-3/16	3/4	1.3750	5/16 x 5/16
4T-200																		1.3745	
4T-218	4	3	18	4-3/16	5-1/2	11	13/16	10-5/8	6	4-5/8	3-3/8	2	5-3/4	35-3/8	7-3/4	2-1/8	1-1/4	1.875	1/2 x 1/2
4T-250																		1.874	

Pump Type	V	AA	AE	AG	AH	AJ	AK	AL	AM	AN	BB	BD	BE	BF	BG	BH	Wt. Lbs.
4T-137	1-15/16	1-3/16	8-5/8	3/4	5-7/8	9-1/8	6.2494	1-15/16	6-1/4	5/8	5/16	7-7/8	3/4	9/16	2-3/4	2-1/2	130
4T-156							6.2484										
4T-187	1-15/16	2-1/8	11-1/2	1-1/4	8-3/16	11	7.9994	3-17/32	8-5/8	3/4	3/8	9-1/2	13/16	9/16	3-5/16	3	190
4T-200							7.9982										
4T-218	3-17/32	1-1/2	13-3/4	1-3/8	9-1/4	14-1/4	10.9993	4-37/64	9-1/2	3/4	1/4	12-3/4	1	11/16	4-1/2	3-5/8	240
4T-250							10.9981										

NOTES:

1. All "U" dimensions subject to standard NEMA tolerances.
2. Top inlet position is standard.
3. Removable socket weld flanges included with pump.

Model 4UVC Dimensions

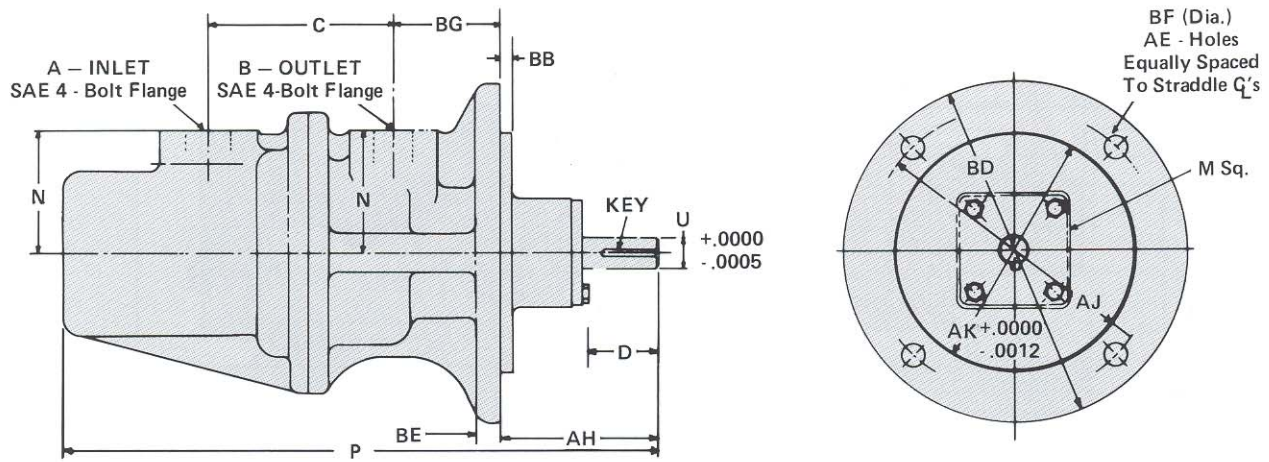

Pump Type	A	B	C	D	M	N	P	U	Key	AE	AH	AJ	AK	BB	BD	BE	BF	BG	Wt. Lbs.
4UVC-137	1-1/2	1-1/4	6	2-1/4	3-3/4	4	19-3/4	1.0000	1/4 Sq. x 1-7/8	4	5-1/8	9-1/2	7.7494	3/8	11	13/16	11/16	3-1/2	120
4UVC-156																			
4UVC-187	2-1/2	1-1/2	9-1/2	2-7/8	4-1/2	4-3/4	25-1/4	1.3750	5/16 Sq. x 2-5/8	8	6-1/2	12-1/4	10.4993	1/2	14	1-1/4	13/16	5	175
4UVC-200																			
4UVC-218	4	3	13	4-3/16	5-1/2	5-3/4	30-3/4	1.8750	1/2 Sq. x 3-3/8	8	7-3/4	14-1/4	11.9993	1/2	16-1/2	1-1/2	13/16	6	220
4UVC-250																			

Model 4UVF Dimensions

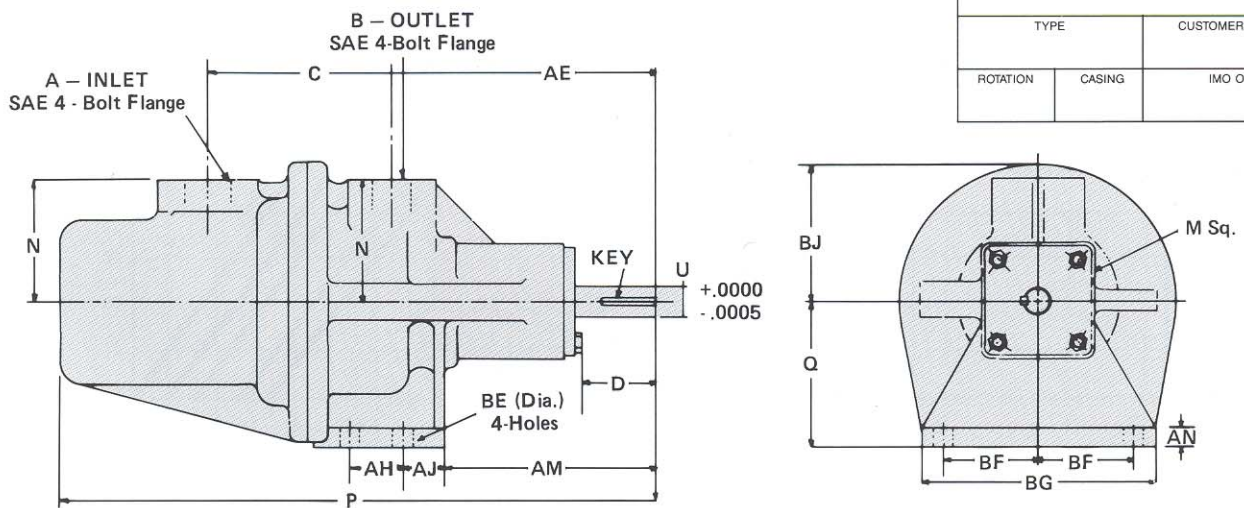

CERTIFIED BY		DATE	
CUSTOMER			
TYPE		CUSTOMER ORDER	
ROTATION	CASING	IMO ORDER	

Pump Type	A	B	C	D	M	N	P	Q	U	Key	AE	AH	AJ	AM	AN	BE	BF	BG	BJ	Wt. Lbs.
4UVF-137	1-1/2	1-1/4	6	2-1/4	3-3/4	4	19-3/4	4-3/4	1.0000	1/4 Sq. x 1-7/8	8-5/8	1-3/4	1-5/8	6-1/2	5/8	11/16	3-1/8	7-3/4	4-9/16	125
4UVF-156																				
4UVF-187	2-1/2	1-1/2	9-1/2	2-7/8	4-1/2	4-3/4	25-1/4	6-1/4	1.3750	5/16 Sq. x 2-5/8	11-1/2	2-1/4	1-7/8	8-5/8	3/4	13/16	3-1/2	8-3/4	5-3/4	185
4UVF-200																				
4UVF-218	4	3	13	4-3/16	5-1/2	5-3/4	30-3/4	7-3/4	1.8750	1/2 Sq. x 3-3/8	13-3/4	7-1/2	2-1/8	8-3/8	7/8	13/16	4-5/8	11	7-1/8	235
4UVF-250																				

Typical Pump/Motor Arrangements

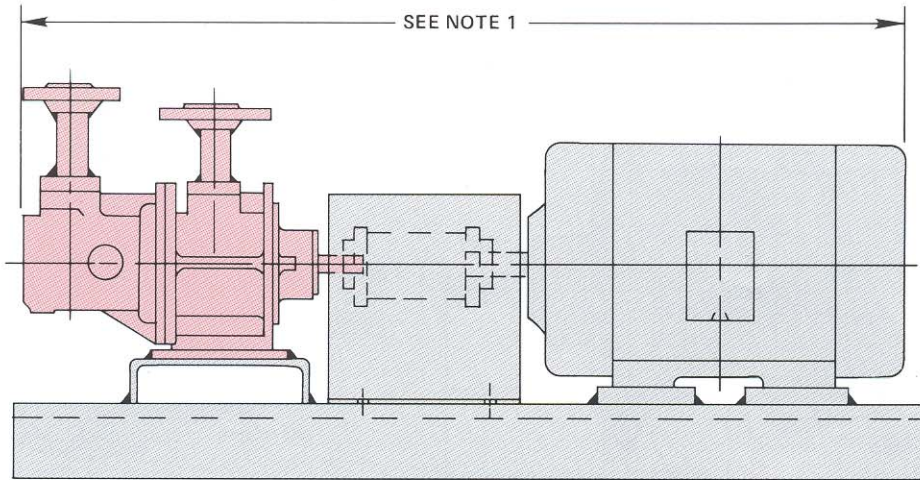

HORIZONTALLY MOUNTED WITH OPTIONAL RF FLANGE SPOOL PIECES

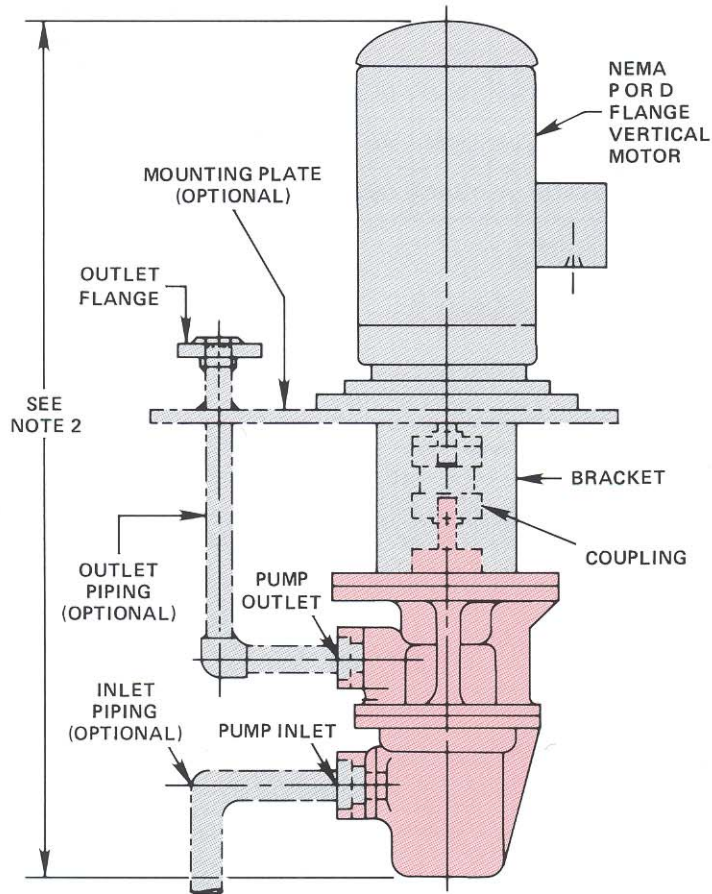

VERTICALLY MOUNTED WITH OPTIONAL DISCHARGE PIPING AND BEDPLATE

NOTES:

1. Pump/motor assemblies with OSHA type coupling guard and shaft coupling factory mounted on a steel baseplate (with or without driprim) are available upon request.
2. Factory mounted pump/motor assemblies, complete with bracket, shaft coupling plus optional mounting plate, inlet (suction) and outlet (discharge) piping are available upon request.
3. For arrangements or variations not shown, consult IMO.

Effect of Temperature on Hydraulic Oil Viscosity

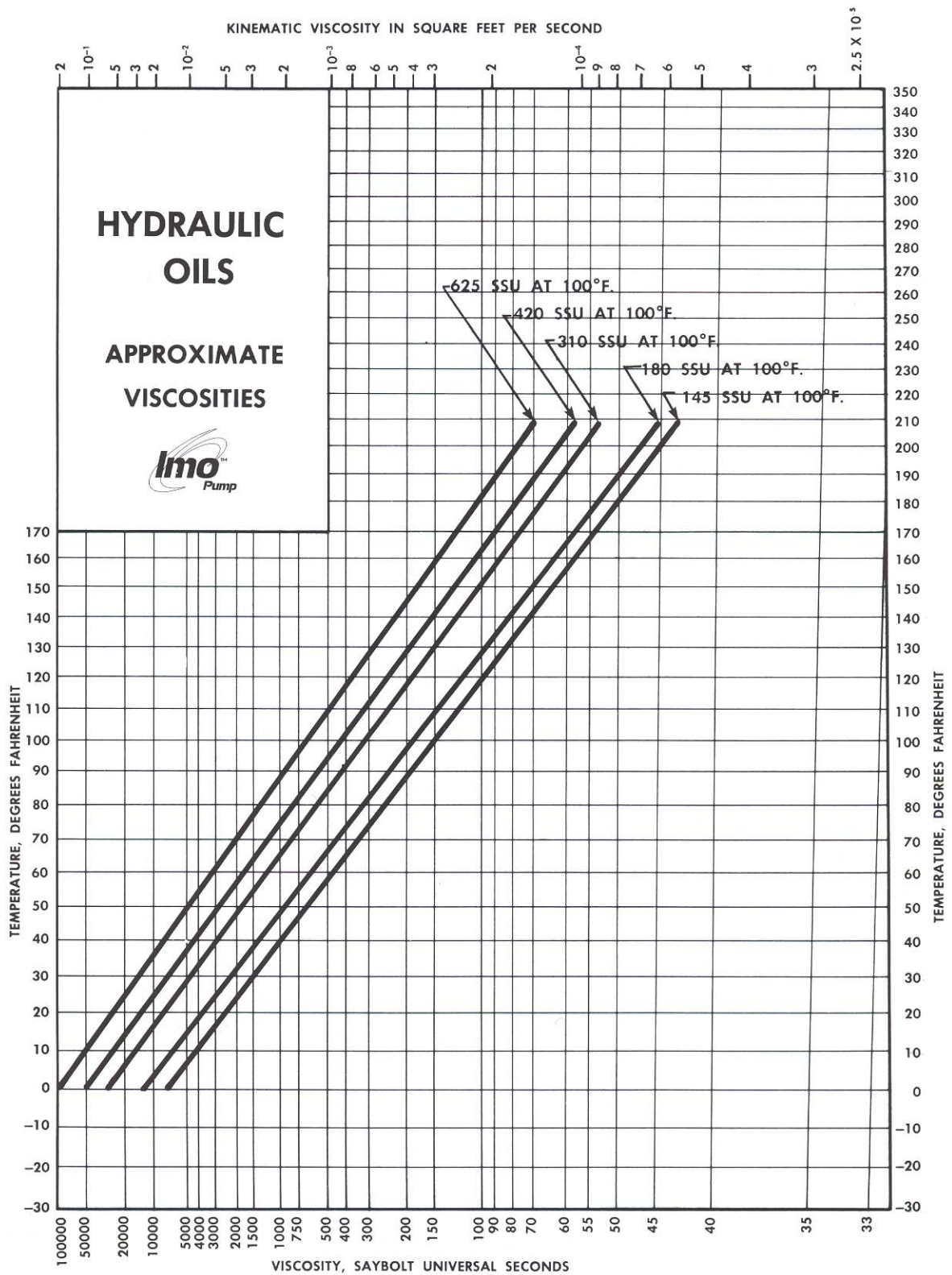

Typical 4T/4U Nomenclature

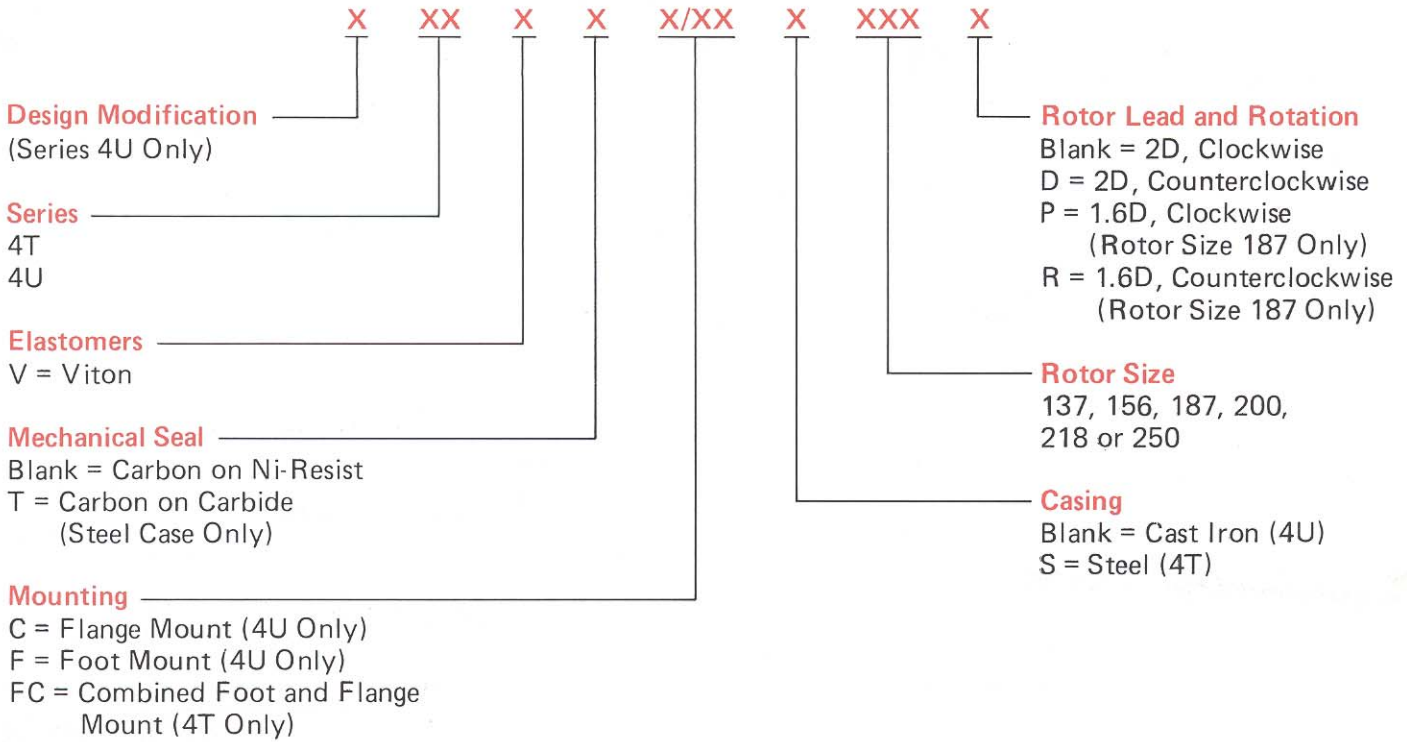

Examples:

- 4TVTFCS-250D (Steel Casing, Viton Elastomers, Carbon on Carbide Seal Faces, combined Foot or Flange Mount capability, Rotor Size 250, Counterclockwise Rotation)
- 4UVF-137 (Cast Iron Casing, Viton Elastomers, Carbon on Ni-Resist Seal Faces, Foot Mounted, Rotor Size 137, Clockwise Rotation)

*Consult IMO for optional mechanical seal materials.



Quality Management System



Imo Pump
 1710 Airport Road
 PO Box 5020
 Monroe, NC USA
 28111.5020

tel 704.289.6511
 fax 704.289.9273
 e-mail Imo.Pump@ColfaxCorp.com
 web WWW.IMO-PUMP.COM

motralec

4 rue Lavoisier . ZA Lavoisier . 95223 HERBLAY CEDEX
 Tel. : 01.39.97.65.10 / Fax. : 01.39.97.68.48
 Demande de prix / e-mail : service-commercial@motralec.com
www.motralec.com

For additional sales and service information, contact your local IMO Sales Representative.