



HYDRA-TECH PUMPS

PORTABLE HYDRAULIC POWER UNIT

MODEL HT50DYS

This hydraulic power unit is powered by a Yanmar diesel engine and is designed to drive several of our pump models including the S6CSL, S6TC and S12M. Other hydraulic tools and equipment that require flows to 25 GPM can also operate from this power unit.

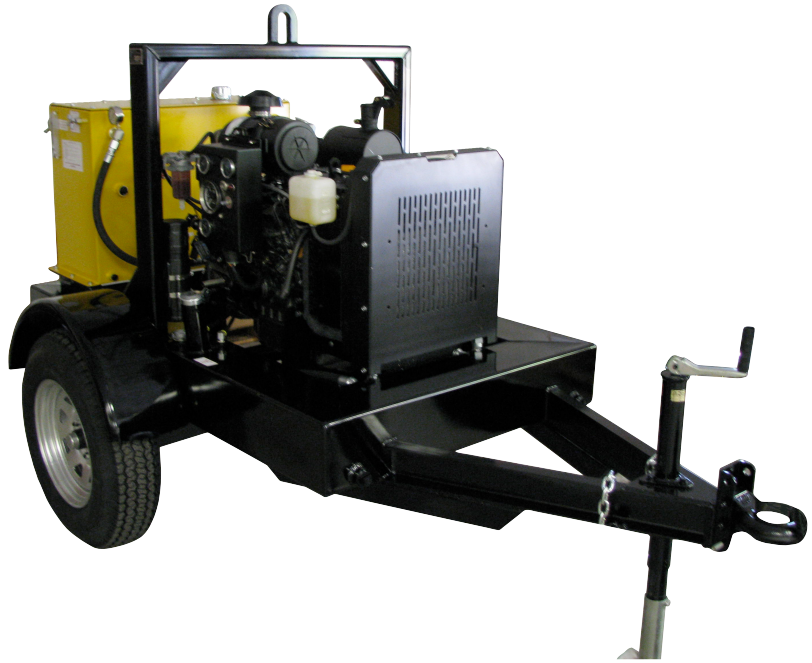

FEATURES

- Highway Trailer Chassis with Built-In Fuel Tank and Independent Suspension
- Single Point Lifting Bracket
- Automatic Engine Safety Shutdown
- Gear-Type Hydraulic Pump
- Hydraulic Oil Cooler
- Variable Speed Control
- Spin-On Return Filter W/ Indicator
- Tank Top Filler/ Strainer
- System Relief Valve
- Pressure Control Valve
- Liquid Filled Pressure Gauge
- Fluid Level/ Temperature Gauge

OPTIONS

- Skid Frame
- Multiple Hydraulic Circuits
- Other Flow and Pressure Combinations

C0110



**HYDRA-TECH
PUMPS**

motralec

4 rue Lavoisier . ZA Lavoisier . 95223 HERBLAY CEDEX

Tel. : 01.39.97.65.10 / Fax. : 01.39.97.68.48

Demande de prix / e-mail : service-commercial@motralec.com

www.motralec.com

Model HT50DYS Overall Dimensions

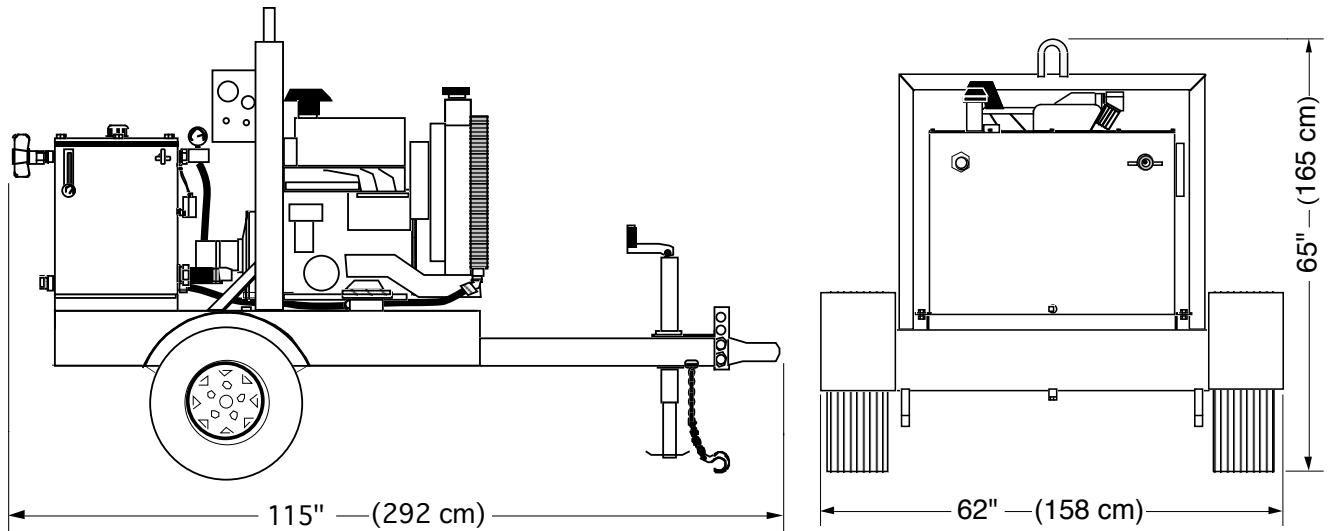

SPECIFICATIONS

ENGINE:..... Yanmar 4TNV84T Liquid Cooled Diesel (Tier 4 Int.)
POWER:..... 55 HP(41 KW) @ 3000 RPM
HYDRAULIC OUTPUT*:..... Variable, Max. 25 GPM (95 LPM)
OPERATING PRESSURE*:..... Maximum 2600 PSI (177 Bar)
HOSE PORT SIZE:..... 1" NPT
HYDRAULIC OIL:..... SAE 10W or 20W (ISO 32 or 46) Type AW
..... also: Biodegradable oil (Consult Factory)
OIL FILTRATION:..... 10 Micron (Standard)
OIL RESERVOIR CAPACITY:..... 50 U.S. Gallons (189 Liters)
FUEL TANK CAPACITY:..... 48 U.S. Gallons (182 Liters)
FUEL CONSUMPTION:..... Approx. 2.5 U.S. Gal/Hr (9.5 Liters/Hr)
DIMENSIONS:..... H 65" (166 cm) x W 62" (158 cm) x L 115" (292 cm)
WEIGHT (Dry):..... 1900 lbs. (860 kg)

* For Flows and Pressures Other Than Standard, Consult Factory

Since we are constantly working to improve our products, specifications are subject to change without notice.