

SERIES 236.40

SCREW PUMP FOR HANDLING CORROSIVE AND ABRASIVE LIQUIDS

APPLICATION AREAS

CHEMICAL INDUSTRY

PETROCHEMICAL INDUSTRY

TAR INDUSTRY

SHIPBUILDING INDUSTRY

MARGARINE INDUSTRY

PAINT AND LACQUER
INDUSTRY

SOAP INDUSTRY

SUGAR INDUSTRY

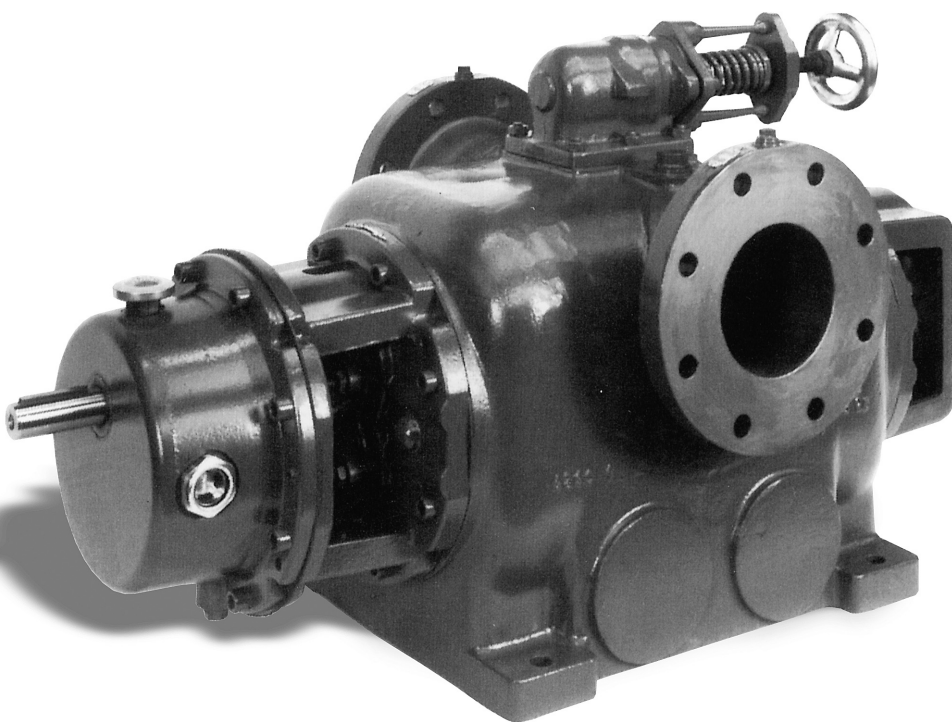

motralec

4 rue Lavoisier . ZA Lavoisier . 95223 HERBLAY CEDEX
Tel. : 01.39.97.65.10 / Fax. : 01.39.97.68.48

Demande de prix / e-mail : service-commercial@motralec.com

www.motralec.com

A COLFAX BUSINESS UNIT



HOUTTUIN B.V.



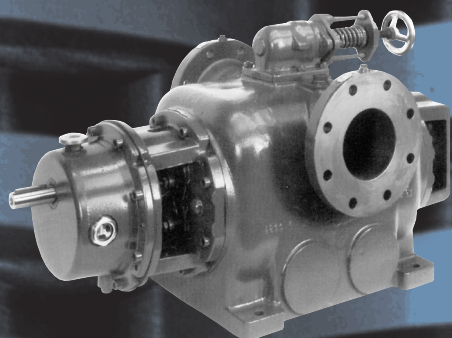

Principle

The Houttuin double entry twin screw pumps series 236 are horizontal rotating self priming positive displacement pumps.

Two inter-meshing screws rotating in a pump casing insert ensure high pumping efficiency with constant axial flow and unequalled suction power.

Construction

The spindles are supported and axially held in position by ball bearings. The transmission of torque from the driven spindle to the idler spindle is effected by oil lubricated timing gears located outside of the pumping area in an attached gearbox. The ball bearings and timing gears maintain a small clearance between the screws, thus preventing metal to metal contact.

Shaft sealing

In standard design the pump can be fitted with single unbalanced mechanical seals or stuffing boxes. If required with fluid chamber for flushing or quenching.

Overload protection

For protection against overload a built-on spring loaded relief valve can be supplied.

Applications

For pumping contaminated or slightly abrasive, lubricating and non-lubricating liquids of low or high viscosity which do not chemically attack the pump materials (corrosion proof materials

can be offered) In the chemical and petro-chemical industry, soap and grease industry, paint and lacquer industry, food and beverage industry, plastics industry, sugar industry, environmental technology, in tankfarms and in the shipbuilding industry.

Performance data

Capacity	Q	up to 1100 m ³ /h
Viscosity range	V	0,6 to 5000 cSt
Temperature of pumped liquid	t	up to 140 °C
Inlet pressure	p _s	up to 10 bar
Outlet pressure	p _d	up to 16 bar
Difference pressure	Δp	up to 16 bar
Speed	n	up to 2900 rpm
Flanges		according to DIN or ANSI

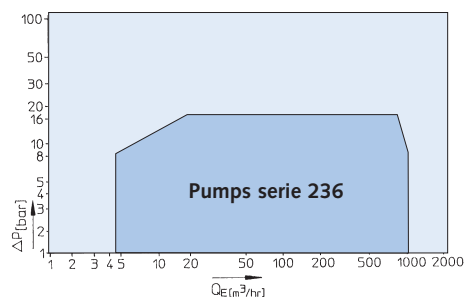

For the exact performance data as function of the viscosity of the liquid to be pumped and the pump speed, please refer to the individual characteristics.

AVAILABLE MATERIALS

FOR PUMP AND MECHANICAL SEALS:

Pump				Mechanical seal according to DIN 24960 / API		
Screw shafts	Casing insert	Casing	Covers	Seal faces	Springs	'O' -rings
- Carbon Steel	- Cast Iron	- Cast Iron	- Cast Iron	- Chrome Steel or	- Stainless	- Viton
- Stainless Steel	- Nodular	- Nodular	- Cast Iron	- Silicon Carbide	Steel	- Teflon
(Type 400)	Cast Iron	Cast Iron	with coating	against	(Type 300)	
- Stainless Steel	- Ni-Resist	- Ni-Resist	- Nodular	- Carbon		
(Type 300)	- Bronze	- Cast Iron	- Carbon Steel			
		with coating	- Stainless Steel			
		- Bronze				
		- Carbon Steel				
		- Stainless Steel				

SHAFT SEALING, STUFFING BOXES

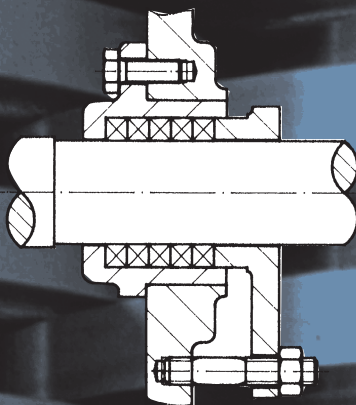

SHAFT SEALING, MECHANICAL SEALS

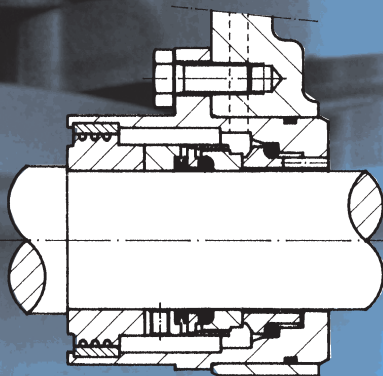
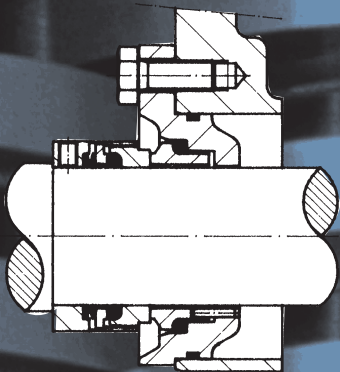

Standard execution

The stuffing boxes are positioned at the suction side of the pump and consequently leakage is negligible

Grease lubrication

The stuffing box is provided with a lantern ring and can be grease-lubricated, to prevent the packing from drying out and to obtain a more efficient shaft sealing.

Standard execution with flushing

Design for grease lubrication.

Mechanical seal

Applicable from $H_s \geq 0.25$ bar abs.

The seal is allowed to run dry for a short period.

Mechanical seal with chamber

The construction of this seal has been developed from the standard construction. A chamber behind the seal offers the possibility of quenching by means of steam, thus preventing the oxidation of liquid eventually leaking through to the atmospheric side of the seal shaftsealing with labyrinth.

The pressure in this chamber may **never** exceed 0.2 bar above lowest H_s ; $H_s \geq 0.45$ bar abs.

Mechanical seal with chamber

As for above, but second shaftsealing with stuffing box.

Mechanical seal with chamber

As for above, but with a lipseal replacing the labyrinth sealing, so that liquids can be used as sealing medium. The pressure in this chamber may **never** exceed 0.2 bar above lowest H_s ; $H_s \geq 0.45$ bar abs.

Mechanical seal

The mechanical seal is provided with a circulation system, so that its cooling and lubrication are safeguarded, even when the pump is running dry.

Mechanical seal with chamber

The construction of this seal has been developed from the construction 60.A chamber behind the seal offers the possibility of quenching by means of steam, thus preventing the oxidation of liquid eventually speaking through to the atmospheric side of the seal. Second shaftsealing with labyrinth. The pressure in this chamber man **never** exceed 0.2 bar above lowest H_s ; $H_s \geq 0.45$ bar abs.

Mechanical seal with chamber

As for above, but second shaftsealing with stuffing box.

Mechanical seal with chamber

As for above, but with a lipseal replacing the labyrinth sealing, so that liquids can be used as sealing medium. The pressure in this chamber may **never** exceed 0.2 bar above lowest H_s ; $H_s \geq 0.45$ bar abs.

Application areas for the processing or the transport in:

CHEMICAL INDUSTRY:

- acids
- alkalis
- additives
- glycerine
- paraffine
- polyethylene
- polyesters
- polybutadiene
- polyisoprene
- styrene
- liquid sulphur
- solvents
- etc.

MARGARINE INDUSTRY:

- animal fats
- vegetable oils
- soap - stock
- filtrates
- margarine
- etc.

PETROCHEMICAL INDUSTRY:

- all kinds of fuel oil and asphalt greases
- additives
- heavy distillation fractions
- slops and slurries
- etc.

SHIPBUILDING INDUSTRY:

- heavy fuel oils
- light products
- bilge/ballast water
- fresh- and seawater
- heavy-transfer oils

SOAP INDUSTRY:

- liquid soaps
- soap-stock
- caustic soda
- fatty acids
- glycerine
- glycol and other polyvalent alcohols
- etc.

SUGAR INDUSTRY:

- molasse
- syrup
- masse-cuite
- etc.

TAR INDUSTRY:

- tar and bitumen
- as well as the sideline products:
- benzene
- toluene
- xylene
- phenol
- aniline
- etc.

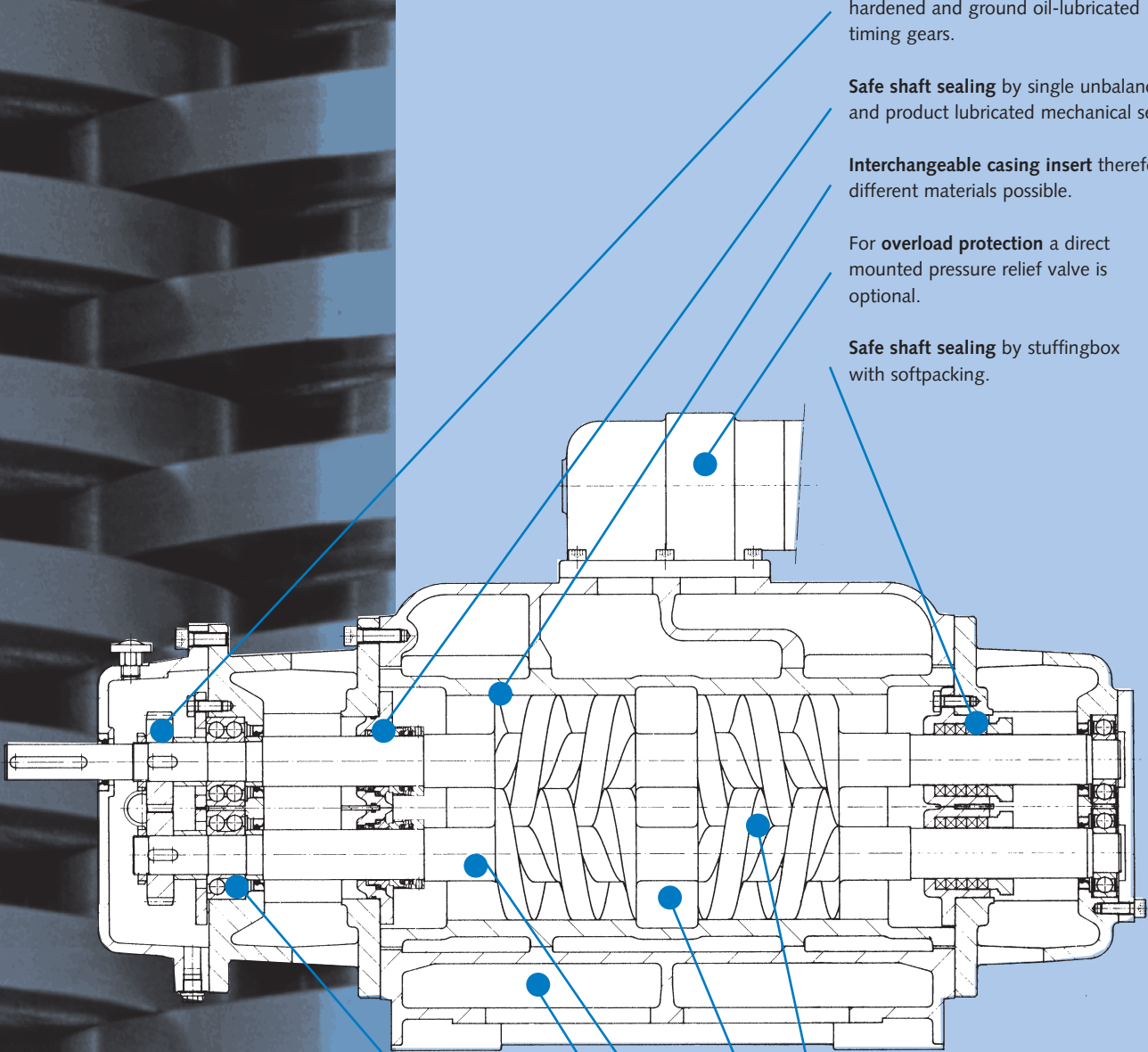

Safe transmission of torque through hardened and ground oil-lubricated timing gears.

Safe shaft sealing by single unbalanced and product lubricated mechanical seals.

Interchangeable casing insert therefore different materials possible.

For **overload protection** a direct mounted pressure relief valve is optional.

Safe shaft sealing by stuffingbox with softpacking.

The special profile of the spindle flanks results in **continuously and nearly pulsation-free pumping, high efficiency, good NPSH- values and constant pressure course.**

Axial forces balanced through double entry spindles.

Heating of the pump foot by means of a medium or electric is optional.

Rigid spindles of solid material therefore compared with multi-part spindles **no crevice corrosion.**

Amplly dimensioned oil lubricated and maintenance free ball bearings, which additionally serve for the axial thrust of the spindles.

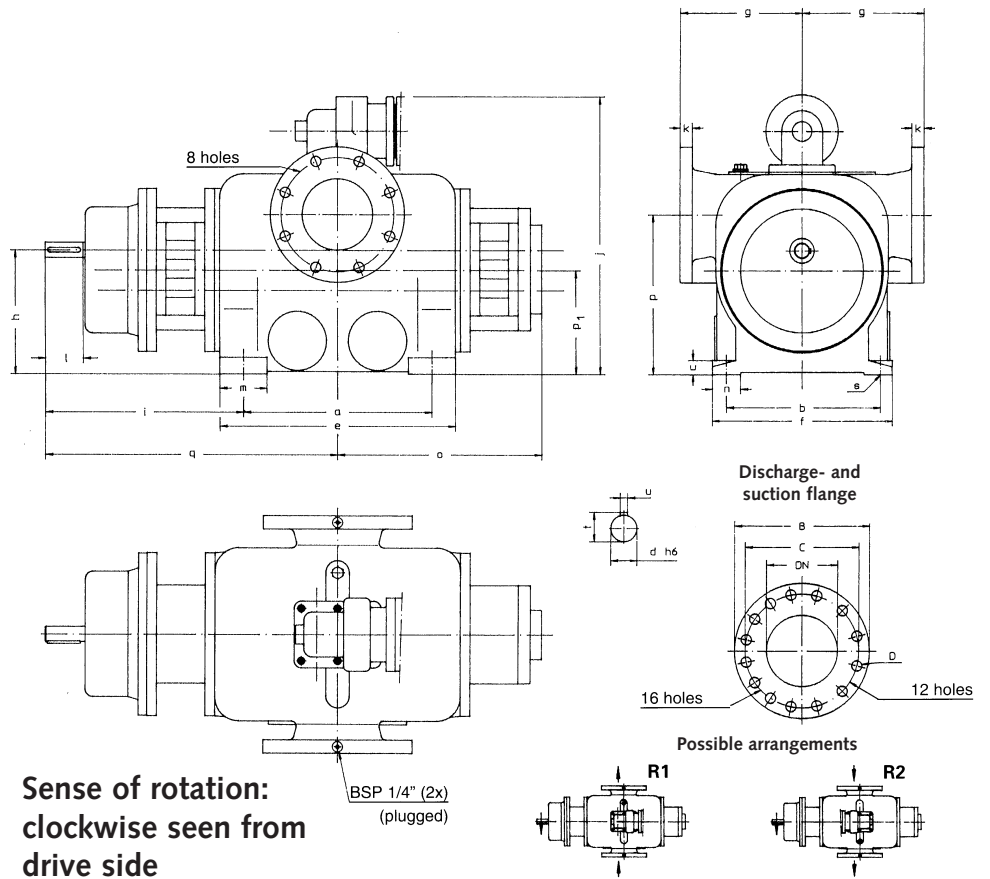

PUMP SIZE	PUMP FOOT DIMENSIONS								FLANGES PN 16 DIN 2533				
	a	b	c	e	f	m	n	s	DN	B	C	D	
088	325	310	35	415	350	90	60	4x18	100	228	180	8x18	46
105	370	330	35	460	370	90	60	4x18	125	254	210	8x18	46
118	400	335	35	500	380	100	60	4x22	150	285	240	8x22	70
135	480	400	40	570	450	100	70	4x22	200	340	295	12x22	70
150	580	450	40	670	500	100	70	4x22	250	405	355	12x26	100
165	620	490	45	740	550	120	90	4x26	250	405	355	12x26	100
180	670	540	45	790	600	120	90	4x26	300	460	410	12x26	100
195	680	590	45	800	650	120	90	4x26	300	460	410	12x26	135
210	690	600	45	840	660	150	120	4x26	300	460	410	12x26	135
225	700	660	45	850	720	150	120	4x26	350	520	470	16x26	135

PUMP SIZE	PUMP DIMENSIONS								SHAFT END					WEIGHT KG (CA)
	g	h	i	j	k	o	p	p1	q	d	l	t	u	
088	230	230	362,5	488	26	380	305	197,5	525	28	60	31	8	165
105	240	245	375	506	26	400	310	207,5	560	28	60	31	8	220
118	250	260	400	610	26	429	335	218	600	32	80	35	10	275
135	275	280	405	655	30	465	355	233	645	38	80	41	10	380
150	300	305	410	805	32	525	400	252,5	745	42	110	45	12	535
165	320	335	500	832	32	576	425	277,5	810	45	110	48,5	14	760
180	350	355	515	897	32	610	465	292	850	50	110	53,5	14	965
195	370	375	520	983	32	627	480	307	860	55	110	59	16	1150
210	390	395	605	1025	32	666	520	321,5	950	60	140	64	18	1400
225	435	415	615	1070	36	677	540	336,5	965	65	140	69	18	1600

dimensions in mm, dimensions are subject to alternations.

*) The diagrams show the performance range of the different pump series in our pump program and are for information only.

STANDARD PUMPS

With Internal Bearings

for lubricating liquids

viscosity range : 20 - 760 cSt
: 98 - 3500 SSU

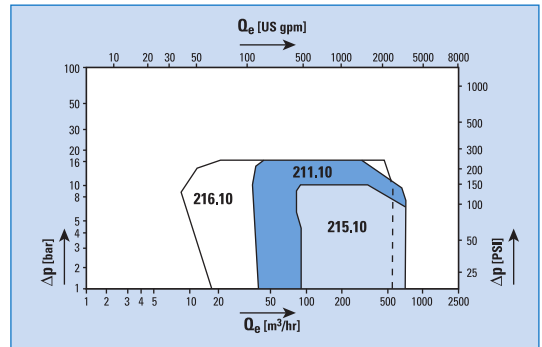

With External Bearings

for non-lubricating liquids

viscosity range : 0,6 - 1500 cSt
: 32 - 7000 SSU

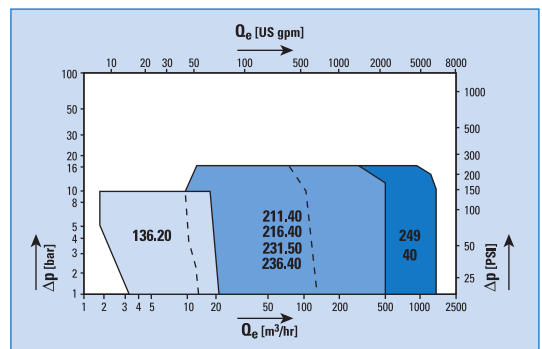

With External Bearings

for lubricating and non-lubricating liquids

viscosity range : 0,6 - 100.000 cSt
: 32 - 466.000 SSU

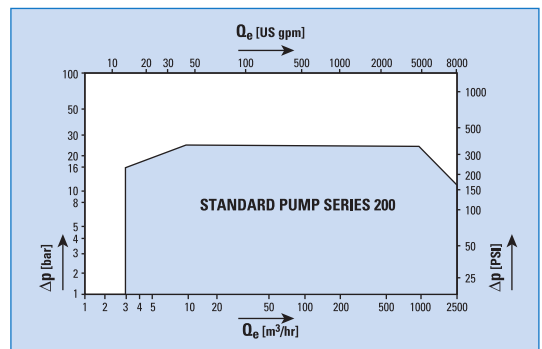

ENGINEERED PUMPS

With External Bearings

for lubricating and non-lubricating liquids

viscosity range : 0,6 - 100.000 cSt
: 32 - 466.000 SSU

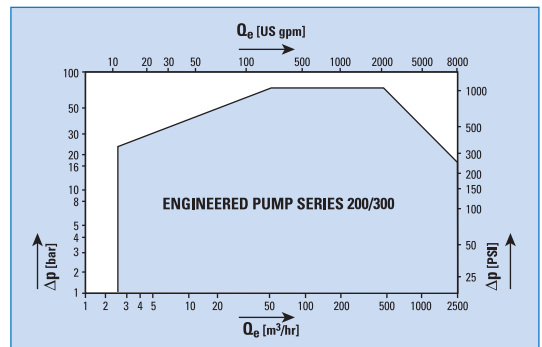

HOUTTUIN B.V.

Sophialaan 4, 3542 AR Utrecht
The Netherlands
P.O. Box 76, 3500 AB Utrecht
The Netherlands
Phone +31 - (0)30 - 2484611
Telefax +31 - (0)30 - 2411845
Telex 47280
Internet <http://www.houttuin.nl>

motralec

4 rue Lavoisier . ZA Lavoisier . 95223 HERBLAY CEDEX
Tel. : 01.39.97.65.10 / Fax. : 01.39.97.68.48
Demande de prix / e-mail : service-commercial@motralec.com
www.motralec.com