

Packaged submersible pump stations with synthetic collection sump

SKB 6, SKB 9

Application

SKB 6 and SKB 9 sumps are pre-assembled submersible pump stations, each with an anti-flotation collection sump for the drainage of buildings from below the sewer level. With the minimum of civil work and installation time it is installed, in open ground, outside the building.

Installing the SKB 6 or SKB 9 is an effective and economical solution for various waste-water and sewage disposal situations. Both pump stations can be supplied with either HOMA submersible series Barracuda GRP sewage pumps with cutting system, or series TP and series TCV/TCM waste-water pumps. For installation according to DIN EN 124 with load classes:

- A 15
- B 125
- D 400

DIN EN 12050-1: Conformity and design approved and controlled by LGA, certificate No. 0220119.

Main features of SKB 6 and SKB 9:

- Complete pump station including pipe work and valves for a quick, simple installation.
- The low weight and compact design makes it easily transportable.
- Various inlets DN 100/150/200 to accommodate specific conditions.
- No-deposit at the sump bottom, achieved by the hanging pump-coupling and spherical base of the sump, designed to prevent build-up.
- Easy pump removal: the pump can be lifted on its own without the discharge pipe.

Design/Equipment supplied

The collection sumps comprises:

Tank: compact polyethylene tank with anti-flotation design. SKB 6 with 3, SKB 9 with 5 tank connections DN 100/ DN 150 inlets including combined cable duct/ air vent and 1 for DN 200 inlet. Discharge pipe outlet. Frame for height support ring or access cover.

Pump Discharge Equipment: Auto-coupling system for 1 or 2 pumps with double guide rails (for pump-coupling flange see „Accessories“). Galvanized discharge with screw connections. One or two soft-sealing ball check valves, gate valve. Discharge flush-cleaning connection with Storz-quick coupling. Threaded tank discharge connection BSP 1½" M.



Pump Types

Pump range	Spherical clearance (mm)	Impeller design	Motor-output P ₂ (kW)	H max. (m)	Q max. (m ³ /h)	Pump discharge size
TP 30 M	30	Single channel	0,7 – 1,2	14 – 19	33 – 43	BSP 2" M
TP 30 V	30	Vortex	0,9 – 1,2	9 – 13	32 – 38	BSP 2" M
TP 50 M	50	Single channel	0,8 – 4,4	7,5 – 32	42 – 82	BSP 2½" M
TP 50 V	50 – 65	Vortex	1,0 – 4,4	8 – 22	41 – 53	BSP 2½" M
TCV	40 – 65	Vortex	0,6 – 1,1	7 – 10	18 – 33	BSP 2" F
TCM	65	Single channel	1,0 – 1,5	12 – 15	38 – 48	BSP 2½" F
GRP	-	Cutting system	1,1 – 4,4	20 – 52	15 – 28	BSP 2" M

For further information see specific pump literature .

Materials:

Tank	Polyethylene
Pump	Cast iron
coupling system	GG25/EN-GJL-250 coated
Guide rails	Stainless steel
Discharge pipe, screw connections	Galvanized steel

Sump Types

Type	No. of pumps	Ref. No.
SKB6-45/1	1	9821035
SKB6-45/2	2	9821037
SKB9-45/1	1	9821015
SKB9-45/2	2	9821017

Dimensions

SKB 6-45/1(2) + SKB 9-45/1(2)
Single- and twin pump station

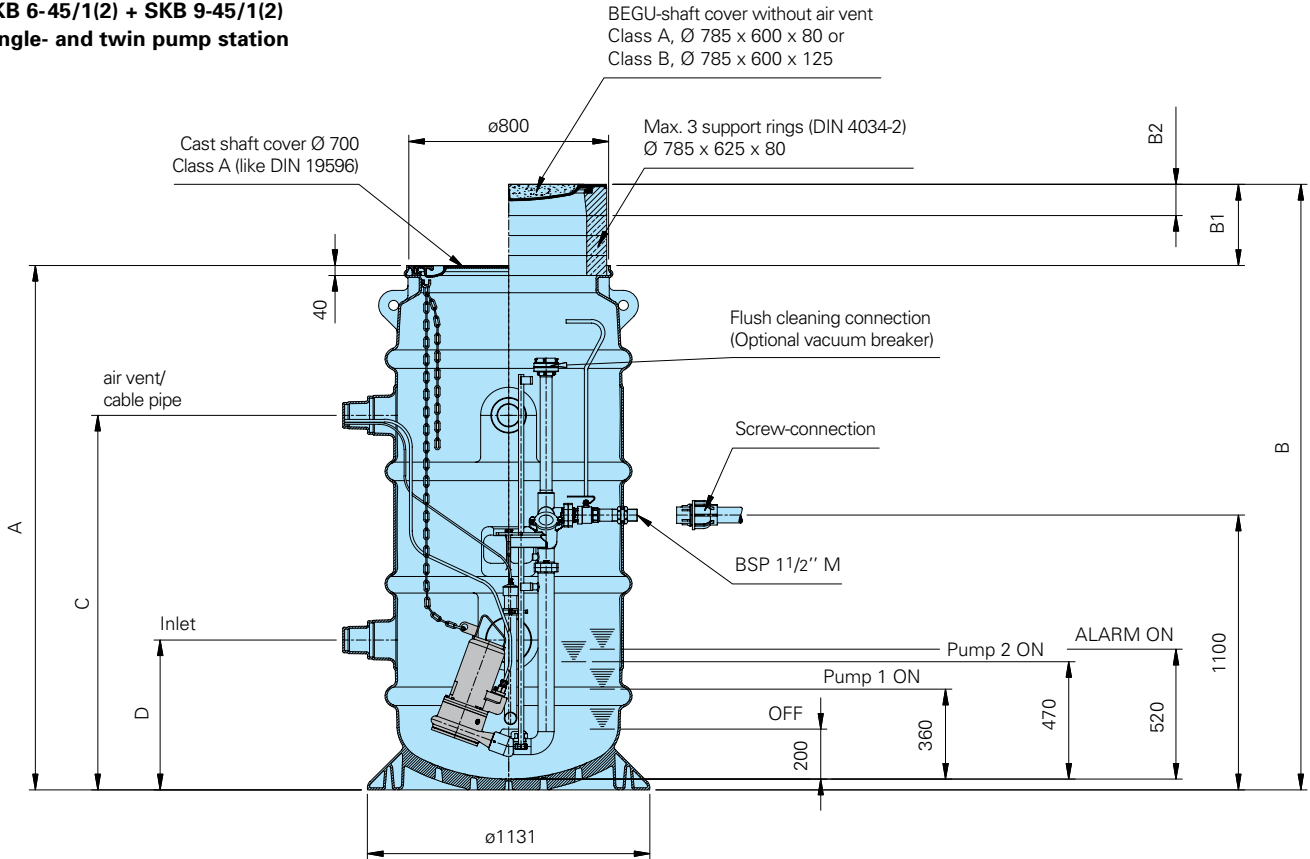

SKB 6-45/2 + SKB 9-45/2
Twin pump station

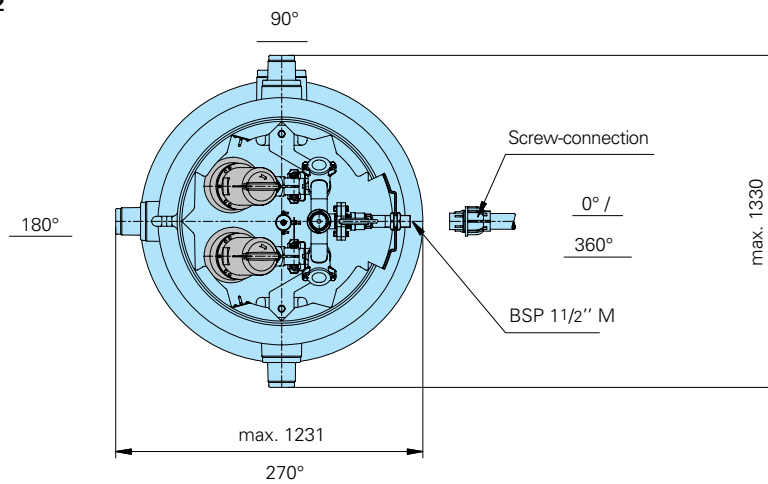

SKB 6-45/1 + SKB 9-45/1
Single pump station
(Dimensions same as twin pump station)

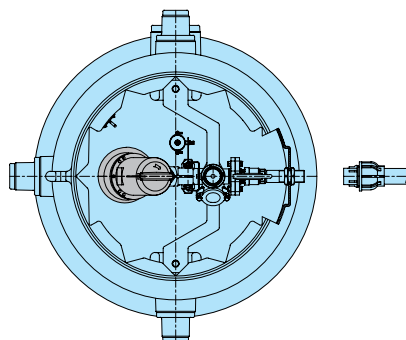

Dimensions

**SKB 6-45/1(2) + SKB 9-45/1(2)
Single- and twin pump station**

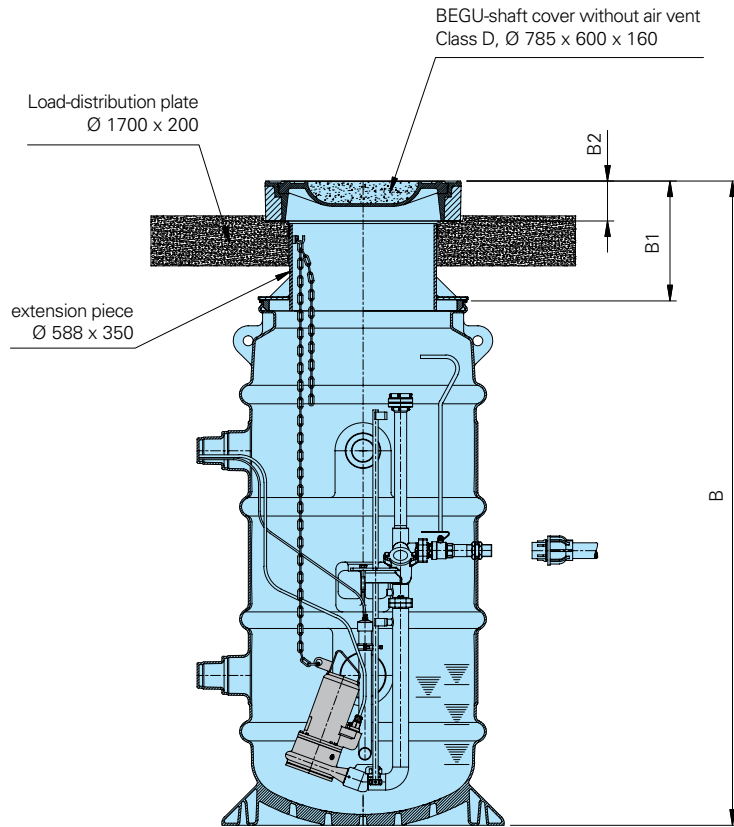

Tank	Cast cover Class A	BEGU-shaft cover ¹⁾ Class A			BEGU-shaft cover ¹⁾ Class B			BEGU-shaft cover ²⁾ Class D		
	A	B	B1	B2	B	B1	B2	B	B1	B2
SKB6-45/1+2	1650	1770-1930	120-280	80	1815-1975	165-325	125	2130-2230	480-580	160
SKB9-45/1+2	2100	2220-2380	120-280	80	2265-2425	165-325	125	2580-2680	480-580	160

Tank wall thickness min. 8mm

¹⁾ Total height (min. 1, max. 3 supporting rings 80 mm high)

²⁾ Total height (Installation with load-distribution plate)

Tank	Connections	C	D	90°	180°	270°
SKB6-45/1+2	air vent/ cable pipe	1050	–	–	DN100/150	
	Inlet	–	600	DN200	DN100/150	DN100/150
SKB9-45/1+2	air vent/ cable pipe	1500	–	DN100/150	DN100/150	
	Inlet	–	600	DN200	DN100/150	DN100/150

Connection –A-Ø: DN100-Ø109, DN150- Ø159, DN200- Ø198

Installation

SKB 9-45/1

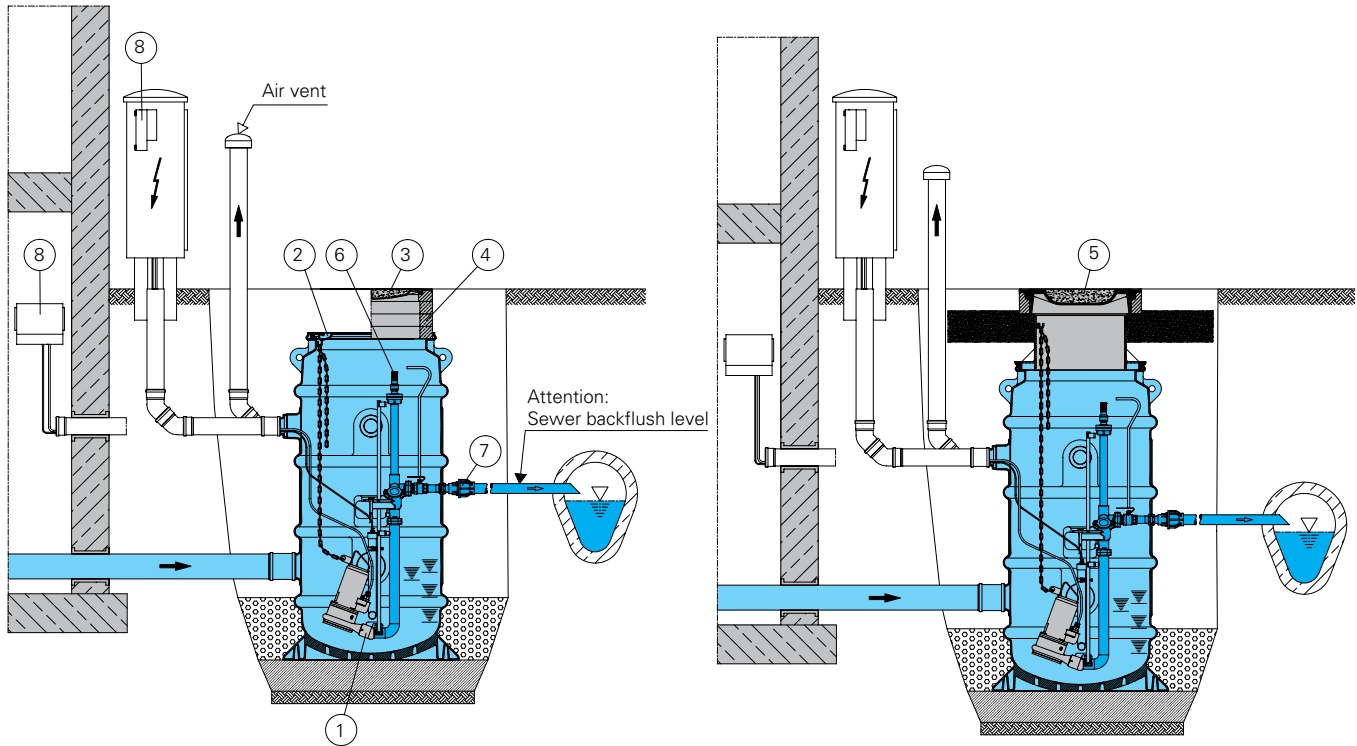

Accessories

① Pump coupling flange:
For connection the selected pump type to the coupling system.

Pump collecting flange	Pump type	Ref.-No.
BSP 2" M	TCV	7323233
BSP 2" F	TP 30, GRP	7323231
BSP 2 1/2" F	TP 50	7323941
BSP 2 1/2" M	TCM, TCV	7323943

Shaft cover

		Part.-No.
② Cast iron, Class A	ø800 mm	2804920
③ BEGU-cover (only for supporting ring)		
Class A	ø785x600x80 mm	2805005
Class B	ø785x600x125 mm	2805014
④ Supporting ring, concrete	ø785x625x80 mm	2805000
⑤ BEGU cover kit, class D with, load-distribution plate	ø1700x600 mm	8608050
⑥ Vacuum braker compl., stainless steel	BSP 1 1/2" / BSP 1"	7336624
⑦ Screw-connection for PE-HD discharge pipe	ø 50 x 4,6 mm / ø 63 x 5,8 mm	2109160 / 2109165

Control panel:

Electronic control panel with plastic housing IP 54. Manual-O-automatic switch. Pilot lights for operation, direction of rotation (3-phase models only), alarm and faults. Overload protection with contractor. Mainsoperated alarm with buzzer. Mains-independent alarm connector with battery charger for storage battery. Voltfree contact for remote signal. Pump motor overtemperature protection on pumps with integrated thermal sensors. Operation capacitor or start capacitor (for single-phase models only). Pneumatic level control with pressure tube, pressure switch and compressor. Twin pump station control panel additionally with autochangeover after each pump cycle, operation of second pump at high flow, automatic change to standby pump in case of pump failure.

⑧ Complete control panels
PS / HCON / HSKB see accessories

Control panels for
230 V / 1 Ph on request

Storage Battery 9.6 V for
mains independant alarm 1952214

Electronic seal control of
pump oil chamber with
alarm at the control panel see accessories

