



Process Equipment Catalog

Pumping Solutions for Process Industries



motralec

4 rue Lavoisier . ZA Lavoisier . 95223 HERBLAY CEDEX

Tel. : 01.39.97.65.10 / Fax. : 01.39.97.68.48

Demande de prix / e-mail : service-commercial@motralec.com

www.motralec.com

PROVEN QUALITY. LEADING TECHNOLOGY.

Contents

Air-Operated Double Diaphragm Pumps Model Overview 2
Pump Selection Key for Husky™ AODD Pumps..... 4
Husky 205 Plastic Pumps 7
Husky 307 Plastic Pumps 9
Husky 515 Plastic Pumps 12
Husky 716 Metal Pumps 15
Husky 1050 Plastic Pumps 18
Husky 1050 Metal Pumps 21
Husky 1590 Plastic Pumps 25
Husky 1590 Metal Pumps 28
Husky 2150 Plastic Pumps 31
Husky 2150 Metal Pumps 34
Husky 3300 Plastic Pumps 37
Husky 3300 Metal Pumps 41
Husky Transfer Pump Packages 44
Husky Transfer Pump and Agitator Packages..... 47
Husky Pump Accessories 48
EP Series Hose Pumps..... 53
Hydra-Clean® 61
CycleFlo™ and CycleFlo II 64
Fast-Flo® 1:1 66
Piston Pumps for Ink Applications 67
Surge Suppressors 71

Air-Operated Double Diaphragm Pumps

Model Overview

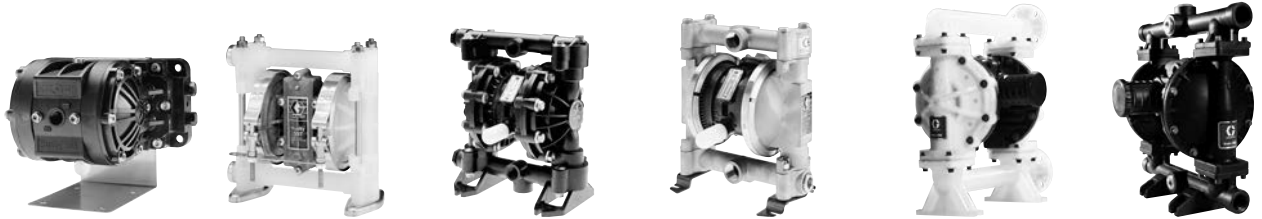

Model	Husky 205 Plastic	Husky 307 Plastic	Husky 515 Plastic	Husky 716 Metal	Husky 1050 Plastic	Husky 1050 Metal
Connection Size	6.3 mm (1/4 in)	9.4 mm (3/8 in)	12.7 mm (1/2 in) and 19.1 mm (3/4 in)	19.1 mm (3/4 in)	25.4 mm (1 in)	25.4 mm (1 in)
Thread Type	NPT or BSP	NPT or BSP	NPT or BSP	NPT or BSP	ANSI/DIN Flange	NPT or BSP
Air Valve	Standard and Remote	Standard	Standard and Remote	Standard and Remote	Standard, Smart and Remote	Standard, Smart and Remote
Maximum Flow Rate	19 l/min (5 gpm)	26 l/min (7 gpm)	57 l/min (15 gpm)	61 l/min (16 gpm)	189 l/min (50 gpm)	189 l/min (50 gpm)
Maximum Discharge Pressure	7.0 bar (0.7 MPa - 100 psi)	7.0 bar (0.7 MPa - 100 psi)	7.0 bar (0.7 MPa - 100 psi)	7.0 bar (0.7 MPa - 100 psi)	8.6 bar (0.9 MPa - 125 psi)	8.6 bar (0.9 MPa - 125 psi)
Materials of Construction Available	Polypropylene, PVDF, Acetal	Polypropylene, Acetal	Polypropylene, PVDF, Acetal	Aluminium, 316 Stainless Steel	Polypropylene, Conductive Poly, PVDF	Aluminium, 316 Stainless Steel, Hastelloy
Center Section Available	Polypropylene	Polypropylene	Polypropylene	Polypropylene	Polypropylene, Conductive Poly	Coated Aluminium, Polypropylene, Conductive Poly
Pump Weight	0.9 kg (2.0 lb) Polypropylene	2.2 kg (4.75 lb) Acetal	2.9 kg (6.5 lb) Polypropylene	3.9 kg (8.5 lb) Aluminium	8.2 kg (18 lb) Polypropylene	10.4 kg (23 lb) Aluminium
	1.1 kg (2.5 lb) Acetal	2.4 kg (5.2 lb) Polypropylene	3.5 kg (7.8 lb) Acetal	8.2 kg (18 lb) Stainless Steel	11.8 kg (26 lb) PVDF	16.5 - 18.6 kg (36.3 - 41 lb) Stainless Steel
	1.3 kg (2.8 lb) PVDF		3.9 kg (8.5 lb) PVDF			18.6 kg (41 lb) Hastelloy
Maximum Solids	1.5 mm (0.06 in)	1.6 mm (0.063 in)	2.5 mm (0.094 in)	2.5 mm (0.094 in)	3.2 mm (.125 in)	3.2 mm (.125 in)

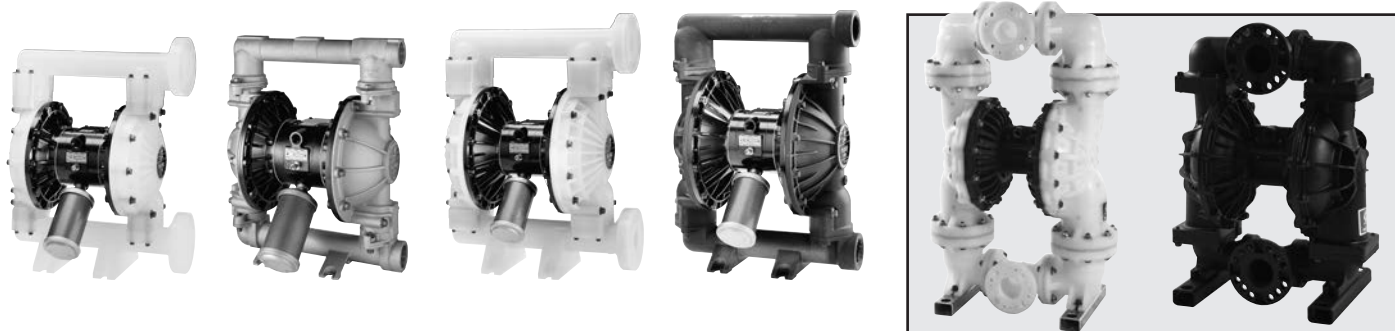

Husky 1590 Plastic	Husky 1590 Metal	Husky 2150 Plastic	Husky 2150 Metal	Husky 3300 Plastic	Husky 3300 Metal
38.1 mm (1-1/2 in)	38.1 mm (1-1/2 in)	50.8 mm (2 in)	50.8 mm (2 in)	76.2 mm (3 in)	76.2 mm (3 in)
ANSI Flange	NPT or BSP	ANSI Flange	NPT or BSP	DIN/ANSI	NPT and BSP DIN/ANSI (AL only)
Standard and Remote	Standard and Remote	Standard and Remote	Standard and Remote	Standard	Standard
379 l/min (100 gpm)	379 l/min (100 gpm)	568 l/min (150 gpm)	568 l/min (150 gpm)	1059 l/min (280 gpm)	1135 l/min (300 gpm)**
8.3 bar (0.8 MPa - 120 psi)	8.3 bar (0.8 MPa - 120 psi)	8.3 bar (0.8 MPa - 120 psi)	8.3 bar (0.8 MPa - 120 psi)	7 bar (0.7 MPa - 100 psi)	8.6 bar (0.9 MPa - 125 psi)
Polypropylene, PVDF	Aluminium, 316 Stainless Steel	Polypropylene, PVDF	Aluminium, 316 Stainless Steel, Ductile Iron	Polypropylene	Aluminum, 316 Stainless Steel
Coated Aluminium, 316 Stainless Steel	Coated Aluminium, 316 Stainless Steel	Coated Aluminium, 316 Stainless Steel	Coated Aluminium, 316 Stainless Steel	Polypropylene	Aluminum, Polypropylene* (*SST pump only)
16 kg (35 lb) Polypropylene	15.2 kg (33.5 lb) Aluminium	22 kg (49 lb) Polypropylene	26.3 kg (58 lb) Aluminium	90.7 kg (200 lb) Polypropylene	68 kg (150 lb) Aluminium
22 kg (49 lb) PVDF	40 kg (86 lb) Stainless Steel	31 kg (68 lb) PVDF	50.3 kg (111 lb) Stainless Steel		115.6 kg (255 lb) Stainless Steel
			59 kg (130 lb) Ductile Iron		
4.8 mm (0.188 in)	4.8 mm (0.188 in)	6.3 mm (0.25 in)	6.3 mm (0.25 in)	12.7 mm (0.5 in)	12.7 mm (0.5 in)
NEW! Husky 3300 3 inch Pump Family					

**Maximum flow rate using standard diaphragm at 8.6 bar (125 psi).

Pump Selection Key

Husky AODD Pumps

Pump Designation

Part numbers are located on ID tag on center section of all Husky diaphragm pumps.

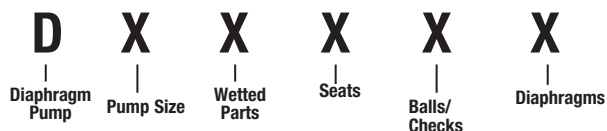

PUMP SIZE (AIR MOTOR TYPE AND MATERIAL)	WETTED PARTS	SEATS	BALLS	DIAPHRAGM
1 = 6.35 mm (1/4") Standard: polypropylene center section 2 = 6.35 mm (1/4") Remote: polypropylene center section 3 = 9.52 mm (3/8") Standard: Aluminium center section 5 = 12.7 mm (1/2") Standard: polypropylene center section 4 = 12.7 mm (1/2") Remote: polypropylene center section 5 = 19.05 mm (3/4") Standard: polypropylene center section 4 = 19.05 mm (3/4") Remote: polypropylene center section 25.4 mm (1") refer to Husky 1050 Selector Tool, page 5 B = 38.1 mm (1-1/2") Standard: Aluminium center section C = 38.1 mm (1-1/2") Remote: Aluminium center section T = 38.1 mm (1-1/2") Standard: stainless steel center section U = 38.1 mm (1-1/2") Remote: stainless steel center section F = 50.8 mm (2") Standard: Aluminium center section G = 50.8 mm (2") Remote: Aluminium center section V = 50.8 mm (2") Standard: stainless steel center section 76.2 mm (3") refer to Husky Selector Tool, page 5	1 = Acetal (npt) 2 = Poly (npt) 3 = Aluminium (npt) 4 = Stainless Steel (npt) 5 = PVDF (npt) 6 = Ductile Iron (npt) A = Acetal * (bsp) B = Poly * (bsp) C = Aluminium (bsp) D = Stainless Steel (bsp) E = PVDF (bsp) F = Ductile Iron (bsp) H = 2 npt Alum Extended G = 2 bsp Alum Extended	2 = Acetal 3 = Stainless Steel 4 = Hardened SST 5 = TPE 6 = Santoprene 7 = Buna N 8 = Fluoroelastomer 9 = Polypropylene A = PVDF G = Geolast B = SST with viton seal C = Santoprene with viton seal	1 = PTFE 2 = Acetal 3 = Stainless Steel 4 = Hardened SST 5 = TPE 6 = Santoprene 7 = Buna N 8 = Fluoroelastomer 9 = Polypropylene A = PVDF G = Geolast	1 = PTFE 5 = TPE 6 = Santoprene 7 = Buna N 8 = Fluoroelastomer G = Geolast

* = BSP plastic in 12.7 mm (1/2") pumps

≥1" Plastic pumps flange connections

3" Aluminium pumps flange/npt (f) combination connections

Note: Above matrix is all possible combinations. All combinations may not be available. See specific pump listings for available combinations.

Diaphragm Pump Kit Designation

When selecting a kit, use the same code numbers as for the pumps regarding pump size, seat, ball/checks and diaphragm.

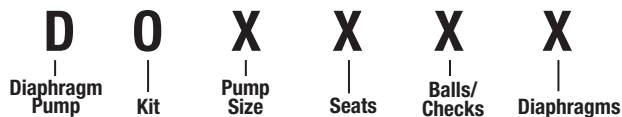

Pump Size	Seats	Balls/Checks	Diaphragm
1 = 6.35 mm (1/4") 3 = 9.52 mm (3/8") 5 = 12.7 mm (1/2") and 19.05 mm (3/4") 25.4 mm (1") refer to Husky 1050 Selector Tool, page 5 B = 38.1 mm (1-1/2") metal pump C = 38.1 mm (1-1/2") plastic pump F = 50.8 mm (2") metal pump G = 50.8 mm (2") plastic pump K = 76.2 mm (3")	0 = No seat 2 = Acetal 3 = Stainless Steel 4 = Hardened SST 5 = TPE 6 = Santoprene 7 = Buna N 8 = Fluoroelastomer 9 = Poly A = PVDF B = SST with viton seal C = Santoprene with viton seal G = Geolast	1 = PTFE 2 = Acetal 3 = Stainless Steel 4 = Hardened SST 5 = TPE 6 = Santoprene 7 = Buna-N 8 = Fluoroelastomer 9 = Poly A = PVDF G = Geolast 0 = No Balls/Checks	1 = PTFE 5 = TPE 6 = Santoprene 7 = Buna-N 8 = Fluoroelastomer G = Geolast 0 = No Diaphragm

Husky 1050 & 3300 Selector Tool

Find the Right Pump for your Application

To order a Husky 1050 or a Husky 3300, use the online selector tool at www.graco.com or contact your distributor.

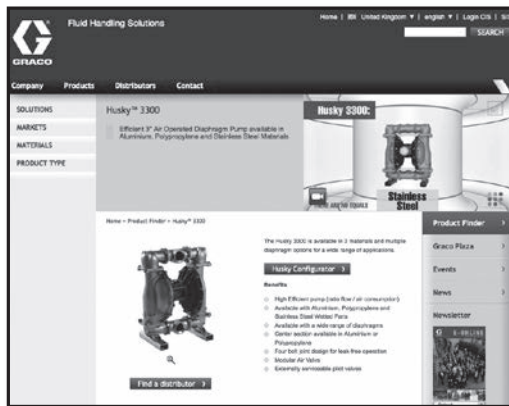

Example of Product Selector Tool on www.graco.com/process.

Wetted Parts Material Options

Acetal *Material used for seats, balls & wetted body parts*

- Wide range of solvent resistance
- Withstands extreme fatigue
- Good level of abrasion resistance
- Groundable for use with flammables
- Not for use with acids or bases

Aluminium *Material used for air motor & wetted body parts*

- Medium corrosion and abrasion resistance
- Not for use with halogenated hydrocarbons

Ductile Iron *Material used for wetted body parts*

- High abrasion resistance

Hardened SST *Material used for seats and balls*

- Moderate chemical resistance
- Good abrasion resistance
- Abrasion resistant balls and seats

PVDF *Material used for wetted body parts & seats*

- Strong chemical resistance: acids and bases
- Good abrasion resistance
- High temperature resistance

Polypropylene *Material used for air motor, wetted body parts, seats & balls*

- Wide chemical compatibility
- General purpose
- Inexpensive alternative

Stainless Steel *Material used for air motor, wetted body parts, and seats and balls*

- High level of corrosion and abrasion resistance
- Passivated for use with waterbase coatings

Buna-N *Material used for seats, balls and diaphragms*

- Good for petroleum-based fluids
- Not for use with strong solvents or chemicals
- Food grade

Geolast *Material used for seats, balls & diaphragms*

- Good abrasion resistance
- Same chemical compatibility as Buna-N and TPE

TPE *Material used for seats, balls & diaphragms*

- Good abrasion resistance
- Often substituted for Buna-N

Santoprene® *Material used for seats, balls & diaphragms*

- Good abrasion and chemical resistance
- Not for use with solvents or hydrocarbons
- Often substituted for EPDM or EPR
- Food grade*

PTFE *Material used for balls & diaphragms*

- Excellent when used with solvents
- Poor abrasion resistance
- Widest chemical compatibility with fluids
- Food grade

Fluoroelastomer *Material used for seats, balls & diaphragms*

- High level of corrosion resistance with acids
- Resists unleaded fuels
- Food grade

Hastelloy *Material used for wetted body parts*

- Good resistance to aggressive chemicals and in corrosive environments
- Compatible with high temperature fluids

*Not recommended for use with Husky 1050 diaphragms

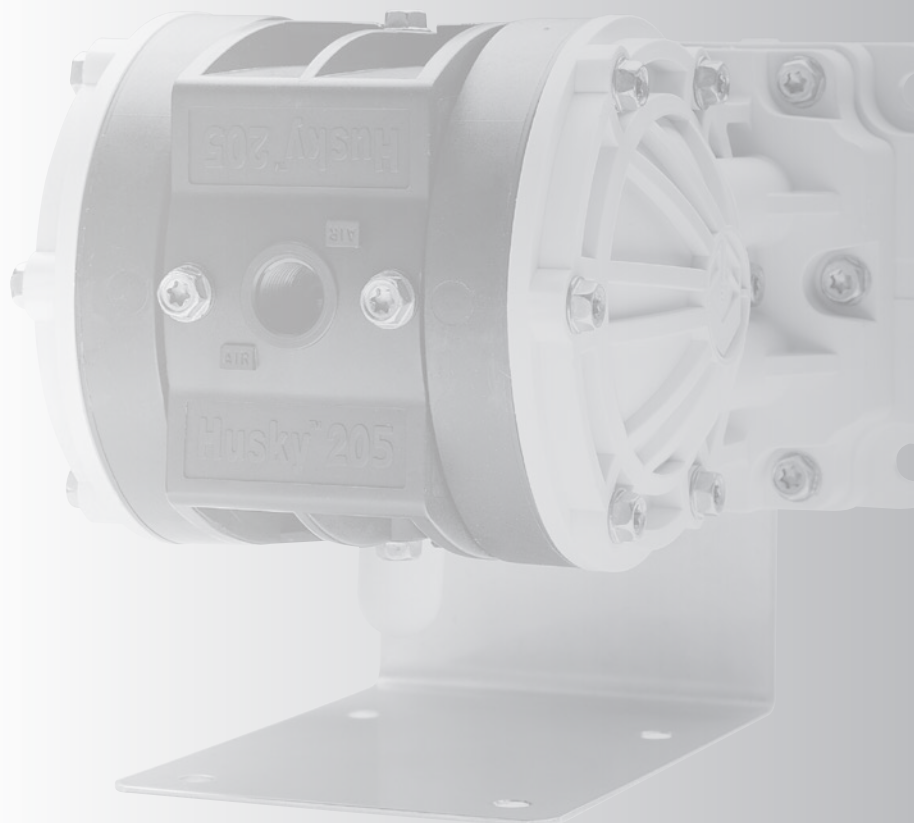
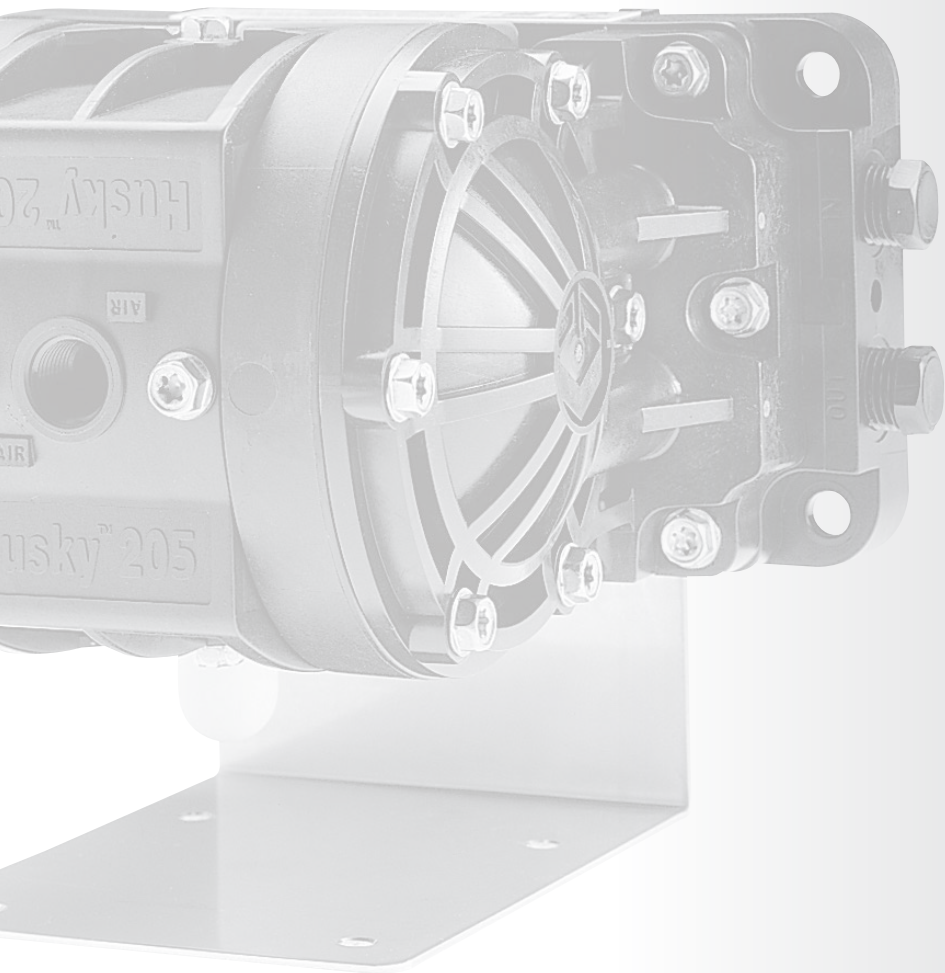

Husky 205 Plastic Pumps

Air-Operated Double Diaphragm

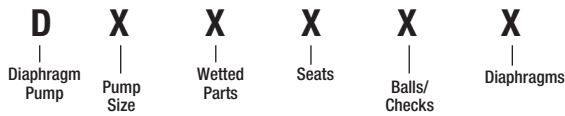

PUMP SIZE (AIR MOTOR TYPE AND MATERIAL)	WETTED PARTS	SEATS	CHECK VALVES	DIAPHRAGM
1 = 6.35 mm (1/4") Standard: polypropylene center section 2 = 6.35 mm (1/4") Remote: polypropylene center section	1 = Acetal (npt) 2 = Poly (npt) 5 = PVDF (npt)	0 = No Seats	2 = Acetal 9 = Polypropylene A = PVDF	1 = PTFE 6 = Santoprene

Popular Models

Material	Part Number (NPT Ported)		Part Number (BSP Ported)		Materials for Check Valves	Materials for Diaphragms	Fluid Kit	Air Kit	Air Control**
	Standard Air Valve	Remote* Air Valve	Standard Air Valve	Remote* Air Valve					
Acetal	D11021	D21021	D11021	D21021	Acetal	PTFE	D01021	238853	246946
	D11026	D21026	D11026	D21026	Acetal	Santoprene	D01026	238853	246946
PVDF	D150A1	D250A1	D150A1	D250A1	PVDF	PTFE	D010A1	238853	246946
	D150A6	D250A6	D150A6	D250A6	PVDF	Santoprene	D010A6	238853	246946
Polypropylene	D12091	D22091	D12091	D22091	Polypropylene	PTFE	D01091	238853	246946
	D12096	D22096	D12096	D22096	Polypropylene	Santoprene	D01096	238853	246946

* Requires CycleFlo or external valve control

** Air control includes air regulator and filter with gauge



Husky 205 Plastic Pumps	Acetal	Polypropylene	PVDF
Maximum fluid working pressure	7 bar (0.7 MPa - 100 psi)	7 bar (0.7 MPa - 100 psi)	7 bar (0.7 MPa - 100 psi)
Maximum free flow delivery*	18.9 l/min (5.0 gpm)	18.9 l/min (5.0 gpm)	18.9 l/min (5.0 gpm)
Maximum pump speed	250 cpm	250 cpm	250 cpm
Displacement per cycle**	0.045 liter (0.012 gallon)	0.045 liter (0.012 gallon)	0.045 liter (0.012 gallon)
Maximum suction lift (D12096)	3 m (10 ft) dry	3 m (10 ft) dry	3 m (10 ft) dry
Maximum size pumpable solids	1.5 mm (0.06 in)	1.5 mm (0.06 in)	1.5 mm (0.06 in)
Maximum operating temperature***	82°C (180°F)	82°C (180°F)	82°C (180°F)
Maximum diaphragm operating temperature***			
PTFE	104.4°C (220°F)	104.4°C (220°F)	104.4°C (220°F)
Santoprene	82.2°C (180°F)	82.2°C (180°F)	82.2°C (180°F)
Typical sound level at 4.9 bar (0.49 MPa - 70 psi) air @ 125 cpm	70 dBA	70 dBA	70 dBA
Maximum air consumption	0.252 m ³ /min (9.0 scfm)	0.252 m ³ /min (9.0 scfm)	0.252 m ³ /min (9.0 scfm)
Air pressure operating range	1.4 to 7 bar (0.14 to 0.7 MPa - 20 to 100 psi)	1.4 to 7 bar (0.14 to 0.7 MPa - 20 to 100 psi)	1.4 to 7 bar (0.14 to 0.7 MPa - 20 to 100 psi)
Air inlet size	1/4 npt(f)	1/4 npt(f)	1/4 npt(f)
Air exhaust port size	1/4 npt(f)	1/4 npt(f)	1/4 npt(f)
Fluid inlet & outlet size****	1/4 npt(f)	1/4 npt(f)	1/4 npt(f)
Weight	1.1 kg (2.5 lb)	0.9 kg (2.0 lb)	1.3 kg (2.8 lb)
Wetted parts (in addition to ball, seat and diaphragm materials – which may vary by pump)	Acetal with Stainless Steel fibers, PTFE, Acetal, Santoprene	Glass-filled Polypropylene, Santoprene, PTFE, Polypropylene	PVDF, PTFE, Santoprene
Instruction manual	308652	308652	308652

** Displacement per cycle may vary based on suction condition, discharge head, air pressure and fluid type

*** Actual pump performance may be affected by prolonged usage at temperature

**** Hybrid thread allows for either 1/4 npt or 1/4 bspt fitting

Husky 205 Plastic Pumps

Performance Charts

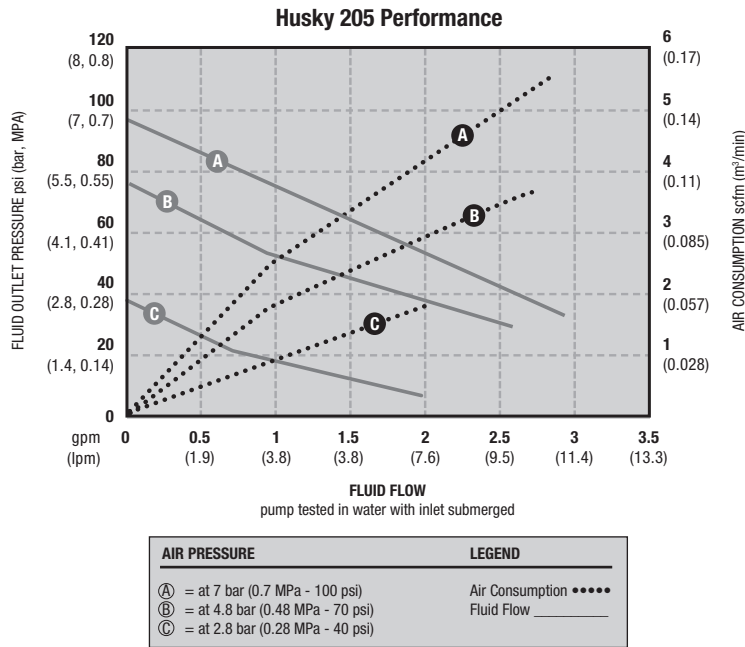

Dimensions

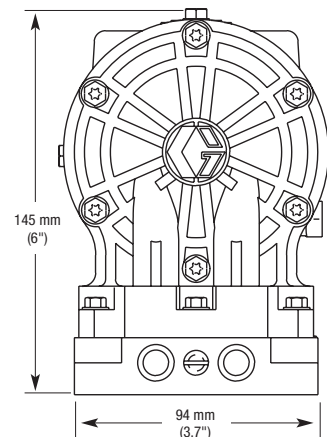
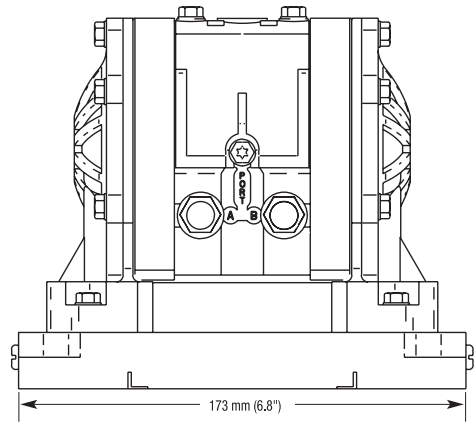

Typical System Drawings

Husky 205 Wall-Mount with CycleFlo

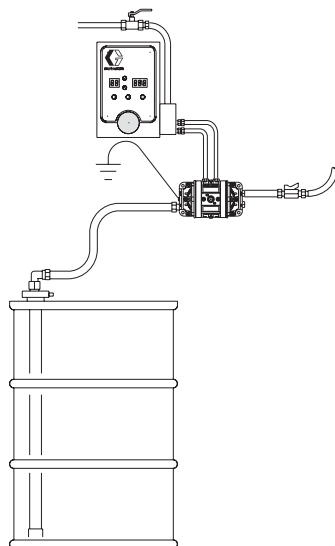

Husky 307 Plastic Pumps

Air-Operated Double Diaphragm

D | Diaphragm Pump
X | Pump Size
X | Wetted Parts
X | Seats
X | Balls/Checks
X | Diaphragms

PUMP SIZE (AIR MOTOR TYPE AND MATERIAL)	WETTED PARTS	SEATS	BALLS	DIAPHRAGM
3 = 9.52 mm (3/8") Standard: polypropylene center section	1 = Acetal (npt) 2 = Poly (npt) A = Acetal * (bsp) B = Poly * (bsp)	2 = Acetal 3 = Stainless Steel 9 = Polypropylene	1 = PTFE 3 = SST 5 = TPE 6 = Santoprene 7 = Buna N	1 = PTFE 5 = TPE 6 = Santoprene 7 = Buna N

Popular Models

Material	Part Number (NPT Ported)		Part Number (BSP Ported)		Materials for Seats	Materials for Balls	Materials for Diaphragms	Fluid Kit	Air Kit	Air Control*
	Standard Air Valve	Remote Air Valve	Standard Air Valve	Remote Air Valve						
Acetal	D31211	-	D3A211	-	Acetal	PTFE	PTFE	D03211	239952	246946
	D31255	-	D3A255	-	Acetal	TPE	TPE	D03255	239952	246946
	D31277	-	D3A277	-	Acetal	Buna	Buna	D03277	239952	246946
	D31311	-	D3A311	-	Stainless Steel	PTFE	PTFE	D03311	239952	246946
Polypropylene	D32211	-	D3B211	-	Acetal	PTFE	PTFE	D03211	239952	246946
	D32255	-	D3B255	-	Acetal	TPE	TPE	D03255	239952	246946
	D32277	-	D3B277	-	Acetal	Buna	Buna	D03277	239952	246946
	D32311	-	D3B311	-	Stainless Steel	PTFE	PTFE	D03311	239952	246946
	D32366	-	D3B366	-	Stainless Steel	Santoprene	Santoprene	D03366	239952	246946
	D32911	-	D3B911	-	Polypropylene	PTFE	PTFE	D03911	239952	246946
	D32955	-	D3B955	-	Polypropylene	TPE	TPE	D03955	239952	246946
	D32966	-	D3B966	-	Polypropylene	Santoprene	Santoprene	D03966	239952	246946
	D32977	-	D3B977	-	Polypropylene	Buna	Buna	D03977	239952	246946

* Air control includes air regulator and filter with gauge

- = not available

Husky 307 Plastic Pumps



Technical Specifications

Husky 307 Plastic Pumps	Acetal	Polypropylene
Maximum fluid working pressure	7 bar (0.7 MPa-100 psi)	7 bar (0.7 MPa-100 psi)
Maximum free flow delivery*	26.5 l/min (7.0 gpm)	26.5 l/min (7.0 gpm)
Maximum pump speed	330 cpm	330 cpm
Displacement per cycle**	0.076 liter (0.02 gallon)	0.076 liter (0.02 gallon)
Maximum suction lift (D31255)	3.7 m (12 ft) dry	3.7 m (12 ft) dry
Maximum size pumpable solids	1.5 mm (0.06 in)	1.5 mm (0.06 in)
Maximum operating temperature***	65.5°C (150°F)	65.5°C (150°F)
Maximum diaphragm operating temperature***		
PTFE	104.4°C (220°F)	104.4°C (220°F)
Santoprene	82.2°C (180°F)	82.2°C (180°F)
Buna-N	82.2°C (180°F)	82.2°C (180°F)
TPE	65.5°C (150°F)	65.5°C (150°F)
Typical sound level at 3.5 bar (0.35 MPa-50 psi) air @ 50 cpm	75 dBa	75 dBa
Maximum air consumption	0.17 m ³ /min (6 scfm)	0.17 m ³ /min (6 scfm)
Air pressure operating range	1.4 to 8.4 bar (0.14 to 0.84 MPa-20 to 100 psi)	1.4 to 8.4 bar (0.14 to 0.84 MPa-20 to 100 psi)
Air inlet size	1/4 npt(f) or bspt(f)	1/4 npt(f) or bspt(f)
Fluid inlet & outlet size	3/8 npt(f)	3/8 npt(f)
Weight	2.4 kg (5.2 lb)	2.2 kg (4.75 lb)
Wetted parts (in addition to ball, seat and diaphragm materials—which may vary by pump)	Acetal with Stainless Steel fibers, PTFE	Polypropylene, PTFE
Instruction manual	308553	308553

*Flow rates are with muffler and do not vary based on diaphragm material

**Displacement per cycle may vary based on suction condition, discharge head, air pressure and fluid type

***Actual pump performance may be affected by prolonged usage at temperature

Performance Chart

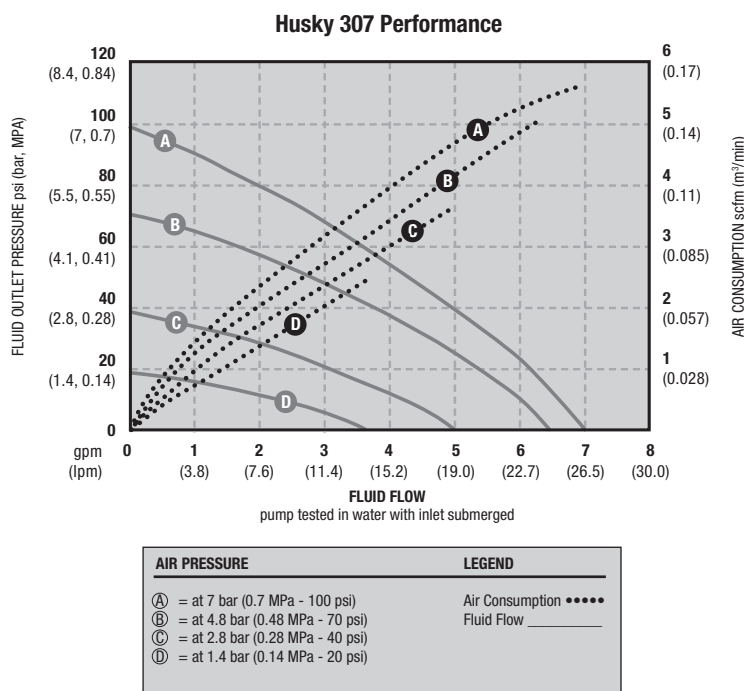

Husky 307 Plastic Pumps

Dimensions

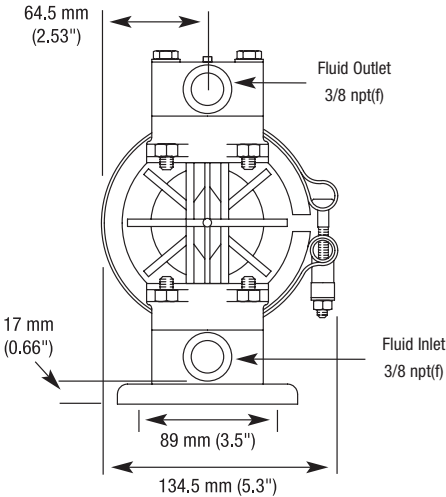
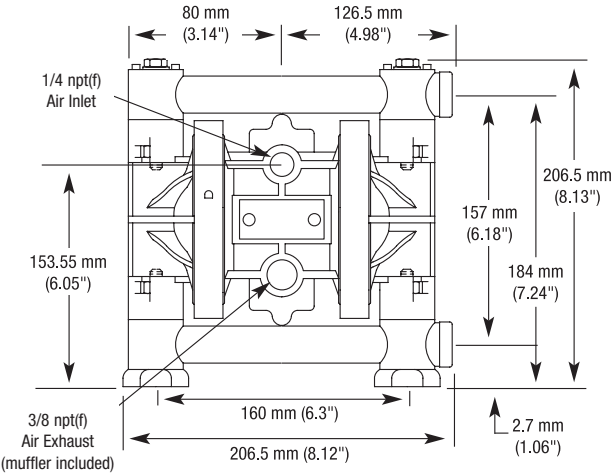

Typical System Drawings

Husky 307 Wall-Mount with Siphon Feed

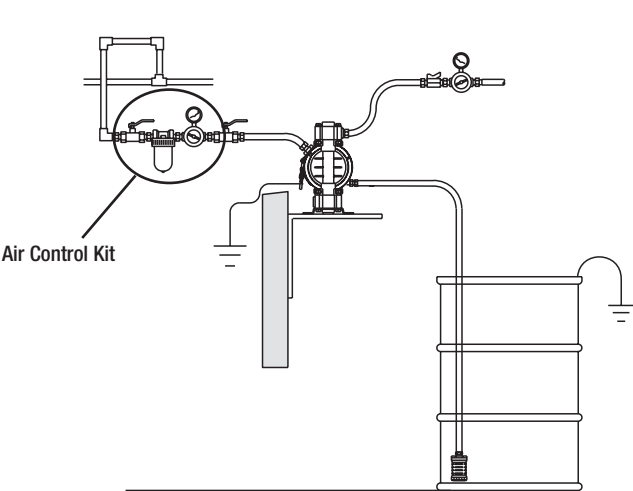

Husky 307 Drum-Mount with Siphon Feed

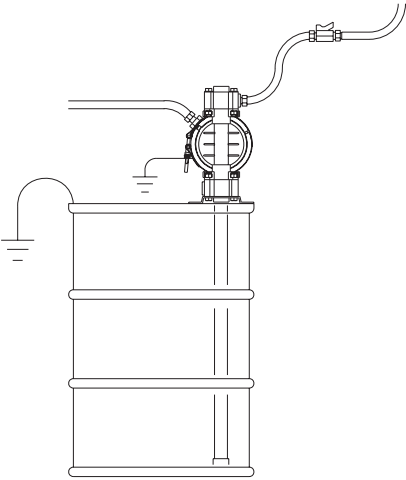

Husky 515 Plastic Pumps

Air-Operated Double Diaphragm

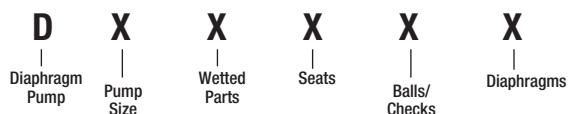

PUMP SIZE (AIR MOTOR TYPE AND MATERIAL)	WETTED PARTS	SEATS	BALLS	DIAPHRAGM
5 = 1/2" center (12.7 mm) or 3/4" ends (19.05) Standard: polypropylene center section 4 = 1/2" center (12.7 mm) or 3/4" ends (19.05) Remote: polypropylene center section	1 = Acetal (npt) 2 = Poly (npt) 5 = PVDF (npt) A = Acetal * (bsp) B = Poly * (bsp) E = PVDF (bsp)	2 = Acetal 3 = Stainless Steel 9 = Polypropylene A = PVDF D = Urethane Duckbill	1 = PTFE 3 = Stainless Steel 5 = TPE 6 = Santoprene 7 = Buna N 8 = Fluoroelastomer 0 = Duckbill	1 = PTFE 5 = TPE 6 = Santoprene 7 = Buna N 8 = Fluoroelastomer

* = BSP plastic in 12.7 mm (1/2") pumps

Popular Models

Material	Part Number (NPT Ported)		Part Number (BSP Ported)		Materials for Seats	Materials for Balls	Materials for Diaphragms	Fluid Kit	Air Kit	Air Control**
	Standard Air Valve	Remote* Air Valve	Standard Air Valve	Remote* Air Valve						
Acetal	D51211	D41211	D5A211	D4A211	Acetal	PTFE	PTFE	D05211	241657	246946
	D51255	D41255	D5A255	D4A255	Acetal	TPE	TPE	D05255	241657	246946
	D51277	D41277	D5A277	D4A277	Acetal	Buna	Buna	D05277	241657	246946
	D51311	D41311	D5A311	D4A311	Stainless Steel	PTFE	PTFE	D05311	241657	246946
	D51331	D41331	D5A331	D4A331	Stainless Steel	Stainless Steel	PTFE	D05331	241657	246946
	D51D05	D41D05	D5AD05	D4AD05	Duckbill		TPE	D05D05	241657	246946
	D51D06	D41D06	D5AD06	D4AD06	Duckbill		Santoprene	D05D06	241657	246946
	D51D07	D41D07	D5AD07	D4AD07	Duckbill		Buna	D05D07	241657	246946
Polypropylene	D52211	D42211	D5B211	D4B211	Acetal	PTFE	PTFE	D05211	241657	246946
	D52277	D42277	D5B277	D4B277	Acetal	Buna	Buna	D05277	241657	246946
	D52311	D42311	D5B311	D4B311	Stainless Steel	PTFE	PTFE	D05311	241657	246946
	D52331	D42331	D5B331	D4B331	Stainless Steel	Stainless Steel	PTFE	D05331	241657	246946
	D52336	D42336	D5B336	D4B336	Stainless Steel	Stainless Steel	Santoprene	D05336	241657	246946
	D52911	D42911	D5B911	D4B911	Polypropylene	PTFE	PTFE	D05911	241657	246946
	D52955	D42955	D5B955	D4B955	Polypropylene	TPE	TPE	D05955	241657	246946
	D52966	D42966	D5B966	D4B966	Polypropylene	Santoprene	Santoprene	D05966	241657	246946
	D52977	D42977	D5B977	D4B977	Polypropylene	Buna	Buna	D05977	241657	246946
	D52988	D42988	D5B988	D4B988	Polypropylene	Fluoroelastomer	Fluoroelastomer	D05988	241657	246946
	D52D05	D42D05	D5BD05	D4BD05	Duckbill		TPE	D05D05	241657	246946
	D52D06	D42D06	D5BD06	D4BD06	Duckbill		Santoprene	D05D06	241657	246946
D52D07	D42D07	D5BD07	D4BD07	Duckbill		Buna	D05D07	241657	246946	
PVDF	D55A11	D45A11	D5EA11	D4EA11	PVDF	PTFE	PTFE	D05A11	241657	246946
	D55A88	D45A88	D5EA88	D4EA88	PVDF	Fluoroelastomer	Fluoroelastomer	D05A88	241657	246946

*Required Cycleflo or external valve control

** Air control includes air regulator and filter with gauge

Husky 515 Plastic Pumps



Technical Specifications

Husky 515 Plastic Pumps	Acetal	Polypropylene	PVDF
Maximum fluid working pressure	7 bar (0.7 MPa - 100 psi)	7 bar (0.7 MPa - 100 psi)	7 bar (0.7 MPa - 100 psi)
Maximum free flow delivery*	57 l/min (15 gpm)	57 l/min (15 gpm)	57 l/min (15 gpm)
Maximum pump speed	400 cpm	400 cpm	400 cpm
Displacement per cycle**	0.15 liter (0.04 gallon)	0.15 liter (0.04 gallon)	0.15 liter (0.04 gallon)
Maximum suction lift	4.5 m (15 ft) dry	4.5 m (15 ft) dry	4.5 m (15 ft) dry
Maximum size pumpable solids	2.5 mm (0.09 in)	2.5 mm (0.09 in)	2.5 mm (0.09 in)
Maximum operating temperature***	82°C (180°F)	66°C (150°F)	66°C (150°F)
Maximum diaphragm operating temperature***			
PTFE	104.4°C (220°F)	104.4°C (220°F)	104.4°C (220°F)
Santoprene	82.2°C (180°F)	82.2°C (180°F)	82.2°C (180°F)
Buna-N	82.2°C (180°F)	82.2°C (180°F)	82.2°C (180°F)
TPE	65.5°C (150°F)	65.5°C (150°F)	65.5°C (150°F)
Fluoroelastomer	121.1°C (250°F)	121.1°C (250°F)	121.1°C (250°F)
Typical sound level at 4.9 bar (0.49 MPa - 70 psi) air @ 125 cpm	74 dBa	74 dBa	74 dBa
Maximum air consumption	0.672 m ³ /min (28 scfm)	0.672 m ³ /min (28 scfm)	0.672 m ³ /min (28 scfm)
Air pressure operating range	2.1 to 7 bar (0.21 to 0.7 MPa - 30 to 100 psi)	2.1 to 7 bar (0.21 to 0.7 MPa - 30 to 100 psi)	2.1 to 7 bar (0.21 to 0.7 MPa - 30 to 100 psi)
Air inlet size	1/4 npt(f)	1/4 npt(f)	1/4 npt(f)
Air exhaust port size	3/8 npt(f)	3/8 npt(f)	3/8 npt(f)
Fluid inlet & outlet size****	1/2 npt(f) or bspt(f)	1/2 npt(f) or bspt(f)	1/2 npt(f) or bspt(f)
Weight	3.5 kg (7.8 lb)	2.9 kg (6.5 lb)	3.9 kg (8.5 lb)
Wetted parts (in addition to ball, seat and diaphragm materials—which may vary by pump)	Groundable Acetal, PTFE, SST	Polypropylene, PTFE, SST	PVDF, PTFE
Instruction manual	308981	308981	308981

*Flow rates are with muffler and do not vary based on diaphragm material. **Displacement per cycle may vary based on suction condition, discharge head, air pressure and fluid type
 Actual pump performance may be affected by prolonged usage at temperature. *Hybrid thread allows for either 1/4 npt or 1/4 bspt fitting

Performance Charts

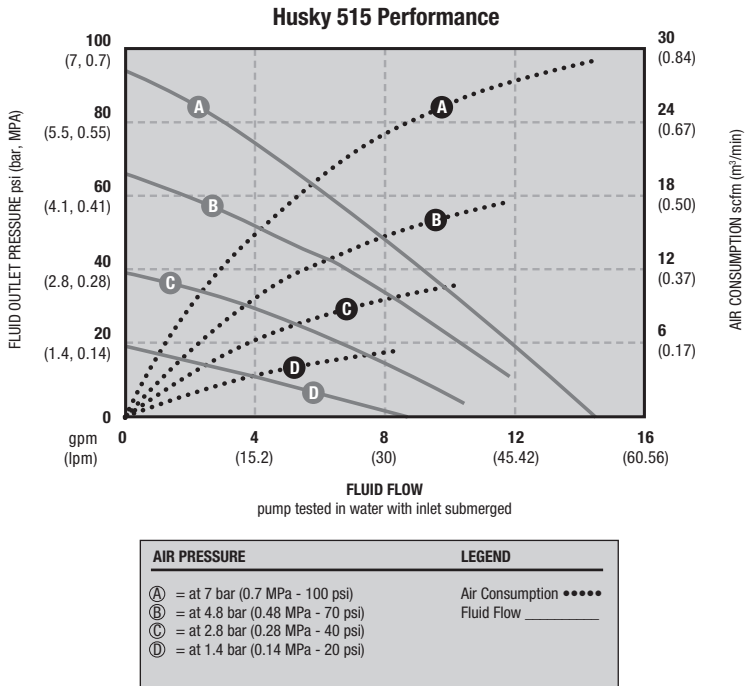

Husky 515 Plastic Pumps

Dimensions

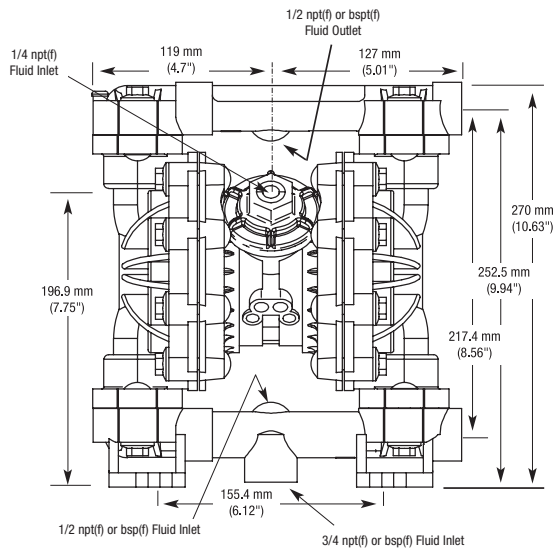

Typical System Drawings

Husky 515 Wall-Mount with Drum Feed

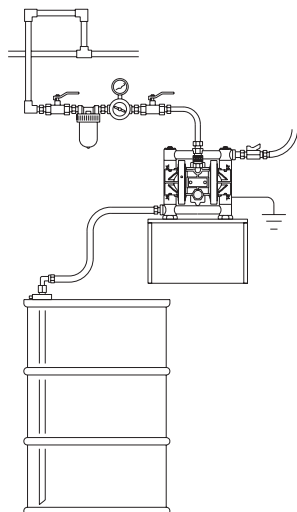

Husky 515 Drum-Mount with Siphon Feed

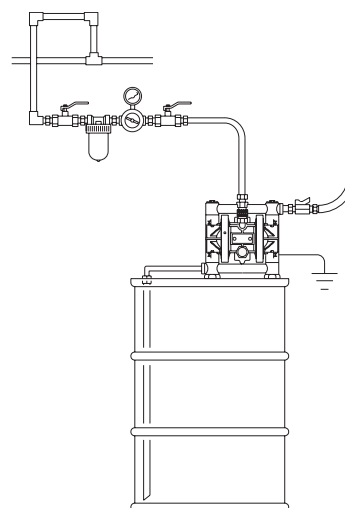

Husky 716 Metal Pumps

Air-Operated Double Diaphragm

D Diaphragm Pump
X Pump Size
X Wetted Parts
X Seats
X Balls/Checks
X Diaphragms

PUMP SIZE (AIR MOTOR TYPE AND MATERIAL)	WETTED PARTS	SEATS	BALLS	DIAPHRAGM
5 = 19.05 mm (3/4") Standard: polypropylene center section	3 = Aluminium (npt)	2 = Acetal	1 = PTFE	1 = PTFE
4 = 19.05 mm (3/4") Remote: polypropylene center section	4 = Stainless Steel (npt)	3 = Stainless Steel	3 = Stainless Steel	5 = TPE
		9 = Polypropylene	5 = TPE	6 = Santoprene
	C = Aluminium (bsp)	A = PVDF	6 = Santoprene	7 = Buna N
	D = Stainless Steel (bsp)	D = Duckbill	7 = Buna N	8 = Fluoroelastomer
			8 = Fluoroelastomer	

Popular Models

Material	Part Number (NPT Ported)		Part Number (BSP Ported)		Materials for Seats	Materials for Balls	Materials for Diaphragms	Fluid Kit	Air Kit	Air Control**
	Standard Air Valve	Remote* Air Valve	Standard Air Valve	Remote* Air Valve						
Aluminium	D53211	D43211	D5C211	D4C211	Acetal	PTFE	PTFE	D05211	241657	246946
	D53255	D43255	D5C255	D4C255	Acetal	TPE	TPE	D05255	241657	246946
	D53277	D43277	D5C277	D4C277	Acetal	Buna	Buna	D05277	241657	246946
	D53288	D43288	D5C288	D4C288	Acetal	Fluoroelastomer	Fluoroelastomer	D05288	241657	246946
	D53311	D43311	D5C311	D4C311	Stainless Steel	PTFE	PTFE	D05311	241657	246946
	D53331	D43331	D5C331	D4C331	Stainless Steel	Stainless Steel	PTFE	D05331	241657	246946
	D53355	D43355	D5C355	D4C355	Stainless Steel	TPE	TPE	D05355	241657	246946
	D53366	D43366	D5C366	D4C366	Stainless Steel	Santoprene	Santoprene	D05366	241657	246946
	D53377	D43377	D5C377	D4C377	Stainless Steel	Buna	Buna	D05377	241657	246946
	D53388	D43388	D5C388	D4C388	Stainless Steel	Fluoroelastomer	Fluoroelastomer	D05388	241657	246946
	D53911	D43911	D5C911	D4C911	Polypropylene	Polypropylene	Polypropylene	D05911	241657	246946
	D53955	D43955	D5C955	D4C955	Polypropylene	TPE	TPE	D05955	241657	246946
	D53966	D43966	D5C966	D4C966	Polypropylene	Santoprene	Santoprene	D05966	241657	246946
	D53977	D43977	D5C977	D4C977	Polypropylene	Buna	Buna	D05977	241657	246946
	D53D05	D43D05	D5CD05	D4CD05		Duckbill	TPE	D05D05	241657	246946
D53D06	D43D06	D5CD06	D4CD06		Duckbill	Santoprene	D05D06	241657	246946	
D53D07	D43D07	D5CD07	D4CD07		Duckbill	Buna	D05D07	241657	246946	
Stainless Steel	D54211	D44211	D5D211	D4D211	Acetal	PTFE	PTFE	D05211	241657	246946
	D54311	D44311	D5D311	D4D311	Stainless Steel	PTFE	PTFE	D05311	241657	246946
	D54331	D44331	D5D331	D4D331	Stainless Steel	Stainless Steel	PTFE	D05331	241657	246946
	D54335	D44335	D5D335	D4D335	Stainless Steel	Stainless Steel	TPE	D05335	241657	246946
	D54336	D44336	D5D336	D4D336	Stainless Steel	Stainless Steel	Santoprene	D05336	241657	246946
	D54355	D44355	D5D355	D4D355	Stainless Steel	TPE	TPE	D05355	241657	246946
	D54366	D44366	D5D366	D4D366	Stainless Steel	Santoprene	Santoprene	D05366	241657	246946
	D54377	D44377	D5D377	D4D377	Stainless Steel	Buna	Buna	D05377	241657	246946
	D54388	D44388	D5D388	D4D388	Stainless Steel	Fluoroelastomer	Fluoroelastomer	D05388	241657	246946
	D54911	D44911	D5D911	D4D911	Polypropylene	PTFE	PTFE	D05911	241657	246946
	D54966	D44966	D5D966	D4D966	Polypropylene	Santoprene	Santoprene	D05966	241657	246946

* Requires CycleFlo or external valve control

** Air control includes air regulator and filter with gauge

Husky 716 Metal Pumps



Technical Specifications

Husky 716 Metal Pumps	Aluminium	Stainless Steel
Maximum fluid working pressure	7 bar (0.7 MPa-100 psi)	7 bar (0.7 MPa-100 psi)
Maximum free flow delivery*	61 l/min (16 gpm)	61 l/min (16 gpm)
Maximum pump speed	400 cpm	400 cpm
Displacement per cycle**	0.15 liter (0.04 gallon)	0.15 liter (0.04 gallon)
Maximum suction lift	4.5 m (15 ft) dry	4.5 m (15 ft) dry
Maximum size pumpable solids	2.5 mm (0.09 in)	2.5 mm (0.09 in)
Maximum diaphragm operating temperature***		
PTFE	104.4°C (220°F)	104.4°C (220°F)
Santoprene	82.2°C (180°F)	82.2°C (180°F)
Buna-N	82.2°C (180°F)	82.2°C (180°F)
TPE	65.5°C (150°F)	65.5°C (150°F)
Fluoroelastomer	121.1°C (250°F)	121.1°C (250°F)
Typical sound level at 4.9 bar air (0.49 MPa-70 psi) air @ 200 cpm	74 dBa	74 dBa
Maximum air consumption	0.672 m ³ /min (28 scfm)	0.672 m ³ /min (28 scfm)
Air pressure operating range	2.1 to 7 bar (0.21 to 0.7 MPa-30 to 100 psi)	2.1 to 7 bar (0.21 to 0.7 MPa-30 to 100 psi)
Air inlet size	1/4 npt(f)	1/4 npt(f)
Air exhaust port size	3/8 npt(f)	3/8 npt(f)
Fluid inlet & outlet size	3/4 npt(f) or bspt(f)	3/4 npt(f) or bspt(f)
Weight	3.9 kg (8.5 lb)	8.2 kg (18 lb)
Wetted parts (in addition to ball, seat and diaphragm materials-which may vary by pump)	Aluminium, Stainless Steel, PTFE, Buna-N, Santoprene, Zinc-Plated Steel	Acetal, Polypropylene, Stainless Steel, Polyester, Santoprene, Fluoroelastomer, Nickel-Plated Brass, Epoxy-Coated Steel
Instruction manual	308981	308981

*Flow rates are with muffler and do not vary based on diaphragm material

**Displacement per cycle may vary based on suction condition, discharge head, air pressure and fluid type

***Actual pump performance may be affected by prolonged usage at temperature

Performance Charts

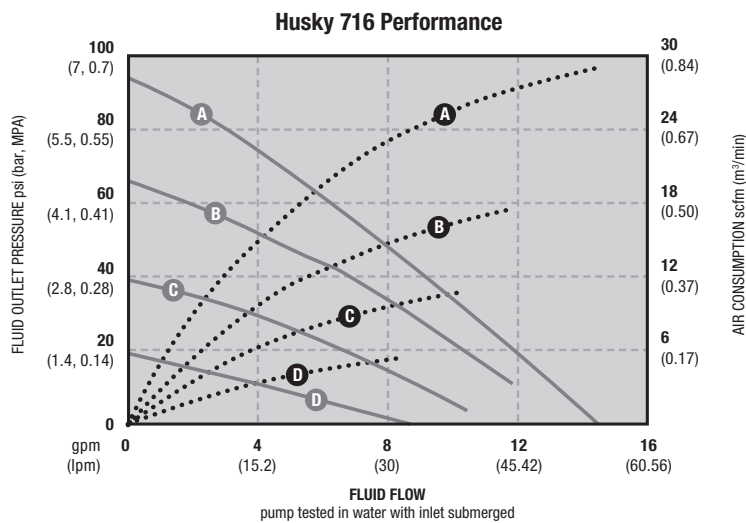

AIR PRESSURE	LEGEND
Ⓐ = at 7 bar (0.7 MPa - 100 psi)	Air Consumption (dotted line)
Ⓑ = at 4.8 bar (0.48 MPa - 70 psi)	Fluid Flow _____ (solid line)
Ⓒ = at 2.8 bar (0.28 MPa - 40 psi)	
Ⓓ = at 1.4 bar (0.14 MPa - 20 psi)	

Husky 716 Metal Pumps

Dimensions

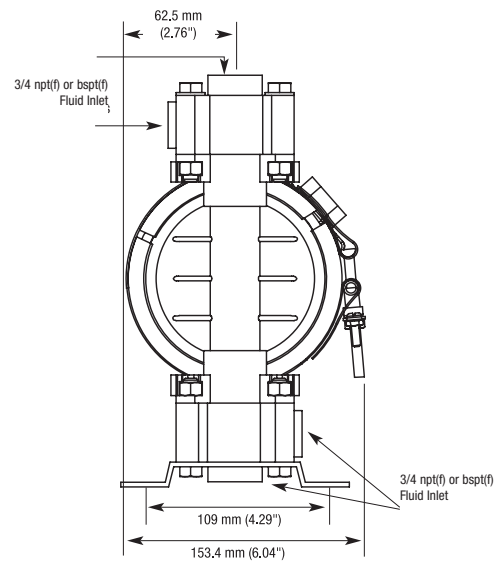
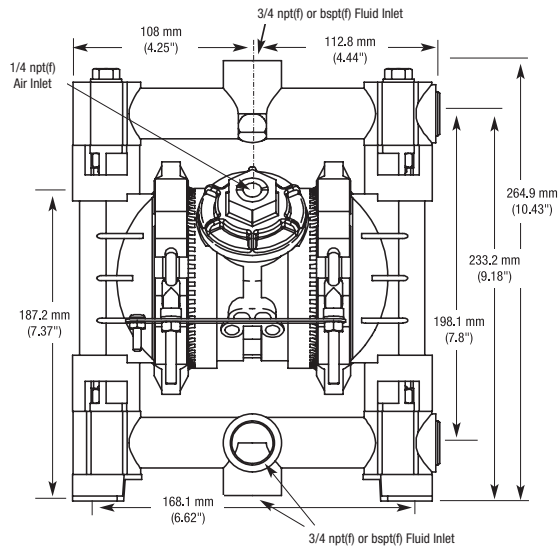

Typical System Drawings

Husky 716 Wall-Mount with Drum Feed

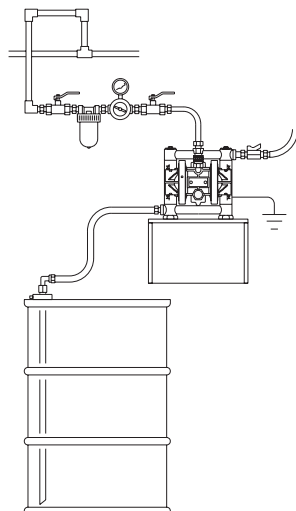

Husky 716 Drum-Mount with Siphon Feed

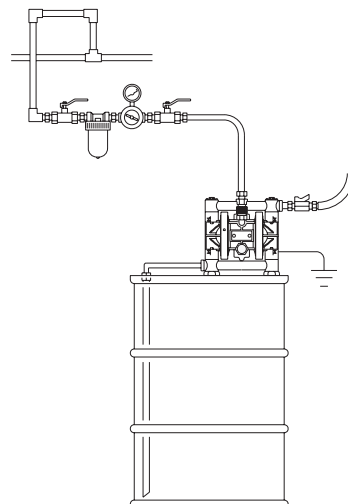

Husky 1050 Plastic Pumps Air-Operated Double Diaphragm

NEW! Husky 1050 Selector Tool

To order a Husky 1050, use the online selector tool at www.graco.com or contact your distributor.

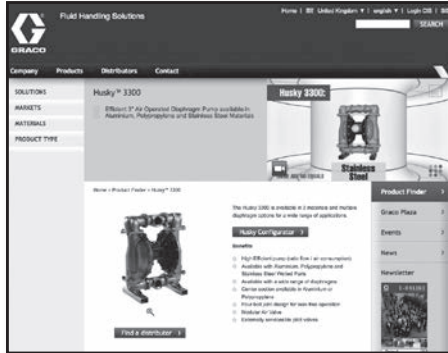

NOTE: Options for seats, check balls, diaphragms, and seals vary for the 1050A, 1050C, 1050F, 1050H, 1050P, and 1050S pump models.

Graco Part Number: 649001
Configuration Number: 1050P-P01AP1PPSPSPPT
Old "D" Graco Number: D72966

Replacement Kits
24B773-40 T,AIRVALVE,POLY,STD
24B635 - KIT,1050,POLYPROPYLENE SEAT
24B646 - KIT,1050,SANTOPRENE BALL
24B628 - KIT,1050,SANTOPRENE DIAPHRAGM

Example of Product Selector Tool on www.graco.com/process.

Pump Configurations

Pump (1 inch ports, 50 gpm)	Center Section and Air Valve Material	Air Valve/Monitoring	Fluid Covers and Manifolds
1050C ★ Conductive Polypropylene	Conductive Polypropylene	C01A Standard	C1 Conductive polypropylene, center flange
		C01B Pulse Count ✘	C2 Conductive polypropylene, end flange
		C01C DataTrak ✘	
		C01D Remote	
1050P Polypropylene	Polypropylene	P01A Standard	P1 Polypropylene, center flange
		P01B Pulse Count ✘	P2 Polypropylene, end flange
1050F PVDF		P01C DataTrak ✘	F1 PVDF, center flange
		P01D Remote	F2 PVDF, end flange

★, ‡, or ✘: See ATEX Certifications below.

Check Valve Seats		Check Valve Balls		Diaphragm		Manifold O-Rings	
AC	Acetal	AC	Acetal	BN	Buna-N	—	None
FK	FKM Fluoroelastomer	BN	Buna-N	CO	Polychloroprene Overmolded	PT	PTFE
PP	Polypropylene	FK	FKM Fluoroelastomer	FK	FKM Fluoroelastomer		
PV	PVDF	PT	PTFE	PO	PTFE/EPDM Overmolded		
SP	Santoprene®	SP	Santoprene	PT	PTFE/EPDM Two-Piece		
SS	316 Stainless Steel	SS	316 Stainless Steel	SP	Santoprene		
BN	Buna-N	TP	TPE	TP	TPE		
AL	Aluminium	GE	Geolast	GE	Geolast		
GE	Geolast	CR	Polychloroprene				
TP	TPE	CW	Polychloroprene w/SST Core				

ATEX Certifications

★ All **1050C** (Conductive Polypropylene) pumps are certified: II 2 G c IIC T4

✘ DataTrak and Pulse Count are certified: II 2 G

EEx ia IIA T3
Nemko
06ATEX1124

Popular Models

Material	Part Number	Materials for Seats	Materials for Balls	Materials for Diaphragms	Air Valve Replacement Kit	Seat Kit	Ball Kit	Diaphragm Kit	Flange
	Standard Air Valve								
Polypropylene	649001	Polypropylene	Santoprene	Santoprene	24B773	24B635	24B646	24B628	Center
	649006	Polypropylene	PTFE	PTFE/EPDM 2 Piece	24B773	24B635	24B645	24B627	Center
	649034	Polypropylene	PTFE	PTFE/EPDM 2 Piece	24B773	24B635	24B645	24B627	End
Conductive Polypropylene	649218	Acetal	PTFE	PTFE/EPDM 2 Piece	24B775	24B630	24B645	24B627	End
	649211	316 SST	PTFE	PTFE/EPDM 2 Piece	24B775	24B637	24B645	24B627	End
PVDF	649392	316 SST	PTFE	PTFE/EPDM 2 Piece	24B773	24B637	24B645	24B627	End
	649398	PVDF	PTFE	PTFE/EPDM 2 Piece	24B773	24C721	24B645	24B627	End



Technical Specifications

Husky 1050 Plastic Pumps	Conductive Polypropylene	Polypropylene	PVDF
Maximum fluid working pressure	8.6 bar (0.86 MPa - 125 psi)	8.6 bar (0.86 MPa - 125 psi)	8.6 bar (0.86 MPa - 125 psi)
Maximum free flow delivery	189 l/min (50 gpm)	189 l/min (50 gpm)	189 l/min (50 gpm)
Maximum pump speed	280 cpm	280 cpm	280 cpm
Displacement per cycle	0.64 liters (0.17 gal)	0.64 liters (0.17 gal)	0.64 liters (0.17 gal)
Maximum suction lift	4.9 m (16 ft) dry, 8.8 m (29 ft) wet	4.9 m (16 ft) dry, 8.8 m (29 ft) wet	4.9 m (16 ft) dry, 8.8 m (29 ft) wet
Maximum size pumpable solids	3.2 mm (1/8 in)	3.2 mm (1/8 in)	3.2 mm (1/8 in)
Sound Power* at 4.8 bar (0.48 MPa - 70 psi) and 50 cpm at 7.0 bar (0.7 MPa - 100 psi) and full flow	78 dBA 90 dBA	78 dBA 90 dBA	78 dBA 90 dBA
Sound Pressure** at 4.8 bar (0.48 MPa - 70 psi) and 50 cpm at 7.0 bar (0.7 MPa - 100 psi) and full flow	84 dBA 96 dBA	84 dBA 96 dBA	84 dBA 96 dBA
Maximum air consumption	67 scfm	67 scfm	67 scfm
Air consumption at 4.8 bar (0.48 MPa - 70 psi), 76 l/min (20 gpm)	25 scfm	25 scfm	25 scfm
Air pressure operating range	1.4-8.6 bar (0.14-0.86 MPa / 20-125 psi)	1.4-8.6 bar (0.14-0.86 MPa / 20-125 psi)	1.4-8.6 bar (0.14-0.86 MPa / 20-125 psi)
Air inlet size	1/2 npt(f)	1/2 npt(f)	1/2 npt(f)
Fluid inlet size	1 in raised face ANSI/DIN flange	1 in raised face ANSI/DIN flange	1 in raised face ANSI/DIN flange
Fluid outlet size	1 in raised face ANSI/DIN flange	1 in raised face ANSI/DIN flange	1 in raised face ANSI/DIN flange
Weight	8.2 kg (18 lb)	8.2 kg (18 lb)	11.8 kg (26 lb)
Wetted parts	polypropylene and material(s) chosen for seat, ball, and diaphragm options	polypropylene and material(s) chosen for seat, ball, and diaphragm options	PVDF and material(s) chosen for seat, ball, and diaphragm options
Non-wetted Parts Center Bolts	polypropylene stainless steel	polypropylene stainless steel	polypropylene stainless steel
Instruction manual	312877	312877	312877
Repair/parts manual	313435	313435	313435

* Sound power measured per ISO-9614-2.

** Sound pressure was tested 1 m (3.28 ft) from equipment.

Husky 1050 Plastic Pumps

Performance Charts

Husky 1050 Performance

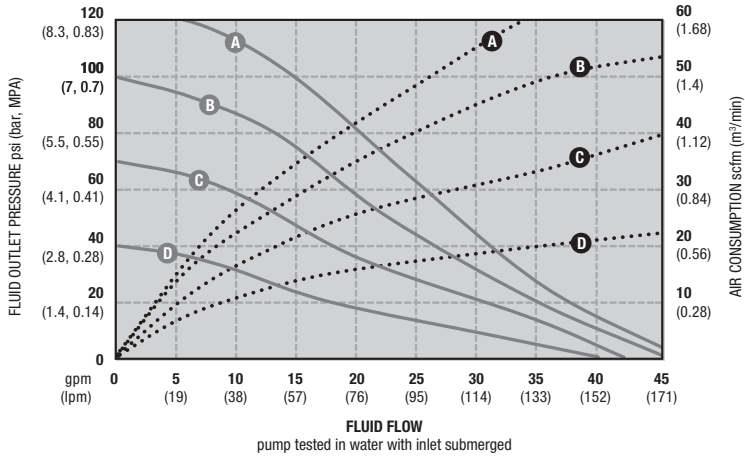

AIR PRESSURE	LEGEND
(A) = at 7 bar (0.7 MPa - 100 psi)	Air Consumption
(B) = at 4.8 bar (0.48 MPa - 70 psi)	Fluid Flow _____
(C) = at 2.8 bar (0.28 MPa - 40 psi)	
(D) = at 1.4 bar (0.14 MPa - 20 psi)	

Mounting Pattern

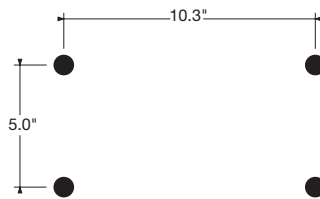

Dimensions

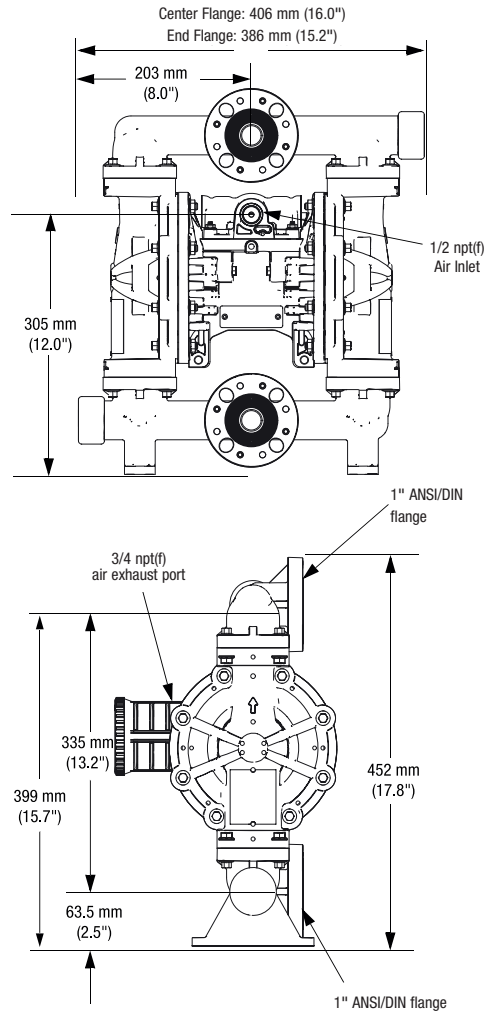

Typical System Drawings

Husky 1050 Floor-Mount

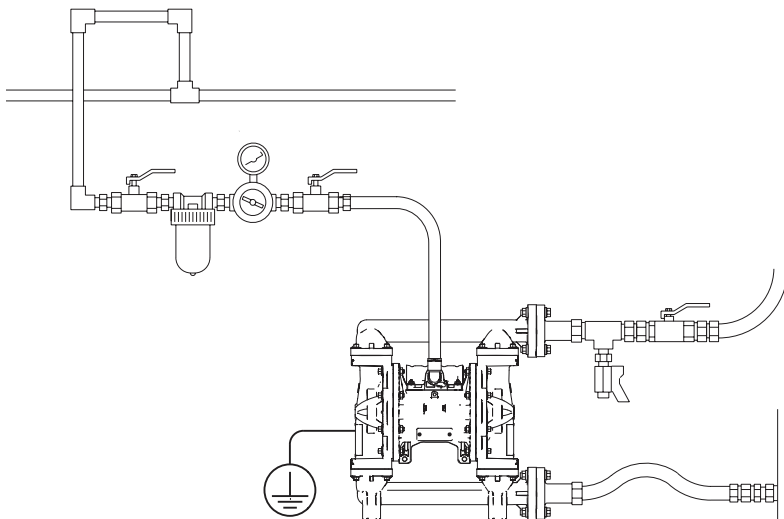

Husky 1050 Metal Pumps Air-Operated Double Diaphragm

Husky 1050 Selector Tool

To order a Husky 1050, use the online selector tool at www.graco.com or contact your distributor.

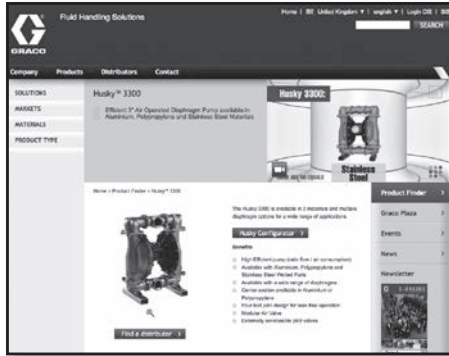

NOTE: Options for seats, check balls, diaphragms, and seals vary for the 1050A, 1050C, 1050F, 1050H, 1050P, and 1050S pump models.

Husky™
Air-Operated Double Diaphragm Pumps

Certification Required: ATEX
 Pump Inlet/Outlet Size: One Inch (25mm)
 Fluid Covers and Manifolds: [A] Aluminum
 Center Section and Air Valve: [A01A] Aluminum Standard Air Valve w/Buna Seats
 Porting: [A1] Aluminum Standard Porting Inch (NPT)
 Seats: [PP] Polypropylene
 Balls: [TP] TPE
 Diaphragms: [TP] TPE
 Manifold O-Rings: [PT] PTFE Standard

Order number reverse look-up
 Enter a 6 digit Graco number, product configuration or old "D" number

Graco Part Number: 647000
 Configuration Number: 1050A-A01AA1PPTPTPT
 Old "D" Graco Number: D73955

Replacement Kits
 249766 - KIT REPLACEMENT STAND VALVE
 249835 - KIT 1050 POLYPROPYLENE SEAT
 249842 - KIT 1050 HYTREL BALL
 249824 - KIT 1050 HYTREL DIAPHRAGM

©2011 GRACO INC. PROVEN QUALITY. LEADING TECHNOLOGY.

Example of Product Selector Tool on www.graco.com/process.

Pump Configurations

Pump (1 inch ports, 50 gpm)	Center Section and Air Valve Material	Air Valve/Monitoring	Fluid Covers and Manifolds
1050A ★ Aluminum	Aluminum	A01 Standard	A1 Aluminum, standard ports, inch
		A01B Pulse Count ✘	A2 Aluminum, standard ports, metric
		A01C DataTrak ✘	S1 Stainless steel, standard ports, inch
		A01D Remote	S2 Stainless steel, standard ports, metric
1050S ‡ Stainless Steel	Conductive Polypropylene	C01A Standard	H1 Hastelloy, standard ports, inch
			H2 Hastelloy, standard ports, metric
1050H Hastelloy	Polypropylene	P01A Standard	
		P01B Pulse Count ✘	
		P01C DataTrak ✘	
		P01D Remote	

★, ‡, or ✘: See **ATEX Certifications** below.

Check Valve Seats		Check Valve Balls		Diaphragm		Manifold O-Rings	
AC	Acetal	AC	Acetal	BN	Buna-N	—	None
AL	Aluminium	BN	Buna-N	CO	Polychloroprene Overmolded	PT	PTFE
BN	Buna-N	CR	Polychloroprene Standard	FK	FKM Fluoroelastomer		
FK	FKM Fluoroelastomer	CW	Polychloroprene Weighted	GE	Geolast		
GE	Geolast®	FK	FKM Fluoroelastomer	PO	PTFE/EPDM Overmolded		
PP	Polypropylene	GE	Geolast	PT	PTFE/EPDM Two-Piece		
SP	Santoprene®	PT	PTFE	SP	Santoprene		
SS	316 Stainless Steel	SP	Santoprene	TP	TPE		
TP	TPE	SS	316 Stainless Steel				
		TP	TPE				

ATEX Certifications

★ All **1050A** (Aluminium) pumps are certified:

‡ **1050S** (Stainless Steel) pumps with Aluminium or conductive polypropylene centers are certified:

✘ DataTrak and Pulse Count are certified:

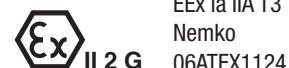

Husky 1050 Metal Pumps

Popular Models

Material	Part Number		Materials for Seats	Materials for Balls	Materials for Diaphragms	Air Valve Replacement Kit	Seat Kit	Ball Kit	Diaphragm Kit
	Standard Air Valve	Remote Air Valve							
Aluminium	647666	647502	Thermoplastic Polyester Elastomer	Acetal	Thermoplastic Polyester Elastomer	24B766	24B634	24B639	24B624
	647016 (UL Certified)		Thermoplastic Polyester Elastomer	Acetal	Thermoplastic Polyester Elastomer	24B766	24B634	24B639	24B624
	647075	647561	Acetal	PTFE	PTFE/EPDM 2 Piece	24B766	24B630	24B645	24B627
	647040	647526	Geolast	Geolast	Geolast	24B766	24B633	24B641	24B623
	647035	647521	Santoprene	Santoprene	Santoprene	24B766	24B636	24B646	24B628
	647028	647514	316 SST	PTFE	PTFE/EPDM 2 Piece	24B766	24B637	24B645	24B627
	647004	647490	Polypropylene	PTFE	PTFE/EPDM 2 Piece	24B766	24B635	24B645	24B627
Stainless Steel	647018	647504	316 SST	316 SST	PTFE/EPDM 2 Piece	24B766	24B637	24B647	24B627
	651009	651125	316 SST	PTFE	PTFE/EPDM 2 Piece	24B766	24B637	24B645	24B627
Hastelloy	651440		FKM	PTFE	PTFE/EPDM 2 Piece	24B775	24B638	24B645	24B627

Typical System Drawings

Husky 1050 Bung-Mount

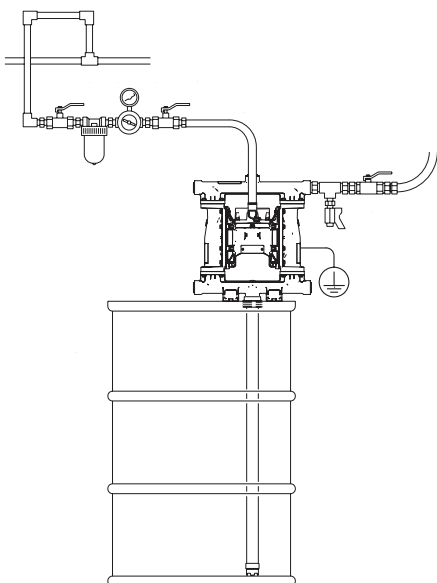

Husky 1050 Floor-Mount

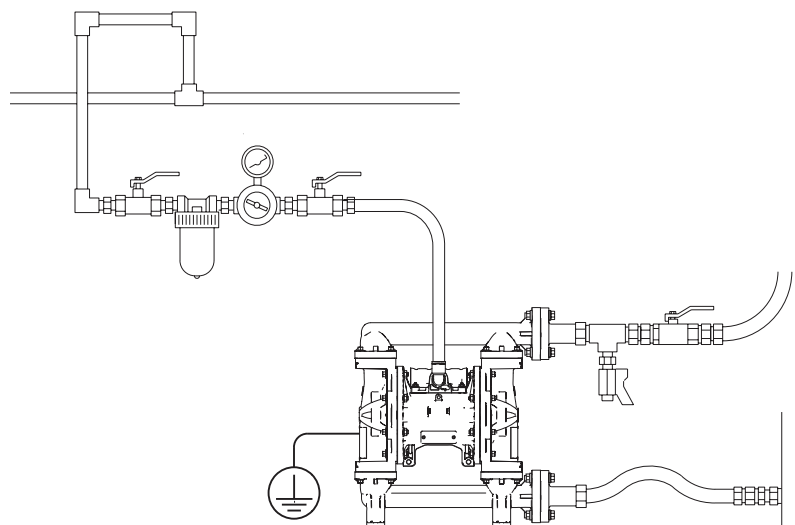

Husky 1050 Metal Pumps



Technical Specifications

Husky 1050 Metal Pumps	Aluminium	Stainless Steel	Hastelloy
Maximum fluid working pressure	8.6 bar (0.86 MPa - 125 psi)	8.6 bar (0.86 MPa - 125 psi)	8.6 bar (0.86 MPa - 125 psi)
Maximum free flow delivery	189 l/min (50 gpm)	189 l/min (50 gpm)	189 l/min (50 gpm)
Maximum pump speed	280 cpm	280 cpm	280 cpm
Displacement per cycle	0.64 liters (0.17 gal)	0.64 liters (0.17 gal)	0.64 liters (0.17 gal)
Maximum suction lift	4.9 m (16 ft) dry, 8.8 m (29 ft) wet	4.9 m (16 ft) dry, 8.8 m (29 ft) wet	4.9 m (16 ft) dry, 8.8 m (29 ft) wet
Maximum size pumpable solids	3.2 mm (1/8 in)	3.2 mm (1/8 in)	3.2 mm (1/8 in)
Sound Power* at 4.8 bar (0.48 MPa - 70 psi) and 50 cpm at 7.0 bar (0.7 MPa - 100 psi) and full flow	78 dBa 90 dBa	78 dBa 90 dBa	78 dBa 90 dBa
Sound Pressure** at 4.8 bar (0.48 MPa - 70 psi) and 50 cpm at 7.0 bar (0.7 MPa - 100 psi) and full flow	84 dBa 96 dBa	84 dBa 96 dBa	84 dBa 96 dBa
Maximum air consumption	67 scfm	67 scfm	67 scfm
Air consumption at 4.8 bar (0.48 MPa - 70 psi) / 76 l/min (20 gpm)	25 scfm	25 scfm	25 scfm
Air pressure operating range	1.4-8.6 bar (0.14-0.86 MPa / 20-125 psi)	1.4-8.6 bar (0.14-0.86 MPa / 20-125 psi)	1.4-8.6 bar (0.14-0.86 MPa / 20-125 psi)
Air inlet size	1/2 npt(f)	1/2 npt(f)	1/2 npt(f)
Fluid inlet size	1 in npt(f) or 1 in bspt	1 in npt(f) or 1 in bspt	1 in npt(f) or 1 in bspt
Fluid outlet size	1 in npt(f) or 1 in bspt	1 in npt(f) or 1 in bspt	1 in npt(f) or 1 in bspt
Weight	10.5 kg (23 lb)	with conductive polypropylene center 16.5 kg (36.3 lb) with polypropylene center 16.9 kg (37.3 lb) with Aluminium center 18.8 kg (41.4 lb)	18.6 kg (41 lb)
Wetted parts	Aluminium and material(s) chosen for seat, ball, and diaphragm options	stainless steel and material(s) chosen for seat, ball, and diaphragm options	hastelloy, stainless steel and material(s) chosen for seat, ball, and diaphragm options
Non-wetted Parts Center Bolts	Aluminium coated carbon steel	polypropylene stainless steel	Aluminium stainless steel
Instruction manual	312877	312877	312877
Repair/parts manual	313435	313435	313435

* Sound power measured per ISO-9614-2. ** Sound pressure was tested 3.28 ft (1 m) from equipment.

Performance Charts

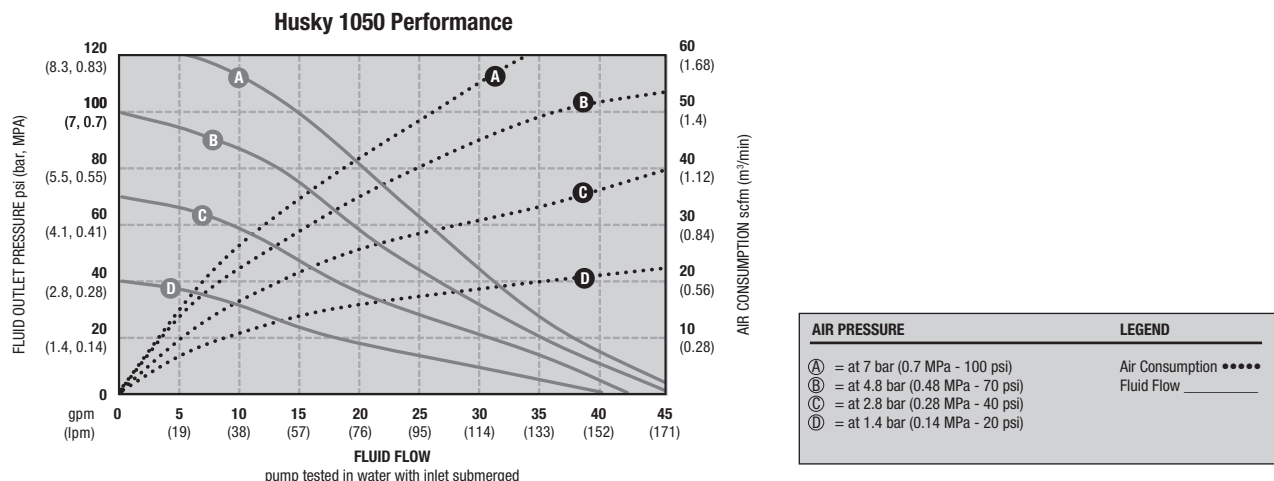

Husky 1050 Metal Pumps

Dimensions

Aluminium

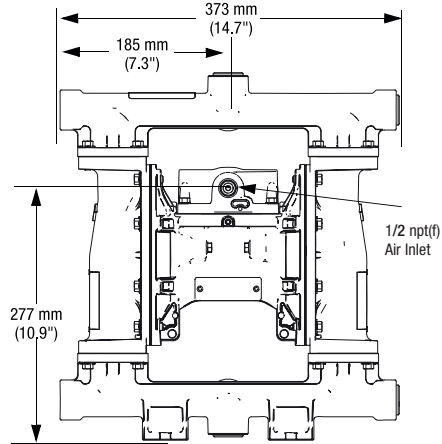
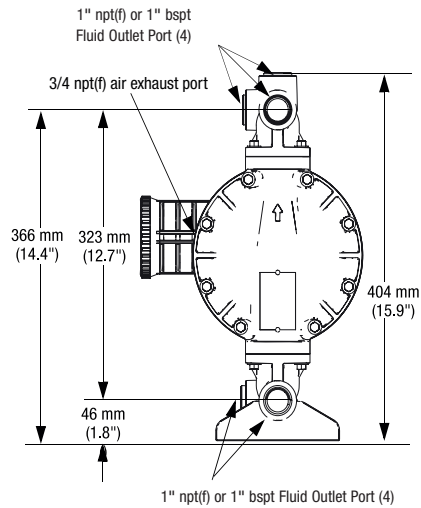

Mounting Pattern

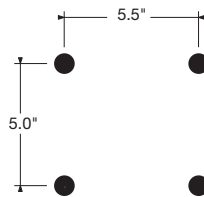

Stainless Steel

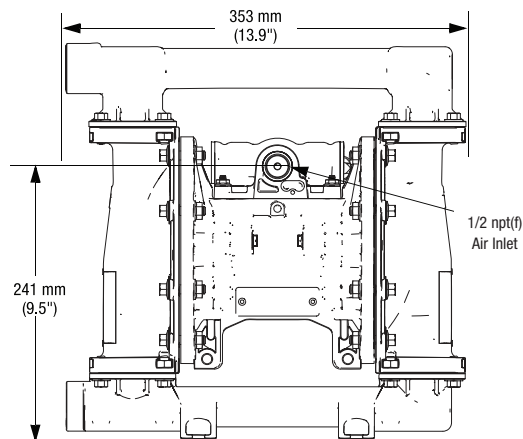
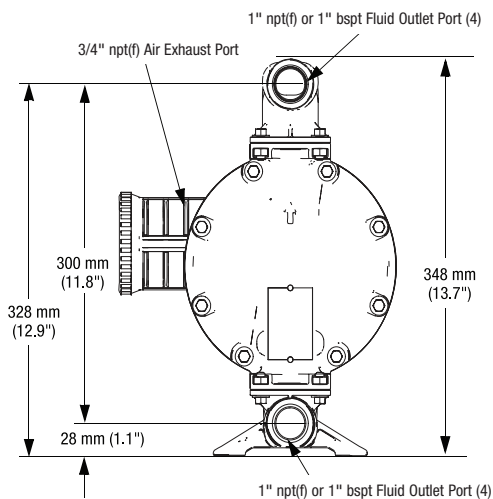

Mounting Pattern

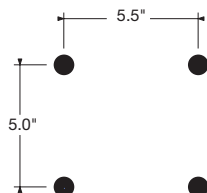

Husky 1590 Plastic Pumps

Air-Operated Double Diaphragm

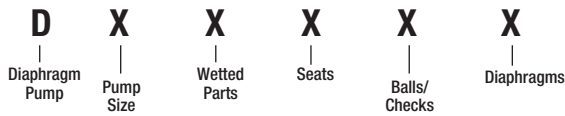

PUMP SIZE (AIR MOTOR TYPE AND MATERIAL)	WETTED PARTS	SEATS	BALLS	DIAPHRAGM
B = 38.1 mm (1-1/2") Standard: Aluminium center section	2 = Poly (npt)	3 = Stainless Steel	1 = PTFE	1 = PTFE
C = 38.1 mm (1-1/2") Remote: Aluminium center section	5 = PVDF (npt)	4 = Hardened SST	2 = Acetal	5 = TPE
T = 38.1 mm (1-1/2") Standard: stainless steel center section		5 = TPE	4 = Hardened SST	6 = Santoprene
U = 38.1 mm (1-1/2") Remote: stainless steel center section		6 = Santoprene	5 = TPE	7 = Buna N
		7 = Buna N	6 = Santoprene	8 = Fluoroelastomer
		8 = Fluoroelastomer	7 = Buna N	G = Geolast
		9 = Polypropylene	8 = Fluoroelastomer	
		A = PVDF	G = Geolast	
		G = Geolast		

Popular Models

Material	Part Number (ANSI-Flange)		Part Number (BSP Ported)		Materials for Seats	Materials for Balls	Materials for Diaphragms	Fluid Kit	Air Kit	Air Control**
	Standard Air Valve	Remote* Air Valve	Standard Air Valve	Remote* Air Valve						
Standard Pumps with Aluminium Center Section										
Polypropylene	DB2311				Stainless Steel	PTFE	PTFE	DOC311	236273	246947
	DB2377	DC2377			Stainless Steel	Buna	Buna	DOC377	236273	246947
	DB2777	DC2777			Buna	Buna	Buna	DOC777	236273	246947
	DB2888	DC2888			Fluoroelastomer	Fluoroelastomer	Fluoroelastomer	DOC888	236273	246947
	DB2911	DC2911			Polypropylene	PTFE	PTFE	DOC911	236273	246947
	DB2955				Polypropylene	TPE	TPE	DOC955	236273	246947
	DB2966				Polypropylene	Santoprene	Santoprene	DOC966	236273	246947
	DB2977				Polypropylene	Buna	Buna	DOC977	236273	246947
	DB2988				Polypropylene	Fluoroelastomer	Fluoroelastomer	DOC988	236273	246947
	DB29GG	DC29GG			Polypropylene	Geolast	Geolast	DOC9GG	236273	246947
PVDF	DB5311				Stainless Steel	PTFE	PTFE	DOC311	236273	246947
	DB5666				Santoprene	Santoprene	Santoprene	DOC666	236273	246947
	DB5811	DC5811			Fluoroelastomer	PTFE	PTFE	DOC811	236273	246947
	DB5888	DC5888			Fluoroelastomer	Fluoroelastomer	Fluoroelastomer	DOC888	236273	246947
	DB5A11	DC5A11			PVDF	PTFE	PTFE	DOCA11	236273	246947
	DB5A88				PVDF	Fluoroelastomer	Fluoroelastomer	DOCA88	236273	246947
Corrosion Resistant Pumps with Stainless Steel Center Section										
Polypropylene	DT2311	DU2311			Stainless Steel	PTFE	PTFE	DOC311	236273	246947
	DT2341	DU2331			Hardened SST	Stainless Steel	PTFE	DOC331	236273	246947
	DT2377	DU2377			Stainless Steel	Buna	Buna	DOC377	236273	246947
	DT2888	DU2888			Fluoroelastomer	Fluoroelastomer	Fluoroelastomer	DOC888	236273	246947
	DT2911	DU2911			Polypropylene	PTFE	PTFE	DOC911	236273	246947
	DT2977	DU2977			Polypropylene	Buna	Buna	DOC977	236273	246947
	DT2988	DU2988			Polypropylene	Fluoroelastomer	Fluoroelastomer	DOC988	236273	246947
PVDF	DT5311	DU5311			Stainless Steel	PTFE	PTFE	DOC311	236273	246947
	DT5811	DU5811			Fluoroelastomer	PTFE	PTFE	DOC811	236273	246947
	DT5888	DU5888			Fluoroelastomer	Fluoroelastomer	Fluoroelastomer	DOC888	236273	246947
	DT5A11	DU5A11			PVDF	PTFE	PTFE	DOCA11	236273	246947
	DT5A88	DU5A88			PVDF	Fluoroelastomer	Fluoroelastomer	DOCA88	236273	246947

*Requires CycleFlo or external valve control

** Air control includes air regulator and filter with gauge

Husky 1590 Plastic Pumps

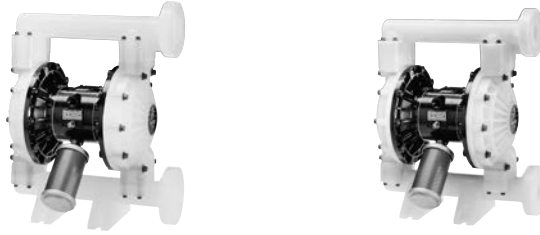

Technical Specifications

Husky 1590 Plastic Pumps	Polypropylene	PVDF
Maximum fluid working pressure	8.4 bar (0.84 MPa-120 psi)	8.4 bar (0.84 MPa-120 psi)
Maximum free flow delivery*	378.5 l/min (100 gpm)	378.5 l/min (100 gpm)
Maximum pump speed	200 cpm	200 cpm
Displacement per cycle**	1.96 liter (0.5 gallon)	1.96 liter (0.5 gallon)
Maximum suction lift (DB2366)	6.1 m (20 ft) dry	6.1 m (20 ft) dry
Maximum size pumpable solids	4.8 mm (0.19 in)	4.8 mm (0.19 in)
Maximum operating temperature***	65.5°C (150°F)	65.5°C (150°F)
Maximum diaphragm operating temperature***		
PTFE	104.4°C (220°F)	104.4°C (220°F)
Santoprene	82.2°C (180°F)	82.2°C (180°F)
Buna-N	82.2°C (180°F)	82.2°C (180°F)
TPE	65.5°C (150°F)	65.5°C (150°F)
Fluoroelastomer	121.1°C (250°F)	121.1°C (250°F)
Geolast	65.5°C (150°F)	65.5°C (150°F)
Typical sound level at 4.9 bar (0.49 MPa-70 psi) air @ 125 cpm	77 dBa	77 dBa
Maximum air consumption	3.5 m ³ /min. (125 scfm)	3.5 m ³ /min. (125 scfm)
Air pressure operating range	1.4 to 8.4 bar (0.14 to 0.84 MPa-20 to 120 psi)	1.4 to 8.4 bar (0.14 to 0.84 MPa-20 to 120 psi)
Air inlet size	1/2 npt(f)	1/2 npt(f)
Fluid inlet & outlet size	38.1 mm (1-1/2") ANSI-flange	38.1 mm (1-1/2") ANSI-flange
Weight	16 kg (35 lb)	22 kg (49 lb)
Weight with stainless steel center section	21.9 kg (48.3 lb)	28.2 kg (62.3 lb)
Instruction manual	308549	308549

* Flow rates are with muffler and do not vary based on diaphragm material

** Displacement per cycle may vary based on suction condition, discharge head, air pressure and fluid type

*** Actual pump performance may be affected by prolonged usage at temperature

Husky 1590 Plastic Pumps

Performance Charts

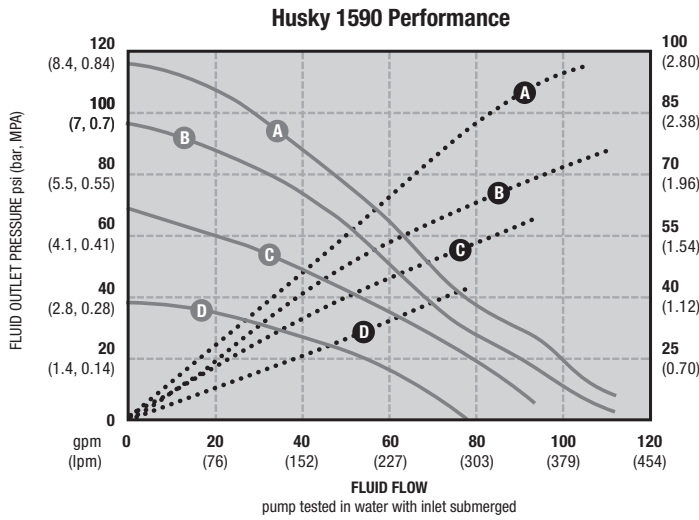

AIR PRESSURE	LEGEND
Ⓐ = at 7 bar (0.7 MPa - 100 psi)	Air Consumption ●●●●
Ⓑ = at 4.8 bar (0.48 MPa - 70 psi)	Fluid Flow ———
Ⓒ = at 2.8 bar (0.28 MPa - 40 psi)	
Ⓓ = at 1.4 bar (0.14 MPa - 20 psi)	

Dimensions

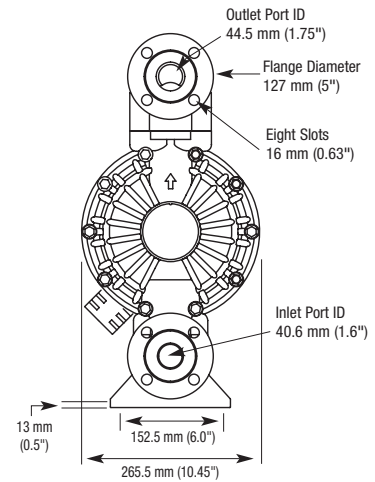
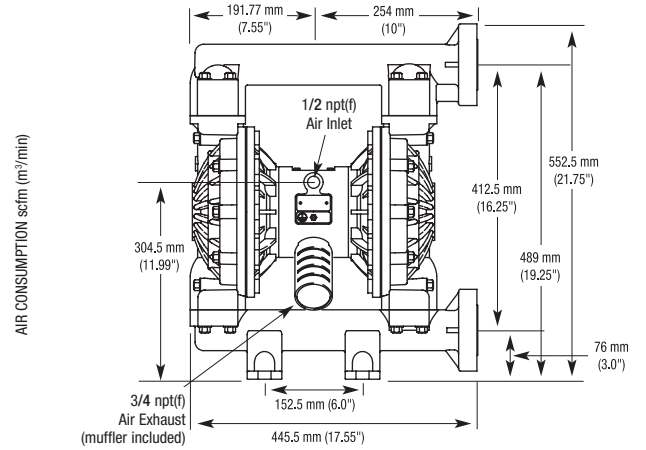

Typical System Drawings

Husky 1590 Above Ground Gravity Feed

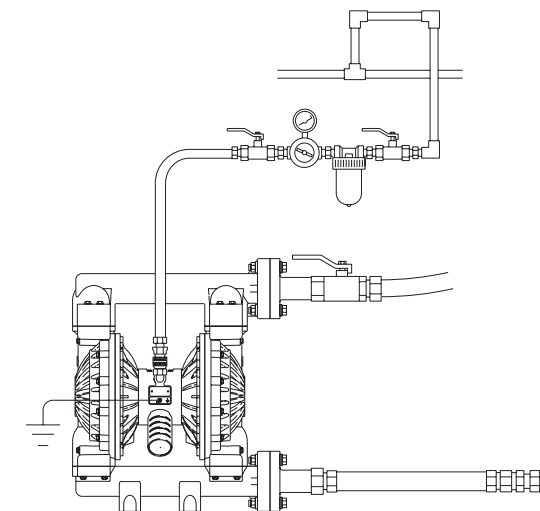

Husky 1590 Metal Pumps

Air-Operated Double Diaphragm

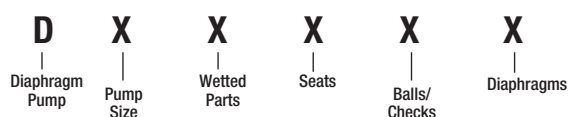

PUMP SIZE (AIR MOTOR TYPE AND MATERIAL)	WETTED PARTS	SEATS	BALLS	DIAPHRAGM
B = 38.1 mm (1-1/2") Standard: Aluminium center section	3 = Aluminium (npt)	3 = Stainless Steel	1 = PTFE	1 = PTFE
C = 38.1 mm (1-1/2") Remote: Aluminium center section	4 = Stainless Steel (npt)	4 = Hardened SST	2 = Acetal	5 = TPE
T = 38.1 mm (1-1/2") Standard: stainless steel center section	C = Aluminium (bsp)	5 = TPE	4 = Hardened SST	6 = Santoprene
U = 38.1 mm (1-1/2") Remote: stainless steel center section	D = Stainless Steel (bsp)	6 = Santoprene	5 = TPE	7 = Buna N
		7 = Buna N	6 = Santoprene	8 = Fluoroelastomer
		8 = Fluoroelastomer	7 = Buna N	G = Geolast
		9 = Polypropylene	8 = Fluoroelastomer	
		A = PVDF	G = Geolast	
		G = Geolast		

Popular Models

Material	Part Number (NPT Ported)		Part Number (BSP Ported)		Materials for Seats	Materials for Balls	Materials for Diaphragms	Fluid Kit	Air Kit	Air Control**
	Standard Air Valve	Remote* Air Valve	Standard Air Valve	Remote* Air Valve						
Standard Pumps with Aluminium Center Section										
Aluminium	DB3311	DC3311	DBC311	DCC311	Stainless Steel	PTFE	PTFE	DOB311	236273	246947
	DB3341		DBC341		Hardened SST	Stainless Steel	PTFE	DOB331	236273	246947
	DB3366	DC3366	DBC366	DCC366	Stainless Steel	Santoprene	Santoprene	DOB366	236273	246947
	DB3377	DC3377	DBC377	DCC377	Stainless Steel	Buna	Buna	DOB377	236273	246947
	DB3525	DC3525	DBC525	DCC525	TPE	Acetal	TPE	DOB525	236273	246947
	DB3555		DBC555		TPE	TPE	TPE	DOB555	236273	246947
	DB3666	DC3666	DBC666	DCC666	Santoprene	Santoprene	Santoprene	DOB666	236273	246947
	DB3777	DC3777	DBC777	DCC777	Buna	Buna	Buna	DOB777	236273	246947
	DB3888	DC3888	DBC888	DCC888	Fluoroelastomer	Fluoroelastomer	Fluoroelastomer	DOB888	236273	246947
	DB3GGG	DC3GGG	DBC3GGG	DCC3GGG	Geolast	Geolast	Geolast	DOB3GGG	236273	246947
	DB3911		DBC911		Polypropylene	PTFE	PTFE	DOB911	236273	246947
	DB3977		DBC977		Polypropylene	Buna	Buna	DOB977	236273	246947
Stainless Steel	DB4311	DC4311	DBD311	DCD311	Stainless Steel	PTFE	PTFE	DOB311	236273	246947
	DB4341		DBD341		Stainless Steel	Hardened SST	PTFE	DOB341	236273	246947
	DB4377	DC4377	DBD377	DCD377	Stainless Steel	Buna	Buna	DOB377	236273	246947
	DB4525		DBD525		TPE	Acetal	TPE	DOB525	236273	246947
	DB4666	DC4666	DBD666	DCD666	Santoprene	Santoprene	Santoprene	DOB666	236273	246947
	DB4777	DC4777	DBD777	DCD777	Buna	Buna	Buna	DOB777	236273	246947
	DB4888	DC4888	DBD888	DCD888	Fluoroelastomer	Fluoroelastomer	Fluoroelastomer	DOB888	236273	246947
	DB4GGG	DC4GGG	DBDGGG	DCDGGG	Geolast	Geolast	Geolast	DOBGGG	236273	246947
	DB4911		DBD911		Polypropylene	PTFE	PTFE	DOB911	236273	246947
Corrosion Resistant Pumps with Stainless Steel Center Section										
Stainless Steel	DT4311	DU4311	DTD311	DUD311	Stainless Steel	PTFE	PTFE	DOB311	255061	246947
	DT4377	DU4377	DTD377	DUD377	Stainless Steel	Buna	Buna	DOB377	255061	246947
	DT4388	DU4388	DTD388	DUD388	Stainless Steel	Fluoroelastomer	Fluoroelastomer	DOB388	255061	246947
	DT4666	DU4666	DTD666	DUD666	Santoprene	Santoprene	Santoprene	DOB666	255061	246947
	DT4888	DU4888	DTD888	DUD888	Fluoroelastomer	Fluoroelastomer	Fluoroelastomer	DOB888	255061	246947
	DT4911	DU4911	DTD911	DUD911	Polypropylene	PTFE	PTFE	DOB911	255061	246947

*Requires CycleFlo or external valve control

** Air control includes air regulator and filter with gauge

Husky 1590 Metal Pumps



Technical Specifications

Husky 1590 Metal Pumps	Aluminium	Stainless Steel
Maximum fluid working pressure	8.4 bar (0.84 MPa - 120 psi)	8.4 bar (0.84 MPa - 120 psi)
Maximum free flow delivery*	378.5 l/min (100 gpm)	378.5 l/min (100 gpm)
Maximum pump speed	200 cpm	200 cpm
Displacement per cycle**	1.96 liter (0.5 gallon)	1.96 liter (0.5 gallon)
Maximum suction lift (DB2366)	6.1 m (20 ft) dry	6.1 m (20 ft) dry
Maximum size pumpable solids	4.8 mm (0.19 in)	4.8 mm (0.19 in)
Maximum operating temperature***	65.5°C (150°F)	65.5°C (150°F)
Maximum diaphragm operating temperature***		
PTFE	104.4°C (220°F)	104.4°C (220°F)
Santoprene	82.2°C (180°F)	82.2°C (180°F)
Buna-N	82.2°C (180°F)	82.2°C (180°F)
TPE	65.5°C (150°F)	65.5°C (150°F)
Fluoroelastomer	121.1°C (250°F)	121.1°C (250°F)
Geolast	65.5°C (150°F)	65.5°C (150°F)
Typical sound level at 70 psi (4.9 bar, 0.49 MPa) air @ 125 cpm	77 dBa	77 dBa
Maximum air consumption	3.5 m ³ /min. (125 scfm)	3.5 m ³ /min. (125 scfm)
Air pressure operating range	1.4 to 8.4 bar (0.14 to 0.84 MPa / 20 to 120 psi)	1.4 to 8.4 bar (0.14 to 0.84 MPa / 20 to 120 psi)
Air inlet size	1/2 npt(f)	1/2 npt(f)
Fluid inlet & outlet size	1-1/2 npt(f) or bspt(f)	1-1/2 npt(f) or bspt(f)
Weight	15.2 kg (33.5 lb)	40 kg (86 lb)
Weight with stainless steel center section	not available	44.8 kg (98.8 lb)
Instruction manual	308441	308441

*Flow rates are with muffler and do not vary based on diaphragm material

**Displacement per cycle may vary based on suction condition, discharge head, air pressure and fluid type

*** Actual pump performance may be affected by prolonged usage at temperature

Husky 1590 Metal Pumps

Performance Charts

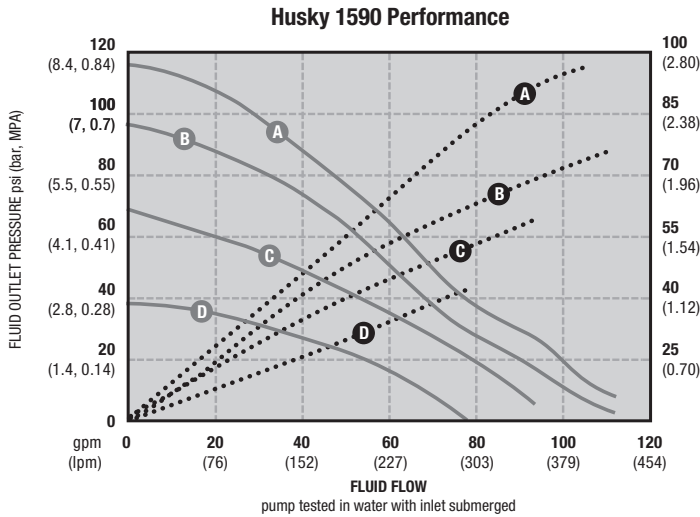

AIR PRESSURE	LEGEND
(A) = at 7 bar (0.7 MPa - 100 psi)	Air Consumption ●●●●●
(B) = at 4.8 bar (0.48 MPa - 70 psi)	Fluid Flow _____
(C) = at 2.8 bar (0.28 MPa - 40 psi)	
(D) = at 1.4 bar (0.14 MPa - 20 psi)	

Dimensions

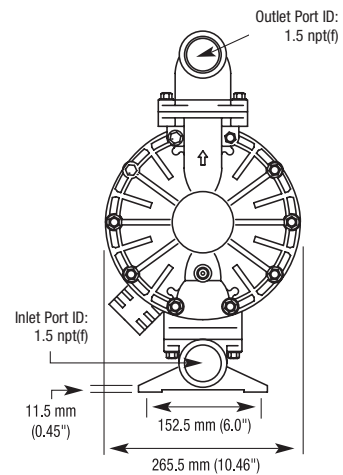
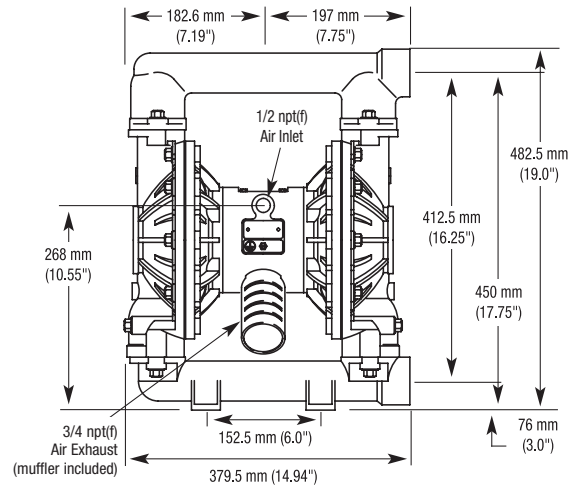

Typical System Drawings

Husky 1590 Above Ground Gravity Feed

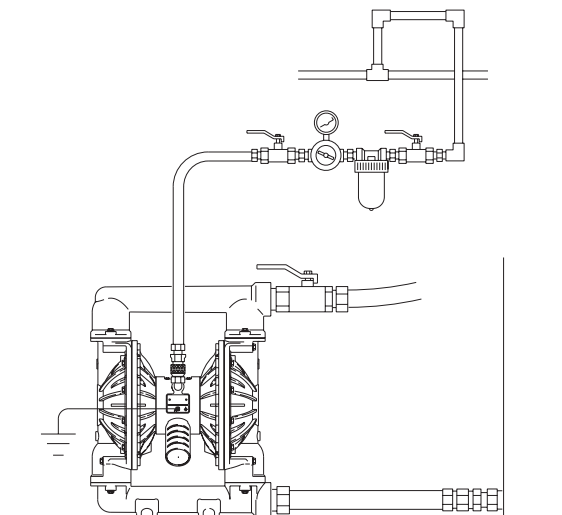

Husky 2150 Plastic Pumps

Air-Operated Double Diaphragm

D Diaphragm Pump
X Pump Size
X Wetted Parts
X Seats
X Balls/Checks
X Diaphragms

PUMP SIZE (AIR MOTOR TYPE AND MATERIAL)	WETTED PARTS	SEATS	BALLS	DIAPHRAGM
F = 50.8 mm (2") Standard: Aluminium center section	2 = Poly (npt)	3 = Stainless Steel	1 = PTFE	1 = PTFE
G = 50.8 mm (2") Remote: Aluminium center section	5 = PVDF (npt)	4 = Hardened SST	2 = Acetal	5 = TPE
V = 50.8 mm (2") Standard: stainless steel center section		5 = TPE	4 = Hardened SST	6 = Santoprene
		6 = Santoprene	5 = TPE	7 = Buna N
		7 = Buna N	6 = Santoprene	8 = Fluoroelastomer
		8 = Fluoroelastomer	7 = Buna N	G = Geolast
		9 = Polypropylene	8 = Fluoroelastomer	
		A = PVDF	G = Geolast	
		G = Geolast		

Popular Models

Material	Part Number (ANSI-Flange)		Part Number (BSP Ported)		Materials for Seats	Materials for Balls	Materials for Diaphragms	Fluid Kit	Air Kit	Air Control**
	Standard Air Valve	Remote* Air Valve	Standard Air Valve	Remote* Air Valve						
Standard Pumps with Aluminium Center Section										
Polypropylene	DF2311				Stainless Steel	PTFE	PTFE	D0G311	236273	246947
	DF2377	DG2377			Stainless Steel	Buna	Buna	D0G377	236273	246947
	DF2777	DG2777			Buna	Buna	Buna	D0G777	236273	246947
	DF2888	DG2888			Fluoroelastomer	Fluoroelastomer	Fluoroelastomer	D0G888	236273	246947
	DF2911	DG2911			Polypropylene	PTFE	PTFE	D0G911	236273	246947
	DF2955				Polypropylene	TPE	TPE	D0G955	236273	246947
	DF2966				Polypropylene	Santoprene	Santoprene	D0G966	236273	246947
	DF2977				Polypropylene	Buna	Buna	D0G977	236273	246947
	DF2988				Polypropylene	Fluoroelastomer	Fluoroelastomer	D0G988	236273	246947
	DF29GG	DG29GG			Polypropylene	Geolast	Geolast	D0G9GG	236273	246947
PVDF	DF5311				Stainless Steel	PTFE	PTFE	D0G311	236273	246947
	DF5666				Santoprene	Santoprene	Santoprene	D0G666	236273	246947
	DF5811	DG5811			Fluoroelastomer	PTFE	PTFE	D0G811	236273	246947
	DF5888	DG5888			Fluoroelastomer	Fluoroelastomer	Fluoroelastomer	D0G888	236273	246947
	DF5A11	DG5A11			PVDF	PTFE	PTFE	D0GA11	236273	246947
	DF5A88				PVDF	Fluoroelastomer	Fluoroelastomer	D0GA88	236273	246947
Corrosion Resistant Pumps with Stainless Steel Center Section										
Polypropylene	DV2311				Stainless Steel	PTFE	PTFE	D0G311	236273	246947
	DV2341				Stainless Steel	Hardened SST	PTFE	D0G341	236273	246947
	DV2377				Stainless Steel	Buna	Buna	D0G377	236273	246947
	DV2888				Fluoroelastomer	Fluoroelastomer	Fluoroelastomer	D0G888	236273	246947
	DV2911				Polypropylene	PTFE	PTFE	D0G911	236273	246947
	DV2977				Polypropylene	Buna	Buna	D0G977	236273	246947
	DV2988				Polypropylene	Fluoroelastomer	Fluoroelastomer	D0G988	236273	246947
	DV2A11				PVDF	PTFE	PTFE	D0GA11	236273	246947
	DV2A88				PVDF	Fluoroelastomer	Fluoroelastomer	D0GA88	236273	246947
PVDF	DV5311				Stainless Steel	PTFE	PTFE	D0G311	236273	246947
	DV5811				Fluoroelastomer	PTFE	PTFE	D0G811	236273	246947
	DV5888				Fluoroelastomer	Fluoroelastomer	Fluoroelastomer	D0G888	236273	246947
	DV5A11				PVDF	PTFE	PTFE	D0GA11	236273	246947
	DV5A88				PVDF	Fluoroelastomer	Fluoroelastomer	D0GA88	236273	246947

*Requires CycleFlo or external valve control

** Air control includes air regulator and filter with gauge

Husky 2150 Plastic Pumps

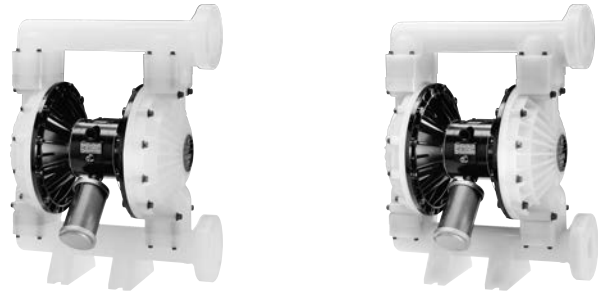

Technical Specifications

Husky 2150 Plastic Pumps	Polypropylene	PVDF
Maximum fluid working pressure	8.4 bar (0.84 MPa-120 psi)	8.4 bar (0.84 MPa-120 psi)
Maximum free flow delivery*	568 l/min (150 gpm)	568 l/min (150 gpm)
Maximum pump speed	145 cpm	145 cpm
Displacement per cycle**	3.90 liter (1.03 gallon)	3.90 liter (1.03 gallon)
Maximum suction lift	5.48 m (18 ft) wet or dry	5.48 m (18 ft) wet or dry
Maximum size pumpable solids	6.3 mm (0.25")	6.3 mm (0.25")
Maximum operating temperature***	65.5°C (150°F)	65.5°C (150°F)
Maximum diaphragm operating temperature***		
PTFE	104.4°C (220°F)	104.4°C (220°F)
Santoprene	82.2°C (180°F)	82.2°C (180°F)
Buna-N	82.2°C (180°F)	82.2°C (180°F)
TPE	65.5°C (150°F)	65.5°C (150°F)
Fluoroelastomer	121.1°C (250°F)	121.1°C (250°F)
Geolast	65.5°C (150°F)	65.5°C (150°F)
Typical sound level at 4.9 bar (0.49 MPa-70 psi) air @ 125 cpm	78 dBa	78 dBa
Maximum air consumption	4.9 m ³ /min (175 scfm)	4.9 m ³ /min (175 scfm)
Air consumption at 4.9 bar (0.49 MPa-70 psi) / 226 l/min (60 gpm)	1.7 m ³ /min (60 scfm)	1.7 m ³ /min (60 scfm)
Air pressure operating range	1.4 to 8.4 bar (0.14 to 0.84 MPa-20 to 120 psi)	1.4 to 8.4 bar (0.14 to 0.84 MPa-20 to 120 psi)
Air inlet size	1/2 npt(f)	1/2 npt(f)
Fluid inlet & outlet size	51 mm (2") ANSI-flange	51 mm (2") ANSI-flange
Weight	22 kg (49 lb)	30.8 kg (68 lb)
Weight with stainless steel center section	31 kg (68.5 lb)	39.6 kg (87.5 lb)
Instruction manual	308550	308550

* Flow rates are with muffler and do not vary based on diaphragm material

** Displacement per cycle may vary based on suction condition, discharge head, air pressure and fluid type

*** Actual pump performance may be affected by prolonged usage at temperature

Husky 2150 Plastic Pumps

Performance Charts

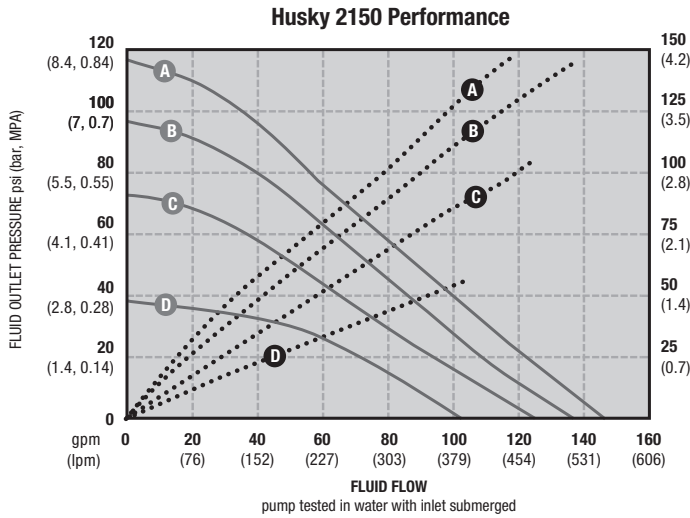

AIR PRESSURE	LEGEND
(A) = at 7 bar (0.7 MPa - 100 psi)	Air Consumption •••••
(B) = at 4.8 bar (0.48 MPa - 70 psi)	Fluid Flow ———
(C) = at 2.8 bar (0.28 MPa - 40 psi)	
(D) = at 1.4 bar (0.14 MPa - 20 psi)	

Dimensions

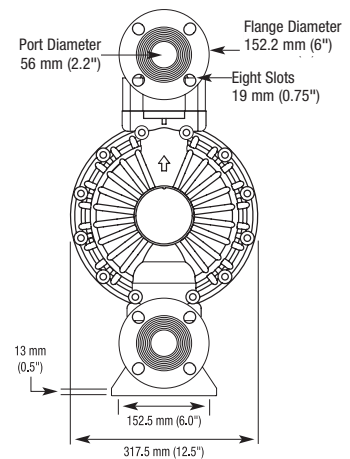
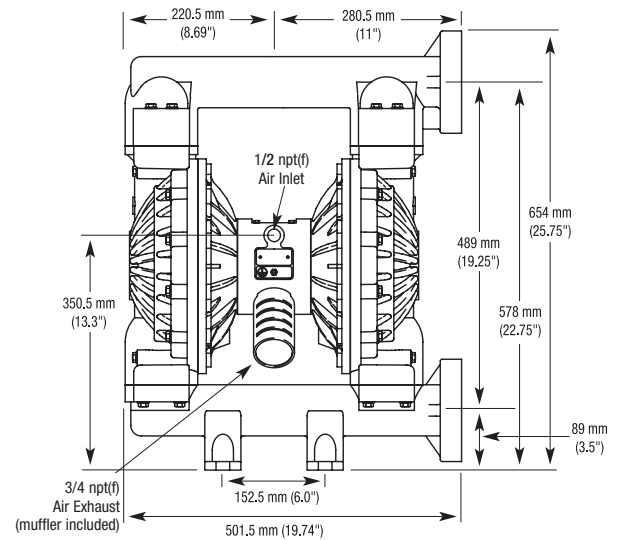

Typical System Drawings

Husky 2150 Above Ground Gravity Feed

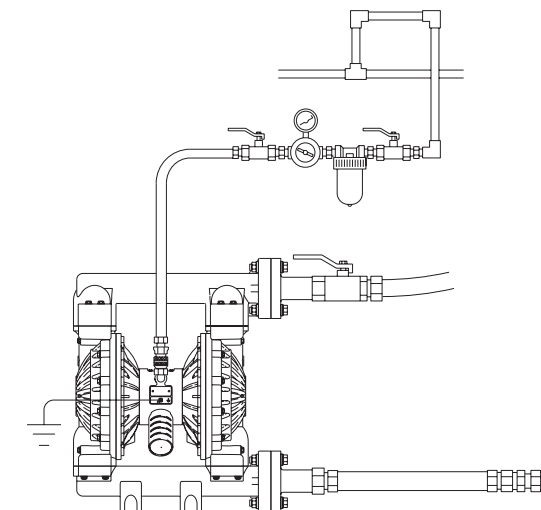

Husky 2150 Metal Pumps

Air-Operated Double Diaphragm

Ordering Information

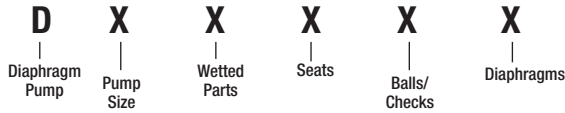

PUMP SIZE (AIR MOTOR TYPE AND MATERIAL)	WETTED PARTS	SEATS	BALLS	DIAPHRAGM
F = 50.8 mm (2") Standard: Aluminium center section	3 = Aluminium (npt)	3 = Stainless Steel	1 = PTFE	1 = PTFE
G = 50.8 mm (2") Remote: Aluminium center section	4 = Stainless Steel (npt)	4 = Hardened SST	2 = Acetal	5 = TPE
V = 50.8 mm (2") Standard: stainless steel center section	6 = Ductile Iron (npt)	5 = TPE	4 = Hardened SST	6 = Santoprene
	C = Aluminium (bsp)	6 = Santoprene	5 = TPE	7 = Buna N
	D = Stainless Steel (bsp)	7 = Buna N	6 = Santoprene	8 = Fluoroelastomer
	F = Ductile Iron (bsp)	8 = Fluoroelastomer	7 = Buna N	G = Geolast
		9 = Polypropylene	8 = Fluoroelastomer	
	H = 2 npt Alum Extended	A = PVDF	G = Geolast	
	G = 2 bsp Alum Extended	G = Geolast		

Popular Models

Material	Part Number (NPT Ported)		Part Number (BSP Ported)		Materials for Seats	Materials for Balls	Materials for Diaphragms	Fluid Kit	Air Kit	Air Control**	
	Standard Air Valve	Remote* Air Valve	Standard Air Valve	Remote* Air Valve							
Standard Pumps with Aluminium Center Section											
Aluminium***	DF3311	DG3311	DFC311	DGC311	Stainless Steel	PTFE	PTFE	DOF311	236273	246947	
	DF3341	DG3341	DFC341	DGC341	Stainless Steel	Hardened SST	PTFE	DOF341	236273	246947	
	DF3366	DG3366	DFC366	DGC366	Stainless Steel	Santoprene	Santoprene	DOF366	236273	246947	
	DF3377	DG3377	DFC377	DGC377	Stainless Steel	Buna	Buna	DOF377	236273	246947	
	DF3525	DG3525	DFC525	DGC525	TPE	Acetal	TPE	DOF525	236273	246947	
	DF3555		DFC555		TPE	TPE	TPE	DOF555	236273	246947	
	DF3666	DG3666	DFC666	DGC666	Santoprene	Santoprene	Santoprene	DOF666	236273	246947	
	DF3777	DG3777	DFC777	DGC777	Buna	Buna	Buna	DOF777	236273	246947	
	DF3888	DG3888	DFC888	DGC888	Fluoroelastomer	Fluoroelastomer	Fluoroelastomer	DOF888	236273	246947	
	DF3GGG	DG3GGG	DFCGGG	DGCGGG	Geolast	Geolast	Geolast	DOFGGG	236273	246947	
	DF3911	DG3911	DFC911	DGC911	Polypropylene	PTFE	PTFE	DOF911	236273	246947	
	DF3977	DG3977	DFC977		Polypropylene	Buna	Buna	DOF977	236273	246947	
	Stainless Steel	DF4311	DG4311	DFD311	DGD311	Stainless Steel	PTFE	PTFE	DOF311	236273	246947
		DF4341		DFD341		Stainless Steel	Hardened SST	PTFE	DOF341	236273	246947
DF4366		DG4366	DFD366	DGD366	Stainless Steel	Santoprene	Santoprene	DOF366	236273	246947	
DF4377		DG4377	DFD377	DGD377	Stainless Steel	Buna	Buna	DOF377	236273	246947	
DF4525			DFD525		TPE	Acetal	TPE	DOF525	236273	246947	
DF4666		DG4666	DFD666	DGD666	Santoprene	Santoprene	Santoprene	DOF666	236273	246947	
DF4777		DG4777	DFD777	DGD777	Buna	Buna	Buna	DOF777	236273	246947	
DF4888		DG4888	DFD888	DGD888	Fluoroelastomer	Fluoroelastomer	Fluoroelastomer	DOF888	236273	246947	
DF4GGG		DG4GGG	DFDGGG	DGDGGG	Geolast	Geolast	Geolast	DOFGGG	236273	246947	
DF4911			DFD911		Polypropylene	PTFE	PTFE	DOF911	236273	246947	
Ductile	DF6311		DFF311		Stainless Steel	PTFE	PTFE	DOF311	236273	246947	
	DF6366		DFF366		Stainless Steel	Santoprene	Santoprene	DOF366	236273	246947	
	DF6441		DFF441		Hardened SST	Hardened SST	PTFE	DOF441	236273	246947	
	DF6466	DG6466	DFF466	DGF466	Hardened SST	Santoprene	Santoprene	DOF466	236273	246947	
	DF6525		DFF525		TPE	Acetal	TPE	DOF525	236273	246947	
	DF6666	DG6666	DFF666	DGF666	Santoprene	Santoprene	Santoprene	DOF666	236273	246947	
	DF6A11		DFFA11		PVDF	PTFE	PTFE	DOFA11	236273	246947	
	DF6A88		DFFA88		PVDF	Fluoroelastomer	Fluoroelastomer	DOFA88	236273	246947	
	DF6GGG	DG6GGG	DFFGGG	DGFGGG	Geolast	Geolast	Geolast	DOFGGG	236273	246947	
	Corrosion Resistant Pumps with Stainless Steel Center Section										
Stainless Steel	DV4311		DVD311		Stainless Steel	PTFE	PTFE	DOF311	255061	246947	
	DV4377		DVD377		Stainless Steel	Buna	Buna	DOF377	255061	246947	
	DV4388		DVD388		Stainless Steel	Fluoroelastomer	Fluoroelastomer	DOF388	255061	246947	
	DV4666		DVD666		Santoprene	Santoprene	Santoprene	DOF666	255061	246947	
	DV4888		DVD888		Fluoroelastomer	Fluoroelastomer	Fluoroelastomer	DOF888	255061	246947	
	DV4911		DVD911		Polypropylene	PTFE	PTFE	DOF911	255061	246947	

*Requires CycleFlo or external valve control. ** Air control includes air regulator and filter with gauge. *** Also available in Extended Height version; use DFH or DFG designations

Husky 2150 Metal Pumps



Technical Specifications

Husky 2150 Metal Pumps	Aluminium	Stainless Steel	Ductile Iron
Maximum fluid working pressure	8.4 bar (0.84 MPa - 120 psi)	8.4 bar (0.84 MPa - 120 psi)	8.4 bar (0.84 MPa - 120 psi)
Maximum free flow delivery*	568 l/min (150 gpm)	568 l/min (150 gpm)	568 l/min (150 gpm)
Maximum pump speed	145 cpm	145 cpm	145 cpm
Displacement per cycle**	3.90 liter (1.03 gallon)	3.90 liter (1.03 gallon)	3.90 liter (1.03 gallon)
Maximum suction lift (DF3666)	6.1 m (20 ft) dry	6.1 m (20 ft) dry	6.1 m (20 ft) dry
Maximum size pumpable solids	6.3 mm (0.25 in)	6.3 mm (0.25 in)	6.3 mm (0.25 in)
Maximum diaphragm operating temperature***			
PTFE	104.4°C (220°F)	104.4°C (220°F)	104.4°C (220°F)
Santoprene	82.2°C (180°F)	82.2°C (180°F)	82.2°C (180°F)
Buna-N	82.2°C (180°F)	82.2°C (180°F)	82.2°C (180°F)
TPE	65.5°C (150°F)	65.5°C (150°F)	65.5°C (150°F)
Fluoroelastomer	121.1°C (250°F)	121.1°C (250°F)	121.1°C (250°F)
Geolast	65.5°C (150°F)	65.5°C (150°F)	65.5°C (150°F)
Typical sound level at 4.9 bar (0.49 MPa - 70 psi) air @ 125 cpm	78 dBa	78 dBa	78 dBa
Maximum air consumption	4.9 m ³ /min (175 scfm)	4.9 m ³ /min (175 scfm)	4.9 m ³ /min (175 scfm)
Air pressure operating range	1.4 to 8.4 bar (0.14 to 0.84 MPa / 20 to 120 psi)	1.4 to 8.4 bar (0.14 to 0.84 MPa / 20 to 120 psi)	1.4 to 8.4 bar (0.14 to 0.84 MPa / 20 to 120 psi)
Air inlet size	1/2 npt(f)	1/2 npt(f)	1/2 npt(f)
Fluid inlet & outlet size	51 mm (2 in) npt(f) or bspt(f)	51 mm (2 in) npt(f) or bspt(f)	51 mm (2 in) npt(f) or bspt(f)
Weight	26.3 kg (58 lb) 28.1 kg (62 lb) - Extended	50 kg (111 lb)	59 kg (130 lb)
Weight with stainless steel center section	not available	60 kg (134 lb)	not available
Instruction manual	308368	308368	308368

* Flow rates are with muffler and do not vary based on diaphragm material

** Displacement per cycle may vary based on suction condition, discharge head, air pressure and fluid type

*** Actual pump performance may be affected by prolonged usage at temperature

Husky 2150 Metal Pumps

Performance Charts

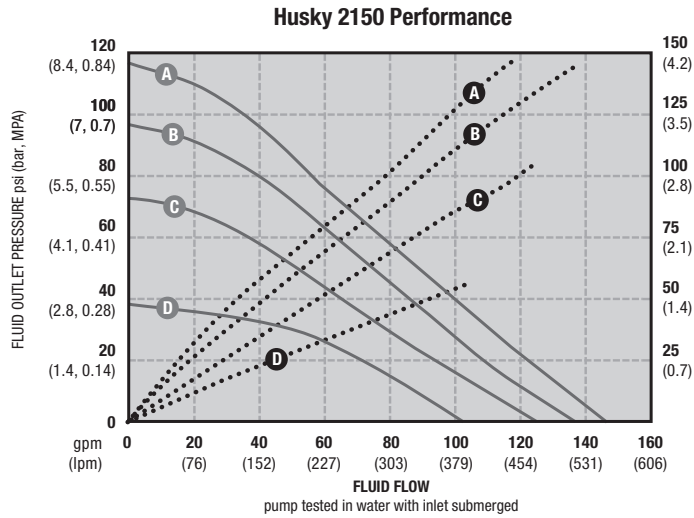

AIR PRESSURE	LEGEND
Ⓐ = at 7 bar (0.7 MPa - 100 psi)	Air Consumption ●●●●
Ⓑ = at 4.8 bar (0.48 MPa - 70 psi)	Fluid Flow ————
Ⓒ = at 2.8 bar (0.28 MPa - 40 psi)	
Ⓓ = at 1.4 bar (0.14 MPa - 20 psi)	

Dimensions

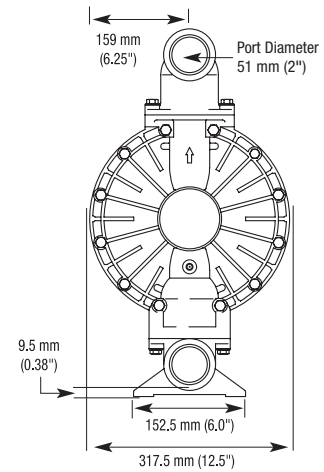
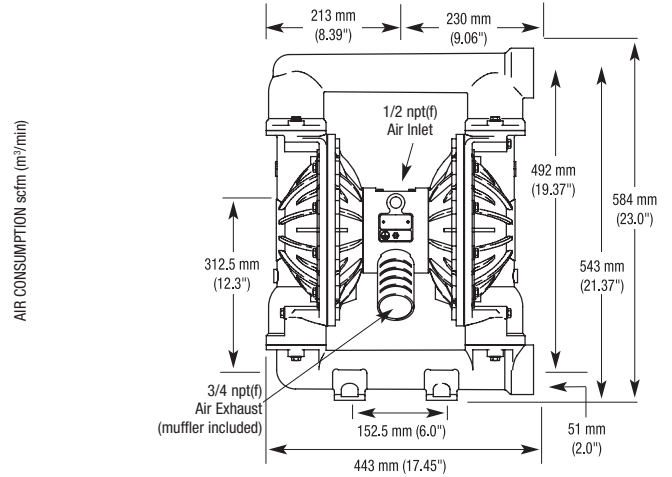

Typical System Drawings

Husky 2150 Above Ground Gravity Feed

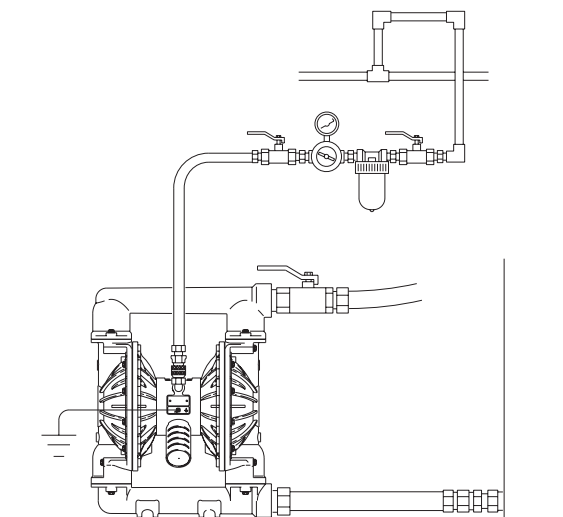

Husky 3300 Plastic Pumps Air-Operated Double Diaphragm

NEW! Husky 3300 Selector Tool

To order a Husky 3300, use the online selector tool at www.graco.com or contact your distributor.

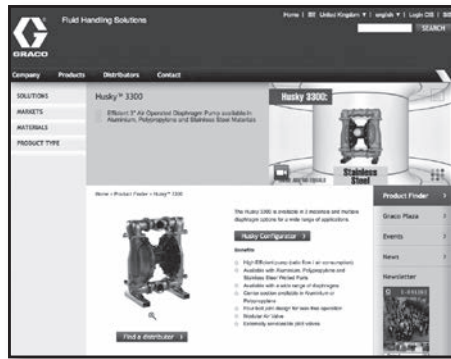

NOTE: Options for seats, check balls, diaphragms, and seals vary.

Example of Product Selector Tool on www.graco.com/process

Pump Configurations

Pump (3 inch ports, 1.059 l/min)	Center Section and Air Valve Material	Air Valve/Monitoring	Fluid Covers and Manifolds
3300P † Polypropylene	Aluminum	A01A	P1 Polypropylene, center flange
		A01G	
	Polypropylene †	P01A	
		P01G	

†: See **ATEX Certifications** below.

Check Valve Seats		Check Valve Balls		Diaphragm		Manifold and Seat Seals		
AC	Acetal	AC	Acetal	BN	Buna-N	---	Models with Buna-N, FKM Fluoroelastomer or TPE seats do not use o-rings.	
AL	Aluminum	BN	Buna-N	CO	Polychloroprene Overmolded			
BN	Buna-N	CR	Polychloroprene Standard	CR	Polychloroprene			
FK	FKM Fluoroelastomer	CW	Polychloroprene Weighted	FK	FKM Fluoroelastomer	BN		Buna
GE	Geolast®	FK	FKM Fluoroelastomer	GE	Geolast	PT		PTFE
PP	Polypropylene	GE	Geolast	PO	PTFE/EPDM Overmolded			
SP	Santoprene®	PT	PTFE	PT	PTFE/Santoprene Two-Piece			
SS	316 Stainless Steel	SP	Santoprene	SP	Santoprene			
TP	TPE	TP	TPE	TP	TPE			

ATEX Certifications

† Pumps with polypropylene fluid or center sections are not ATEX certified.

Husky 3300 Plastic Pumps

Popular Models

Material	Part Number	Materials for Seats	Materials for Balls	Materials for Diaphragms	Air Valve Replacement Kit	Seat Kit	Ball Kit	Diaphragm Kit	O-Ring Kit
Polypropylene	652404	Polypropylene	PTFE	2 pc PTFE	24K857	24K933	24K943	24K905	24K927
Polypropylene	652400	Polypropylene	Santoprene	Santoprene	24K857	24K933	24K944	24K902	24K927
Polypropylene	652423	Santoprene	Santoprene	Santoprene	24K857	24K934	24K944	24K902	24K927
Polypropylene	652414	Stainless Steel	PTFE	2 pc PTFE	24K857	24K935	24K943	24K905	24K927
Polypropylene	652402	Polypropylene	FKM	FKM	24K857	24K933	24K945	24K903	24K927



Technical Specifications

Husky 3300 Plastic Pumps	Polypropylene
Maximum fluid working pressure	7.0 bar (0.7 MPa, 100 psi)
Maximum free flow delivery*	
Standard diaphragms at 7.0 bar (0.7 MPa, 100 psi)	1,059 l/min (280 gpm)
Overmolded diaphragms at 7.0 bar (0.7 MPa, 100 psi)	984 l/min (260 gpm)
Maximum pump speed*	
Standard diaphragms at 7.0 bar (0.7 MPa, 100 psi)	97 cpm
Overmolded diaphragms at 7.0 bar (0.7 MPa, 100 psi)	130 cpm
Maximum suction lift *	2.4 m (8 ft) dry
(varies widely based on ball/seat selection and wear, operating speed, material properties, and other variables)	8.5 m (28 ft) wet
Maximum size pumpable solids	13 mm (0.5 in)
Noise (dBa)***	
Sound Power at 3.4 bar (50 psi) and 50 cpm	99.1 dBa
Sound Power at 8.3 bar (120 psi) and full flow	106.1 dBa
Sound Pressure at 3.4 bar (50 psi) and 50 cpm	91.5 dBa
Sound Pressure at 8.3 bar (120 psi) and full flow	98.2 dBa
Maximum air consumption	7.8 m ³ /min. (275 scfm)
Air pressure operating range	1.4 to 7.0 bar (0.14 to 0.7 MPa, 20 to 100 psi)
Air inlet size	3/4 npt(f)
Fluid inlet/outlet	76.2 mm (3 in) ANSI/DIN flange
Weight	91 kg (200 lb)
Instruction manual	3A0410
Repair/parts manual	3A0411

* Maximum values with water as media at ambient temperature. Water level is approximately 0.9m (3 feet) above pump inlet.

** Startup pressures and displacement per cycle may vary based on suction condition, discharge head, air pressure, and fluid type.

*** Sound power measured per ISO-9614-2. Sound pressure was tested 1 m (3.28 ft) from equipment.

*** Actual pump performance may be affected by prolonged usage at temperature

Husky 3300 Plastic Pumps

Air-Operated Double Diaphragm

Performance Charts

Husky 3300 Performance

Approx. Cycles per Minute

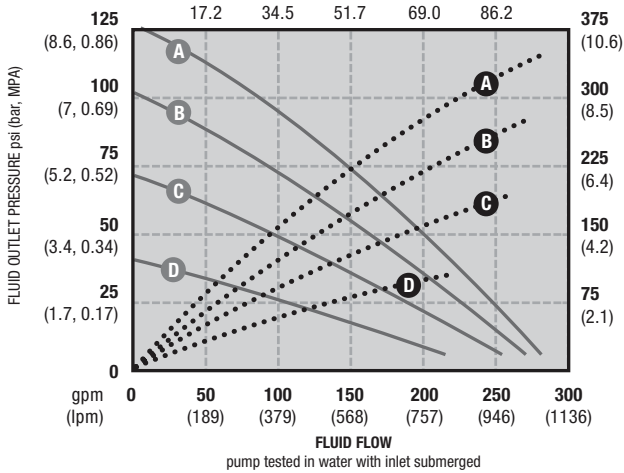

pump tested in water with inlet submerged

AIR PRESSURE	LEGEND
Ⓐ = at 8.3 bar (0.83 MPa - 125 psi)	Air Consumption •••••
Ⓑ = at 7 bar (0.7 MPa - 100 psi)	Fluid Flow ———
Ⓒ = at 4.8 bar (0.48 MPa - 70 psi)	
Ⓓ = at 2.8 bar (0.28 MPa - 40 psi)	

Dimensions

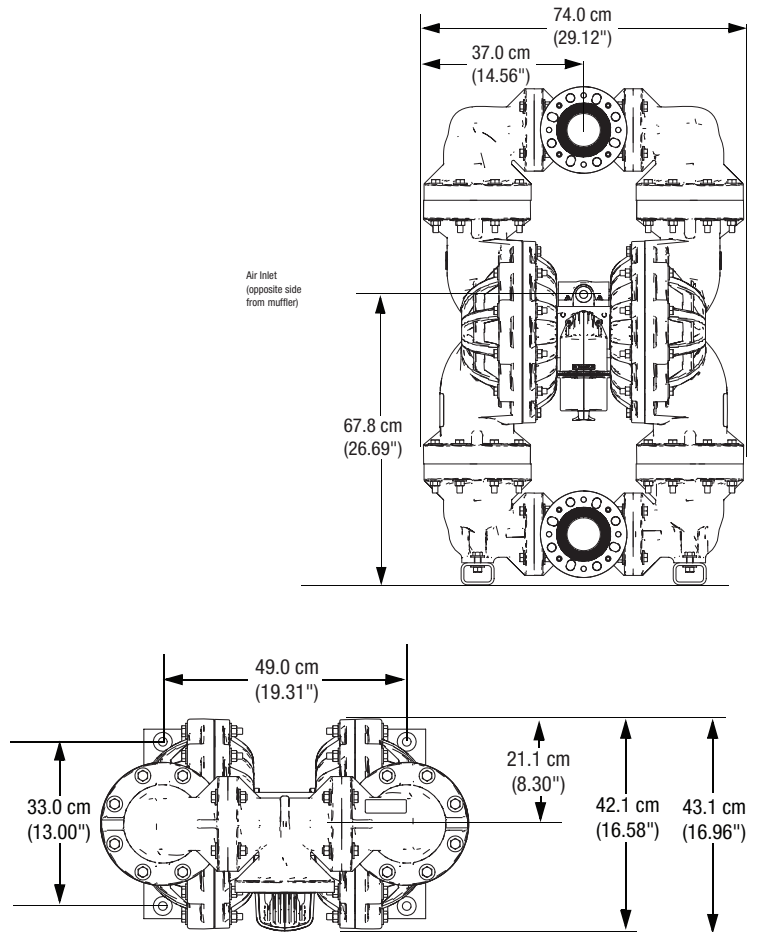

Typical System Drawings

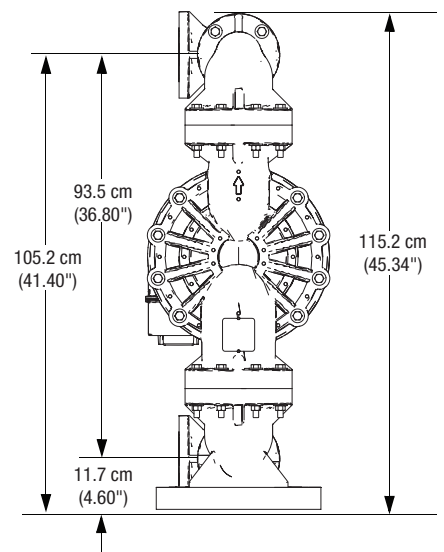
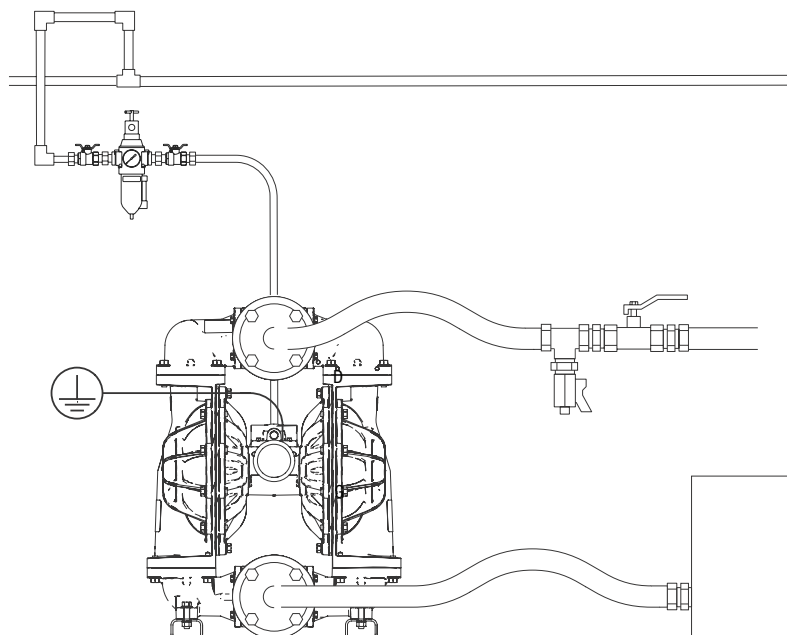

Husky 3300 Metal Pumps Air-Operated Double Diaphragm

NEW! Husky 3300 Selector Tool

To order a Husky 3300, use the online selector tool at www.graco.com or contact your distributor.

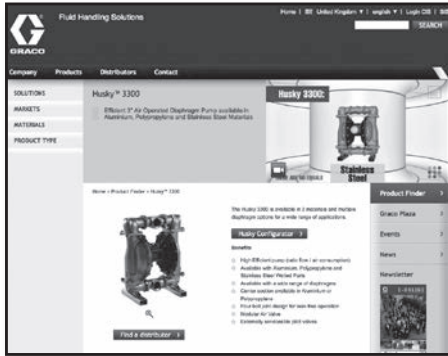

NOTE: Options for seats, check balls, diaphragms, and seals vary.

Example of Product Selector Tool on www.graco.com/process

Pump Configurations

Pump (3 inch ports, 1.135 l/min)	Center Section and Air Valve Material	Air Valve/Monitoring	Fluid Covers and Manifolds
3300A ★ Aluminium 3300S ★ Stainless Steel	Aluminium	A01A	Standard Diaphragms
		A01E	Optional FKM seals with Standard Diaphragms
		A01G	Overmolded Diaphragms
	Polypropylene †	P01A	Standard Diaphragms
		P01G	Overmolded Diaphragms
		A1	Aluminium, center flange, npt
A2	Aluminium, center flange, bspt		
S1	Stainless steel, center flange, npt		
S2	Stainless steel, center flange, bspt		

★: See **ATEX Certifications** below.

Check Valve Seats	Check Valve Balls	Diaphragm	Manifold and Seat Seals
AC Acetal	AC Acetal	BN Buna-N	--- Models with Buna-N, FKM Fluoroelastomer or TPE seats do not use o-rings.
AL Aluminium	BN Buna-N	CO Polychloroprene Overmolded	
BN Buna-N	CR Polychloroprene Standard	CR Polychloroprene	BN Buna
FK FKM Fluoroelastomer	CW Polychloroprene Weighted	FK FKM Fluoroelastomer	
GE Geolast®	FK FKM Fluoroelastomer	GE Geolast	PT PTFE
PP Polypropylene	GE Geolast	PO PTFE/EPDM Overmolded	
SP Santoprene®	PT PTFE	PT PTFE/Santoprene Two-Piece	
SS 316 Stainless Steel	SP Santoprene	SP Santoprene	
TP TPE	TP TPE	TP TPE	

ATEX Certifications

★ 3300A (aluminium) and 3300S (stainless steel) pumps with aluminium center sections are certified:



Popular Models

Material	Part Number	Materials for Seats	Materials for Balls	Materials for Diaphragms	Air Valve Replacement Kit	Seat Kit	Ball Kit	Diaphragm Kit	O-Ring Kit
Aluminium	652002	TPE	Acetal	TPE	24K855	24K932	24K937	24K901	24K909
Aluminium	652046	Geolast	Geolast	Geolast	24K855	24K931	24K939	24K900	24K909
Aluminium	652021	Stainless Steel	PTFE	2 pc PTFE	24K855	24K935	24K943	24K905	24K927
Aluminium	652081	Acetal	PTFE	2 pc PTFE	24K855	24K928	24K943	24K905	24K927
Aluminium	652036	Santoprene	Santoprene	Santoprene	24K855	24K934	24K944	24K902	24K909
Stainless Steel	652804	Stainless Steel	PTFE	2 pc PTFE	24K857	24K935	24K943	24K905	24K927
Stainless Steel	652812	Santoprene	Santoprene	Santoprene	24K857	24K934	24K944	24K902	24K927



Technical Specifications

Husky 2150 Metal Pumps	Aluminum	Stainless Steel
Maximum fluid working pressure with Aluminium Center Section with Polypropylene Center Section	8.6 bar (0.86 MPa, 125 psi)	8.6 bar (0.86 MPa, 125 psi) 7.0 bar (0.7 MPa, 100 psi)
Maximum free flow delivery*		
Standard diaphragms at 8.6 bar (0.86 MPa, 125 psi)	1,135 l/min (300 gpm)	1,135 l/min (300 gpm)
Standard diaphragms at 7.0 bar (0.7 MPa, 100 psi)	1,059 l/min (280 gpm)	1,059 l/min (280 gpm)
Overmolded diaphragms at 8.6 bar (0.86 MPa, 125 psi)	1,022 l/min (270 gpm)	1,022 l/min (270 gpm)
Overmolded diaphragms at 7.0 bar (0.7 MPa, 100 psi)	984 l/min (260 gpm)	984 l/min (260 gpm)
Maximum pump speed*		
Standard diaphragms at 8.6 bar (0.86 MPa, 125 psi)	103 cpm	103 cpm
Standard diaphragms at 7.0 bar (0.7 MPa, 100 psi)	97 cpm	97 cpm
Overmolded diaphragms at 8.6 bar (0.86 MPa, 125 psi)	135 cpm	135 cpm
Overmolded diaphragms at 7.0 bar (0.7 MPa, 100 psi)	130 cpm	130 cpm
Maximum suction lift * (varies widely based on ball/seat selection and wear, operating speed, material properties, and other variables)	2.4 m (8 ft) dry 8.5 m (28 ft) wet	2.4 m (8 ft) dry 8.5 m (28 ft) wet
Maximum size pumpable solids	13 mm (0.5 in)	13 mm (0.5 in)
Noise (dBa)**		
Sound Power at 3.4 bar (50 psi) and 50 cpm	99.1 dBa	99.1 dBa
Sound Power at 8.3 bar (120 psi) and full flow	106.1 dBa	106.1 dBa
Sound Pressure at 3.4 bar (50 psi) and 50 cpm	91.5 dBa	91.5 dBa
Sound Pressure at 8.3 bar (120 psi) and full flow	98.2 dBa	98.2 dBa
Maximum air consumption with Aluminium Center Section with Polypropylene Center Section	9.5 m ³ /min. (335 scfm)	9.5 m ³ /min. (335 scfm) 7.8 m ³ /min. (275 scfm)
Air pressure operating range with Aluminium Center Section with Polypropylene Center Section	1.4 to 8.6 bar (0.14 to 0.86 MPa - 20 to 125 psi)	1.4 to 8.6 bar (0.14 to 0.86 MPa - 20 to 125 psi) 1.4 to 7.0 bar (0.14 to 0.7 MPa - 20 to 100 psi)
Air inlet size	3/4 npt(f)	3/4 npt(f)
Fluid inlet	76.2 mm (3 in) npt or bspt with ANSI/DIN flange	76.2 mm (3 in) npt or bspt
Weight	68 kg (150 lb)	116 kg (255 lb)
Instruction manual	3A0410	3A0410
Repair/parts manual	3A0411	3A0411

* Maximum values with water as media at ambient temperature. Water level is approximately 0.9m (3 feet) above pump inlet.

** Startup pressures and displacement per cycle may vary based on suction condition, discharge head, air pressure, and fluid type.

*** Sound power measured per ISO-9614-2. Sound pressure was tested 1 m (3.28 ft) from equipment.

Husky 3300 Metal Pumps

Performance Charts

Husky 3300 Performance

Approx. Cycles per Minute

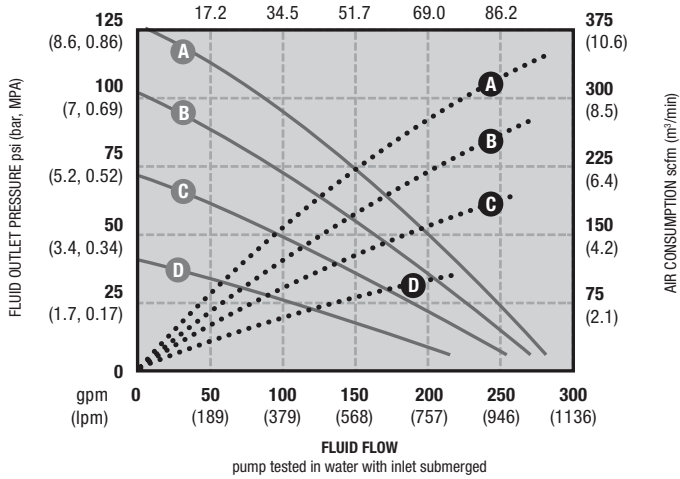

AIR PRESSURE	LEGEND
Ⓐ = at 8.3 bar (0.83 MPa - 125 psi)	Air Consumption •••••
Ⓑ = at 7 bar (0.7 MPa - 100 psi)	Fluid Flow ———
Ⓒ = at 4.8 bar (0.48 MPa - 70 psi)	
Ⓓ = at 2.8 bar (0.28 MPa - 40 psi)	

Typical System Drawings

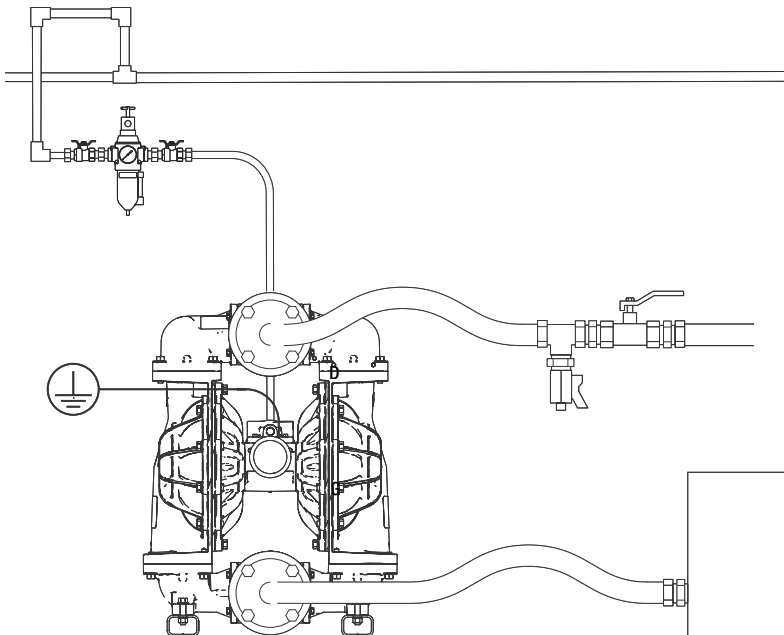

Husky 3300 Metal Pumps

Dimensions

Aluminium

Stainless Steel

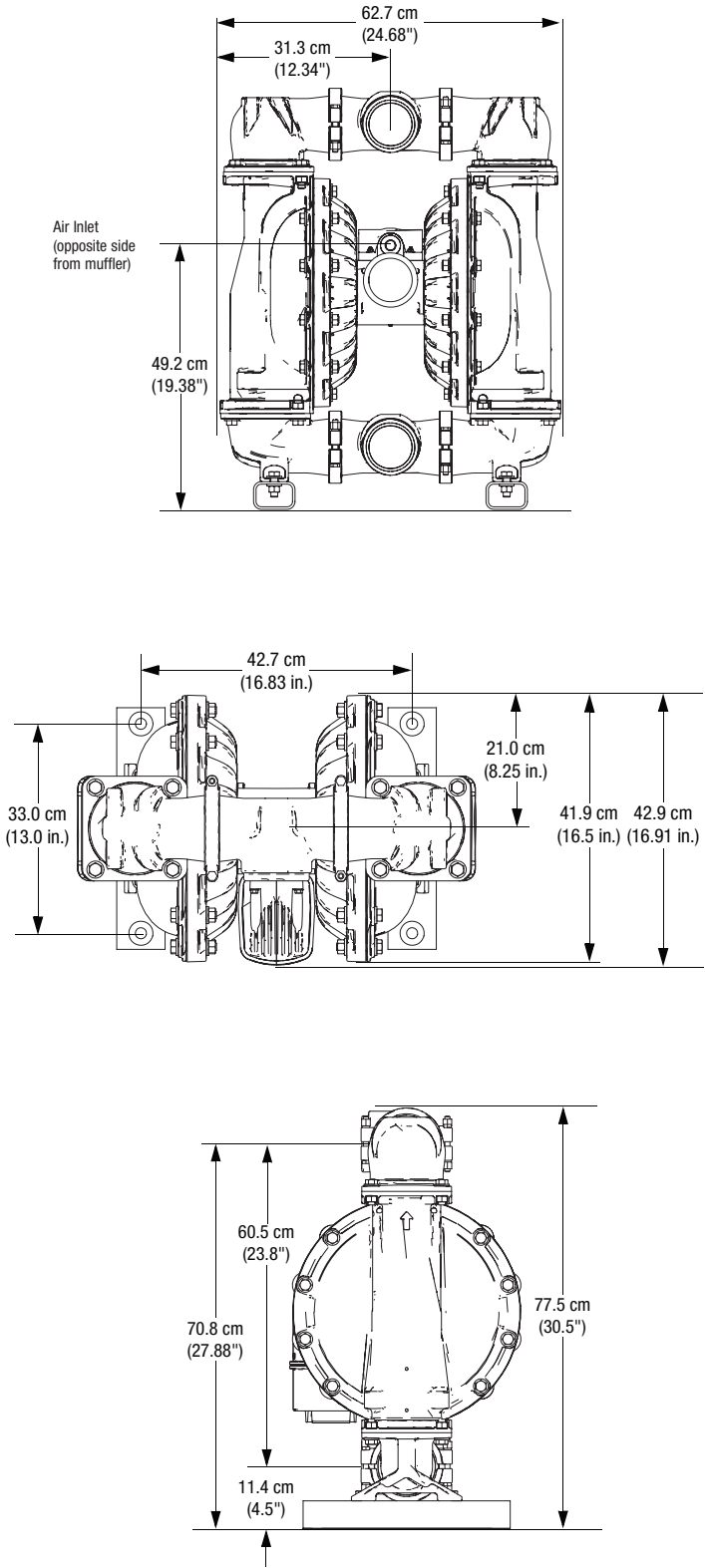
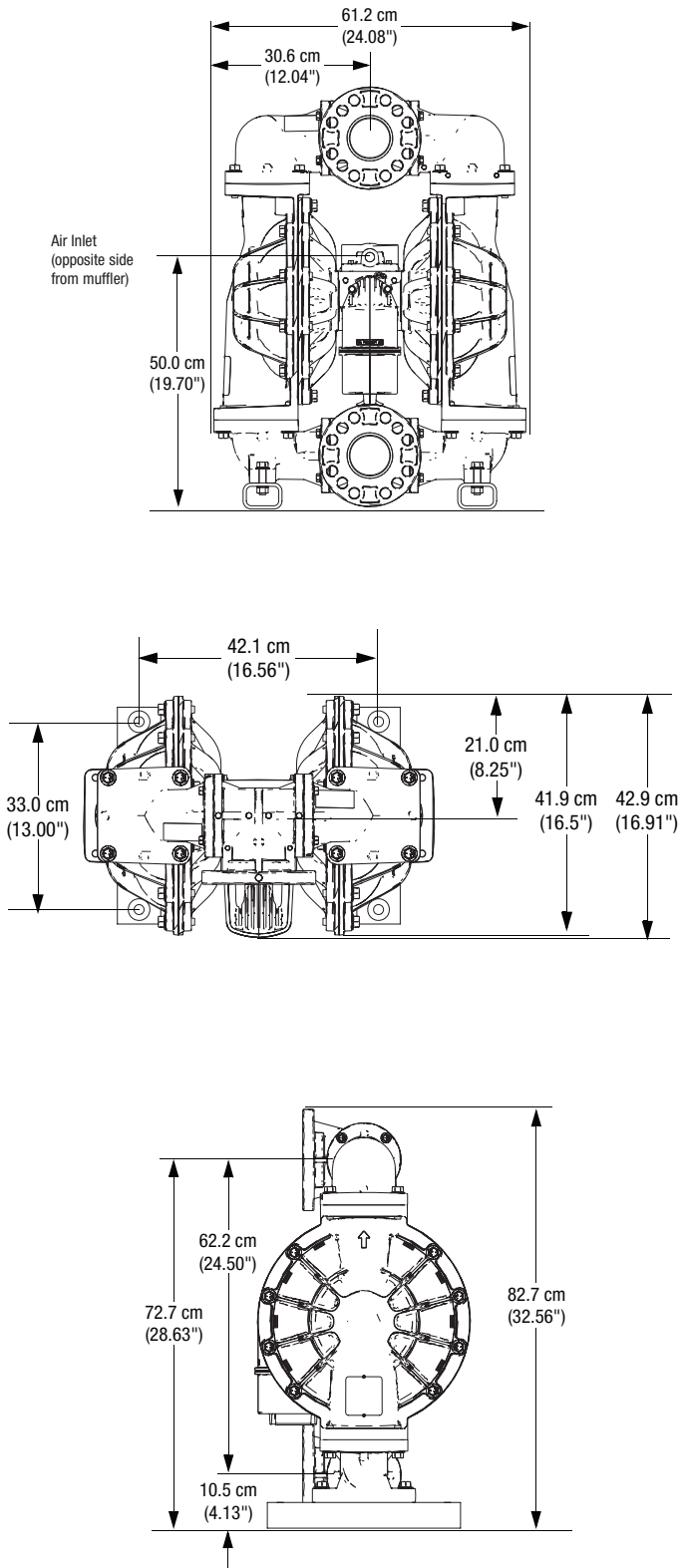

Husky Transfer Pump Packages

208 liter (55 Gallon) Size

Ordering Information

PACKAGE NUMBER	PUMP TYPE	Pump Components				Drum Kit Components			
		PUMP NUMBER*	SEATS	BALLS	DIAPHRAGMS	DRUM KIT NUMBER**	TUBE MATERIAL	TUBE PART NUMBER	EASY OUT SEAL AND MOUNTING BASE
233051	Husky 515 Polypropylene	241565	Polypropylene	PTFE	PTFE	233045	Polypropylene	196096	233073
233052	Husky 515 Acetal	241564	Acetal	PTFE	PTFE	233047	Stainless Steel	196094	233074
233053	Husky 515 Acetal	241564	Acetal	PTFE	PTFE	233046	Aluminium	195095	233074
233054	Husky 716 Aluminium	243305	Acetal	Santoprene	Santoprene	233046	Aluminium	196095	233074
233055	Husky 716 Aluminium	243306	Acetal	Buna	Buna	233046	Aluminium	196095	233074
233056	Husky 716 Aluminium	243307	Acetal	PTFE	PTFE	233046	Aluminium	196095	233074
233057	Husky 716 Stainless Steel	D54311	Stainless Steel	PTFE	PTFE	233048	Stainless Steel	196094	233076

Accessories

- 246946** Air Regulator/Filter
- 208536** Air Line Quick Coupler
- 169970** Quick Coupler Nipple

Husky Transfer Pump Packages

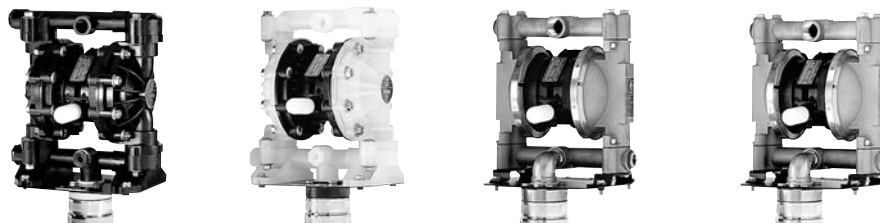

Technical Specifications

Husky 208 liter (55 gal) Transfer Pump	Acetal Husky 515	Polypropylene Husky 515	Aluminium Husky 716	Stainless Steel Husky 716		
Maximum fluid working pressure	7 bar (0.7 MPa - 100 psi)	7 bar (0.7 MPa - 100 psi)	7 bar (0.7 MPa - 100 psi)	7 bar (0.7 MPa - 100 psi)		
Maximum free flow delivery*	57 l/min (15 gpm)	57 l/min (15 gpm)	61 l/min (16 gpm)	61 l/min (16 gpm)		
Maximum pump speed	400 cpm	400 cpm	400 cpm	400 cpm		
Displacement per cycle**	0.15 liter (0.04 gallon)	0.15 liter (0.04 gallon)	0.15 liter (0.04 gallon)	0.15 liter (0.04 gallon)		
Maximum size pumpable solids	2.5 mm (0.094 in)	0.094 in (2.5 mm)	0.094 in (2.5 mm)	0.094 in (2.5 mm)		
Typical sound level at 4.9 bar (0.49 MPa - 70 psi) air @ 50 cpm	67 dBa	67 dBa	67 dBa	67 dBa		
Maximum air consumption	0.672 m ³ /min (28 scfm)	0.672 m ³ /min (28 scfm)	0.672 m ³ /min (28 scfm)	0.672 m ³ /min (28 scfm)		
Air pressure operating range	1.8 to 7 bar (0.18 to 0.7 MPa - 25 to 100 psi)	1.8 to 7 bar (0.18 to 0.7 MPa - 25 to 100 psi)	1.8 to 7 bar (0.18 to 0.7 MPa - 25 to 100 psi)	1.8 to 7 bar (0.18 to 0.7 MPa - 25 to 100 psi)		
Air inlet size	1/4 npt(f)	1/4 npt(f)	1/4 npt(f)	1/4 npt(f)		
Air exhaust port size	3/8 npt(f)	3/8 npt(f)	3/8 npt(f)	3/8 npt(f)		
Fluid inlet size	3/4 npt(f)	3/4 npt(f)	3/4 npt(f)	3/4 npt(f)		
Fluid outlet size	1/2 and 3/4 npt(f)	1/2 and 3/4 npt(f)	3/4 npt(f)	3/4 npt(f)		
Wetted parts (fluid covers and manifolds)	groundable acetal, PTFE	polypropylene, PTFE	Aluminium, stainless steel, PTFE, zinc-plated steel	stainless steel, PTFE		
Pump weight	3.5 kg (7.8 lb)	2.9 kg (6.5 lb)	3.9 kg (8.5 lb)	8.2 kg (18 lb)		
Drum package weight tube material	5.6 kg (12.3 lb) Aluminium	6.5 kg (14.3 lb) stainless steel	4.8 kg (10.5 lb) polypropylene	5.9 kg (13.0 lb) Aluminium	12.5 kg (27.5 lb) stainless steel	
Drum kit weight easy-out seal material	2.0 kg (4.5 lb) Aluminium	2.9 kg (6.5 lb) stainless steel	1.8 kg (4.0 lb) polypropylene	2.0 kg (4.5 lb) acetal	2.9 kg (6.5 lb) acetal	4.3 kg (9.5 lb) stainless steel
Drum package instruction manual	309116	309116	309116	309116		
Instruction manual	308981	308981	308981	308981		

* Flow rates are with muffler and do not vary based on diaphragm material

** Displacement per cycle may vary based on suction condition, discharge head, air pressure and fluid type

Husky Transfer Pump Packages

Dimensions

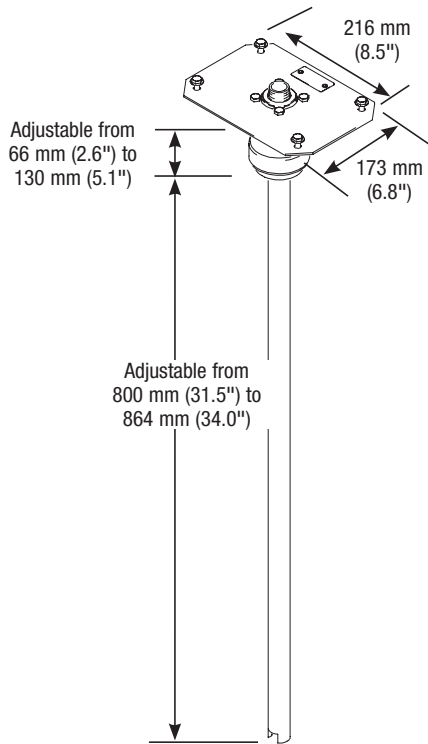

Poly, Acetal and Aluminium Pumps

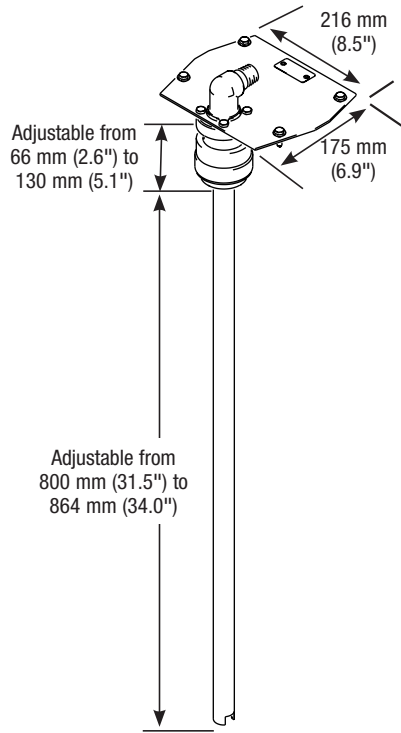

Stainless Steel Pumps

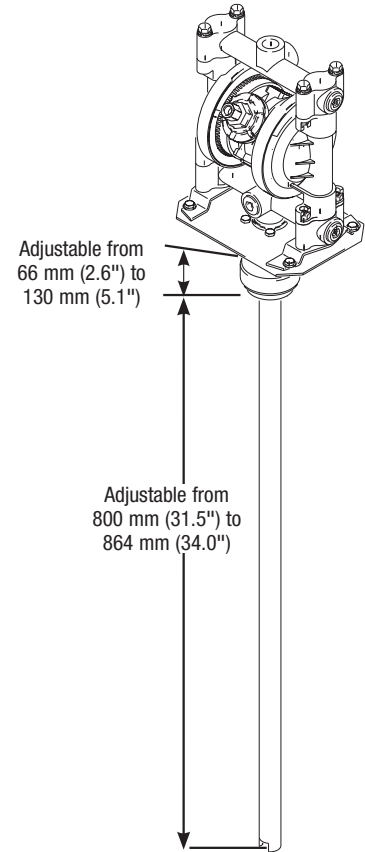

*Overall height depends on pump.
See page 12 or 15 for pump dimensions*

Husky Transfer Pump Packages Pump and Agitator Packages

Ordering Information

PART NUMBER HUSKY 200 L (55 GAL) DISPENSING PACKAGE

231418	Husky 515 acetal pump 241564, stainless steel drum cover 238283, heavy-duty agitator 238157, air-powered drum cover elevator 237746, air controls, hose and dispense valve
231419	Husky 515 acetal pump, stainless steel drum cover, heavy-duty agitator, drum cover elevator

PART NUMBER HUSKY TWISTORK® PACKAGE

238859	Husky 515 D52911 Polypropylene pump mounted on Twistork
238860	Husky 515 D52911 Acetal pump mounted on Twistork



Technical Specifications

Husky 515 on Twistork Agitator

Maximum air input pressure	7 bar (100 psi)
Maximum fluid output pressure	7 bar (100 psi)
Maximum siphon flow rate with 100 cps material	45.4 l/min (12 gpm)
Maximum siphon flow rate with 1000 cps material	4.54 l/min (1.2 gpm)
Air inlet	Quick-coupler, nipple (pin)
Fluid outlet size	3/4 npt(f)
Maximum recommended agitator speed	800 rpm
Agitator air consumption at 400 rpm	0.07 m ³ /min (2.5 scfm)
Agitator air consumption at 800 rpm	0.16 m ³ /min (5.7 scfm)
Pump air consumption at 45.4 l/min (12 gpm)	approximately 0.34 m ³ /min (12 scfm)
Maximum operating temperature	66° C (150° F)
Weight	14.5 kg (32 lb)
Maximum noise level*	85 dB(A)
Instruction manual	308656

* Tested to CAGI-PNEUROP-1969

** See the individual component instruction manuals for service instructions and technical data for the Husky 200 l (55 gal) Dispensing Packages.

Dimensions

Husky 55 gal Dispensing Package

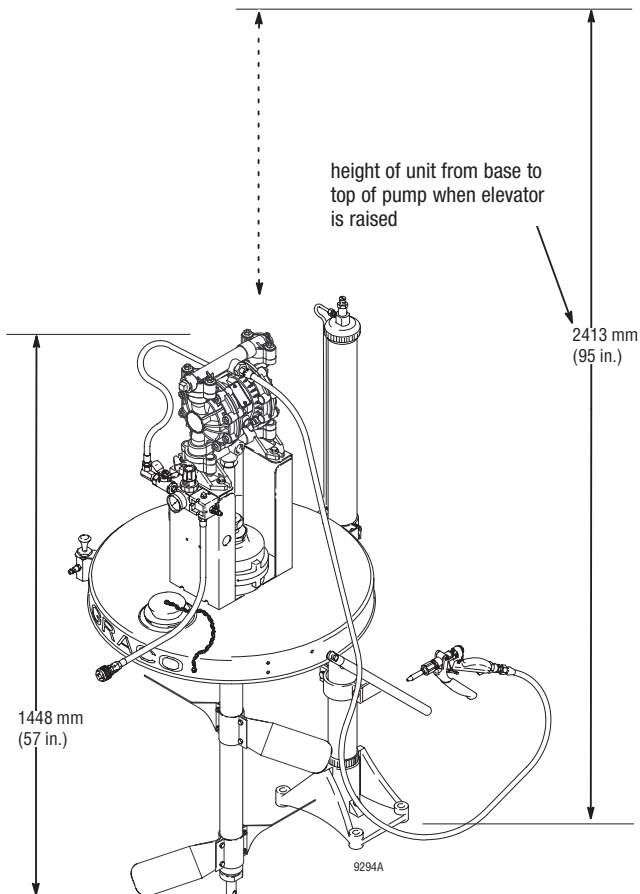

Husky Twistork Package

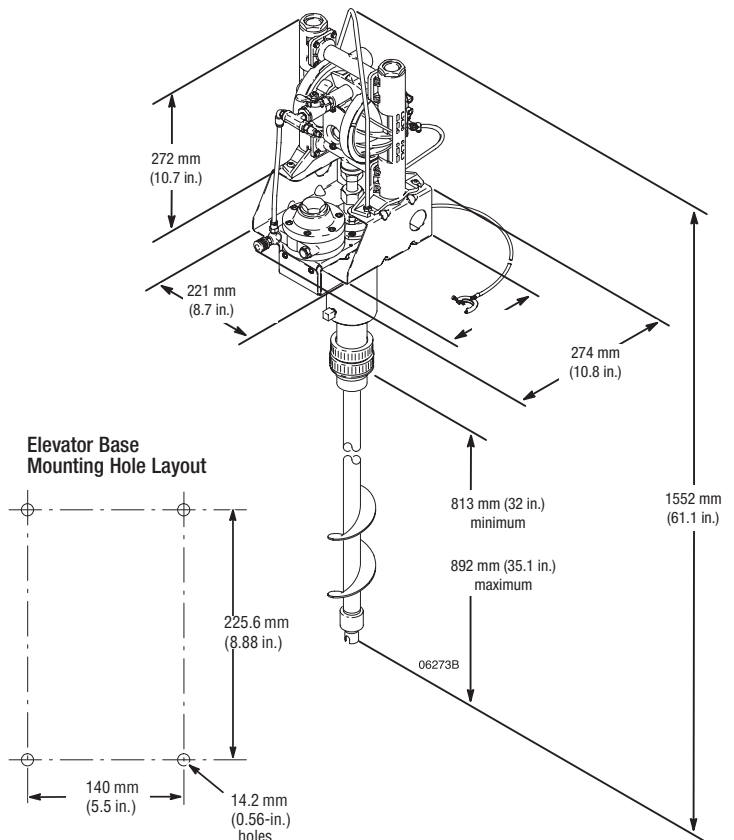

Pump Accessories

Air-Operated Double Diaphragm

Husky 205 Accessories

Part Number

AIR CONTROLS

Regulator / Filter Assembly 1/4" npt(f) (6.35 mm)	246946
Quick Connect Air Coupler 1/4" npt (6.35 mm)	208536
Quick Connect Air Nipple 1/4" npt (6.35 mm) mbe	169970
Air Shut Off Valve 1/4" npt (6.35 mm), bleed type, relieves trapped air downline of valve	110223
Air Runaway Valve (stops pump from cavitating when empty)	224040
Air Muffler (comes with pump)	114174

208 LITER (55-GALLON) SIPHON KITS

Polypropylene Suction Kit (includes siphon hose, tube and connectors)	239142
Acetal Suction Kit (includes siphon hose, tube and connectors)	239143
PVDF Suction Kit (includes siphon hose, tube and connectors)	239144

REMOTE PUMP CONTROLLERS

CycleFlo (cpm rate and batch control) 120V	195264
CycleFlo (cpm rate and batch control) 240V	196706
CycleFlo II (rate controller with solenoid valve) 120V	195265

WALL MOUNTING BRACKET

Wall mounting bracket for Husky 205 pumps	224835
---	--------

Husky 307 Accessories

AIR CONTROLS

Regulator / Filter Assembly 1/4" npt(f) (6.35 mm)	246946
Quick Connect Air Coupler 1/4" npt (6.35 mm)	208536
Quick Connect Air Nipple 1/4" npt (6.35 mm) mbe	169970
Air Shut Off Valve 1/4" npt (6.35 mm), bleed type, relieves trapped air downline of valve	110223
Air Runaway Valve (stop pump from cavitating when empty)	224040
Air Muffler (comes with pump)	112933

208 LITER (55-GALLON) SIPHON KITS

Polypropylene Suction Kit (includes siphon hose, tube and connectors)	235502
Acetal Suction Kit (includes siphon hose, tube and connectors)	235500

REMOTE PUMP CONTROLLERS

Husky 307 pumps are not equipped to run in remote mode	not available
--	---------------

SPLIT MANIFOLD KITS

By varying the manifold kits, pumps can be configured in different ways (one inlet and two outlets, two inlets and one outlet, and two inlets and two outlets, etc), allowing for system flexibility. Pumps need to be ordered separately. One kit is required for each side (top or bottom). See 308439 for details.

Acetal Split Manifold Kit	237211
Polypropylene Split Manifold Kit	237210
Rubber Foot Kit	236452

WALL MOUNTING BRACKET

Wall mounting bracket for Husky 307 pumps	224835
---	--------

Husky 515 and Husky 716 Accessories	Part Number
AIR CONTROLS	
Regulator / Filter Assembly 6.35 mm (1/4" npt(f))	246946
Quick Connect Air Coupler 6.35 mm (1/4" npt)	208536
Quick Connect Air Nipple 6.35 mm (1/4" npt) mbe	169970
Air Shut Off Valve 6.35 mm (1/4" npt), bleed type, relieves trapped air downline of valve	110223
Air Runaway Valve (stop pump from cavitating when empty)	224040
Air Muffler (comes with pump)	112933
Center Section Conversion Kit (converts an old style Husky 715 to a Husky 515/716)	241631
Center Section Conversion Kit (converts an old remote style Husky 715 to a Husky 515/716)	241664
208 LITER (55-GALLON) SIPHON KITS	
Drum Kit (includes "easy out seal" mounting base and siphon tube). Best used with a wall mounted Husky 515 or 716 model. Pump models can be mounted to base, but may require opening bottom inlet. See 309116 for details.	
Mounting Base with a Polypropylene Siphon Tube	233045
Mounting Base with a Aluminium Siphon Tube	233046
Mounting Base with a Stainless Steel Siphon Tube (used with non sst pumps)	233047
Mounting Base with a Stainless Steel Siphon Tube (for sst pump only)	233048
REMOTE PUMP CONTROLLERS	
CycleFlo (cpm rate and batch control) 120V	195264
CycleFlo (cpm rate and batch control) 240V	196706
CycleFlo II (rate controller with solenoid valve) 120V	195265
SPLIT MANIFOLD KITS (HUSKY 515 ONLY)	
By varying the manifold kits, pumps can be configured in different ways (one inlet and two outlets, two inlets and one outlet, and two inlets and two outlets, etc), allowing for system flexibility. Pumps need to be ordered separately. See manual 308951 for details.	
Polypropylene Inlet Manifolds	241240
Polypropylene Outlet Manifolds	241243
Acetal Inlet Manifolds	241241
Acetal Outlet Manifolds	241244
PVDF Inlet Manifolds	241242
PVDF Outlet Manifolds	241245
WALL MOUNTING BRACKET	
Wall mounting bracket for Husky 515 & Husky 716 pumps	224835
MISCELLANEOUS ACCESSORIES	
Duckbill Replacement Parts (urethane) for 515 and 716 Husky Pumps	239754
SURGE SUPPRESSORS	
Surge suppressors are designed to reduce the pulsation caused during pump changeover. The suppressor construction is generally closely matched with the pump's material (Stainless Steel with Stainless Steel, Acetal with Aluminium, etc.) and are available in either an adjustable or automatic version. See 308703 for details.	
Automatic Husky 750, 19.05 mm (3/4")	
Polypropylene (wetted bottom and top housings) with a Buna N bladder	239096
with PTFE bellows	239121
with a Fluoroelastomer bladder	239122

Pump Accessories

Husky 515 and Husky 716 Accessories (continued)

Part Number

SURGE SUPPRESSORS (CONTINUED)

Stainless Steel (wetted bottom and top housings) with a Buna N bladder	239095
with PTFE bellows	239123
with a Fluoroelastomer bladder	239124
Acetal (wetted bottom and top housings) with a Buna N bladder	239094
with PTFE bellows	239125
Adjustable Husky 750, 3/4" (19.05 mm)	
Polypropylene (wetted bottom and top housings) with a Buna N bladder	239091
with PTFE bellows	239129
with a Fluoroelastomer bladder	239130
Stainless Steel (wetted bottom and top housings) with a Buna N bladder	239090
with PTFE bellows	239131
with a Fluoroelastomer bladder	239132
Acetal (wetted bottom and top housings) with a Buna N bladder	239089
with PTFE bellows	239133

PTFE/EPDM OVERMOLDED DIAPHRAGMS - Industrial upgrade kits – includes new airside diaphragm plate

Upgrade kit for 0.5 in (1.27 cm) and 0.75 in (1.905 cm) pump	24N321
--	--------

LEAK DETECTOR

Leak detectors are designed to shut off the pump in the event a diaphragm fails. The leaking material flows out the air section and is captured by the leak detector reservoir. Once the reservoir is filled, a signal is sent that would shut off the pump. These detectors should only be used when a massive failure is allowed.

Polypropylene Housings with PVC Wetted Parts	239080
Shut Off Valve Kit (used in conjunction with 239080)	113870

WALL MOUNTING BRACKET

Wall mounting bracket for Husky 205 pumps	224835
---	--------

Husky 1050, 1590, 2150 Accessories

AIR CONTROLS

Regulator / Filter Assembly 1/2" npt(f) (12.7 mm)	246947
Quick Connect Air Coupler 1/2" npt (12.7 mm)	110199
Quick Connect Air Nipple 1/2" npt (12.7 mm) mbe	110196
Air Shut Off Valve 1/2" npt (12.7 mm), bleed type, relieves trapped air downline of valve	110225
Air Runaway Valve (stop pump from cavitating when empty)	224040
Air Muffler (comes with pump) 1050 pumps	24D642
Air Muffler (comes with pump) 1590 and 2150 pumps	102656
Center Section Conversion Kit (converts an Aluminium center section to sst. Includes air covers).	
Husky 1590	246451
Husky 2150	246452

208 LITER (55-GALLON) SIPHON KIT

Siphon kit is used for drawing fluids from 55-gallon sized containers, through a 2" bung opening	.
Kit comes with carbon steel tube, 8' (2.44 m) polyethylene hose and couplings	222916

REMOTE PUMP CONTROLLERS

CycleFlo (cpm rate and batch control) 120V	195264
CycleFlo (cpm rate and batch control) 240V	196706
CycleFlo II (rate controller with solenoid valve) 120V	195265

DUAL INLET MANIFOLD

Aluminium Husky 1050 only	24D205
---------------------------	--------

CONVERSION KITS

Remote Valve Conversion Kit for Aluminium Husky 1050 only	24D037
Remote Valve Conversion Kit for Polypropylene Husky 1050 only	24D038
Remote Valve Conversion Kit for Conductive Polypropylene Husky 1050 only	24D039

Husky 1050, 1590, 2150 Accessories (continued)

Part Number

SURGE SUPPRESSORS

Surge suppressors are designed to reduce the pulsation caused during pump changeover. The suppressor construction is generally closely matched with the pump's material (Stainless Steel with Stainless Steel, Acetal with Aluminium, etc.) and are available in either an adjustable or automatic version. See 308703 for details.

Automatic Husky 2000, 50.8 mm (2")	
Polypropylene (wetted bottom and top housings) with a Buna N bladder	239092
with PTFE bellows	239128
Stainless Steel (wetted bottom and top housings) with a Buna N bladder	239093
with PTFE bellows	239126
with a Fluoroelastomer bladder	239127
Adjustable Husky 2000, 50.8 mm (2")	
Polypropylene (wetted bottom and top housings) with a Buna N bladder	239087
with PTFE bellows	239136
Stainless Steel (wetted bottom and top housings) with a Buna N bladder	239088
with PTFE bellows	239134
with a Fluoroelastomer bladder	239135

UL PUMPS

For use with leaded and unleaded fuels

Husky 1050 for use with leaded fuel (seat, ball, diaphragm)	647016
Same as 236265, maximum inlet of 3.4 bar (0.3 MPa - 50 psi)	647648

PTFE/EPDM OVERMOLDED DIAPHRAGMS

Industrial upgrade kits – includes new airside diaphragm plate

Upgrade kit for 2.54 cm (1") Husky 1040 pump	289224
Upgrade kit for 2.54 cm (1") Husky 1050 pump	24B626
Upgrade kit for 3.81 cm (1.5") pump	289225
Upgrade kit for 5.08 cm (2") pump	289226

LEAK DETECTOR

Leak detectors are designed to shut off the pump in the event a diaphragm fails. The leaking material flows out the air section and is captured by the leak detector reservoir. Once the reservoir is filled, a signal is sent that would shut off the pump. These detectors should only be used when a massive failure is allowed.

Polypropylene Housings with PVC Wetted Parts	239080
Shut Off Valve Kit (used in conjunction with 239080)	113870

WALL MOUNTING BRACKET

Wall mounting bracket for Husky 1050 pumps - NOT FOR HASTELLOY OR STAINLESS STEEL	24C637
---	--------

MISCELLANEOUS ACCESSORIES

Flange Kits. Used to transition a flanged pump to a npt connection to transition from a threaded connection to a flange. It is recommended that the flange kit be compatible with the pump material.

Polypropylene 24.14 mm (1") flange for Husky 1050 D72XXX pumps. 1" ANSI x 1" npt (f)	239005
Stainless Steel 24.14 mm (1") flange for Husky 1050 D71XXX and D74XXX pumps 1" ANSI x 1" npt (f)	239008
PVDF 24.14 mm (1") flange for Husky 1050 D75XXX pump 1" ANSI x 1" npt (f)	239009
Polypropylene 36.84 mm (1-1/2") flange for Husky 1590 DB2XXX pump 1-1/2" ANSI x 1-1/2" (f)	239006
PVDF 36.84 mm (1-1/2") flange for Husky 1590 DB5XXX pump. 1-1/2" ANSI x 1-1/2" (f)	239010
Polypropylene 48.28 mm (2") flange for Husky 2150 DF2XXX pump. 2" ANSI x 2" (f)	239007
PVDF 48.28 mm (2") flange for Husky 2150 DF5XXX pump 2" ANSI x 2" (f)	239011

Pump Accessories

Husky 3300 Accessories

AIR CONTROLS

Regulator / Filter Assembly 3/4" npt(f) (19.5 mm)	246948
Quick Connect Air Coupler 3/4" npt (19.5 mm) - female	110200
Quick Connect Air Nipple 3/4" npt (19.5 mm) mbe - male	110197
Air Shut Off Valve 3/4" npt (19.5 mm), bleed type, relieves trapped air downline of valve	110226
Air Runaway Valve (stop pump from cavitating when empty)	224040
Air Muffler (comes with pump)	24P932

208 LITER (55-GALLON) SIPHON KITS

Typically, 3" pumps are not used for emptying 208 liter (55-gallon) containers	N/A
--	-----

REMOTE PUMP CONTROLLERS

Husky 3300 pumps are not equipped to run in remote mode	N/A
---	-----

SPLIT MANIFOLD KITS

There are no Husky 3300 with a split manifold option	N/A
--	-----

SURGE SUPPRESSORS

Surge suppressors are designed to reduce the pulsation caused during pump changeover. The suppressor construction is generally closely matched with the pump's material (Stainless Steel with Stainless Steel, Acetal with Aluminium, etc.) and are available either in adjustable or automatic version. See 308703 for details.

Automatic Husky 2000, 50.8 mm (2 in)	
Polypropylene (wetted bottom and top housings) with a Buna N bladder	239092
with PTFE bellows	239128
Manual Husky 2000, 50.8 mm (2 in)	
Polypropylene (wetted bottom and top housings) with a Buna N bladder	239087
with PTFE bellows	239136

DATATRACK KITS*

Aluminium Pulse Count & Runaway Protection	24K861
Aluminium Pulse Count Only	24B795
Polypropylene Pulse Count & Runaway Protection	24K862
Polypropylene Pulse Count Only	24B794

* Kit includes replacement airvalve compatible with solenoid

EP Series Hose Pumps

Positive Displacement Hose Pumps

Three steps to choosing your pump:

- 1. Choose your pump size to meet your flow requirement**
Use the Performance Charts below to choose your Pump Model.
- 2. Choose your pump speed range**
Using the Selection Charts, go to your Model Number and find the Gear Ratio for your desired pump speed.
- 3. Choose your hose & hose barb materials to meet your material properties**
Keep moving down the Selection Charts to select your hose material and your hose barb material.



Step 1: Performance Charts & Technical Specifications

Pump Model	EP2006	EP2013
Maximum flow (130 rpm)	2.0 l/min (0.5 gpm)	7.9 l/min (2.1 gpm)
Capacity (flow per revolution)	0.015 l/rev (0.004 gal/rev)	0.06 l/rev (0.016 gal/rev)
Maximum discharge pressure	13.8 bar (200 psi)	13.8 bar (200 psi)
Hose inner diameter	6 mm	13 mm
Port size	1/2 in male NPT	1/2 in male NPT

EP2006 Performance

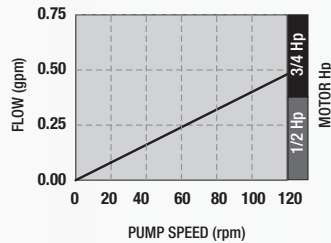

EP2013 Performance

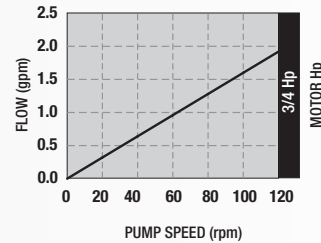

Pump Model	EP3019	EP4029
Maximum flow (130 rpm)	23.6 l/min (6.2 gpm)	73.8 l/min (19.5 gpm)
Capacity (flow per revolution)	0.182 l/rev (0.048 gal/rev)	0.568 l/rev (0.15 gal/rev)
Maximum discharge pressure	13.8 bar (200 psi)	13.8 bar (200 psi)
Hose inner diameter	19 mm	29 mm
Port size	3/4 in male NPT	1-1/4 in male NPT

EP3019 Performance

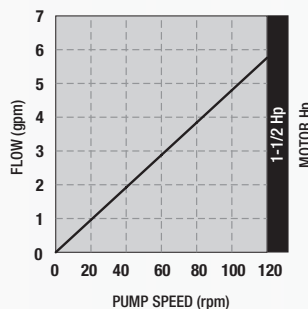

EP4029 Performance

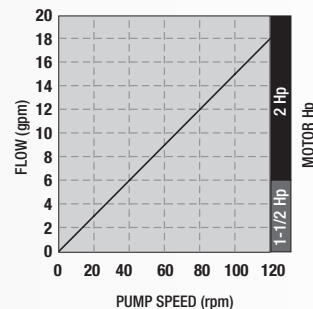

EP Series Hose Pumps

Graco Assembled Complete Pumps

Step 2: Choose Your Pump Speed Range

Model	EP2006			EP2013		
	Max flow @ 130 rpm - l/min	2.0			7.9	
Flow/Rev - liter	0.015			0.060		
Motor/Gear Speed Range	Low	Mid	High	Low	Mid	High
Motor Consumption - HP (kW)	0.33 (0.25)	0.5 (0.37)	-	0.33 (0.25)	0.75 (0.56)	-
Pump Speed @ 50 Hz - rpm *	9	29	-	9	29	-
Flow Rate @ 50 Hz - l/min *	0.14	0.43	-	0.53	2.58	-
Maximum Working Pressure - bar (psi)	13.8 (200)			13.8 (200)		
Maximum Suction Lift - m (ft)	8.9 (29)			8.9 (29)		
Operation Manual	3A1938			3A1938		
Repair-Parts Manual	3A1940			3A1940		
Pump Inlet / Outlet Size	1/2" male NPT			1/2" male NPT		

* Using a VFD you can run the motor at a different frequency. This will change the rpm of the pump. For example you increase rpm (& flow) by 20% if you run the motor at 60 Hz instead 50 Hz.

Step 3: Choose Your Hose & Hose Barb Materials

Hose Material	Hose Barb Material	EP2006			EP2013		
		Natural Rubber	316 SST	24L104	24L118	-	24L188
	Hastelloy-C	-	-	-	-	-	-
Nitrile	316 SST	24L107	24L121	-	24L191	24L205	-
	Hastelloy-C	24L108	24L122	-	24L192	24L206	-
EPDM	316 SST	24L100	24L114	-	24L184	24L198	-
	Hastelloy-C	24L101	24L115	-	24L185	24L199	-
CSM	316 SST	24L105	24L119	-	24L189	24L203	-
	Hastelloy-C	24L106	24L120	-	24L190	24L204	-

EP Series Hose Pumps

Graco Assembled Complete Pumps

Model	EP3019			EP4029		
Max flow @ 130 rpm - l/min	23.6			73.8		
Flow/Rev - liter	0.182			0.568		
Motor/Gear Speed Range	Low	Mid	High	Low	Mid	High
Motor Consumption - HP (kW)	1 (0.75)	1.5 (1.12)	-	1.5 (1.12)	2 (1.50)	2 (1.50)
Pump Speed @ 50 Hz - rpm *	15	42	-	19	43	76
Flow Rate @ 50 Hz - l/min *	2.67	7.5	-	10.7	24.9	43.2
Maximum Working Pressure - bar (psi)	13.8 (200)			13.8 (200)		
Maximum Suction Lift - m (ft)	8.9 (29)			8.9 (29)		
Operation Manual	3A1938			3A1938		
Repair-Parts Manual	3A1939			3A1939		
Pump Inlet / Outlet Size	3/4" male NPT			1-1/4" male NPT		

Hose Material	Hose Barb Material	EP3019			EP4029		
Natural Rubber	316 SST	24L546	24L560	-	25L028	25L042	25L056
	Hastelloy-C	-	-	-	-	-	-
Nitrile	316 SST	24L549	24L563	-	25L031	25L045	25L059
	Hastelloy-C	24L550	24L564	-	25L032	25L046	25L060
EPDM	316 SST	24L542	24L556	-	25L024	25L038	25L052
	Hastelloy-C	24L543	24L557	-	25L025	25L039	25L053
CSM	316 SST	24L547	24L561	-	25L029	25L043	25L057
	Hastelloy-C	24L548	24L562	-	25L030	25L044	25L058

EP Series Hose Pumps

Graco Pump Kits with roller not installed (fully assembled pumps with the roller shipped in a separate package)

Step 2: Choose Your Pump Speed Range

Model	EP2006			EP2013		
Max flow @ 130 rpm - l/min	2.0			7.9		
Flow/Rev - liter	0.015			0.060		
Motor/Gear Speed Range	Low	Mid	High	Low	Mid	High
Motor Consumption - HP (kW)	0.33 (0.25)	0.5 (0.37)	-	0.33 (0.25)	0.75 (0.56)	-
Pump Speed @ 50 Hz - rpm *	9	29	-	9	29	-
Flow Rate @ 50 Hz - l/min *	0.14	0.43	-	0.53	2.58	-
Maximum Working Pressure - bar (psi)	13.8 (200)			13.8 (200)		
Maximum Suction Lift - m (ft)	8.9 (29)			8.9 (29)		
Operation Manual	3A1938			3A1938		
Repair-Parts Manual	3A1940			3A1940		
Pump Inlet / Outlet Size	1/2" male NPT			1/2" male NPT		

* Using a VFD you can run the motor at a different frequency. This will change the rpm of the pump. For example you increase rpm (& flow) by 20% if you run the motor at 60 Hz instead 50 Hz.

Step 3: Choose Your Hose & Hose Barb Materials

Hose Material	Hose Barb Material	EP2006			EP2013		
Natural Rubber	316 SST	24L374	24L388	-	24L458	24L472	-
	Hastelloy-C	-	-	-	-	-	-
Nitrile	316 SST	24L377	24L391	-	24L461	24L475	-
	Hastelloy-C	24L378	24L392	-	24L462	24L476	-
EPDM	316 SST	24L370	24L384	-	24L454	24L468	-
	Hastelloy-C	24L371	24L385	-	24L455	24L469	-
GSM	316 SST	24L375	24L389	-	24L459	24L473	-
	Hastelloy-C	24L376	24L390	-	24L460	24L474	-

EP Series Hose Pumps

Graco Pump Kits with roller not installed

Model	EP3019			EP4029		
Max flow @ 130 rpm - l/min	23.6			73.8		
Flow/Rev - liter	0.182			0.568		
Motor/Gear Speed Range	Low	Mid	High	Low	Mid	High
Motor Consumption - HP (kW)	1 (0.75)	1.5 (1.12)	-	1.5 (1.12)	2 (1.50)	2 (1.50)
Pump Speed @ 50 Hz - rpm *	15	42	-	19	43	76
Flow Rate @ 50 Hz - l/min *	2.67	7.5	-	10.7	24.9	43.2
Maximum Working Pressure - bar (psi)	13.8 (200)			13.8 (200)		
Maximum Suction Lift - m (ft)	8.9 (29)			8.9 (29)		
Operation Manual	3A1938			3A1938		
Repair-Parts Manual	3A1939			3A1939		
Pump Inlet / Outlet Size	3/4" male NPT			1-1/4" male NPT		

Hose Material	Hose Barb Material	EP3019			EP4029		
Natural Rubber	316 SST	24L630	24L644	-	25L094	25L108	25L122
	Hastelloy-C	-	-	-	-	-	-
Nitrile	316 SST	24L633	24L647	-	25L097	25L111	25L125
	Hastelloy-C	24L634	24L648	-	25L098	25L112	25L126
EPDM	316 SST	24L626	24L640	-	25L090	25L104	25L118
	Hastelloy-C	24L627	24L641	-	25L091	25L105	25L119
GSM	316 SST	24L631	24L645	-	25L095	25L109	25L123
	Hastelloy-C	24L632	24L646	-	25L096	25L110	25L124

EP Series Hose Pumps

Ordering & Mounting Information

Hose Pumps with No Motor Drive (fully assembled pumps with customer supplied motor drive)

Hose Material	Hose Barb Material	EP2006	EP2013	EP3019	EP4029
Natural Rubber	316 SST	24M739	24M767	24M795	24M820
	Hastelloy-C	-	-	-	-
Nitrile	316 SST	24M742	24M770	24M798	24M823
	Hastelloy-C	24M743	24M771	24M799	24M824
EPDM	316 SST	24M735	24M763	24M791	24M816
	Hastelloy-C	24M736	24M764	24M792	24M817
CSM	316 SST	24M740	24M768	24M796	24M821
	Hastelloy-C	24M741	24M769	24M797	24M822

Mounting a Non-Graco Motor (to mount a non-graco motor and gearbox to a bare EP Hose Pump)

EP Series Pump Size	Hollow Bore Shaft Diameter A	Bolt Circle Diameter B	Flange Pilot Diameter C	Mounting Hole Thread Size D
EP2	20 mm	100 mm	80 mm	M6
EP3	30 mm	130 mm	110 mm	M8
EP4	35 mm	165 mm	130 mm	M10

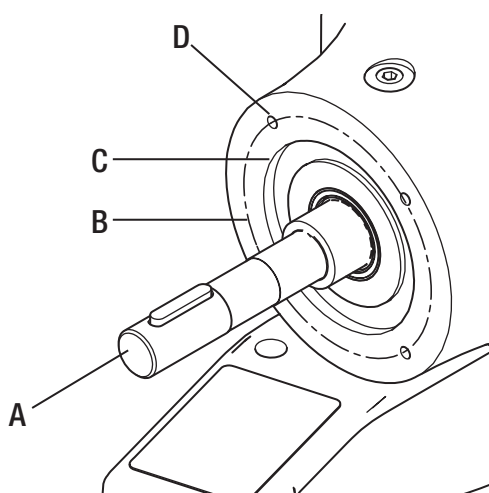

Motor mounting dimensions for EP2 Pumps

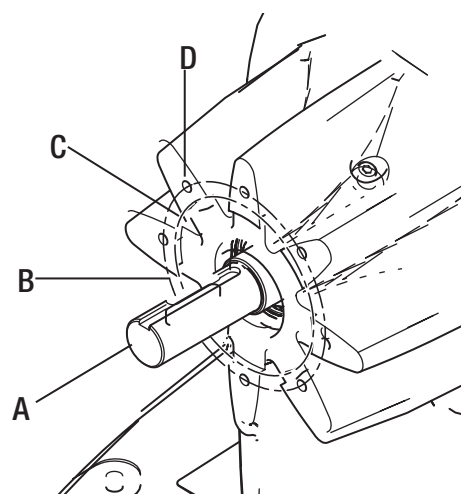

Motor mounting dimensions for EP3 & EP4 Pumps

Kits and Replacement Hoses Ordering Information

Replacement Hose Kits*

	EP2006	EP2010	EP2013	EP3016	EP3019	EP4025	EP4029
Natural Rubber	24K482	24K492	24K502	24K522	24K532	24K542	24K552
Nitrile	24K484	24K494	24K504	24K524	24K534	24K544	24K554
EPDM	24K483	24K493	24K503	24K523	24K533	24K543	24K553
CSM	24K487	24K497	24K507	24K527	24K537	24K547	24K557

* Includes 2 clamps

VFDs (Variable Frequency Drives)

Hp	Input Voltage	Output Voltage	Used with Pump	Part Number
0.5	120 or 240 VAC (1 Phase)	240 VAC (3 Phase)	EP2006	16K905
0.5	208-240 VAC (1 or 3 Phase)	208-240 VAC (3 Phase)	EP2006	16K906
1	120 or 240 VAC (1 Phase)	240 VAC (3 Phase)	EP2010, EP2013	16K907
1	208-240 VAC (1 or 3 Phase)	208-240 VAC (3 Phase)	EP2010, EP2013	16K908
1.5	120 or 240 VAC (1 Phase)	240 VAC (3 Phase)	EP3016, EP3019	16K909
1.5	208-240 VAC (1 or 3 Phase)	208-240 VAC (3 Phase)	EP3016, EP3019	16K910
2	208-240 VAC (1 or 3 Phase)	208-240 VAC (3 Phase)	EP4025, EP4029	16K911
2	400-480 VAC (3 Phase)	400-480 VAC (3 Phase)	EP4025, EP4029	16K912

Hose Pump Lubricant

Description	Part Number
Glycerin Based Hose Lube - 1 liter (1 quart)	24K692
Glycerin Based Hose Lube - 3.8 liter (1 gallon)	24K694
Glycerin Based Hose Lube - 208 liter (55 gallon) drum	24M435

EP2 requires 250 mL (8 oz) of hose lube; EP3 requires 1 l (1 qt) of hose lube; EP4 requires 2 liter (1/2 gallon) of hose lube
 Factory fill is glycerin, shipped in a separate bottle

Other

Description	Part Number
"Band-It" Clamp Tool	24L497

EP Series Hose Pumps

Dimensions

EP2 Hose Pumps

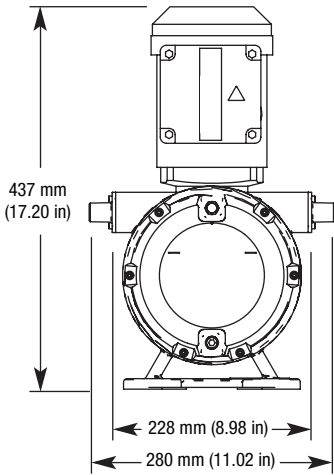

EP3 Hose Pumps

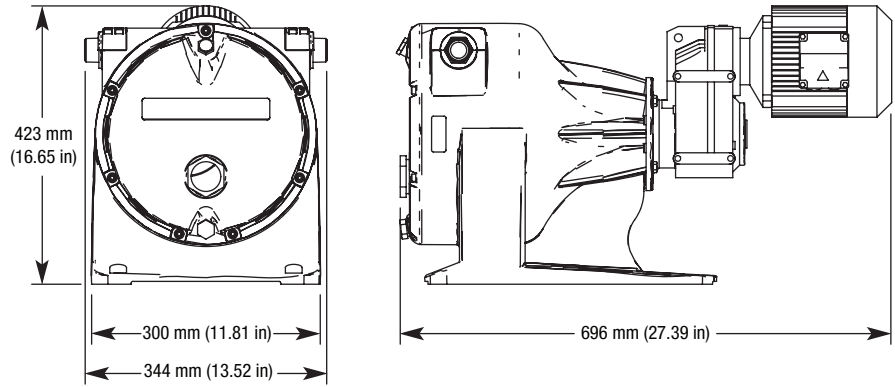

EP4 Hose Pumps

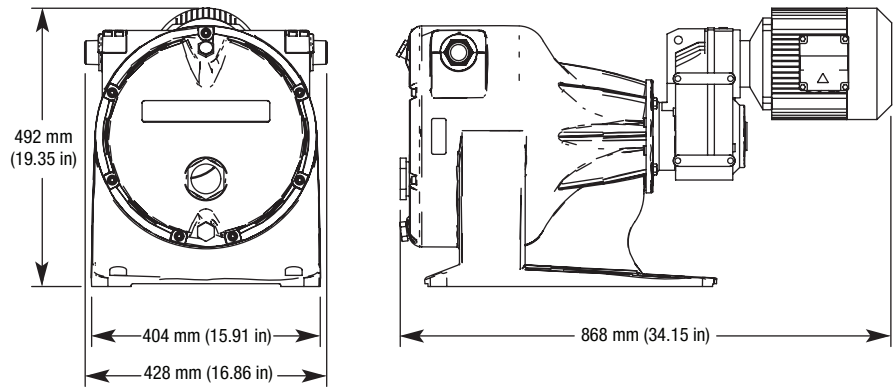

Wall Mount Hydra-Clean Package

PACKAGE ORDER NO.	247550	247552	247554	258665	Pump Package
Air Motor Part No.	N34DN0	N65DN0	N65DN0	N65DN0	
Pump Lower Part No.	247599	241648	687055	24B923	
Pump Construction	SST	SST	SST	SST	
Standard Seal Repair Kit	247881	222880	See manual 311825	24C162	
Standard Seal Construction	PTFE/ CF-PTFE	UHMWPE/ CF-PTFE	UHMWPE/ CF-PTFE	UHMWPE/ CF-PTFE	
Optional Seal Repair Kits	207581	222875	222845	237713	
Optional Seal Construction	PTFE	UHMWPE/PTFE	UHMWPE/PTFE	UHMWPE/PTFE	
Brochure	338026	338026	338026	338026	
Instruction Manual	312585	312585	312585	312585	

Cart Mount Hydra-Clean Package

Package Order No.	247549	247551	247553	258664	Pump Package
Air Motor Part No.	N34DN0	N65DN0	N65DN0	N65DN0	
Pump Lower Part No.	247599	241648	687055	24B923	
Pump Construction	SST	SST	SST	SST	
Standard Seal Repair Kit	247881	222880	See manual 311825	24C162	
Standard Seal Construction	PTFE/ CF-PTFE	UHMWPE/ CF-PTFE	UHMWPE/ CF-PTFE	UHMWPE/ CF-PTFE	
Optional Seal Repair Kits	207581	222875	222845	237713	
Optional Seal Construction	PTFE	UHMWPE/PTFE	UHMWPE/PTFE	UHMWPE/PTFE	
Brochure	338026	338026	338026	338026	
Instruction Manual	312585	312585	312585	312585	

Drum Mount Hydra-Clean Package

Package Order No.	206515	Pump Package
Air Motor Part No.	207352	
Pump Lower Part No.	224344	
Pump Construction	SST	
Standard Seal Repair Kit	224402	
Standard Seal Construction	UHMWPE/Polychloroprene	
Optional Seal Construction	UHMWPE/PTFE	
Instruction Manual	306817	

Hydra-Clean Pressure Washers

Technical Specifications

Part Number	Pump Package	Max. Working Pressure bar (MPa - psi)	Max. Air Input Pressure bar (MPa - psi)	Fluid Flow at 60 cpm l/min (gpm)	Vol. per Cycle cc (oz)	Air Inlet Size	Fluid Inlet Size	Fluid Outlet Size*	Flyer	Manual
247549	12:1 Cart Mount	86 (8.6 - 1250)	7 (0.7 - 100)	33.0 (8.7)	550 (18.6)	3/4 npt(f)	1"	3/8"	338026	312585
247550	12:1 Wall Mount	86 (8.6 - 1250)	7 (0.7 - 100)	33.0 (8.7)	550 (18.6)	3/4 npt(f)	1"	3/8"	338026	312585
247551	23:1 Cart Mount	157 (15.7 - 2275)	7 (0.7 - 100)	34.7 (9.2)	580 (19.6)	3/4 npt(f)	1"	3/8"	338026	312585
247552	23:1 Wall Mount	157 (15.7 - 2275)	7 (0.7 - 100)	34.7 (9.2)	580 (19.6)	3/4 npt(f)	1"	3/8"	338026	312585
247553	30:1 Cart Mount	211 (21.1 - 3065)	7 (0.7 - 100)	25.9 (6.8)	430 (14.5)	3/4 npt(f)	1"	3/8"	338026	312585
247554	30:1 Wall Mount	211 (21.1 - 3065)	7 (0.7 - 100)	25.9 (6.8)	430 (14.5)	3/4 npt(f)	1"	3/8"	338026	312585
258664	45:1 Cart Mount	310 (31.0 - 4500)	7 (0.7 - 100)	17.4 (4.6)	290 (9.8)	3/4 npt(f)	1"	3/8"	338026	312585
258665	45:1 Wall Mount	310 (31.0 - 4500)	7 (0.7 - 100)	17.4 (4.6)	290 (9.8)	3/4 npt(f)	1"	3/8"	338026	312585
206515	10:1 Drum Mount	125 (12.5 - 1800)	12.5 (1.2 - 180)	11.4 (3.0)	189 (6.4)	1/2 npt(f)	1/2"	3/4"	—	306817

*Includes two outlet ports per unit

Accessories

Guns and Wands

- 247879 Replacement gun/wand
- 15T283 Brass/stainless spray gun
- 15T282 Stainless steel spray gun
- 15T279 32" stainless steel wand
- 15T280 10" stainless steel wand
- 247880 Gun stainless steel connections
- 247622 Gun and suction tube holder

Hoses

- 214959 1" x 2 m (6 ft) inlet hose
- 247878 3/8" x 15 m (50 ft) outlet hose: 310 ar (4500 psi)

Other

- 15T284 60 mesh inlet strainer with 1" NPT(f) connection
- 191635 0 mesh inlet strainer with 1" NPT(f) connection

Stainless Steel Tips

Part Number	Orifice Size mm (in)	Fan Width Angle at 3 bar (0.03 MPa - 40 psi)	Capacity at 68.9 bar (6.89 MPa - 1000 psi) l/min (gpm)
805534	0.51 (0.020)	40°	3.78 (1.00)
805538*	0.76 (0.030)	40°	5.68 (1.50)
805542	0.89 (0.035)	40°	6.62 (1.75)
805549*	1.14 (0.045)	25°	8.52 (2.25)
805561	1.52 (0.060)	25°	11.36 (3.00)
805566*	1.65 (0.065)	40°	12.30 (3.25)
805569	1.78 (0.070)	25°	13.25 (3.50)
805574	1.91 (0.075)	40°	14.20 (3.75)
805575*	2.03 (0.080)	0°	15.14 (4.00)
805584	2.28 (0.090)	15°	17.03 (4.50)
805587	2.54 (0.100)	0°	18.93 (5.00)

Other orifice sizes and fan widths available from Graco, contact a sales representative for more information.

Hydra-Clean Pressure Washers

Dimensions

Wall Mount Package 247550

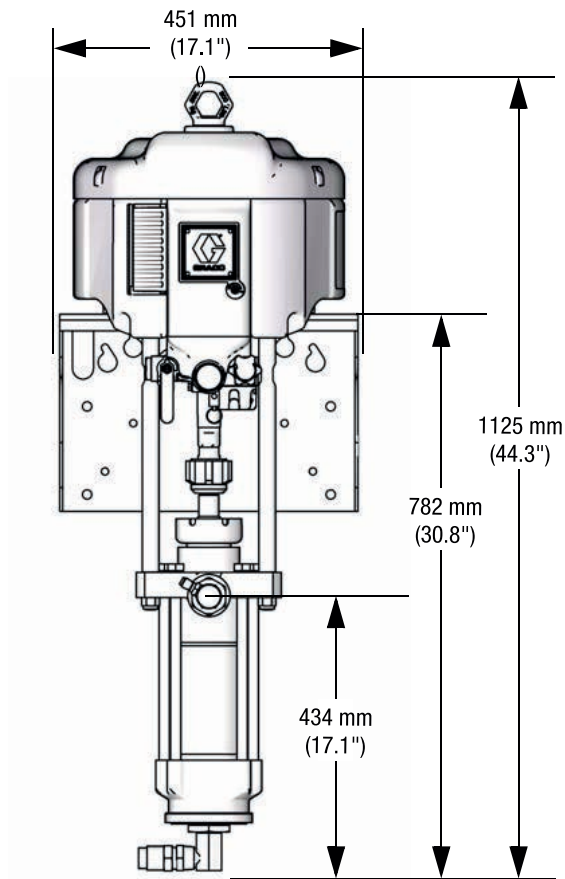

Cart Mount Package 247549

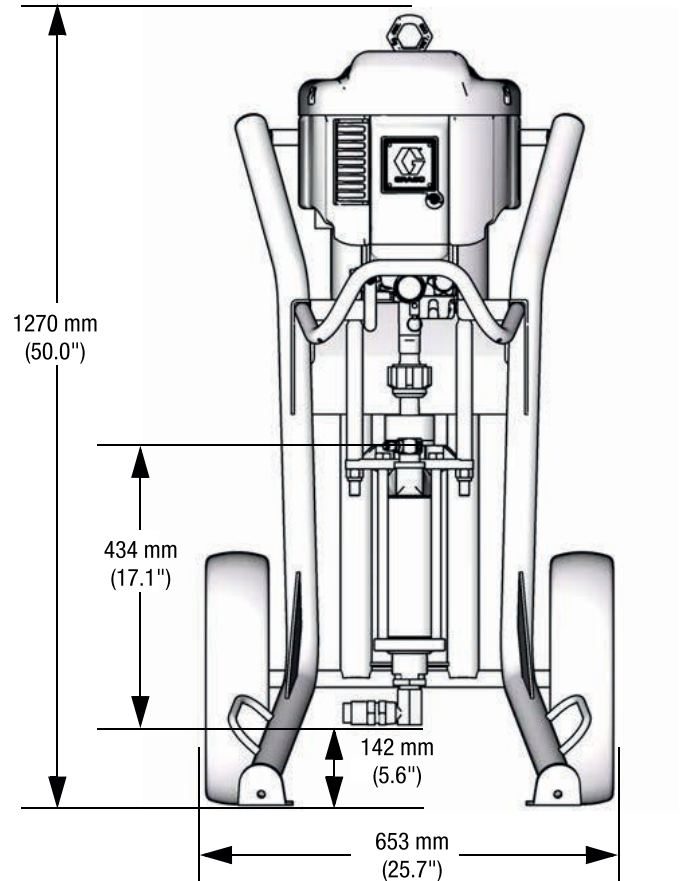

Refer to manual 312585 for additional package dimensions

CycleFlo and CycleFlo II Solenoid Pump Controllers

Ordering Information

- 195264 CycleFlo Pneumatic pump controller, 120V
- 196706 CycleFlo Pneumatic pump controller, 240V
- 195265 CycleFlo II Pneumatic pump controller, 120V
- 309003 CycleFlo Instruction Manual
- 309004 CycleFlo II Instruction Manual

Product Selector

Highlighted areas indicate the different sizes of remote pumps and available materials of construction for seats, balls and diaphragms that can be used with the CycleFlo and CycleFlo II controller.

PUMP SIZE (AIR MOTOR TYPE AND MATERIAL)	WETTED PARTS	SEATS	BALLS	DIAPHRAGM
2 = 6.35 mm (1/4") Remote: polypropylene center section	1 = Acetal (npt)	0 = Seat with ball	1 = PTFE	1 = PTFE
4 = 12.7 mm (1/2") Remote: polypropylene center section	2 = Poly (npt)	2 = Acetal	2 = Acetal	5 = TPE
4 = 19.05 mm (3/4") Remote: polypropylene center section	3 = Aluminium (npt)	3 = Stainless Steel	3 = Stainless Steel	6 = Santoprene
8 = 25.4 mm (1") Remote: Aluminium center section	4 = Stainless Steel (npt)	4 = Hardened SST	4 = Hardened SST	7 = Buna N
S = 25.4 mm (1") Remote: stainless steel center section	5 = PVDF (npt)	5 = TPE	5 = TPE	8 = Fluoroelastomer
C = 38.1 mm (1-1/2") Remote: Aluminium center section	6 = Ductile Iron (npt)	6 = Santoprene	6 = Santoprene	G = Geolast
U = 38.1 mm (1-1/2") Remote: stainless steel center section	A = Acetal * (bsp)	7 = Buna N	7 = Buna N	
G = 50.8 mm (2") Remote: Aluminium center section	B = Poly * (bsp)	8 = Fluoroelastomer	8 = Fluoroelastomer	
W = 50.8 mm (2") Remote: stainless steel center section	C = Aluminium (bsp)	9 = Polypropylene	9 = Polypropylene	
	D = Stainless Steel (bsp)	A = PVDF	A = PVDF	
	E = PVDF (bsp)	G = Geolast	G = Geolast	
	F = Ductile Iron (bsp)	B = SST with viton seal		
	H = 2 npt Alum Extended	C = Santoprene with viton seal		
	G = 2 bsp Alum Extended	D = Urethane Duckbill		

Mounting Dimensions

CycleFlo

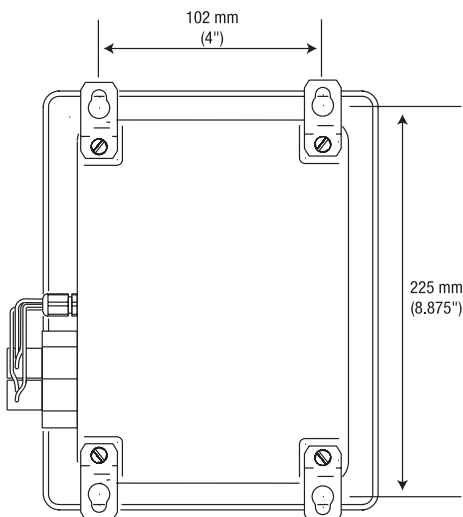

CycleFlo II

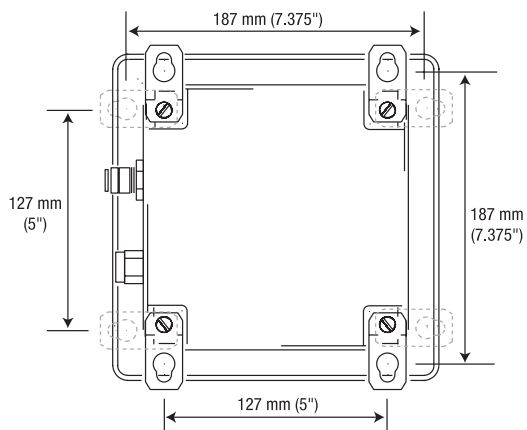

How To Determine The Best Remote Pump:

1. Configure the best seat, ball and diaphragm combination, as well as fluid wetted parts, based on material compatibility and application requirements.
 - If the material is a mild acid, the choice could be a DX2911.
2. Determine dispense time and volume accuracy.
 - In two minutes, 185 liter (50 gallons) need to be dispensed $\pm 5\%$ accuracy
3. Use the displacement volume chart below to choose the pump size with an outlet volume/cycle that is most closely divisible into your required flow.*
 - Husky 1590 produces 1.85 l/cycle (.5 gal/cycle)
 - Husky 2150 produces 3.8 l/cycle (1.03 gal/cycle)

	Husky 205	Husky 515	Husky 716	Husky 1050	Husky 1590	Husky 2150
Volume/cycle	1/4"	1/2"	3/4"	1"	1-1/2"	2"
Cubic centimeters (cc)	46	150	150	644	1960	3000
Liters	0.05	0.15	0.15	0.64	1.96	3.9
Grams (assumes s.g =1.0)	46	150	150	644	1960	3900
Kilograms (kg)	0.05	0.15	0.15	0.64	1.96	3.9
Gallons	0.01	0.04	0.04	0.17	0.50	1.03
Quarts	0.05	0.16	0.16	0.68	2.0	4.12
Pints	0.1	0.32	0.32	1.36	4.0	8.24
Ounces	1.54	5.12	5.12	21.8	64.0	131.84
Cubic inch	2.77	9.24	9.24	39.27	115.5	237.93

4. Determine the number of cycles required. Calculate the dispense time by dividing required flow by outlet volume per cycle.
 - Husky 1590 = $185 \text{ l} / 1.85 \text{ l/cycle}$ (50 gal / 0.5 gal/cycle) = 100 cycles
 - Husky 2150 = $185 \text{ l} / 3.8 \text{ l/cycle}$ (50 gal/1.03 gal/cycle) = 48.55 cycles
5. Determine if cycle output is within the dispense accuracy required.
 - Husky 2150 requires 48.55 cycles to pump 185 liter (50 gallons). Only full cycles are possible, so either 48 or 49 cycles can be counted. At the 48 cycle count, dispense would be 183 liter (49.44 gallons). At the 49 cycle count, dispense would be 187 liter (50.47 gallons).
 - Husky 1590 requires 100 cycles to pump 185 liter (50 gallons). No partial cycles required.
6. After determining the best size, use the pump ordering matrix to decide which remote center section is most suitable for the application – DC2911 (Aluminium center section) or DU5911 (stainless steel center section).
 - Since a mild acid is being pumped, DC2911, an Aluminium center section would be the best choice.

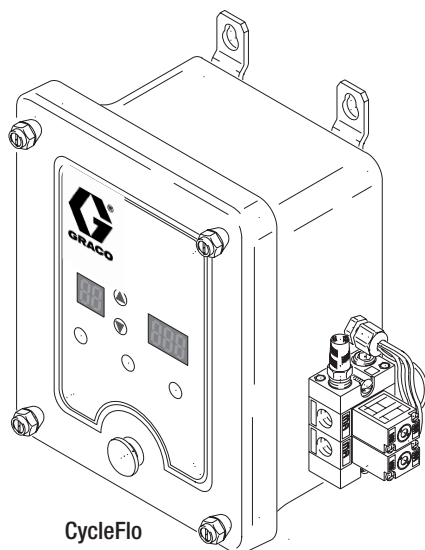

CycleFlo

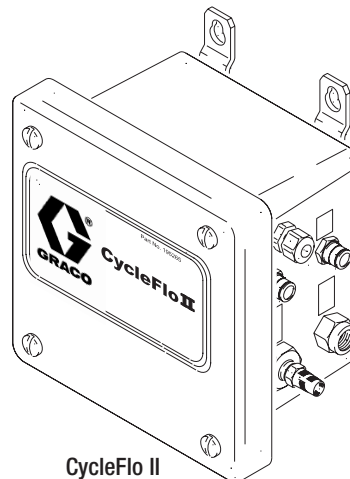

CycleFlo II

* Displacement values are estimates based on average running conditions.

Fast-Flo 1:1

Air-Operated Piston Transfer Pumps

Ordering Information

PART NUMBER	CONSTRUCTION	PACKING
226940	Drum/CS/SST (UL, CE)	T&L
226941	Drum/CS/SST (UL, CE)	PE
226942	Drum/SST (UL, CE)	PE
226943	Stubby/CS/SST (UL, CE)	L
226944	Stubby/CS/SST (UL, CE)	PE
226945	Stubby/SST (UL, CE)	PE
226946	Drum/CS/SST (CE)	T
237129	Drum/SST (CE)	T
237130	Stubby/CS (CE)	L
237131	Stubby/CS (CE)	T
237132	Stubby/CS (CE)	T
237133	Drum/CS (CE)	L
237134	Drum/CS (CE)	T



N = Neoprene SST = 304 Stainless Steel
 L = Leather CS = Carbon Steel
 T = PTFE PE = Polyethylene

Technical Specifications

Fast-Flo 1:1	Priming Piston
Maximum fluid working pressure	12.4 bar (1.24 MPa - 180 psi)
Maximum pump speed	100 cpm
Pump cycles per liter	6.5
Maximum air input pressure	12.4 bar (1.24 MPa - 180 psi)
Maximum operating temperature	49°C (120°F)
Typical sound level	72 dBa
Air inlet	1/4 npt (f)
Fluid outlet	3/4 npt (f)
Weight	9.07 kg (20 lbs) Drum; 4.99 kg (11 lbs) Stubby
Instruction Manual	307427

Performance Charts

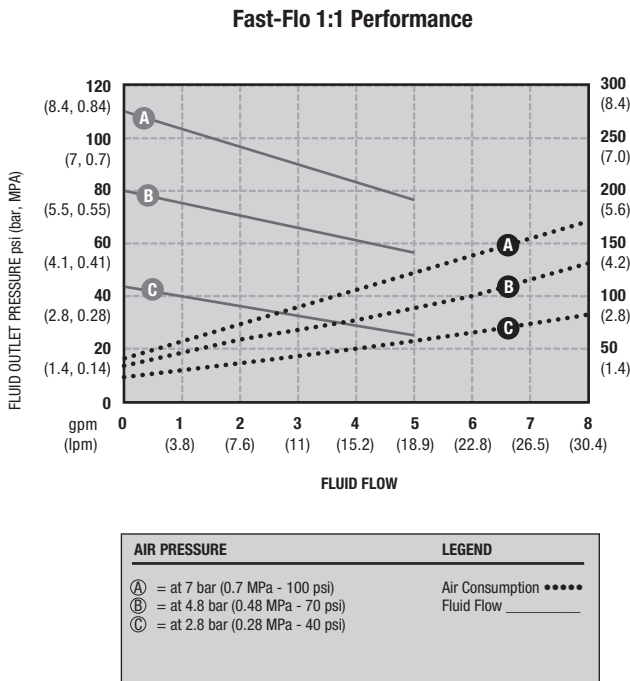

Dimensions

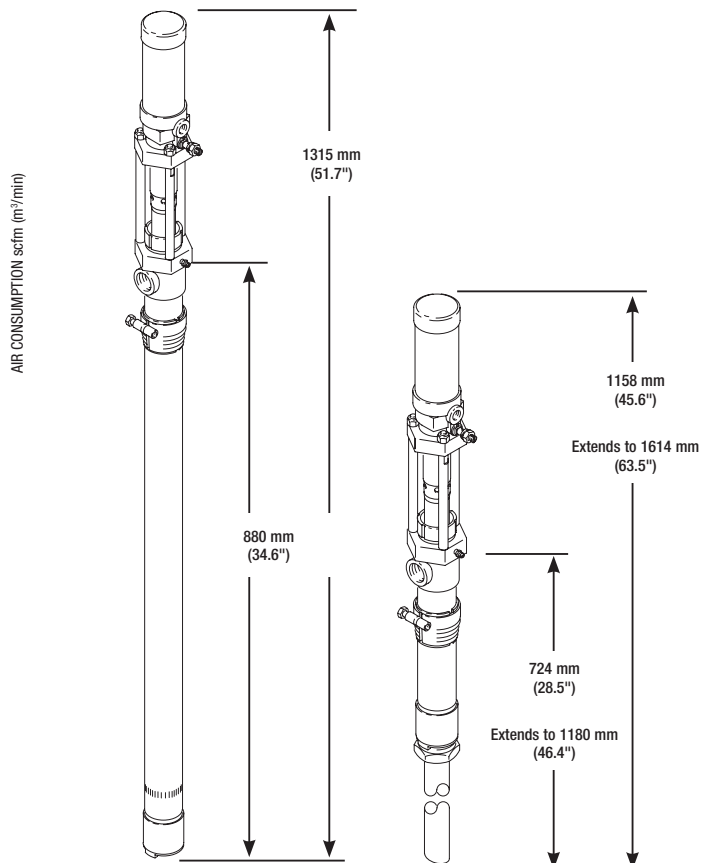

Piston Pumps for Ink Applications

Ink Applications

Ordering Information and Technical Specifications

Piston Pumps with Sealed Wet Cup

Ink Pump Package	Series	Ratio	DataTrak	Remote DataTrak	Power Source	Displacement Pump Size	Maximum Air or Hydraulic Input Pressure bar (MPa - psi)	Maximum Fluid Working Pressure bar (MPa - psi)
258744	A	14:1			Air	500 cc	7.0 (0.7-100)	97 (9.7-1400)
258745	A	14:1	x		Air	500 cc	7.0 (0.7-100)	97 (9.7-1400)
258746	A	14:1		x	Air	500 cc	7.0 (0.7-100)	97 (9.7-1400)
258747	A	23:1			Air	200 cc	7.0 (0.7-100)	159 (15.9-2300)
258748	A	23:1	x		Air	200 cc	7.0 (0.7-100)	159 (15.9-2300)
258749	A	23:1		x	Air	200 cc	7.0 (0.7-100)	159 (15.9-2300)
258750	A	26:1			Air	500 cc	7.0 (0.7-100)	179 (17.9-2600)
258751	A	26:1	x		Air	500 cc	7.0 (0.7-100)	179 (17.9-2600)
258752	A	26:1		x	Air	500 cc	7.0 (0.7-100)	179 (17.9-2600)
258753	A	1.6:1			Hydraulic Oil	500 cc	103 (10-1500)	159 (15.9-2300)

Motor Conversion Kits

Part No.	Description
24C743	To install an L200CM Check-Mate displacement pump on an existing King air motor
24C744	To install an L500CM Check-Mate displacement pump on an existing King air motor
24D625	To install an L500CM Check-Mate displacement pump on an existing Viscount II hydraulic motor

Piston Pumps with Sealed Wet Cup

Stroke length	
Pneumatic	120.65 mm (4.75 in)
Hydraulic	119.13 mm (4.69 in)
Maximum fluid operating temperature	82.3° C (180° F)
Air or Hydraulic Inlet Size	3/4 npt (f)
Fluid outlet size	200 cc displacement pump: 1 npt (f)
	500 cc displacement pump: 1-1/2 npt (f)
Maximum pump speed	60 cpm

(Do not exceed maximum recommended speed of fluid pump, to prevent premature pump wear)

Other

Part No.	Description
222780	Floor Stand Kit See manual 307971

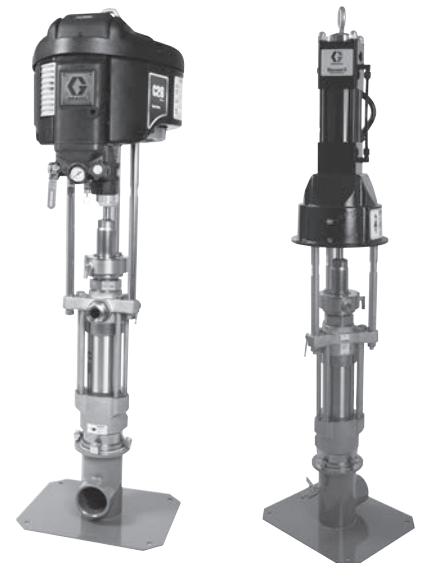

Pneumatic

Hydraulic

Piston Pumps for Ink Applications

Ink Applications

Ordering Information and Technical Specifications

Name of Pump	Senator 19:1	Viscount II 1900	Bulldog 31:1	Viscount II 3100
Lower size	800	800	800	800
Maximum fluid pressure	131 bar (13.1 MPa-1900 psi)	131 bar (13.1 MPa-1900 psi)	213 bar (21.3 MPa-3100 psi)	213 bar (21.3 MPa-3100 psi)
Maximum motor inlet pressure	6.9 bar (0.69 MPa-100 psi (air))	31 bar (3.1 MPa-450 psi (oil))	6.9 bar (0.69 MPa-100 psi (air))	51.7 bar (5.1 MPa-750 psi (oil))
Flow rate @ 60 cpm	10.6 l/min (2.8 gpm)	10.6 l/min (2.8 gpm)	10.6 l/min (2.8 gpm)	10.6 l/min (2.8 gpm)
Cfm or gpm required per gallon	24 cfm	16.2 l/min (4.3 gpm)	32 cfm	16.2 l/min (4.3 gpm)
Fluid pump outlet size	1" npt (f)	1" npt (f)	1" npt (f)	1" npt (f)
Motor inlet size	3/4" npt (f)	3/4" npt (f)	3/4" npt (f)	3/4" npt (f)
Weight of pump	73 kg (160 lb)	80 kg (177 lb)	73 kg (160 lb)	80 kg (177 lb)
Instruction manual	308351	308351	308351	308351

Bin Supply	Senator 19:1	Viscount II 1900	Bulldog 31:1	Viscount II 3100
Pump	246941	246938	246940	246938
Air controls: FRL, 1/2"	217072		217072	
Air run away control, 3/4"	224040		224040	
Air speed control, 1/2"(f)	510441		510441	
Floor stand (3" inlet)	222780	222780	222780	222780
Hydraulic controls*		236865		236865
Outlet hydraulic hose connector 1"(m) x 1-1/2"(f), 100 bar (1500 psi) rated		Not included		Not included

Misc. Information	Senator 19:1	Viscount II 1900	Bulldog 31:1	Viscount II 3100
Pump lower section	246939	246939	246939	246939
Ram plate replacement seals	165601	165601	165601	165601

*Hydraulic controls include hydraulic flow and pressure control, ball valves, 1 m (3 ft) supply and return hose



19:1 Senator

31:1 Bulldog

Piston Pumps for Ink Applications

Name of Pump	Bulldog 12:1	Viscount II 1200	King 24:1	Viscount II 2400
Lower size	2100	2100	2100	2100
Maximum fluid pressure	82.8 bar (8.28 MPa-1200 psi)	82.8 bar (8.28 MPa-1200 psi)	165 bar (16.5 MPa-2400 psi)	165 bar (16.5 MPa-2400 psi)
Maximum motor inlet pressure	6.9 bar (0.69 MPa-100 psi) (air)	51.7 bar (5.1 Mpa-750 psi) (oil)	6.9 bar (0.69 Mpa-100 psi) (air)	103 bar (10.3 Mpa-1500 psi) (oil)
Flow rate @ 60 cpm	28.4 l/min (7.5 gpm)	28.4 l/min (7.5 gpm)	28.4 l/min (7.5 gpm)	28.4 l/min (7.5 gpm)
Cfm or gpm required per gallon	20 cfm	6 l/min (1.6 gpm)	25 cfm	6 l/min (1.6 gpm)
Fluid pump outlet size	1-1/2" npt (m)	1-1/2" npt (m)	1-1/2" npt (m)	1-1/2" npt (m)
Motor inlet size	3/4" npt (f)	3/4" npt (f)	3/4" npt (f)	3/4" npt (f)
Weight of pump	65 kg (142 lb)	89 kg (196 lb)	73 kg (160 lb)	89 kg (196 lb)
Instruction manual	308149	308149	308149	308149

Bin Supply	Bulldog 12:1	Viscount II 1200	King 24:1	Viscount II 2400
Pump	246935	246937	246936	246937
Air controls: FRL, 1/2"	217072		217072	
Air run away control, 3/4"	224040		224040	
Air speed control, 1/2"(f)	510441		510441	
Floor stand (3" inlet)	222780	222780	222780	222780
Hydraulic controls*		236865		236865
Outlet hydraulic hose connector 1"(m) x 1-1/2"(f), 100 bar (1500 psi) rated		Not included		Not included

Misc. Information	Bulldog 12:1	Viscount II 1200	King 24:1	Viscount II 2400
Pump lower section	246934	246934	246934	246934
Ram plate replacement seals	165601	165601	165601	165601

*Hydraulic controls include hydraulic flow and pressure control, ball valves, 1 m (3 ft) supply and return hose



12:1 Bulldog



Viscount II 2100



24:1 King

Piston Pumps for Ink Applications

Ordering Information and Technical Specifications

Piston Pumps	President 20:1
Lower size	450
Maximum fluid pressure	140 bar (14 MPa-2000 psi)
Maximum motor inlet pressure	7 bar (0.7 MPa-100 psi)
Flow rate @ 60 cpm	4.5 l/min (1.2 gpm)
Cfm or gpm required per gallon	35 cfm
Fluid pump outlet size	3/4" npt (f)
Motor inlet size	1/2" npt (f)
Weight of pump	22.7 kg (50 lb)
Instruction manual	308017

Bin Supply	President 20:1
Pump	246933
Air controls: FRL, 3/8"(f)	110150
Floor stand (3" inlet)	222780
Air run away control, 3/4"(f)	224040
Air speed control 1/2"(f)	510441

Misc. Information	President 20:1
Pump lower section	246932
Ram plate replacement seals	165601



20:1 President

Surge Suppressors

Husky 750 and Husky 2000

Ordering Information

Husky 750, 3/4" npt(f) Surge Suppressors

	Polypropylene wetted bottom housing and non-wetted top housing	Stainless Steel wetted bottom housing and non-wetted top housing	Acetal wetted bottom housing and non-wetted top housing
Automatic			
Weight	4.1 kg (9 lb)	7.3 kg (16 lb)	4.1 kg (9 lb)
Suppressor with Buna-N bladder	239096	239095	239094
Suppressor with PTFE bellows	239121	239123	239125
Suppressor with Fluoroelastomer bladder	239122	239124	not available
Adjustable			
Weight	4.1 kg (9 lb)	7.3 kg (16 lb)	4.1 kg (9 lb)
Suppressor with Buna-N bladder	239091	239090	239089
Suppressor with PTFE bellows	239129	239131	239133
Suppressor with Fluoroelastomer bladder	239130	239132	not available

Husky 2000, 2 in npt(f) Surge Suppressors

	Polypropylene wetted bottom housing and non-wetted top housing	Stainless Steel wetted bottom housing, polypropylene non-wetted top housing
Automatic		
Weight	8.2 kg (18 lb)	16.3 kg (36 lb)
Suppressor with Buna-N bladder	239092	239093
Suppressor with PTFE bellows	239128	239126
Suppressor with Fluoroelastomer bladder	not available	239127
Adjustable		
Weight	8.2 kg (18 lb)	16.3 kg (36 lb)
Suppressor with Buna-N bladder	239087	239088
Suppressor with PTFE bellows	239136	239134
Suppressor with Fluoroelastomer bladder	not available	239135

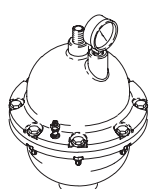

239095
Automatic

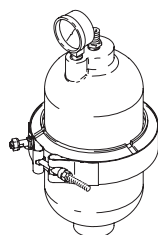

239096
Automatic

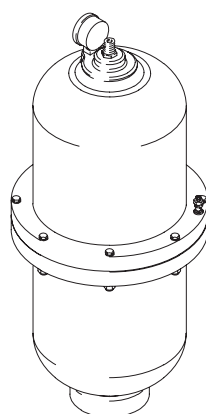

239126
Automatic

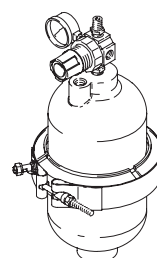

239091
Adjustable

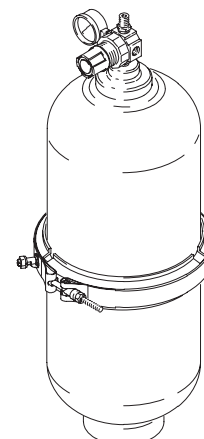

239088
Adjustable

Technical Specifications

Surge Suppressors	Husky 750	Husky 2000
Max. air input pressure	8.4 bar (0.84 MPa, 120 psi)	8.4 bar (0.84 MPa, 120 psi)
Air line connection	1/4 npt	1/4 npt
Fluid inlet size	3/4" npt(f)	2" npt(f)
Instruction manual	308703	308703

Notes



Graco Standard Warranty

Graco warrants all equipment referenced in this document which is manufactured by Graco and bearing its name to be free from defects in material and workmanship on the date of sale by an authorized Graco distributor to the original purchaser for use. With the exception of any special, extended, or limited warranty published by Graco, Graco will, for a period of twelve months from the date of sale, repair or replace any part of the equipment determined by Graco to be defective. This warranty applies only when the equipment is installed, operated and maintained in accordance with Graco's written recommendations.

This warranty does not cover, and Graco shall not be liable for general wear and tear, or any malfunction, damage or wear caused by faulty installation, misapplication, abrasion, corrosion, inadequate or improper maintenance, negligence, accident, tampering, or substitution of non-Graco component parts. Nor shall Graco be liable for malfunction, damage or wear caused by the incompatibility of Graco equipment with structures, accessories, equipment or materials not supplied by Graco, or the improper design, manufacture, installation, operation or maintenance of structures, accessories, equipment or materials not supplied by Graco.

This warranty is conditioned upon the prepaid return of the equipment claimed to be defective to an authorized Graco distributor for verification of the claimed defect. If the claimed defect is verified, Graco will repair or replace free of charge any defective parts. The equipment will be returned to the original purchaser transportation prepaid. If inspection of the equipment does not disclose any defect in material or workmanship, repairs will be made at a reasonable charge, which charges may include the costs of parts, labor, and transportation.

THIS WARRANTY IS EXCLUSIVE, AND IS IN LIEU OF ANY OTHER WARRANTIES, EXPRESS OR IMPLIED, INCLUDING BUT NOT LIMITED TO WARRANTY OF MERCHANTABILITY OR WARRANTY OF FITNESS FOR A PARTICULAR PURPOSE.

Graco's sole obligation and buyer's sole remedy for any breach of warranty shall be as set forth above. The buyer agrees that no other remedy (including, but not limited to, incidental or consequential damages for lost profits, lost sales, injury to person or property, or any other incidental or consequential loss) shall be available. Any action for breach of warranty must be brought within two (2) years of the date of sale.

GRACO MAKES NO WARRANTY, AND DISCLAIMS ALL IMPLIED WARRANTIES OF MERCHANTABILITY AND FITNESS FOR A PARTICULAR PURPOSE IN CONNECTION WITH ACCESSORIES, EQUIPMENT, MATERIALS OR COMPONENTS SOLD BUT NOT MANUFACTURED BY GRACO. These items sold, but not manufactured by Graco (such as electric motors, switches, hose, etc.), are subject to the warranty, if any, of their manufacturer. Graco will provide purchaser with reasonable assistance in making any claim for breach of these warranties.

In no event will Graco be liable for indirect, incidental, special or consequential damages resulting from Graco supplying equipment hereunder, or the furnishing, performance, or use of any products or other goods sold hereto, whether due to a breach of contract, breach of warranty, the negligence of Graco, or otherwise.

Equipment Misuse Hazard

General Misuse: Any misuse of Graco equipment or accessories, such as over-pressurizing, modifying parts, using incompatible chemicals and fluids, or using worn or damaged parts, can cause them to rupture. Misuse of equipment can result in fluid injection, splashing in the eyes or on the skin, or other serious bodily injury, or fire, explosion or property damage. NEVER alter or modify any part of Graco equipment; doing so could cause the product to malfunction. CHECK all equipment regularly and repair or replace worn or damaged parts immediately. Always wear protective eye wear, gloves, clothing and respirator as recommended by fluid and solvent manufacturers.

System Pressure: Be sure that all equipment and accessories used are rated to withstand the applicable MAXIMUM WORKING PRESSURE. DO NOT exceed the maximum working pressure of any component or accessory used in a system.

Fluid and Solvent Compatibility: All chemicals used in a Graco sprayer must be compatible with wetted parts. Consult your chemical supplier to ensure compatibility. Do not use 1:1:1-trichloroethane, methylene chloride, other halogenated hydrocarbon solvents or fluids containing such solvents in this equipment, which contains Aluminium and/or zinc parts. Such use could result in a serious chemical reaction, with the possibility of explosion, which could cause death, serious bodily injury and/or substantial property damage.



Founded in 1926, Graco is a world leader in fluid handling systems and components. Graco products move, measure, control, dispense and apply a wide range of fluids and viscous materials used in vehicle lubrication, commercial and industrial settings.

The company's success is based on its unwavering commitment to technical excellence, world-class manufacturing and unparalleled customer service. Working closely with qualified distributors, Graco offers systems, products and technology that set the quality standard in a wide range of fluid handling solutions. Graco provides equipment for spray finishing, protective coating, paint circulation, lubrication, and dispensing sealants and adhesives, along with power application equipment for the contractor industry. Graco's ongoing investment in fluid management and control will continue to provide innovative solutions to a diverse global market.

All written and visual data contained in this document are based on the latest product information available at the time of publication. Graco reserves the right to make changes at any time without notice.

Graco is certified ISO 9001.

motralec

4 rue Lavoisier . ZA Lavoisier . 95223 HERBLAY CEDEX

Tel. : 01.39.97.65.10 / Fax. : 01.39.97.68.48

Demande de prix / e-mail : service-commercial@motralec.com

www.motralec.com