

GD-600 Well Service Pump

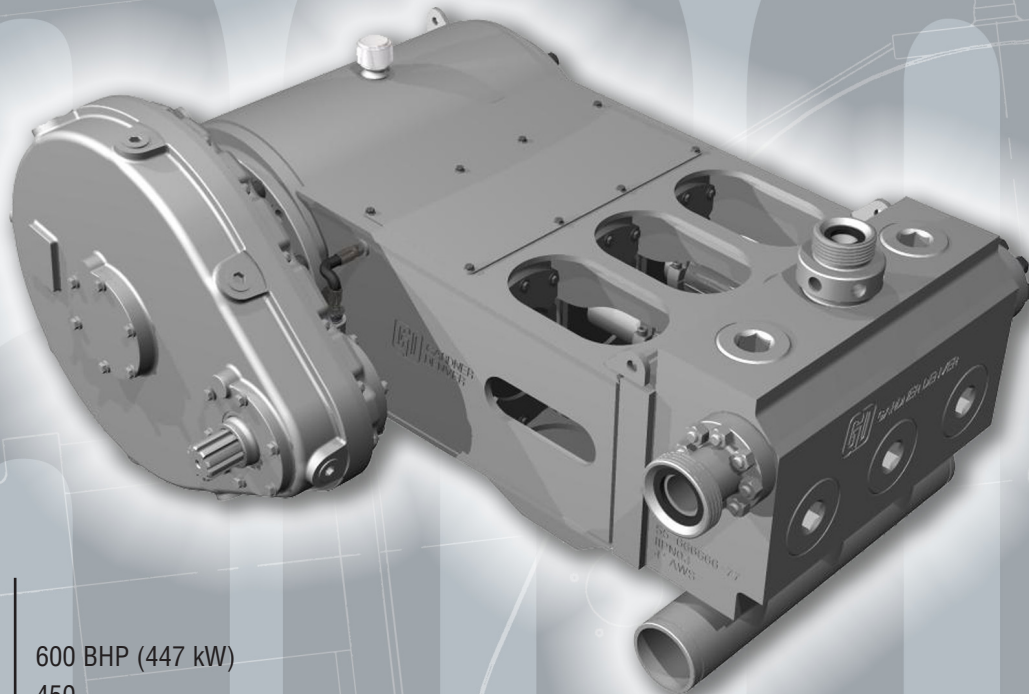

Specifications

Maximum Input	600 BHP (447 kW)
Maximum RPM	450
No. of Plungers	3
Stroke Length	6" (152 mm)
Plunger Load	100,000 lbs. (45,400 kg)
Pump Weight	5,000 lbs. (2,270 kg) average
Gear Ratio	4.68:1

GD-600 Intermittent Duty Well Service Ratings

Plunger Diameter		Displacement per Revolution		Displacement at Pump RPM - Well Service Application															
				100				200				300				450			
in.	mm.	Gal/Rev.	Liter/Rev.	GPM	LPM	PSI	kg/sq. cm	GPM	LPM	PSI	kg/sq. cm	GPM	LPM	PSI	kg/sq. cm	GPM	LPM	PSI	kg/sq. cm
Forged Steel AWS Valve Over Valve Fluid Ends																			
2.75	70	0.463	1.751	46	175	16845	1184	93	350	10004	703	139	525	6669	469	208	788	4446	313
3	76	0.551	2.084	55	208	14154	995	110	417	8406	591	165	625	5604	394	248	938	3736	263
3.5	89	0.749	2.836	75	284	10399	731	150	567	6176	434	225	851	4117	289	337	1276	2745	193
4	102	0.979	3.705	98	370	7962	560	196	741	4729	332	294	1111	3152	222	440	1667	2102	148
4.5	114	1.239	4.689	124	469	6291	442	248	938	3736	263	372	1407	2491	175	557	2110	1660	117
5	127	1.529	5.789	153	579	5096	358	306	1158	3026	213	459	1737	2071	142	688	2605	1345	95
Input Power:		BHP		500				600				600				600			
		kW		373				447				447				447			

Notes: Ratings are based on 90% mechanical efficiency and 100% volumetric efficiency.

Now offer autofretted 2 3/4" and 3" big block fluid ends.

GD-600 Well Service Pump



Standard Features

- Left or right gearbox mounting
- Crankshaft type construction
- Left or right side suction and discharge connections
- Hard coated plungers
- Forged steel fluid end
- Plunger sizes from 2.75 to 5 inches
- Replaceable WECO discharge connections
- Six inch suction manifold with victaulic connections
- Adjustable packing standard, non-adjustable packing optional
- Clamp connections between plungers and pony rods
- Center gauge connection
- Fluid end tool kit

Material Specifications

- | | |
|-------------------------|--------------------------------------|
| • Fluid End | Forged SAE 4330 modified alloy steel |
| • Stuffing Box | Forged steel |
| • Connecting Rods | High-strength nodular iron |
| • Crossheads | High-strength nodular iron |
| • Main Bearing | Roller |
| • Crankpin Bearing | Bronze |
| • Crosshead Pin Bearing | Bronze |

Optional Equipment

- Autofrettaged fluid ends (2.75 and 3")
- Dual discharge flanges
- Additional center gauge connection
- Six inch suction manifold with ANSI flange and/or suction valve lifter cylinder drains
- Tach drive adapter
- Valve seat puller assembly
- Hydraulic torque wrench
- Companion flanges
- Plunger material
- 13" offset gearbox

Fluid End Options

1. Valve over valve 2.75" - 3"
2. Valve over valve 3.5" - 4"
3. Valve over valve 4.5" - 5"
4. Valve over valve 2.75" - 3" Autofrettaged

Fluid End	A	B	C	D
1	35.1	53.4	32.3	67.8
2	35.8	53.4	32.3	67.8
3	36.3	53.4	32.3	67.8
4	37.6	53.4	32.3	68.3

