

GD-250 Well Service Pump

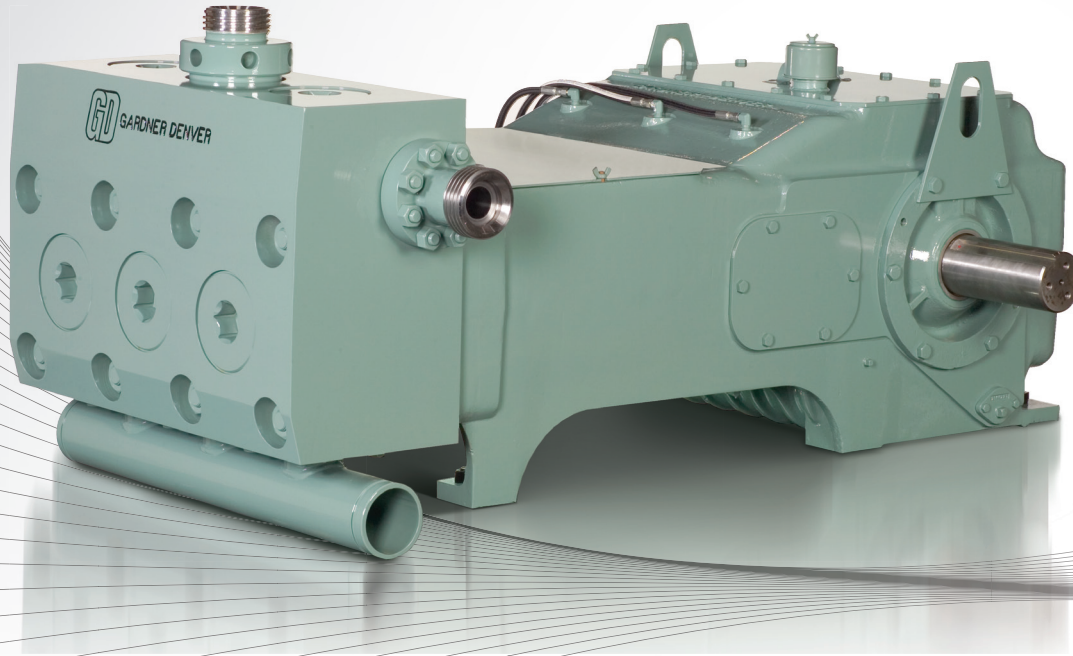

SPECIFICATIONS

Maximum Input	250 BHP (186 kW)
Maximum RPM	300 RPM
Stroke Length	5 in. (127 mm)
Piston Load	50,000 lbs. (222,411 N)
Pump Weight	4,490 lbs (2,037 kg)
Gear Ratio	Optional 4.64:1

PLUNGER/PISTON DIAMETER		DISPLACEMENT PER REVOLUTION		DISPLACEMENT @ PUMP RPM				DISPLACEMENT @ PUMP RPM				DISPLACEMENT @ PUMP RPM				DISPLACEMENT @ PUMP RPM			
				50				100				200				330			
in.	mm.	gal.	liter	GPM	LPM	PSI	bar	GPM	LPM	PSI	bar	GPM	LPM	PSI	bar	GPM	LPM	PSI	bar
2	51	0.20	.77	10	39	15915	1097	20	77	15915	1097	41	154	9452	652	61	232	6301	434
2.5	64	.32	1.21	16	60	10186	702	32	121	10186	702	64	241	6049	417	96	362	4033	278
2.75	70	.39	1.46	19	73	8418	580	39	146	8418	580	77	292	5000	345	116	438	3333	230
3	76	.46	1.74	23	87	7074	488	46	174	7074	488	92	347	4201	290	138	521	2801	193
3.5	89	.62	2.36	31	118	5197	358	62	236	5197	358	125	473	3086	213	187	709	2058	142
4	102	.82	3.09	41	154	3979	274	82	309	3979	274	163	618	2363	163	245	927	1575	109
4.5	114	1.03	3.91	52	195	3144	217	103	391	3144	217	207	782	1867	129	310	1173	1245	86
5	127	1.27	4.83	64	241	2546	176	127	483	2546	176	255	965	1512	104	382	1448	1008	70

Ratings are based on 90% mechanical efficiency and 100% volumetric efficiency.

**Gardner
Denver**
Pumping Perfected.™

GD-250 Well Service Pump

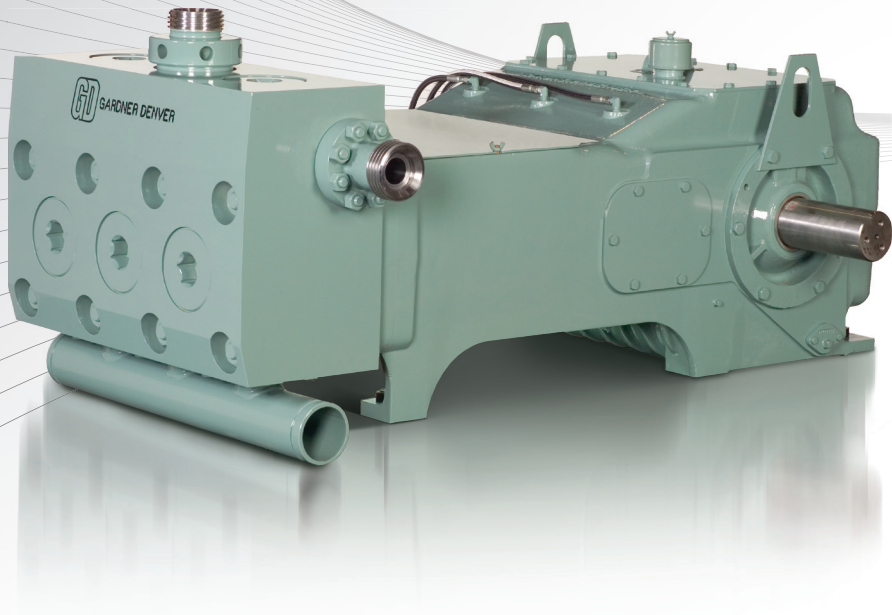

OPTIONAL FEATURES

- DNV, ABS, PED or other third party certifications
- Splined drive shaft
- In line planetary gearbox, 4.64:1 ratio
- Flange for gear reducer
- Dual discharge flanges
- Various plunger packing styles
- Additional center gauge connection
- Custom packaging available

STANDARD FEATURES

- Eccentric construction with left or right side keyed shaft extension
- Bronze connecting rod and crosshead pin bearings
- High-strength cast solid connecting rods
- Pressure lubricated power end (via external oil pump - not supplied)
- Well-stimulation style, high strength, heat-treated alloy steel fluid end with gun-sight suction valve spring retainer
- Through stud fluid end design for maintenance and removal ease
- WECO type discharge flanges
- Wing-guided, urethane insert valves with full open hardened seats
- Left or right side suction and discharge connections
- Plunger and packing construction
- Clamp style connections between plunger and crosshead extension rod
- Four inch suction manifold with victaulic connections

SPECIFICATIONS

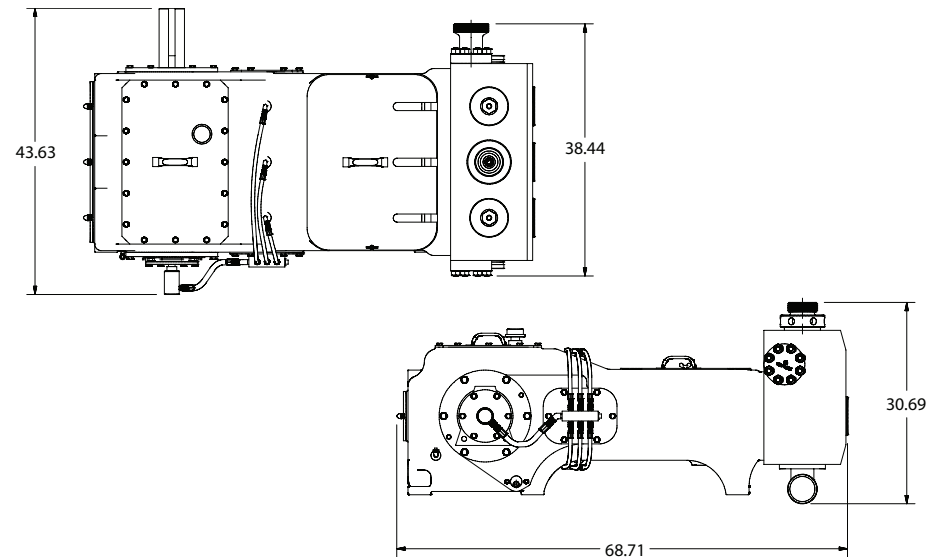

CONNECT WITH US: