



Electronic Capacity Control

maxRoy[®] B, MacRoy[®], mRoy[®], and Milroyal[®]
Product Family Pumps

INSTALLATION, OPERATION, AND MAINTENANCE MANUAL

This manual supersedes the following manuals:
339-0002-000, 339-0006-000, 339-0016-000,
339-0018-000, 339-0051-000, 339-0067-000, and 339-
0083-000 Dated 08/2005 & 09/2009

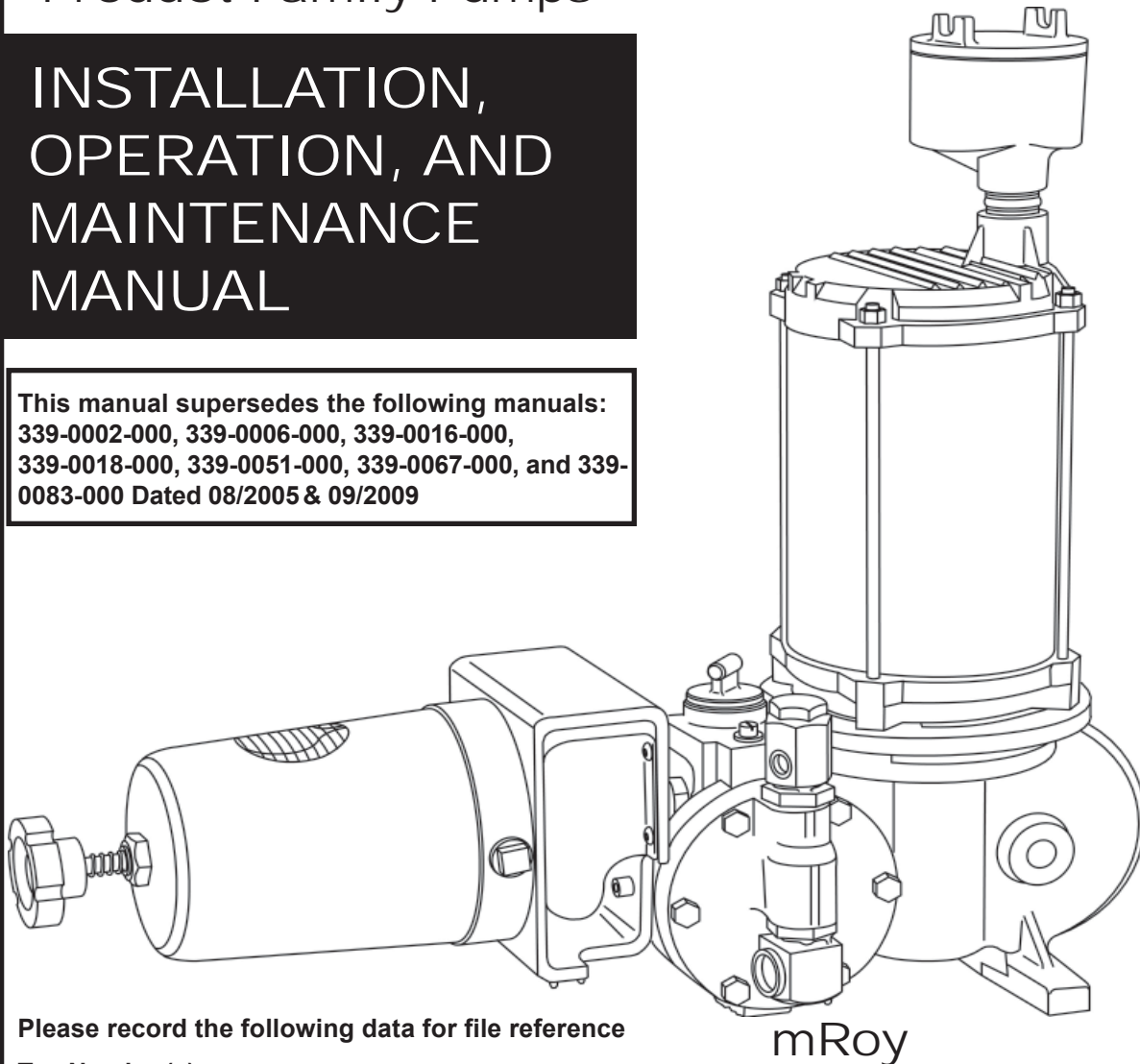

Please record the following data for file reference

Tag Number(s): _____

Model Number: _____

Serial Number: _____

Installation Date: _____

Installation Location: _____

mRoy

339-0083-000

ISSUED 01/2012

PRECAUTIONS

The following precautions should be taken when working with metering pumps.
Please read this section carefully prior to installation.

Protective Clothing

- ! **ALWAYS** wear protective clothing, face shield, safety glasses and gloves when working on or near your metering pump. Additional precautions should be taken depending on the solution being pumped. Refer to **Material Safety Data Sheets** for the solution being pumped.

Hearing Protection

- ! It is recommended that hearing protection be used if the pump is in an environment where the time-weighted average sound level (TWA) of 85 decibels is exceeded. (as measured on the A scale -- slow response)

Electrical Safety

- Remove power and ensure that it remains off while maintaining pump.
- **DO NOT FORGET TO CONNECT THE PUMP TO EARTH**
- ! • Electric protection of the motor (Thermal protection or by means of fuses) is to correspond to the rated current indicated on the motor data plate.

Liquid Compatibility

- ! Verify if the materials of construction of the wetted components of your pump are recommended for the solution (chemical) to be pumped.

Pumps Water “Primed”

- ! All pumps are tested with water at the factory. If your process solution is not compatible with water, flush the **Pump Head Assembly** with an appropriate solution before introducing the process solution

Plumbing and Electrical Connections

- ! Always adhere to your local plumbing and electrical codes.

Line Depressurization

- ! To reduce the risk of chemical contact during disassembly or maintenance, the suction and discharge lines should be depressurized before servicing.

Over Pressure Protection

- ! To ensure safe operation of the system it is recommended that some type of safety/pressure-relief valve be installed to protect the piping and other system components from damage due to over-pressure.

Lifting

- ! This manual should be used as a guide only - Follow your company's recommended lifting procedures. It is not intended to replace or take precedence over recommendations, policies and procedures judged as safe due to the local environment than what is contained herein.

- ! Use lifting equipment that is rated for the weight of the equipment to be lifted.

IMPORTANT SAFETY INSTRUCTIONS

WARNING

WHEN INSTALLING, CALIBRATING, OR OPERATING THIS ACTUATOR, BASIC SAFETY PRECAUTIONS SHOULD ALWAYS BE FOLLOWED TO REDUCE RISK OF FIRE, ELECTRIC SHOCK, AND PERSONAL INJURY. FAILURE TO FOLLOW THESE INSTRUCTIONS COULD RESULT IN DEATH OR SERIOUS INJURY.

Read all instructions before installation, calibration, or operation

GENERAL SAFETY CONSIDERATIONS

- Read this manual carefully.
- Installation, calibration, and maintenance should be performed by trained and qualified personnel. Personnel should be familiar with the precautions required in working with hazardous voltages which exist inside the actuator. Personnel should also be adequately trained on any hazards inherent in the chemicals used in the metering pump.
- Always wear protective clothing including gloves and safety glasses when working on or near chemical metering pumps.
- Follow directions and warnings provided with the chemicals from the chemical manufacturer. User is responsible for determining the hazards associated with the chemicals being pumped and using the proper safety gear and procedures.
- Hazardous voltages are present when cover is removed. Disconnect power when installing or servicing this unit.
- Unit must be properly grounded.
- Conform to local codes in wiring this equipment.
- Actuator must be adequately rated if it is to be used in a hazardous location. See product data plate for rating information. This rating must not be exceeded under any circumstances. To prevent ignition of hazardous atmospheres, cover must be tight while circuits are energized.
- In order to comply with the requirements of agency approvals (see data plate), specifications for conduit connections, wire gauge and type, fastener torque ratings, and operating conditions must be adhered to.

QUICK START GUIDE

NOTE: Read and understand safety instructions before proceeding

READ

- Read and comply with all safety instructions presented in this manual. In order to comply with the requirements of agency approvals (see data plate), specifications for conduit connections, wire gauge and type, fastener torque ratings, and operating conditions must be adhered to.

CONNECT

- Connect AC power. Use conduit connections or cable glands.
- Ground unit.
- Connect command signal.
- Connect feedback signal.

VERIFY

- Voltage selector switch is set to the required voltage (115 or 230 VAC).
- DIP switches are set for desired operation.
 - Command input signal is set to desired operation 4-20 mA or (1-5 VDC). Factory set at 4-20 mA.
 - Feedback signal output is set to desired operation 4-20 mA or (1-5 VDC). Factory set at 4-20 mA.
- Loss of command signal action (unit moves to low signal position or (hold last position). Factory setting moves unit to low signal position.
- If reverse action is required (optional, call factory).

WARNING

HAZARDOUS VOLTAGES ARE PRESENT ON THE CIRCUIT BOARD. TO PREVENT IGNITION OF HAZARDOUS ATMOSPHERES, COVER MUST BE TIGHT WHILE CIRCUITS ARE ENERGIZED.

APPLY POWER

- Apply command signal.
- Apply AC power.

OBSERVE

- Actuator should run to command position and stop.
- Full range of command signal should result in desired range of actuator travel (factory setting is for full travel of 0% to 100%).

CALIBRATE

- If actuator was installed on the pump at the factory, it has been factory calibrated.
- If actuator is a retrofit or a non-standard range is desired, follow the calibration instructions in this manual.

FINISH

- Install cover. Observe torque requirements of 15 ft.-lb. (20 N-m) in hazardous locations.

TABLE OF CONTENTS

IMPORTANT SAFETY INSTRUCTIONS	i
QUICK START	ii
SECTION 1 - DESCRIPTION	1
1.1 GENERAL INFORMATION	1
1.2 PRINCIPLE OF OPERATION	1
1.3 SPECIFICATIONS	1
1.4 PRODUCT MODEL CODING	2
1.5 AGENCY APPROVALS (Figures 1, 2 and 3)	3
SECTION 2 - INSTALLATION	5
2.1 GENERAL INFORMATION	5
2.1.1 Field Installation of ECC	5
2.1.2 ECC Circuit Board Replacement	5
2.1.3 Circuit Board Replacement For ECC(s) Built After January 2000 and/or After A Circuit Board Retrofit Kit Is Replaced	5
2.2 UNPACKING	5
2.3 STORAGE/IDLE SERVICE	6
2.4 SAFETY PRECAUTIONS	6
2.5 MOUNTING	6
2.6 ELECTRICAL CONNECTIONS	6
2.6.1 Installation of Input/Output Command Signal Wiring	7
2.6.2 Input Signal	7
2.6.3 Feedback Output Signal	7
2.6.3.1 Feedback Output Signal 4-20 mA	8
2.6.3.2 Feedback Output Signal 1-5 VDC	8
2.6.4 Installation of Primary Power Wiring	8
2.7 CIRCUIT BOARD RETROFIT KIT INSTALLATION (Table 9)	8
2.7.1 Remove Old Circuit Board	8
2.7.2 Required Modifications	9
2.7.2.1 ECC Part Number 0152226XXX, 0152195XXX (Figure 6)	9
2.7.3 Install New Circuit Board	9
SECTION 3 - OPERATION	13

3.1 CONTROLS	13
3.2 INITIAL START-UP	13
3.2.1 Operating Modes	13
3.2.2 Input Signal	14
3.3 CONTROL RANGE ADJUSTMENT	14
SECTION 4 - MAINTENANCE	17
4.1 SPARE PARTS	17
4.2 RETURNING UNITS TO THE FACTORY	17
4.3 MAINTENANCE	17
4.4 PRINTED CIRCUIT BOARD (PCB) REPLACEMENT	17
4.4.1 Removal of PCB (Figure 15)	17
4.4.2 Installation of PCB	18
4.5 FEEDBACK POTENTIOMETER REPLACEMENT	18
4.5.1 Removal of Feedback Potentiometer	18
4.5.2 Installation of Feedback Potentiometer	18
4.6 NYLON WORM GEAR REPLACEMENT	18
4.6.1 Removal of Nylon Worm Gear	18
4.6.2 Installation of Nylon Worm Gear	19
4.7 MOTOR REPLACEMENT	19
4.7.1 Removal of Motor	19
4.7.2 Installation of Motor	20
4.8 ECC CALIBRATION	20
4.8.1 Calibration Routines	20
4.8.1.1 Calibration A	21
4.8.1.2 Calibration B	22
4.8.1.3 Calibration C	23
SECTION 5 - TROUBLESHOOTING	26
SECTION 6 - PARTS LIST	27
6.1 GENERAL	27
6.2 ILLUSTRATED PARTS LIST	27
6.3 ELECTRONIC CAPACITY CONTROL PARTS LIST	31
6.4 PARTS LIST FOR MROY ECC MOUNTING ADAPTER (MROY "A")	35

6.5	PARTS LIST FOR MROY ECC MOUNTING ADAPTER (MROY “B”)	37
6.6	PARTS LIST FOR MACROY ECC MOUNTING ADAPTER (MACROY “G”, “D” AND MILROYAL G)	40
6.7	PARTS LIST FOR MAXROY ECC MOUNTING ADAPTER (MAXROY “B”)	43
6.8	PARTS LIST FOR MILROYAL ECC MOUNTING ADAPTER AND MOUNTING ADAPTER GUARD ASSEMBLY (MILROYAL “B”)	47
6.9	PARTS LIST FOR MILROYAL ECC MOUNTING ADAPTER AND GEAR DRIVE (MILROYAL “C”)	49
6.10	PARTS LIST FOR MILROYAL ECC MOUNTING (MILROYAL D)	51
APPENDIX A	MAXROY B PUMP ECC INSTALLATION (RETROFIT)	53
APPENDIX A	MILROYAL B PUMP FIELD INSTALLATION (RETROFIT)	55
APPENDIX B	MILROYAL C PUMP FIELD INSTALLATION (RETROFIT)	57
FIGURE 1.	Nema 4 Electronic Capacity Control Data Plate	4
FIGURE 2.	Nema 7 Electronic Capacity Control Data Plate	4
FIGURE 3.	Declaration of Conformity	4
FIGURE 4.	Circuit Board Connectors J4 and J5	7
FIGURE 5.	Circuit Board, 30033.	10
FIGURE 6.	Circuit Board, 0152226XXX, 0152195XXX	10
FIGURE 7.	Conversion Detail	11
FIGURE 8.	Jumper Plugs/Action Mode Conversion	13
FIGURE 9.	Effect of Zero & Span Controls	14
FIGURE 10.	Split Range Operation w/Two Pumps (Typical pH Control System)	14
FIGURE 11.	Circuit Board, Top	15
FIGURE 12.	Circuit Board, Bottom	16
FIGURE 13.	Circuit Board removed.	18
FIGURE 14.	Potentiometer Connector P2 Pins 1 and 2	21
FIGURE 15A.	Electronic Capacity Control (1022483000)	28
FIGURE 15B.	Electronic Capacity Control (1022483000)	29
FIGURE 16.	mRoy “A” ECC Mounting Adapter (DWG. 1021971000)	34
FIGURE 17.	mRoy “B” ECC Mounting Adapter (DWG. 10221460003)	36
FIGURE 18 (Sheet 1 of 2).	MacRoy “G” ECC Mounting Adapter (DWG. 1022118000) Design through “September 2004” and Milroyal “G”	38
FIGURE 18 (Sheet 2 of 2).	MacRoy “D” ECC Mounting (DWG. 1022728000)	39
FIGURE 19.	maxRoy B ECC Mounting Adapter (DWG. 1021572000)	42
FIGURE 20 (Sheet 1 of 2).	Milroyal B ECC Mounting Adapter (DWG. 1022095000)	44
FIGURE 20 (Sheet 2 of 2).	Milroyal B ECC Mounting Adapter Guard Assy (DWG. 1022095000)	45
FIGURE 21.	Milroyal C ECC Mounting Adapter (DWG. 10222850002)	48
FIGURE 22.	Milroyal D ECC Mounting Adapter (DWG. 1022906000)	50

SECTION 1 DESCRIPTION

1.1 GENERAL INFORMATION

In this age of sophisticated process control concepts, many people are taking advantage of the latest breakthroughs in technology to upgrade their own equipment and systems. The Milton Roy Electronic Capacity Control (ECC) easily interfaces with computerized process and process instruments, as the ECC will adjust the output of a metering pump from 0% to 100% in response to a 4 to 20 milliamp or 1 to 5 VDC signal from a computer or other source. This outstanding feature can be purchased as an integral part of the pump, or it can be bought separately and field installed. The ECC mounts to the housing of the pump and operates in place of the manual stroke adjustment.

1.2 PRINCIPLE OF OPERATION

The ECC allows remote adjustment of the volume of liquid delivered by the metering pump. This is accomplished by utilizing a 4-20 mA command signal from a Milton Roy Remote Panel Mount (ARPM-100/200) or Remote Wall Mount (ARWM-100/200) remote controller (manual 3390021000), or a customer's control system. In a closed loop control system, the ECC accepts the computer or controller 4-20 mA signal directly and provides immediate and accurate control of the pump flow under varying process conditions.

When the ECC receives the 4-20 mA command signal, the drive motor responds by moving the ECC to the required position. As the ECC moves, it changes the position of the pump's stroke adjust shaft, thus altering the pump's flow rate. Refer to Table 1 which lists reference manuals containing information on the stroke adjust shaft and pump operation.

Table 1. Stroke Adjust Shaft & Pump Operation Reference Manuals

PUMP	MANUAL
mRoy	3390047000
maxRoy B	3390005000
Milroyal C	3390009000
Milroyal B	3390066000
Milroyal D	3390010000

Table 1. Stroke Adjust Shaft & Pump Operation Reference Manuals

PUMP	MANUAL
MacRoy G	3390049000
MacRoy D	3390076000
Milroyal G	3390064000

If the pump flow rate needs to be monitored, the ECC then communicates its position by outputting a nominal 4-20 mA or (1-5 VDC) signal. This signal can be intercepted and translated by an ARPM-100/200 or ARWM-100/200 or other user supplied equipment to display the current ECC position.

1.3 SPECIFICATIONS

INPUT POWER

115 VAC, 50/60 Hz, 1 phase ±10% (standard)

220 VAC, 50/60 Hz, 1 phase ±10% (optional)

1 amp max

CONTROL SIGNAL INPUT

4-20 mA into 250 ohms impedance (standard)

Direct acting: 4-20 mA (see note below)

Split range: 4-12 mA, 12-20 mA

1-5 VDC 440K load, DIP selectable (optional)

NOTE

As supplied, the ECC is direct acting (pump capacity increases with increasing input signal to ECC) although it may be converted to reverse acting by following the procedure outlined in Section 3, "Operation".

POSITION FEEDBACK OUTPUT

4-20 mA, max 500 ohm load (standard)

1-5 VDC, min. 250 ohms impedance, DIP selectable (optional)

MOTOR RPM

72

ACCURACY

±0.5%

MANUAL OPERATION

Fluted handwheel with ECC unpowered

ENCLOSURE

NEMA 4, IP55 (standard)

Hazardous location (optional)

Enclosure is aluminum with Stainless Steel (SS) shaft

TRAVEL TIME (0% TO 100%)

mRoy - 10 seconds

maxRoy B - 3 minutes

Milroyal D - 1 minute

MacRoy D and G - 3 minutes

Milroyal B, C, and G - 3 minutes

DUTY CYCLE

100% Continuous up to 110°F

75% at 120°F

50% at 140°F

ENVIRONMENTAL

-40°F to 120°F (-40°C to 50°C)

Altitude max 6559ft (2000m)

Relative humidity max 80 % up to 87 °F (31°C), decreasing linearly to 50% at 104°F (40°C)

Installation category 2 (EN61010-1)

Pollution degree 2 (EN61010-1)

1.4 PRODUCT MODEL CODING

MaxRoy B, mRoy , MacRoy and Milroyal product family pumps can be ordered with or without an ECC already attached. If the ECC is ordered with the pump, it is indicated in the pump model code by an “E1”, “E2”, “EA” or “EB” in the capacity adjustment slot. The pump model code can be found on the pump data plate, mounted to the pump.

There are four ECC's customarily supplied with a pump; these models are shown in the product model code tables (Table 2 - Table 8). There are several very similar ECC data plates; some of these are shown in Figure 1 and Figure 2. Please note that the Figure 2 data plate documents what safety and/or hazardous location approvals apply to the unit.

Table 2. mRoy Model Codes

MODEL NUMBER	ENCLOSURE	VOLTAGE 50/60 HZ
PPRW212RMH	Nema 4	115 VAC
PPRW512RMH	Nema 4	230 VAC
PPRX212RMH	Explosion Proof (FM Approved)	115 VAC
PPRX512RMH	Explosion Proof (FM Approved)	230 VAC

Table 3. maxRoy B Model Codes

MODEL NUMBER	ENCLOSURE	VOLTAGE 50/60 HZ
PPGW222RMH	Nema 4	115 VAC
PPGW522RMH	Nema 4	230 VAC
PPGX222RMH	Explosion Proof (FM Approved)	115 VAC
PPGX522RMH	Explosion Proof (FM Approved)	230 VAC

Table 4. Milroyal B Model Codes

MODEL NUMBER	ENCLOSURE	VOLTAGE 50/60 HZ
PPGW242LMH	Nema 4	115 VAC
PPGW542LMH	Nema 4	230 VAC
PPGX242LMH	Explosion Proof (FM Approved)	115 VAC
PPGX542LMH	Explosion Proof (FM Approved)	230 VAC

Table 5. Milroyal C Model Codes

MODEL NUMBER	ENCLOSURE	VOLTAGE
PPGW482LMH	Nema 4	115 VAC 50/60 Hz
PPGW682LMH	Nema 4	230 VAC 60 Hz
PPGW782LMH	Nema 4	230 VAC 50 Hz
PPGX482LMH	Explosion Proof (FM Approved)	115 VAC 50/60 Hz
PPGX682LMH	Explosion Proof (FM Approved)	230 VAC 60 Hz
PPGX782LMH	Explosion Proof (FM Approved)	230 VAC 50 Hz

Table 6. Milroyal D Model Codes

MODEL NUMBER	ENCLOSURE	VOLTAGE 50/60 HZ
Low Pressure PPGW292LMH	Nema 4	115 VAC
Low Pressure PPGW592LMH	Nema 4	230 VAC
Low Pressure PPGX292LMH	Explosion Proof (FM Approved)	115 VAC
Low Pressure PPGX592LMH	Explosion Proof (FM Approved)	230 VAC
High Pressure PPGW212LMH	Nema 4	115 VAC
High Pressure PPGW512LMH	Nema 4	230 VAC
High Pressure PPGX212LMH	Explosion Proof (FM Approved)	115 VAC
High Pressure PPGX512LMH	Explosion Proof (FM Approved)	230 VAC

Table 7. Milroyal G Model Codes

MODEL NUMBER	ENCLOSURE	VOLTAGE 50/60 HZ
PPGW242LMH	Nema 4	115 VAC
PPGW542LMH	Nema 4	230 VAC
PPGX242LMH	Explosion Proof (FM Approved)	115 VAC
PPGX542LMH	Explosion Proof (FM Approved)	230 VAC

Table 8. MacRoy D and G Model Codes

MODEL NUMBER	ENCLOSURE	VOLTAGE 50/60 HZ
PPGW242LMH	Nema 4	115 VAC
PPGW542LMH	Nema 4	230 VAC
PPGX242LMH	Explosion Proof (FM Approved)	115 VAC
PPGX542LMH	Explosion Proof (FM Approved)	230 VAC

1.5 AGENCY APPROVALS (Figures 1, 2 and 3)

WARNING

THE DATA PLATE DOCUMENTS ALL SAFETY AND/OR HAZARDOUS LOCATION APPROVALS THAT APPLY. THESE ARE NOT TO BE EXCEEDED.

The data plate documents all safety and/or hazardous location approvals that apply to the unit. See Figures 1 and 2 for data plate configurations.

All of or some of the following approvals may apply:

- MET Labs U.S. Safety and Explosion proof
- MET Labs Canadian Safety and Explosion proof
- CSA CSA 25/30
- CE
- Safety EN61010-1
- Installation category 2
- Pollution degree 2

EMC directives -

- Emissions EN50081-2
- Immunity EN50082-2
- CENELEC (Flameproof) EN 50014 & 50018
- FM Factory Mutual explosion proof

A declaration of conformity (Figure 3) lists the standards declared by the Milton Roy Company.



 MILTON ROY IVYLAND, PA 18974 (215)441-0800		POWER IN _____
		POWER OUT _____
		MOD.# _____
		SER.# _____
WWW.MILTONROY.COM		

Figure 1. Nema 4 Electronic Capacity Control Data Plate.





 MILTON ROY	  II 3 GD	Milton Roy Co. Ivyland PA U.S.A. WWW.MILTONROY.COM	
		POWER IN _____	
		MOD.# _____	
		SER.#/DATE _____	
CLASS I, II DIV 1, GRPS B,C,D,E,F,G (NEMA TYPE 4) EEx d IIB + H2T5, IP 55, -20° C ≤ Ta ≤ 60° C		 E212134 Hazardous Location	
WARNING TO PREVENT IGNITION OF HAZARDOUS ATMOSPHERES, COVER MUST BE TIGHT WHEN CIRCUIT IS ENERGIZED. SEAL ALL CONDUITS WITHIN 18 IN..			

Figure 2. Nema 7 Electronic Capacity Control Data Plate.

DECLARATION OF CONFORMITY

Application of Council Directive(s): LVD 73/23/EEC as amended by 93/68/EEC;
EMC 89/336/EEC as amended by 91/263/EEC and 92/31/EEC, and CENELEC ATEX 94/9/EG.

Standards to which Conformity is Declared:

<u>LVD:</u>	<u>EN61010</u>
<u>EMC:</u>	<u>EN50081 and EN50082</u>
<u>CENELEC:</u>	<u>EN50014 and EN50018</u>

Declarer's Name/Address: Milton Roy Company - Flow Control Division
201 Ivyland Road
Ivyland, PA 18974 USA

Type of Equipment: Industrial Actuators

Model Number: All "P" series hazardous location.

I the undersigned, hereby declare that the equipment specified above conforms to the above Directive(s) and Standard(s).

	5/8/02
_____	_____
(signature)	(date)
Don Weidemann	Quality Manager
_____	_____
(printed name)	(title)

Figure 3. Declaration of Conformity

SECTION 2 INSTALLATION

2.1 GENERAL INFORMATION

The ECC is usually shipped already mounted to the pump. Installation, therefore, is usually only a matter of connecting the signal wiring (paragraph 2.6.1) and primary power wires (paragraph 2.6.4).

2.1.1 Field Installation of ECC

Field installation of the ECC to an existing pump is usually not recommended due to the precise alignment required.

MacRoy G and MacRoy D pumps cannot be converted in the field to ECC operation.

MROY A/B pumps manufactured before 1987 cannot be converted in the field to ECC operation. The mRoy A/B pump whose housing must have been machined to mount an ECC. Contact the Milton Roy service department if you wish to convert a manually adjusted mRoy pump manufactured after 1987 to ECC operation.

If the ECC was supplied as a field mounting kit, refer to field installation instructions for the following pumps; maxRoy B (Appendix A), Milroyal B (Appendix B) or Milroyal C (Appendix C). Upon completion of the retrofit, proceed with service connections (paragraph 2.4).

2.1.2 ECC Circuit Board Replacement

As ECC circuit boards fail (ECC(s) built before January 2000) at field installations, they are replaced with an ECC circuit board retrofit kit (see Table 9). The circuit board retrofit kit replaces the old circuit board with a new unit. Match your Milton Roy pump to the correct circuit board retrofit kit part number using Table 9. Refer to **CIRCUIT BOARD RETROFIT KIT INSTALLATION** (paragraph 2.7)

2.1.3 Circuit Board Replacement For ECC(s) Built After January 2000 and/or After A Circuit Board Retrofit Kit Is Replaced.

After a conversion kit is installed in the field and/or a new ECC circuit board (ECC(s) built after January 2000) fails order replacement board p/n 30300 for all pumps except Milroyal C. Order p/n 39320 for Milroyal C pumps. **When ordering the replace-**

ment board (p/n 30300/39320) specify what pump the unit is being installed on to insure the replacement board is configured for your pump. This will eliminate problems during installation. Refer to *Printed Circuit Board Replacement* (paragraph 4.4, Section 4)

Table 9. ECC Circuit Board Retrofit Kits

PART NUMBER	FOR ECC(S) BUILT BEFORE JANUARY 2000
21226	mRoy A & B with 115 VAC 50/60 Hz input power
21227	mRoy A & B with 230 VAC 50/60 Hz input power
21228	Milroyal B, Milroyal G or MacRoy G with 115 VAC 50/60 Hz input power
21229	Milroyal B, Milroyal G or MacRoy G 230 VAC 50/60 Hz input power
21230	Milroyal C with 115 VAC 50/60 Hz input power
21231	Milroyal C with 60 Hz 230 VAC input power
21232	Milroyal C with 50 Hz 230 VAC input power
21233	Milroyal D or MacRoy D with 115 VAC 50/60 Hz input power
21234	Milroyal D or MacRoy D with 230 VAC 50/60 Hz input power
21235	maxRoy B with 115 VAC 50/60 Hz input power
21236	maxRoy B with 230 VAC 50/60 Hz input power

2.2 UNPACKING

Units are shipped f.o.b. factory and the title passes to the customer when the carrier signs for receipt of the unit. In the event that damages occur during shipment, it is the responsibility of the customer to notify the carrier immediately and to file a damage claim.

Carefully examine the shipping crate/box upon receipt from carrier to be sure there is no obvious damage to contents. Open the crate/box carefully so accessory items fastened to the inside of the

crate/box will not be damaged or lost. Examine all material inside crate/box and check against packing list to be sure that all items are accounted for and intact.

2.3 STORAGE/IDLE SERVICE

Several ECC components are steel and are subject to corrosive attack during storage/idle time in hot, humid environments. The ECC covers are not air tight. In humid environments, the humidity in the air can condense during cooler evenings, even to the extent that water can accumulate inside the housing. Milton Roy does not warrant against damage caused by corrosion or atmospheric conditions.

With reasonable care at the site, the products and packaging methods will effectively protect new, uninstalled units from corrosion due to water and water vapor for up to one year.

CAUTION

FAILURE TO PROPERLY STORE AND PROTECT THE EQUIPMENT MAY VOID ANY WARRANTY, EXPRESSED OR IMPLIED. OUTDOOR STORAGE IS NOT RECOMMENDED UNDER ANY CIRCUMSTANCES UNLESS SPECIFICALLY PREPARED FOR STORAGE PRIOR TO SHIPMENT FROM THE FACTORY.

The amount of time the ECC can remain in storage or idle service can be extended. Depleted, factory installed desiccant can be removed and replaced with new desiccant. Call the factory at (215) 441-0800 for instructions to properly extend ECC storage.

Maximum Estimated Storage

Indoors, dry ambient controlled temperature:
Initial ----- 12 months
Extend preservation -- 12 additional months

Indoors, dry ambient uncontrolled temperature:
Initial ----- 6 months
Extend preservation----- 6 additional months

Outdoor storage:
Not recommended.

2.4 SAFETY PRECAUTIONS

When installing, operating, and maintaining the ECC, keep safety considerations foremost. Use proper tools, protective clothing, and eye protection when working on the equipment and install the equipment with a view toward ensuring safe operation. Follow the instructions in this manual and take additional safety measures appropriate to the liquid being pumped. **Be extremely careful in the presence of hazardous substances (e.g., corrosives, toxics, solvents, acids, caustics, flammables, etc.)**

2.5 MOUNTING

The Milton Roy ECC is commonly shipped already mounted on a pump. Because of this, installation usually requires connecting the power and signal wires. If the ECC was shipped without a pump, mounting to your pump and minor calibration adjustment is required (Full calibration is performed at the factory and only limited calibration is required after mounting). ECCs installed on pumps outdoors should be protected by a shelter. Care should be taken to keep condensation and moisture from entering via the electrical conduit.

2.6 ELECTRICAL CONNECTIONS

The electrical connections for the ECC are input signal, feedback output signal, and input power. Terminal blocks, with removable connectors are located on the bottom of the circuit board under the ECC cover. Conduit access to the ECC is via two threaded 1/2-14 inch NPT threaded openings in the ECC base. All wiring should conform to National Electrical code s or local codes as they apply. Conduit bushings must be chosen to provide NEMA 4, and explosion proof integrity. In North America, use NEMA type 4 and/or explosion proof conduit fittings. In Europe, cable glands with IP66 and/or EExd ratings are readily available with 1/2-14 inch NPT threads.

WARNING

ALWAYS DISCONNECT PRIMARY POWER BEFORE REMOVING THE COVER FROM THE ECC. FAILURE TO FOLLOW THESE INSTRUCTIONS COULD RESULT IN DEATH OR SERIOUS INJURY

CAUTION

TO AVOID DAMAGE TO SENSITIVE ELECTRONICS, REMOVE THE COVER FROM THE ECC CAREFULLY.

2.6.1 Installation of Input/Output Command Signal Wiring

1. Unscrew the ECC cover by turning it counter-clockwise (as viewed from the top). Lift the cover straight off and away.

CAUTION

IMPROPER CONNECTION OF THE COMMAND LINES CAN CAUSE DAMAGE TO THE ECC. USE ONLY 300 VOLT, 105°C RATED WIRE, MINIMUM 22 AWG, MAXIMUM 14 AWG.

2. Maintain integrity of safety approvals using only 300 volt, 105° C (UL 1213 or equiv.) rated insulation. Maintain CE immunity ratings, using shielded cable inside of conduit.
3. Feed four (14 to 22 AWG) shielded wires through appropriately rated conduit bushing inserted into one of the conduit holes in base of ECC. Ground shields for four wires to a good chassis ground at control end.
4. Route wires to ECC keeping electrical interference to a minimum. Carefully pull four-position connector J5 from circuit board. Connect command signal wires to connector J5 (Figure 4 and 12). Reconnect connector J5 to circuit board.

2.6.2 Input Signal

The input signal, used to control the ECC, can be either 4-20 mA or (1-5 VDC). A five-position Dip switch, SW2 (Figure 11, located on the top of the circuit board) selects the control signal used by the operator. **The factory sets SW2 for the model ordered and should not need changed.** Position 1 (Table 10) of SW2 sets the input signal. Position 2 sets the movement of the ECC after unintentional loss of the control signal. Position 3 and 4 sets the ECC for use with a pump or valve and should always be set to 3-OFF and 4-ON for the pump mode. Position 5 is not used.

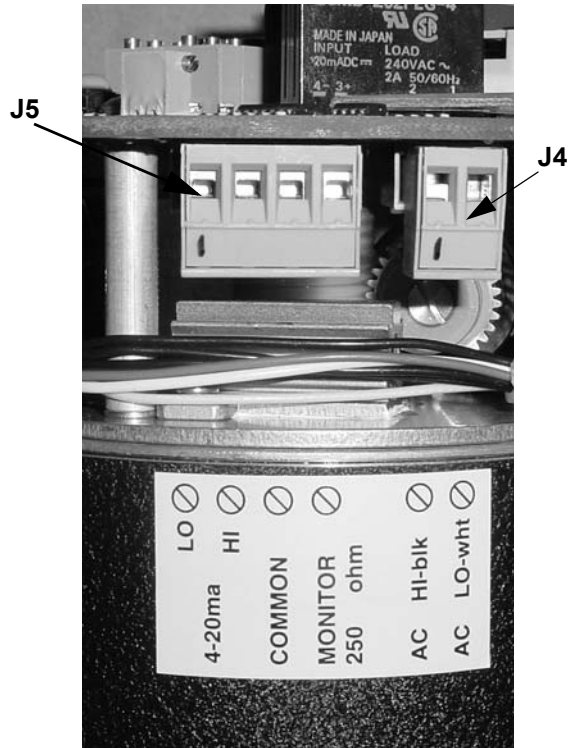

Figure 4. Circuit Board Connectors J4 and J5

Table 10. SW2 DIP Switch Settings

INPUT	SWITCH POSITION				
	1	2	3	4	5
Input Signal of 4-20 mA	ON				
Input Signal of 1-5 VDC	OFF				
Hold Position on Loss of Control Signal		ON			
Return to Lower Limit on Loss of Control Signal		OFF			
Pump Mode (limits absolute)			OFF	ON	
Valve Mode (limits floating)			ON	OFF	
Not Used					NC

2.6.3 Feedback Output Signal

A position output, proportional to ECC position, is used for remote position indication. A current of 4-20 mA or a voltage of 1-5 VDC is available between MONITOR (J5-4) and COMMON (J5-3). Feedback zero and feedback span adjustments (Figure 11) are provided to fine tune the output (see calibration instructions). DIP switch SW3 (Fig-

ure 11) selects the feedback output signal. **Use of the output signal is optional.**

2.6.3.1 Feedback Output Signal 4-20 MA

NOTE

Do not connect the 4-20 mA output to a circuit with greater than a 500 ohm load

Set SW3 per Table 11 for a 4-20 mA feedback signal.

2.6.3.2 Feedback Output Signal 1-5 VDC

NOTE

Do not connect the 1- 5 VDC output to a circuit having less than 250 ohms impedance.

Set SW3 per Table 11 for a 1-5 VDC feedback signal.

Table 11. SW3 DIP Switch Settings

OUTPUT	SWITCH POSITION				
	1	2	3	4	5
Output Signal of 4-20 mA	ON	ON	OFF	OFF	OFF
Output Signal of 1-5 VDC	OFF	OFF	ON	ON	ON

2.6.4 Installation of Primary Power Wiring

Primary power wiring to operate the ECC should be routed via a on /off switch (there are no switches on the ECC) or a panel breaker switch.

1. Maintain integrity of safety approvals using only 300 volt, 105° C (UL 1213 or equiv.) rated insulation.

CAUTION

IMPROPER CONNECTION OF THE POWER LINE OR INCORRECT SUPPLY VOLTAGE CAN CAUSE DAMAGE TO THE ECC. DISCONNECT ALL POWER BEFORE CONNECTING WIRES.

2. Feed three (12 to 16 AWG) primary power wires through a appropriately rated conduit bushing inserted into the other conduit hole in

the base of the ECC. Connect ground wire to screw at ECC end.

3. Carefully pull two-position connector J4 from circuit board (Figure 4). Connect HI-blk and LO-wht wires to terminal block connector J4 (Figure 12). Reconnect connector J4 to circuit board.

CAUTION

VOLTAGE SELECTOR SWITCH SW1 LOCATED ON TOP OF THE CIRCUIT BOARD MUST BE SET TO THE VOLTAGE LISTED ON YOUR DATA PLATE (FIGURE 1 OR 2), OR DAMAGE TO MOTOR WILL RESULT.

Voltage selector switch SW1 (Figure 11), located on top of the circuit board, is a two-position switch used to configure the ECC for an input of 115 VAC or 230 VAC. Insure SW1 is set to the voltage listed on your data plate (Figure 1 or 2), attached to the enclosure. **The factory sets SW1 for the model ordered and should not be changed.** If the operating voltage must be changed, contact the Milton Roy factory at (215) 441-0800 for conversion parts and instructions.

Table 12. SW1 Voltage Selector Switch Setting

For Input Power of 115VAC 50/60Hz Note: The motor and motor run capacitor must be rated for 115VAC operation, or damage will result.	115
For Input Power of 230VAC 50/60Hz Note: The motor and motor run capacitor must be rated for 230VAC operation, or damage will result.	230

2.7 CIRCUIT BOARD RETROFIT KIT INSTALLATION (Table 9)

2.7.1 Remove Old Circuit Board

1. Unscrew ECC cover by turning it counterclockwise (as viewed from the top) . Lift cover straight off and away.
2. If the board you are replacing has terminal blocks for primary and signal wires, loose n screws and remove wires. Label wires before removal to facilitate re-installation.
3. If the old board has plug-in connectors, simply unplug all connectors from circuit board.

- 4. Remove circuit board from its three mounting standoffs.

2.7.2 Required Modifications

Identify old circuit board type (see Figure 5 and 6) and follow directions specific to board. ECC Part Number 30033 - (Figure 5)

No adaptation needed. Motor plug is the same, and the run capacitor will plug directly into the new circuit board. Discard the old cup style safety cover. Proceed to paragraph 2.7.3, "Install New Circuit Board".

2.7.2.1 ECC Part Number 0152226XXX and 0152195XXX (Figure 6)

- 1. Adapter for the motor plug is required, (Milton Roy p/n 04913009000, a 5 pin male to 9 pin female connector).
- 2. Appropriate motor run capacitor is required since these boards had capacitor soldered to circuit board.
- 3. Motor run resistor if used, may need to be relocated on the base plate (Figure 7) to allow room to locate the motor run capacitor.
- 4. The motor run capacitor should be mounted using a new base plate mounting screw, p/n 0405-0264-031 (6-32 x 7/16").

CAUTION

VOLTAGE SELECTOR SWITCH SW1 LOCATED ON TOP OF THE CIRCUIT BOARD MUST BE SET TO THE VOLTAGE LISTED ON YOUR DATA PLATE (FIGURE 1 OR 2), OR DAMAGE TO MOTOR WILL RESULT.

- 5. Voltage selector switch SW1 (Figure 11), located on top of the circuit board, is a two-position switch used to configure the ECC for an input of 115 VAC or 230 VAC. Insure SW1 is set to the voltage listed on your data plate (Figure 1 or 2), attached to the enclosure. The factory sets SW1 for the model ordered and should not be changed. If the operating voltage must be changed, contact the Milton Roy factory at (215) 441-0800 for conversion parts and instructions.
- 6. Set DIP switch SW2 (Paragraph 2.6.2, Input Signal).
- 7. Set DIP switch SW3 for 4-20 mA or (1-5 VDC) output appropriately. (Paragraph 2.6.3, Feedback Output Signal).
- 8. Proceed to paragraph 2.7.3 "Install New Circuit Board".

2.7.3 Install New Circuit Board

- 1. Connect:
 - J1 - - - - - (9-pin motor connector, use adapter as required).
 - J2 - - - - - (3-pin potentiometer connection.)
 - J3 - - - - - (4-pin motor run capacitor connection.)
 - J4 - - - - - (2-pin AC power connector.)
 - J5 - - - - - (4-pin control signal connector.)
- 2. Mount the board on the standoffs utilizing three captive 8-32 screws. Orient circuit board with voltage selector switch over feedback potentiometer (Figure 7).
- 3. Calibrate as required Section 4, Maintenance.



Figure 5. Circuit Board, 30033

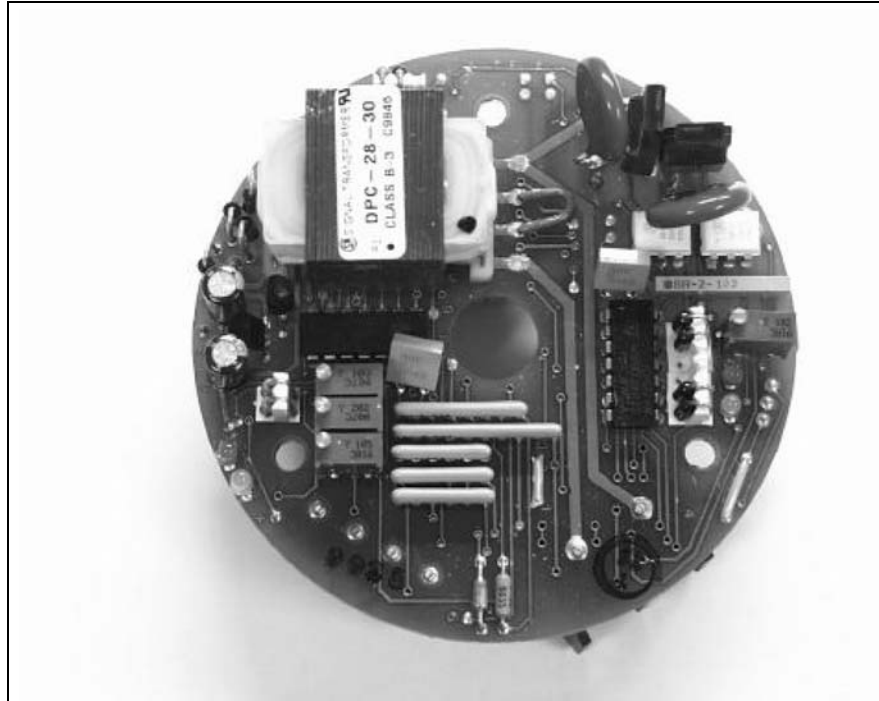

Figure 6. Circuit Board, 0152226XXX, 0152195XXX

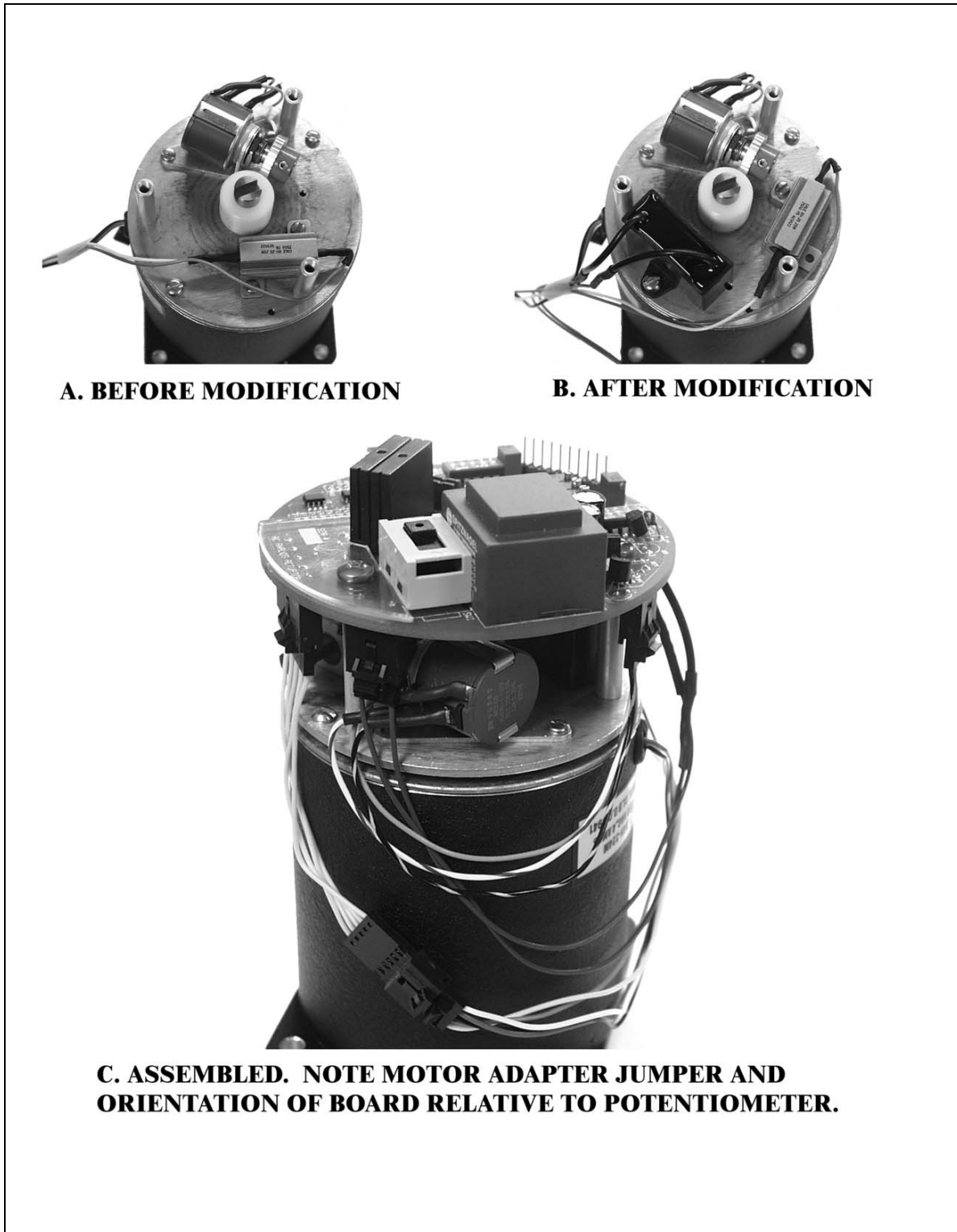

Figure 7. Conversion Detail

THIS PAGE INTRNTIONALLY BLANK

SECTION 3 OPERATION

3.1 CONTROLS

The Milton Roy ECC is equipped with a hand wheel that can be used to reposition the ECC shaft. The hand wheel can only be used when the primary power is off.

3.2 INITIAL START-UP

Fill the pump with oil and prepare the pump for operation according to procedures in the instruction manual for the pump.

1. Check signal connections. The signal HI (+) and signal LO (-) must be connected correctly or the ECC will not respond. (Installation, Section 2)
2. Apply a command signal.

CAUTION

VOLTAGE SELECTOR SWITCH SW1 LOCATED ON TOP OF THE CIRCUIT BOARD MUST BE SET TO THE VOLTAGE LISTED ON YOUR DATA PLATE (FIGURES 1 OR 2), OR DAMAGE TO MOTOR WILL RESULT.

3. Apply AC power.
4. Slowly change the command signal from one extreme to the other. The pump capacity knob should move from 0% to 100% and back to 0%.
5. If the unit performed properly, confirm that all connections have been made properly, install the cover on the ECC. Torque the cover to 15 lb-ft (20 N-m). Install unit in service. (If the pump moved but did not have the proper travel, the ECC may need to be adjusted. See ECC Calibration, Section 4.

3.2.1 Operating Modes

The Milton Roy ECC can be set for one of two modes of operation. The operating mode must be established before the control signal can be set up.

The ECC is factory configured for direct-acting, 4-20 mA command signal range, which is the most common. The model number, found on the data plate, determines the mode set by the factory. The two modes are described below:

1. Direct-acting - an increasing control signal drives the pump to 100% capacity.
2. Reverse-acting - a n increasing control signal drives the pump to 0% capacity.

Perform the following procedure to change the operating mode:

1. Apply power and drive ECC and capacity control knob to 100% capacity setting by applying a 20 mA command signal.
2. Remove power from ECC and remove cover.
3. Install jumper plugs between circuit board and potentiometer and circuit board and motor (Figure 8). Jumper plugs are available from the factory:

- 3 wire jumper 0152173200 (J2)
- 5 wire jumper 40229 (J1)

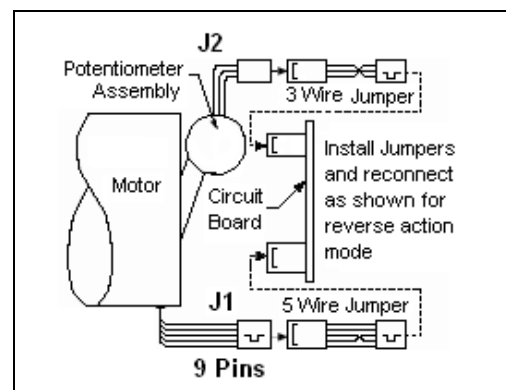

Figure 8. Jumper Plugs/Action Mode Conversion.

4. Disconnect ECC from pump. Remove the four screws that mount the ECC to the bracket and carefully remove the ECC from the pump. On MaxRoy B pumps loosen coupling nut (Figure

19, Item 865) and coupling (860) to allow free rotation of ECC shaft.

5. Apply power to ECC and allow it to run to its new position at a zero mA signal. Ensure the capacity control knob did not rotate.
6. Apply a 4 mA signal to place ECC in reverse-acting mode. This is now the 100% capacity setting.
7. With ECC and pump capacity knob at 100% capacity setting, carefully slide the ECC shaft back into the coupling and replace the four mounting screws. If required, rotate the pump adjustment screw to allow assembly. Do not move the ECC shaft. On MaxRoy B pumps tighten coupling nut (Figure 19, Item 865) and coupling (860) (Approximately 40 lb. ft.). Pin should remain in approximate mid point of slot in coupling.
8. Check operation through full signal range and recalibrate if required (See ECC Calibration, Section 4).

3.2.2 Input Signal

The ECC is shipped from the factory adjusted to accept a 4-20 mA command signal. If the unit is to be operated with any other range, it must be set up for that range.

- Adjusting the span control, VR1, Figure 11, determines the maximum travel of the ECC over the full range of the command signal.
- Adjusting the zero control, VR2, Figure 11 shifts the position of this travel (Figure 9).

The ECC may be set up to operate over a “split range” of either 0 to 100% capacity corresponding to a 12 to 20 mA signal, or 0 to 100% capacity corresponding to a 12 to 4 mA signal (in reverse action mode) - such as pumps A & B in a typical pH control system, shown in Figure 10.

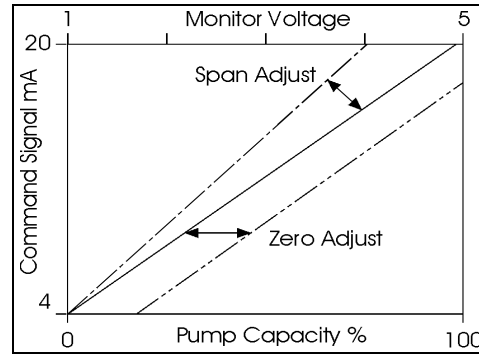

Figure 9. Effect of Zero & Span Controls.

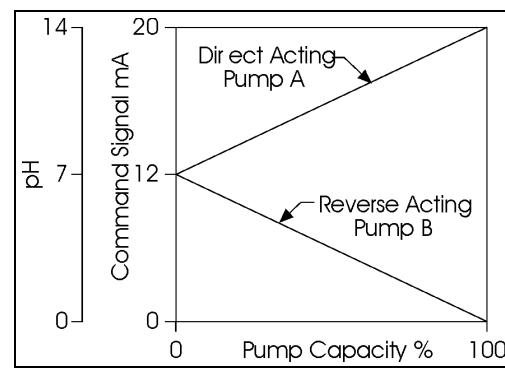

Figure 10. Split Range Operation w/Two Pumps (Typical pH Control System).

3.3 CONTROL RANGE ADJUSTMENT

First remove the cover from the ECC. On the ECC-circuit board, Figure 11, are four lights and four small trim potentiometers. The lights are in pairs. The pots are for zero, span, upper limit, and lower limit adjust.

CAUTION

THE LIMIT POTENTIOMETERS MUST BE SET BEFORE CHANGING THE CONTROL RANGE. THEY MUST BE ADJUSTED (AS THEY ARE AT THE FACTORY) TO PREVENT OVERTRAVEL OF THE CONTROL SPOOL. IMPROPER ADJUSTMENT OF THESE UPPER AND LOWER LIMIT TRIM POTENTIALS MAY RESULT IN DAMAGE TO THE PUMP OR THE ECC.

1. Energize the ECC with AC power.
2. Make sure that the appropriate jumper plugs have already been either removed or installed to establish the desired mode of action (direct action or reverse action) as described earlier in this section.
3. Locate the “Zero” (VR2) and “Span” (VR1) adjust controls on the printed circuit board (PCB) shown in Figure 11.
4. Apply the lower limit input signal to the unit. For a 4-20 mA operating range, this signal will be 4 mA; (for a 12-20 mA range, the lower signal will be 12 mA).
5. Turn the “Zero” (VR2) adjust control until the pump capacity indicator ring moves to the desired point or until no further adjustment is possible, whichever comes first.
6. Apply the upper limit input signal to the unit (this will be 20 mA).
7. Turn the “Span” (VR1) adjust control until the pump capacity control knob moves to the desired point.
8. Repeat Steps 4 through 7 until the desired results are achieved.

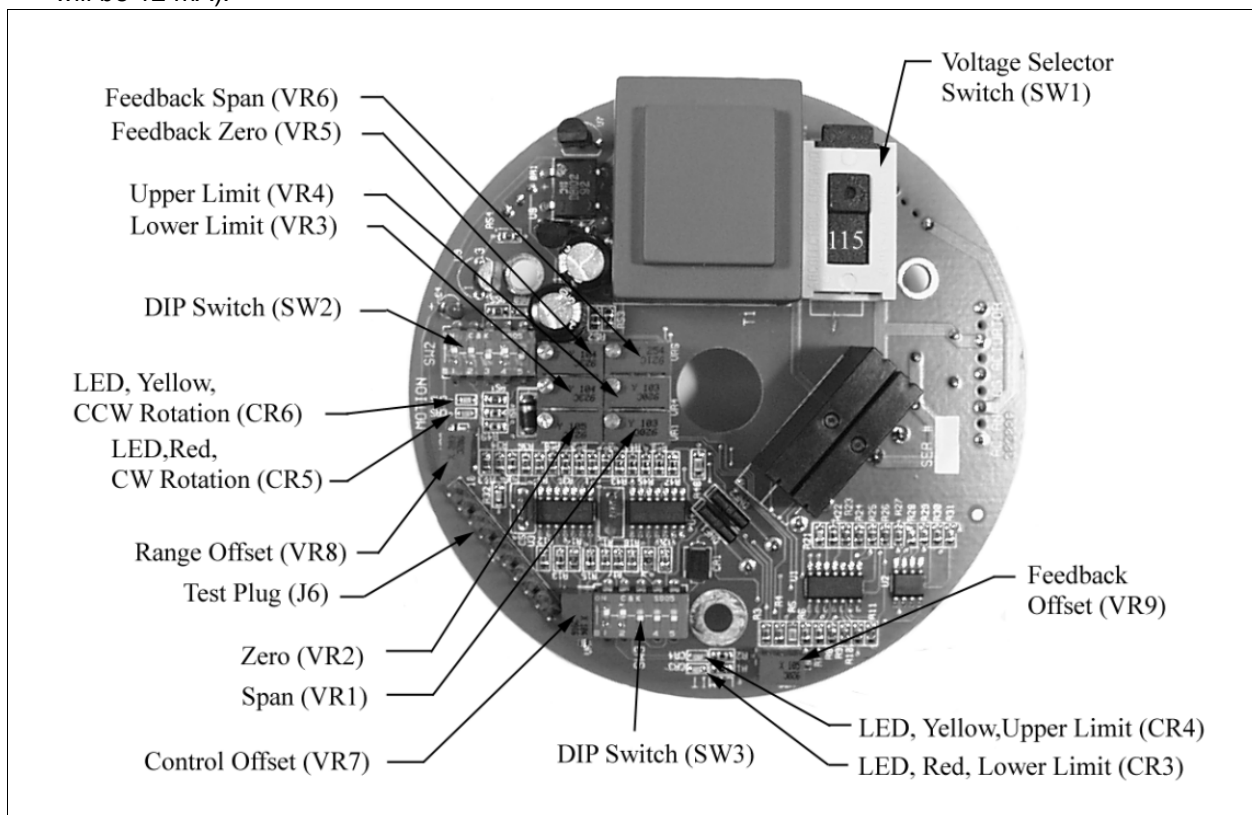

Figure 11. Circuit Board, Top.

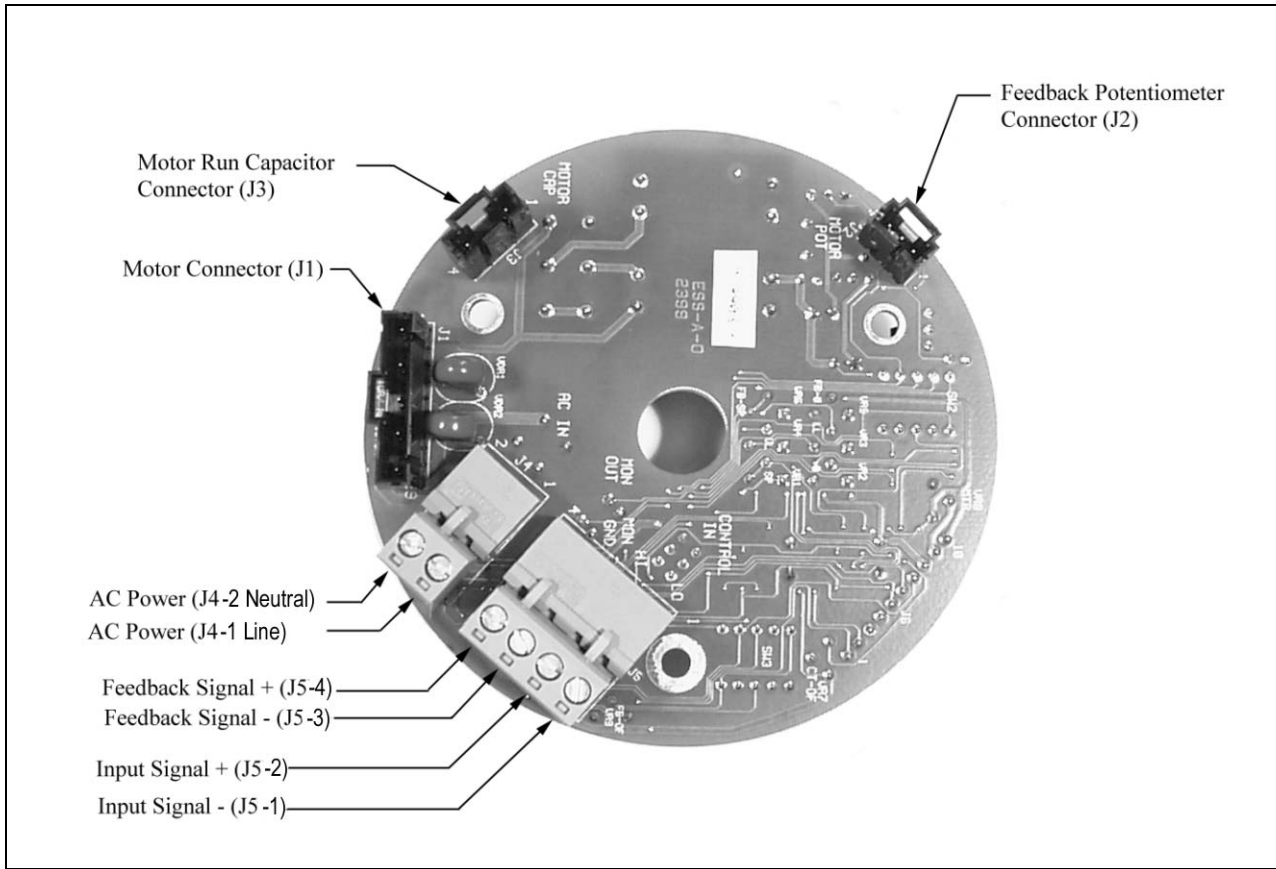

Figure 12. Circuit Board, Bottom.

SECTION 4 MAINTENANCE

4.1 SPARE PARTS

To avoid delays in repairs, the following spare parts should be stocked for your ECC:

NOTE

See Paragraph 2.1.2 and 2.1.3 before ordering circuit boards.

Circuit Board - - - - - 30300/39320

NOTE

When ordering Potentiometer Assy or Motor also order jumper wires. Jumper wires are used when older wiring does not match the color coding of the new parts.

3 wire jumper - - - - - 0152173200
Nylon Worm Gear - - - - - Call Factory
Motor - - - - - Call Factory
5 wire jumper - - - - - 40229

Parts orders must include the following information:

- Pump serial number (on pump nameplate)
- Model number (on ECC nameplate)
- Part description
- Quantity required

Always include the serial and model numbers in all correspondence regarding the unit.

4.2 RETURNING UNITS TO THE FACTORY

Electronic Capacity Control (ECC) units will not be accepted for repair without a Return Material Authorization, available from the Factory Repair Department. If the ECC is being returned attached to a pump, process liquid should be flushed from the pump liquid end and oil should be drained from the pump housing before the pump is shipped. Label the unit clearly to indicate the liquid being pumped.

NOTE

Federal law prohibits handling of equipment that is not accompanied by an OSHA Material Safety Data Sheet (MSDS). A

completed MSDS must be packed in the shipping crate if the ECC is returned attached to a pump. These safety precautions will aid the troubleshooting and repair procedure and preclude serious injury to repair personnel from hazardous residue in pump liquid end.

All inquiries or parts orders should be addressed to your local Milton Roy representative or send to:

Parts Department
Milton Roy Company
Flow Control Division
201 Ivyland Road
Ivyland, PA 18974-0577
Phone: (215)-441-0800
Fax: (215)-441-8620

4.3 MAINTENANCE

Because of its solid-state design, the Milton Roy ECC is exceptionally reliable and should seldom need maintenance or repair. Aside from calibrations (the unit is calibrated at the factory and should not need calibrated initially), the only typical maintenance procedures are replacement of the printed circuit board, feedback potentiometer, nylon worm gear, and/or replacement of the motor.

4.4 PRINTED CIRCUIT BOARD (PCB) REPLACEMENT

4.4.1 Removal of PCB (Figure 15)

1. Apply power and set pump stroke adjust knob to 0% setting or remove power and manually turn the pump stroke adjust knob to 0% setting.

WARNING

ALWAYS DISCONNECT ELECTRICAL POWER FROM THE PUMP MOTOR AND ECC BEFORE PERFORMING ANY MAINTENANCE. FAILURE TO FOLLOW THESE INSTRUCTIONS COULD RESULT IN DEATH OR SERIOUS INJURY.

2. Disconnect electrical power to ECC.

3. Disconnect ECC from its mounting bracket by removing four mounting screws and pulling unit.
4. Unscrew cover (280) from ECC.
5. Carefully loosen three captive screws equally (do not completely remove screws) and gently lift PCB from mounting standoffs.
6. Disconnect connectors J1, J2, J3, J4, and J5 from bottom of PCB.

4.4.2 Installation of PCB

1. Connect connectors J1, J2, J3, J4, and J5 to bottom of PCB.
2. Place PCB on three standoffs and carefully tighten captive screws. Ensure nylon washers are on captive screws between PCB and standoffs.
3. Perform calibration B if board was calibrated at factory or calibration C if board was not calibrated at factory.

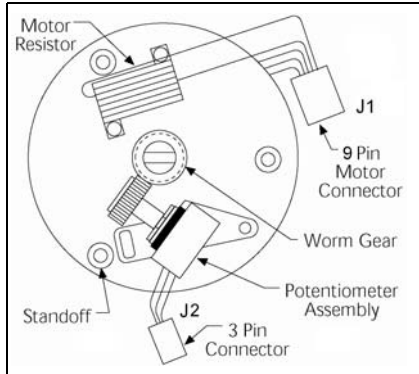

Figure 13. Circuit Board Removed.

4.5 FEEDBACK POTENTIOMETER REPLACEMENT

4.5.1 Removal of Feedback Potentiometer

1. Apply power and set pump stroke adjust knob to 0% setting or remove power and manually turn the pump stroke adjust knob to 0% setting.

WARNING

ALWAYS DISCONNECT ELECTRICAL POWER FROM THE PUMP MOTOR AND ECC BEFORE PERFORMING ANY MAINTENANCE. FAILURE TO FOLLOW THESE INSTRUCTIONS COULD RESULT IN DEATH OR SERIOUS INJURY.

2. Disconnect electrical power to ECC.
3. Remove PCB (Paragraph 4.4.1).
4. Remove two screws that secure potentiometer/bracket/gear assembly. Remove feedback potentiometer.

4.5.2 Installation of Feedback Potentiometer

1. Install replacement potentiometer assembly. Apply very slight pressure and align teeth of gear to lay inside grooves of nylon gear. Do not force gears together overly tight or allow teeth to lay on top of worm gear teeth. Tighten two retaining screws. There should be slight pressure between gears.
2. Apply a very small amount of lithium grease (if needed to motor shaft nylon worm gear. Motor shaft may have grease from previous maintenance.
3. Compare wire colors of new feedback potentiometer connector to wire colors of old feedback potentiometer connector. When placement of wires is different in stall jumper cable (ordered with new feedback potentiometer) between P2 and J2 (Figure 13).

4. Install PCB (Paragraph 4.4.2).

5. Perform calibration A.

4.6 NYLON WORM GEAR REPLACEMENT

4.6.1 Removal of Nylon Worm Gear

1. Apply power and set pump stroke adjust knob to 0% setting or remove power and manually turn the pump stroke adjust knob to 0% setting.

WARNING

ALWAYS DISCONNECT ELECTRICAL POWER FROM THE PUMP MOTOR AND ECC BEFORE PERFORMING ANY MAINTENANCE. FAILURE TO FOLLOW THESE INSTRUCTIONS COULD RESULT IN DEATH OR SERIOUS INJURY.

2. Disconnect power from ECC.
3. Remove PCB (Paragraph 4.4.1).
4. Remove feedback potentiometer (Paragraph 4.5.1).
5. Remove screw that secures capacitor (65) (if installed) to ECC. Slide capacitor to one side away from nylon worm gear (190). Leave wires attached.
6. Using a 3/32 punch, push out spring pin holding nylon gear on shaft. Remove gear.

4.6.2 Installation of Nylon Worm Gear

1. Slide new nylon worm gear (190) over motor shaft and align shaft holes to gear holes with 3/32 punch. Being careful not to damage nylon worm gear, press spring pin (200) through holes in gear and shaft. Place pin equal distance from both sides of gear.
2. Reinstall capacitor (65) (if removed). Tighten screw. Do not allow wires to be pinched under capacitor.
3. Install feedback potentiometer (Paragraph 4.5.2).
4. Install PCB (Paragraph 4.4.2).
5. Perform calibration A.

4.7 MOTOR REPLACEMENT

4.7.1 Removal of Motor

1. Apply power and set pump stroke adjust knob to 0% setting or remove power and manually turn the pump stroke adjust knob to 0% setting.

WARNING

ALWAYS DISCONNECT ELECTRICAL POWER FROM THE PUMP MOTOR AND ECC BEFORE PERFORMING ANY MAINTENANCE. FAILURE TO FOLLOW THESE INSTRUCTIONS COULD RESULT IN DEATH OR SERIOUS INJURY.

2. Disconnect power from ECC.
3. Disconnect ECC from pump. Remove four bolts/screws that mount ECC to bracket and carefully remove ECC from pump.
4. Disconnect gear box (mRoy A and B has no gear box) from ECC. Remove four screws that mount gear box to ECC and carefully remove gear box from ECC.
5. Clean grease from gear located at bottom of motor shaft. Using a 1/8 punch push out spring pin holding gear and slide gear off shaft. Retain gear and spring pin. Parts will be used during installation of new motor.
6. On mRoy A and B ECCs use a 3/16 punch and push out spring pin (Figure 16 and 17, item 920) holding drive shaft (910). Remove drive shaft. Retain drive shaft and spring pin. Parts will be used during installation of new motor.
7. Remove PCB (Paragraph 4.4.1, Steps 4-6).
8. Loosen two screws for feedback potentiometer and slide potentiometer away from worm gear.
9. Note placement of wiring to J1 for identical placement during installation of new motor. Remove two cable ties from connector J1 wiring.
10. Carefully remove two screws (Figure 15, item 140) from adapter plate (60) and remove adapter plate from motor.
11. Remove motor wires from J1.
12. Remove four mounting screws (50) from bottom of base (10) and remove motor.

4.7.2 Installation of Motor

1. Mount motor to base (10) and secure with four mounting screws (50).
2. Connect motor wires to J1.
3. Remove worm gear (190) from old motor. Carefully remove spring pin (200) with 3/32 punch without damage to worm gear (190).
4. Slide worm gear (190) over new motor shaft and align shaft holes to gear holes. Being careful not to damage nylon worm gear, press spring pin (200) through holes in gear and shaft with 3/32 punch. Place pin equal distance from both sides of gear.
5. Attach adapter plate (60) to motor and secure with two screws (140). One screw (140) also mounts capacitor (65) to adapter plate.
6. Apply a very small amount of lithium grease (if needed) to motor shaft nylon worm gear. Motor shaft may have grease from previous maintenance.
7. Reposition feedback potentiometer (Paragraph 4.5.2, Steps 1 & 2).
8. Position wiring to J1 as noted previously and attach two cable ties.
9. Install PCB (Paragraph 4.4.2, Steps 1 and 2).
10. On mRoy A and B ECCs slide drive shaft (Figure 16 and 17, item 910) over bottom of motor shaft and align mounting holes. Press spring pin (920) through both holes with 3/16 punch. Place pin equal distance from both sides of gear.
11. Slide gear removed previously from bottom of motor shaft over new motor shaft. Align shaft holes to gear holes. Being careful not to damage gear, press spring pin through holes in gear and shaft with 1/8 punch. Place pin equal distance from both sides of gear.
12. Apply lithium grease to gear above and mount gear box to ECC with four screws (mRoy A and B has no gear box).

13. Mount ECC to pump. Connect ECC to pump bracket with four bolts/screws.
14. Connect power to ECC.
15. Perform calibration A.

4.8 ECC CALIBRATION

WARNING

YOU WILL BE MAKING ADJUSTMENTS TO THE ECC CONTROL CIRCUIT BOARD WHILE IT IS POWERED UP. THIS CONTROL BOARD IS POWERED BY POTENTIALLY DANGEROUS VOLTAGE (115 OR 230 V AC). THE CALIBRATION PROCEDURE IS TO BE PERFORMED ONLY BY QUALIFIED PERSONNEL FAMILIAR WITH THE HAZARDS INHERENT WORKING NEAR HIGH VOLTAGES. MILTON ROY ASSUMES NO RESPONSIBILITIES FOR DAMAGE TO EQUIPMENT OR INJURY TO PERSONNEL WHILE PERFORMING THIS CALIBRATION PROCEDURE.

NOTE

ECCs are calibrated at the factory and usually do not need to be calibrated initially.

4.8.1 Calibration Routines

The Milton Roy ECC has nine adjustment potentiometers. These potentiometers adjust the ECC's span and zero travel, lower and upper travel limits, feedback zero, feedback span, control of fset, range of fset, and feedback of fset. Control of fset, range of fset, and feedback offset will only be adjusted during a complete calibration procedure (calibration C). These three adjustments are usually not changed.

Before calibration is performed set-up the voltage selector switch, SW1(Paragraph 2.6.4), input signal SW2(Paragraph 2.6.2), and feedback output signal SW3(Paragraph 2.6.3). **Use of the feedback output signal is optional and needs set only if it will be used.**

There are three levels of calibration that can be performed. Use the appropriate calibration routine for your requirement. For all routines, reference Figure 10.

4.8.1.1 Calibration A

Calibration A is performed to synchronize the ECC with the pump. Calibration A is performed when:

- Replacing any components in the position feedback assembly. This includes the nylon worm gear/driver, the potentiometer, and/or the potentiometer gear.
- Adding or removing reverse action jumpers (Section 3).

1. Tools needed for calibration A:

- a) Digital volt meter (DVM) or equivalent with resistance, 5 VDC, and 20 mA.
- b) 4-20 mA (1-5 VDC) source and 115 or 220 VAC source
- c) Precision screwdriver to adjust potentiometers

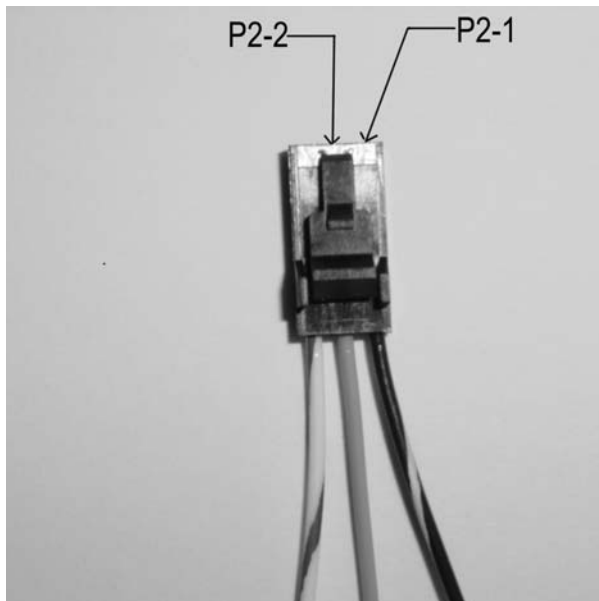

Figure 14. Potentiometer Connector P2 Pins 1 and 2

- d) Tool kit

2. Preparation:

- a) All new components should be replaced.
- b) Ensure pump is set to 0% setting.
- c) Remove AC power.
- d) Remove cover from ECC.

CAUTION

VOLTAGE SELECTOR SWITCH SW1 LOCATED ON TOP OF THE CIRCUIT BOARD MUST BE SET TO THE VOLTAGE LISTED ON YOUR DATA PLATE (FIGURES 1 OR 2), OR DAMAGE TO MOTOR WILL RESULT.

- e) Ensure voltage selector switch is set to 115 VAC or 230VAC as indicated on data plate (Section 2).
 - f) If circuit board has been replaced ensure DIP switches SW2 and SW3 are set as needed for proper operation (Section 2).
 - g) Remove ECC from pump.
3. Remove PCB (Paragraph 4.4.1) to gain access to feedback potentiometer.
 4. Remove P2 and connect DVM between P2 pin 1 and P2 pin 2 (Figure 14). Loosen screws to potentiometer to allow movement of potentiometer gear without moving nylon worm gear. Set potentiometer to 1.5K ohms \pm 100 ohms for Milroyal B, C, and Macroys, 0.87 ohms \pm 0.1 ohms for mRoys and 0.3 ohms \pm 0.1 ohms for Maxroys and Milroyal D E CCs and re-tighten potentiometer screws. This sets the resistance of the potentiometer.
 5. Install PCB (Paragraph 4 .4.2) and perform remaining adjustments.

WARNING

USE EXTREME CAUTION. FULL LINE VOLTAGES ARE PRESENT ON ARE AS OF THE CIRCUIT BOARD.

6. Disconnect J5 (Figure 4 and connect a 4-20 mA current source (or 1-5 VDC) to input signal (high and low) connection at four-position connector located under PCB.

WARNING

USE EXTREME CAUTION. FULL LINE VOLTAGES ARE PRESENT ON ARE AS OF THE CIRCUIT BOARD.

7. Apply AC power to ECC.
8. Apply a 4 mA (1 VDC) control signal and allow motor to run until it stops. Disconnect power.
9. Manually turn **pump** stroke adjust to a position of 0% for direct-acting or 100% for reverse-acting.
10. Install ECC to pump. Do not rotate ECC shaft. If necessary, slightly rotate pump coupling for proper engagement with ECC drive pin. Install and tighten mounting bolts.
11. Using a screwdriver, rotate motor shaft to turn pump stroke adjust to minus 1% (this is 1 percent below 0% reading, shows as "9" on most pump micrometer rings). (Max Roy pump has mechanical stops).
12. **Low signal adjust:** Disconnect motor lead, J1. Apply a 4 mA (1 VDC) signal and adjust **zero pot (VR2)** until both motion lights are off (CR5 and CR6). Adjust **lower limit LED (CR3)** until just on using (VR3), if needed. Adjust **feedback zero pot (VR5)** to 4 mA (1 VDC), if needed.

NOTE

The MaxRoy B, Milroyal B, C, G, MacRoy G, and D uses a 20:1 gearbox. It requires 200 turns at the actuator handwheel to adjust the pump stroke 10 turns (0% to 100%). The Milroyal D uses a 5:1 or 12:1.

13. Manually turn pump stroke adjust to a position of 100% (101%) for direct-acting or 0% (-1%) for reverse-acting. (The Max Roy pump has mechanical stops.)
14. **High signal adjust:** Apply 20 mA (5 VDC) signal and adjust **span pot (VR1)** until both motion lights are off. Adjust upper limit LED (CR4) until just on (VR4), if needed. Adjust **feedback span pot (VR6)** to 20 mA (5 VDC), if needed.
15. **Verify:** Verify travel with low and high signal. Readjust feedback zero and feedback span if needed for travel. Readjust limits until limit LEDs are just on, if needed.
16. Disconnect input and output control signal wiring, reconnect all connectors, and install ECC cover.

4.8.1.2 Calibration B

Calibration B is performed to synchronize the ECC with the pump.

- Calibration B is performed after replacing the circuit board with a new board that has been factory calibrated.

1. Tools needed for calibration B:
 - a) Digital volt meter (DVM) or equivalent with resistance, 5 VDC, and 20 mA.
 - b) 4-20 mA (1-5 VDC) source and 115 or 220 VAC source
 - c) Precision screwdriver to adjust potentiometers
 - d) Tool kit
2. Preparation:
 - a) Ensure new circuit board is replaced.
 - a) Remove AC power.
 - b) Remove cover from ECC.

CAUTION

VOLTAGE SELECTOR SWITCH SW1 LOCATED ON TOP OF THE CIRCUIT BOARD MUST BE SET TO THE VOLTAGE LISTED ON YOUR DATA PLATE (FIGURES 1 OR 2), OR DAMAGE TO MOTOR WILL RESULT.

- c) Ensure voltage selector switch is set to 115 VAC or 230 VAC as indicated on data plate (Section 2).
- d) If new circuit board has been replaced ensure DIP switches SW2 and SW3 are set as needed for proper operation (Section 2).
- e) Remove ECC from pump.

WARNING

USE EXTREME CAUTION. FULL LINE VOLTAGES ARE PRESENT ON ARE AS OF THE CIRCUIT BOARD.

- 3. Disconnect J5 (Figure 4) and connect a 4-20 mA current source (or 1-5 VDC) to input signal (high and low) connection at four-position connector located under PCB.

WARNING

USE EXTREME CAUTION. FULL LINE VOLTAGES ARE PRESENT ON ARE AS OF THE CIRCUIT BOARD.

- 4. Apply AC power to ECC.
- 5. Apply a 4 mA (1 VDC) control signal and allow motor to run until it stops. Disconnect power.
- 6. Manually turn **pump** stroke adjust to a position of 0% for direct-acting or 100% for reverse-acting.
- 7. Install ECC to pump. Do not rotate ECC shaft. If necessary, slightly rotate pump coupling for proper engagement with ECC drive pin. Install and tighten mounting bolts.

- 8. Using a screwdriver, rotate motor shaft to turn pump stroke adjust to minus 1% (this is 1 percent below 0% reading, shows as "9" on most pump micrometer rings). (Max Roy pump has mechanical stops).
- 9. **Low signal adjust:** Disconnect motor lead, J1. Apply a 4 mA (1 VDC) signal and adjust **zero pot (VR2)** until both motion lights are off (CR5 and CR6). Adjust lower limit LED (CR3) until just on (VR3), if needed. Adjust **feedback zero pot (VR5)** to 4 mA (1 VDC), if needed.

NOTE

The MaxRoy B, Milroyal B, C, G, MacRoy G, and D uses a 20:1 gearbox. It requires 200 turns at the actuator handwheel to adjust the pump stroke 10 turns (0% to 100%). The Milroyal D uses a 5:1 or 12:1.

- 10. Manually turn pump stroke adjust to a position of 100% (101%) for direct-acting or 0% (-1%) for reverse-acting. (The Max Roy pump has mechanical stops).
- 11. **High signal adjust:** Apply 20 mA (5 VDC) signal and adjust **span pot (VR1)** until both motion lights are off. Adjust upper limit LED (CR4) until just on (VR4), if needed. Adjust **feedback span pot (VR6)** to 20 mA (5 VDC), if needed.
- 12. Verify: Verify travel with low and high signal. Readjust feedback zero and feedback span if needed for travel. Readjust limits until limit LEDs are just on, if needed.
- 13. Disconnect input and output control signal wiring, reconnect all connectors and install ECC cover.

4.8.1.3 Calibration C

Calibration C is a complete calibration. Performed after replacing a circuit board with a new board that was **not factory calibrated**. For example, A user may want to move an ECC from a mRoy series of pumps to a Milroyal B series. This procedure would be used to now set up the Milroyal B ECC. It is important for the user to understand that circuit boards obtained from the manufacturer are pre set

for a specific series of pumps. This procedure can also be used as a diagnostic tool to verify the integrity of a circuit board. Only qualified personnel familiar with the complete calibration procedure should use it as a diagnostic tool.

1. Tools needed for calibration C:
 - a) Digital volt meter (DVM) or equivalent with resistance, 5 VDC, and 20 mA.
 - b) 4-20 mA (1-5 VDC) source and 115 or 220 VAC source
 - c) Precision screwdriver to adjust potentiometers
 - d) Tool kit
2. Preparation:
 - a) Ensure circuit board has been replaced.
 - b) Remove AC power.
 - c) Remove cover from ECC.

CAUTION

VOLTAGE SELECTOR SWITCH SW1 LOCATED ON TOP OF THE CIRCUIT BOARD MUST BE SET TO THE VOLTAGE LISTED ON YOUR DATA PLATE (FIGURES 1 OR 2), OR DAMAGE TO MOTOR WILL RESULT.

- d) Ensure voltage selector switch is set to 115 VAC or 230VAC as indicated on data plate (Section 2).
- e) Ensure DIP switches SW2 and SW3 are set as needed for proper operation (Section 2).
- f) Remove ECC from pump.

NOTE

Table 13 lists the resistances value of VR8 that is set at the manufacturer on circuit-card 30300/39320 when the series (pump) it is being used on is specified.

Table 13. Circuit Board 30300 Resistance Values

PRODUCT SERIES	RESISTANCE VALUE - OHMS, ADJUST VR8 TO GET
All Value ECCs	1,450 to 1,550
All mRoy Pumps	1,450 to 1,550
Milroyal B, C, & G	9,800 to 10,800
Milroyal D	8,600 to 8,700
MacRoy G	9,800 to 10,800
maxRoy B	9,800 to 10,800

NOTE

Values above must be obtained with feedback potentiometer connector J2 unplugged. Replace J2 after resistance is set.

- g) Disconnect feedback potentiometer connector J2.
 - h) Connect a DVM across test pins J6-9 and J6-10 located on top of PCB (Figure 11). Adjust **range offset (VR8)** for the value of your product, see Table 13 (VR8 may not need adjusted).
 - i) Connect feedback potentiometer connector J2.
3. Initial adjustments for zero (VR2), control offset (VR7), feedback offset (VR9), and feedback zero (VR5) (Figure 11). (ECC may be on or off the pump.)

WARNING

USE EXTREME CAUTION. FULL LINE VOLTAGES ARE PRESENT ON AREAS OF THE CIRCUIT BOARD.

- a) Disconnect motor lead, J1. Apply 4 mA (1 VDC) input signal. Apply 115 or 230 VAC power.
- b) Attach negative lead of DVM to pin 8 of test connector J6.

- c) Measure J6-1. Manually move ECC motor shaft to adjust feedback pot for +1 VDC \pm 0.1 VDC (carefully use large screwdriver through center hole in circuit board to manually turn motor shaft).
 - d) Measure J6-2. Adjust **zero pot (VR2)** for -1 VDC \pm 0.05 VDC.
 - e) Measure J6-4. Adjust **control-offset pot (VR7)** for -1 VDC \pm 0.05 VDC.
 - f) Measure J6-3. Should read 0.00 VDC or close to it.
 - g) Measure J6-6. Adjust **feedback offset (VR9)** for 0.00 VDC \pm 0.1 VDC.
 - h) Measure J6-7 with DVM set to mA range (VDC range for 1-5 VDC output). Adjust **feedback zero (VR5)** for 4 mA \pm 0.1mA (1 VDC \pm 0.1 VDC).
 - i) If any Initial adjustments for zero (VR2), control offset (VR7), feedback offset (VR9), or feedback zero (VR5) can not be attained set VR3 full CCW and VR4 full CW and complete paragraph 4.8.1.3 step 2. a through 3. h.
4. Adjustments for **span (VR1)** and **feedback span (VR6)**.
 - a) Disconnect motor lead, J1. Apply 20 mA (5 VDC) input signal. Reset DVM for VDC range.
 - b) Measure J6-1. Manually move ECC motor shaft to adjust feedback pot for +5 VDC.
 - c) Adjust **span pot (VR1)** until both motion LEDs (CR5 and CR6) are off.
 - d) Measure J6-6. Adjust **feedback span (VR6)** for -4 VDC.
 5. Reconnect P1 and apply power. Vary input signal from low to high and observe correct operation.
 6. Apply a 4 mA (1 VDC) control signal and allow motor to run until it stops. Disconnect power.
 7. Manually turn **pump** stroke adjust to a position of 0% for direct-acting or 100% for reverse-acting.
 8. Install ECC to pump. Do not rotate ECC shaft. If necessary, slightly rotate pump coupling for proper engagement with ECC drive pin. Install and tighten mounting bolts.
 9. Using a screwdriver, rotate motor shaft to turn pump stroke adjust to minus 1% (this is 1 percent below 0% reading, shows as "9" on most pump micrometer rings). (Max Roy pump has mechanical stops).
 10. **Low signal adjust:** Disconnect motor lead, J1. Apply a 4 mA (1 VDC) signal and adjust **zero pot (VR2)** until both motion lights are off (CR5 and CR6). Adjust **lower limit LED (CR3)** until just on (VR3), if needed. Adjust **feedback zero pot (VR5)** to 4 mA (1 VDC), if needed.
- NOTE**
- The MaxRoy B, Milroyal B, C, G, MacRoy G, and D uses a 20:1 gearbox. It requires 200 turns at the actuator handwheel to adjust the pump stroke 10 turns (0% to 100%). The Milroyal D uses a 5:1 or 12:1.
11. Manually turn pump stroke adjust to a position of 100% (101%) for direct-acting or 0% (-1%) for reverse-acting. (Max Roy pump has mechanical stops.)
 12. **High signal adjust:** Apply 20 mA (5 VDC) signal and adjust **span pot (VR1)** until both motion lights are off. Adjust upper limit LED (CR4) until just on (VR4), if needed. Adjust **feedback span pot (VR6)** to 20.00 mA (5 VDC), if needed.
 13. Verify: Verify travel with low and high signal. Readjust feedback zero and feedback span if needed for travel. Readjust limits until limit LEDs are just on, if needed.
 14. Disconnect input and output control signal wiring, reconnect all connectors, and install ECC cover.

SECTION 5 TROUBLESHOOTING

<p>ECC moves to same position regardless of signal applied</p>	<ul style="list-style-type: none"> • Improper command signal applied to ECC. Connect mA meter into signal line. Read signal. If necessary, correct signal source, possible broken wire, loose connection, etc. • Mode setup incorrect. Review initial start-up procedure. • Feedback potentiometer gear slipping or worn. Manually move knob, apply control signal, and observe gear. If necessary, replace feedback potentiometer assembly.
<p>Limit lights flicker as ECC moves</p>	<ul style="list-style-type: none"> • Bad feedback potentiometer. With oscilloscope, observe pot signal while in motion. If necessary, replace feedback potentiometer assembly. • Bad connection at plugs. Check continuity. Repair or replace plugs and/or wiring as necessary. • Bad printed circuit board. Replace PC board.
<p>ECC does not respond to 4-20 mA command signal</p>	<ul style="list-style-type: none"> • No power to ECC. Correct by applying AC power to ECC. • Polarity of 4-20 mA signal wires connected to terminals may be backwards. Check polarity and correct if improper. • Motor frozen in place. With power off, use handwheel to check motor rotation. Replace motor if necessary. • Potentiometer bad. Replace potentiometer. • Bad printed circuit board. Replace PC board.
<p>ECC will only travel in one direction</p>	<ul style="list-style-type: none"> • Bad printed circuit board. Replace PC board.
<p>ECC chatters or vibrates</p>	<ul style="list-style-type: none"> • ECC is driving the pump adjustment against the pump's mechanical stop. Reset the ECC and pump high and low limits per calibration procedure. • If limits are okay, then circuit board and/or feedback potentiometer should be replaced.

SECTION 6 PARTS LIST

6.1 GENERAL

1. This section gives information regarding replaceable components.

6.2 ILLUSTRATED PARTS LIST

1. Figure and Item Number Column

- a) The item numbers shown in the detailed parts list correspond to the item numbers appearing on the exploded view illustration. To find an unknown part number, locate the part on the illustration and note the item number. Look for the item number on the detailed parts list. The part number is on the same line. A dash (-) precedes non-illustrated item numbers.

2. Description Column

- a) The name of the item is in the description column.

3. Part Number Column

- a) The supplier's part number is listed in the part number column.

4. Quantity Column

- a) The numbers appearing in the quantity column are the total quantity of the listed part required in its immediate assembly.

5. Reference Code Column

- a) This column is used to denote assembly and detail part variations among similar components (models) covered by this publication. When the symbol "A", "B", etc. is entered in this column, the part is used only in the model at which the symbol appears. If the column is blank, the part is used in all models.

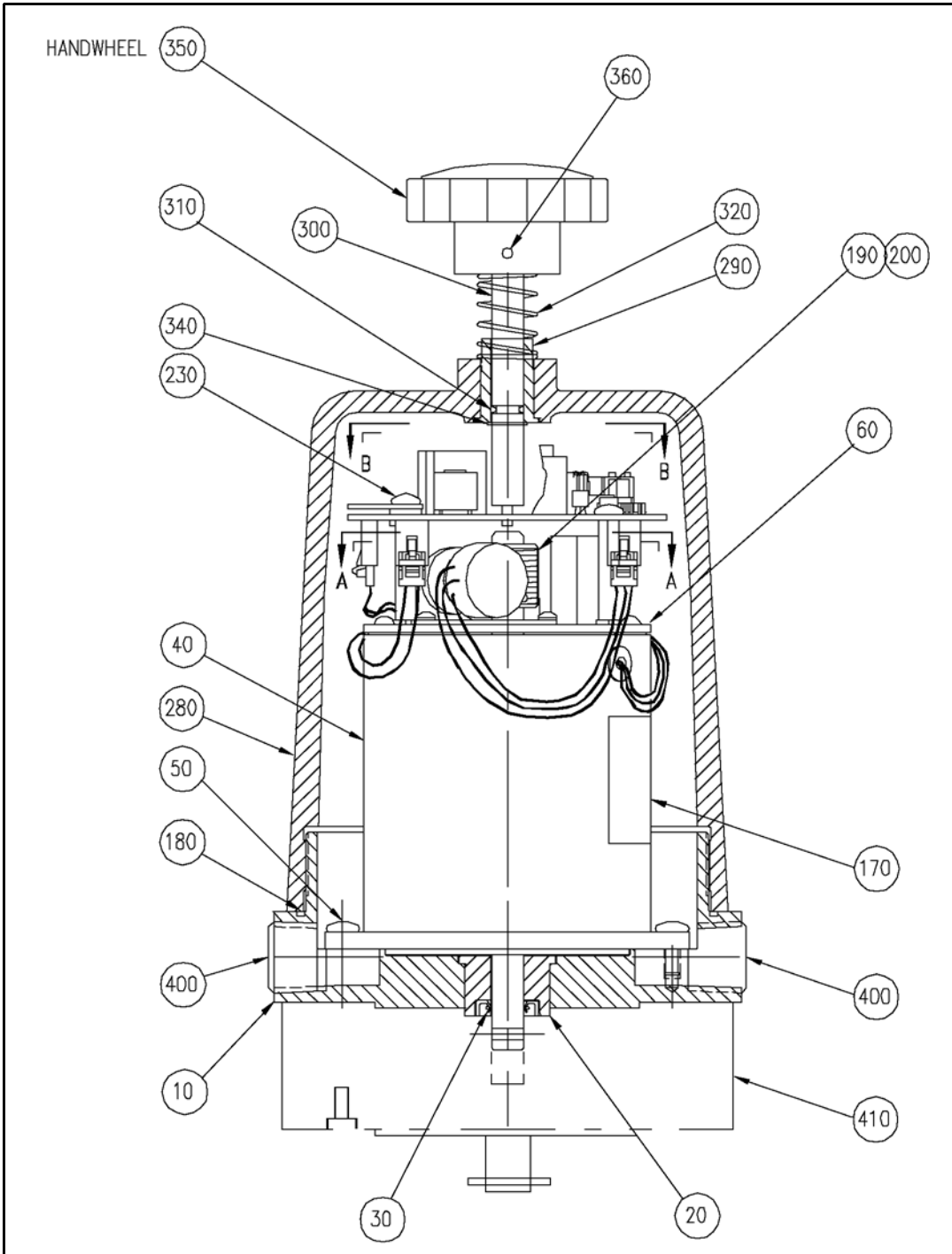

Figure 15A. Electronic Capacity Control (1022483000).

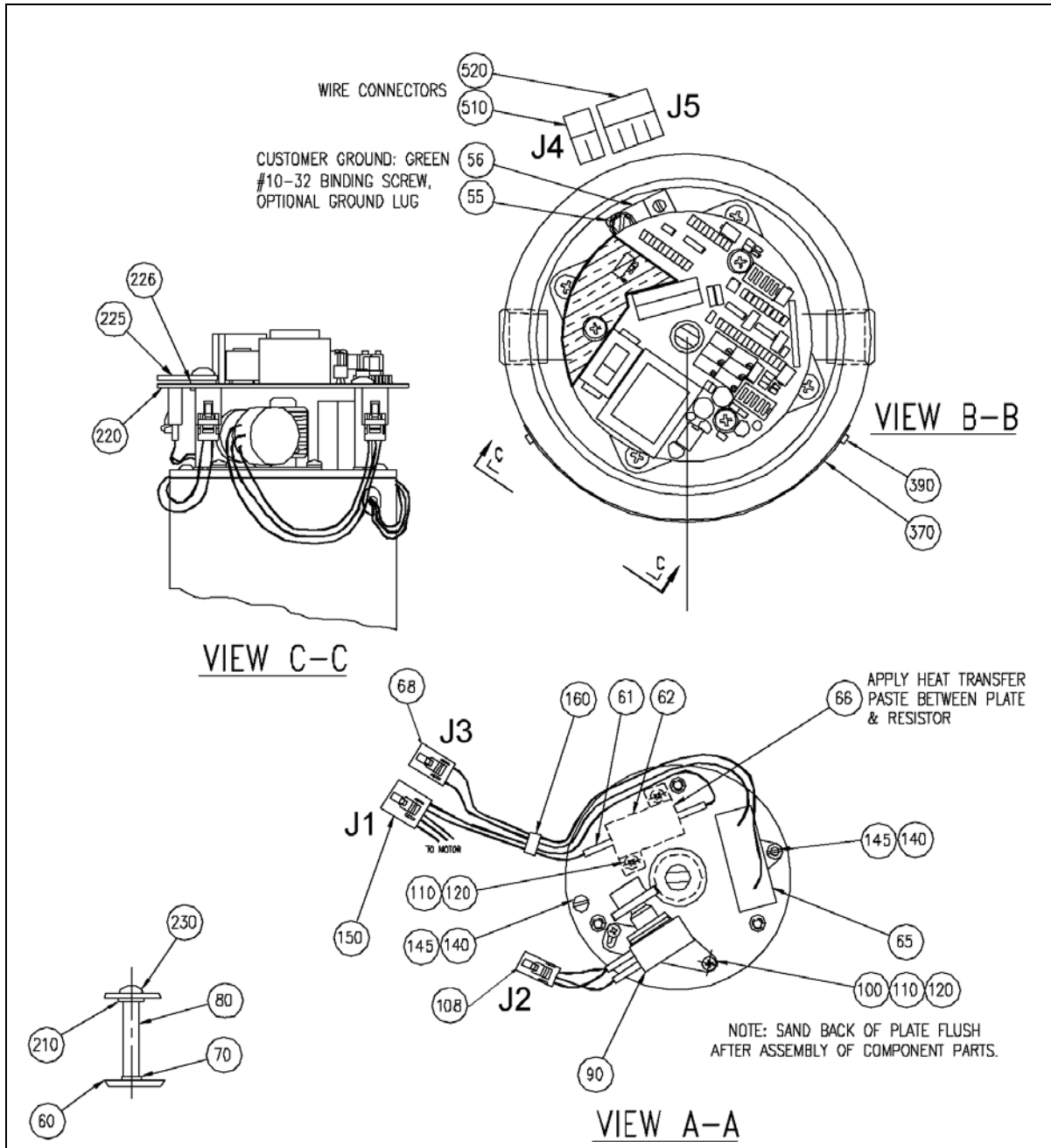

Figure 15B. Electronic Capacity Control (1022483000).

THIS PAGE INTENTIONALLY BLANK

6.3 ELECTRONIC CAPACITY CONTROL PARTS LIST

<u>Model:</u>	<u>Code:</u>	<u>Model:</u>	<u>Code:</u>
MacRoy G & D	A	Milroyal B	D
mRoy	B	Milroyal C	E
maxRoy B	C	Milroyal D	F
		Milroyal G	G

FIGURE NUMBER	ITEM NUMBER	DESCRIPTION	PART NUMBER	QUANTITY	REFERENCE CODE
15	10	Base (Explosion Proof)	2810249062	1	
	20	Bushing, Bronze	2370112052	1	A, B, C, D, F, G
	20	Bushing	2370079152	1	E
	30	Seal	4080091020	1	A, B, C, D, F, G
	40	Motor (115 VAC, 224M)	2280032000	1	A, C, D, F, G
	40	Motor (115 VAC, 224N)	2280035000	1	B
	40	Motor (115 VAC, P-400)	2280039000	1	E
	40	Motor (220 VAC, 227D)	2280036000	1	A, C, D, F, G
	40	Motor (220 VAC, 227E)	2280034000	1	B
	40	Motor (220 VAC, P-400)	2280039010	1	E
	-	Jumper, Reverse Acting	40229	1	
	-	Wire, BLU, 22 gauge, P-400 only	4060387150	4 inch	
	50	Screw, No. 10-32 x 1/2	4050005063	4	
	55	Ground Screw, Green, Explosion Proof Only	4050306021	2	
	56	Ground Lug, Exp Proof Only	4913003001	2	A, B, C, D, F, G
	60	Adapter Plate	152067062	1	
	61	Shrink Tubing, 1/8	4911478040	2 inch	
	62	Resistor, 200 ohms, 115VAC	4910732003	1	A, B, C, D, F, G
	62	Resistor, 750 ohms, 220VAC	4910732014	1	A, B, C, D, F, G
	-63	Wire, BLU, 22 gauge	4060387150	7.5 inch	
	-64	Wire, YEL, 22 gauge	4060387140	9 inch	
	65	Cap., 4 UF, 115 VAC, 50/60 Hz	4913002000	1	A, B, C, D, F, G
	65	Cap., 4 UF, 220 VAC, 50 Hz	4913002000	1	E
	65	Cap., 1.5 UF, 220 VAC, 50/60 Hz	4913002001	1	A, B, C, D, F, G
	65	Cap, 15UF, 115VAC, 50/60 Hz	4910774008	1	E

- Items not shown.

FIGURE NUMBER	ITEM NUMBER	DESCRIPTION	PART NUMBER	QUANTITY	REFERENCE CODE
	-66	Mounting Base, Tie-Rap	4911494000	1	E
	-67	Tie-Rap	4060270030	2	E
	65	Cap., 3 UF, 220 VAC, 60 Hz	4910731003	1	E
	68	Connector (P3), AMP, 4 Pin	4910363003	1	
	-69	Wire, BRN	4060387160	7 inch	E
	-69	Wire, ORN	4060387170	7 inch	E
	70	Washer, Spring Lock, No. 8	4040121022	3	
	80	Circuit Board Standoff	152065162	3	
	90	Potentiometer Assembly (Includes Items 100, 101, 102, 103 (18 Teeth), 104, 105, 106, 107, 108, Pot. 10Turns)	0152070101	1	F
	90	Potentiometer Assembly Includes Items 100, 101, 102, 103 (32 Teeth), 104, 105, 106, 107, 108, Pot. (1 Turn)	152070102	1	B, C
	90	Potentiometer Assembly Includes Items 100, 101, 102, 103 (32 Teeth), 104, 105, 106, 107, 108, Pot. (10 Turns),	152070103	1	A, D, E, G
	100	Bracket, Potentiometer	152068062	1	
	-101	Potentiometer	4911121010	1	A, D, E, F, G
	-101	Potentiometer	4911121002	1	B, C
	-102	Wire, BLK & WHT, 22 gauge	4060387111	7 inch	
	-103	Gear, 18 Teeth	151759033	1	F
	-103	Gear, 32 Teeth	4100167013	1	A, B, C, D, E, G
	-104	Wire, RED & WHT, 22 gauge	4060387103	7 inch	
	-105	Wire, GRY, 22 gauge	4060387180	7 inch	
	-106	Pin, Spring, 0.062 x 3/8	4010001041	1	F
	-107	Shrink Tubing, 1/8	4911478040	3 inch	
	108	Connector (P2), AMP, 3 Pin	4910363002	1	
	-109	Washer, Plastic	4911303003	1	
	110	Washer, Spring Lock, No. 4	4040095023	2	
	120	Screw, No. 4-40 x 3/16	4052010000	2	
	140	Screw, No. 6-32 x 7/16	4050264031	2	
	145	Washer, Lock, No. 6	4040104071	2	

- Items not shown.

FIGURE NUMBER	ITEM NUMBER	DESCRIPTION	PART NUMBER	QUANTITY	REFERENCE CODE
	150	Connector (P1), AMP, 9 Pin	4910363008	1	
	160	Ties, Cable	4060270010		
	170	Identification Plate, Terminal	152097099	1	
	180	Square Ring Seal	4080133440	1	
	190	Gear, Worm, Single Lead	151984001	1	A, B, C, D, E, G
	190	Gear, Worm, Double Lead	151984002	1	F
	200	Pin, Spring, 3/32 x 1/2	4010002052		
	220	Circuit Board (115 VAC, 230 VAC, 50/60 Hz), Specify Pump	30300	1	A, B, C, D, F, G
	220	Circuit Board (115 VAC, 230 VAC, 50/60 Hz), Specify Pump	39320		E
	280	Cover, Short	2810248362	1	A, B, C, D, F, G
	280	Cover, Tall	2810248462	1	E
	290	Bushing, Bronze	152199052	1	
	300	Shaft, Hand Wheel	152082414	1	A, B, C, D, F, G
	300	Shaft, Hand Wheel	2680059014	1	E
	310	O-ring, 0.239 x 0.070, BUNA	4080109071	1	
	320	Spring	4030125042	1	
	340	Clip, Retaining	4040107135	1	
	350	Knob, Hand	2550039000	1	
	360	Pin, Spring, 0.125 x 1-1/4	4010003132	1	
	370	Label, Explosion	2530214000	1	
	370	Label, NEMA 4	2530209062	1	
	-380	Shaft, Drive Coupling	2520148006	1	E
	-385	Pin, Spring, 1/8 x 5/8	4910764006	1	A, C, D, E, F, G
	390	Rivet	4050087021	2	
	400	Plug	4020009137	2	
	410	Gearbox(20:1) Double Stage	21523	1	A, C, D, G
	410	Gearbox, Single (5:1)	CALL FACTORY	1	F(Low Pressure)
	410	Gearbox(12:1) Double Stage	CALL FACTORY	1	F(High Pressure)
	510	Connector (P4), 2 Position Phoenix	4911499060	1	
	520	Connector (P5), 4 Position Phoenix	4911499050	1	

- Items not shown.

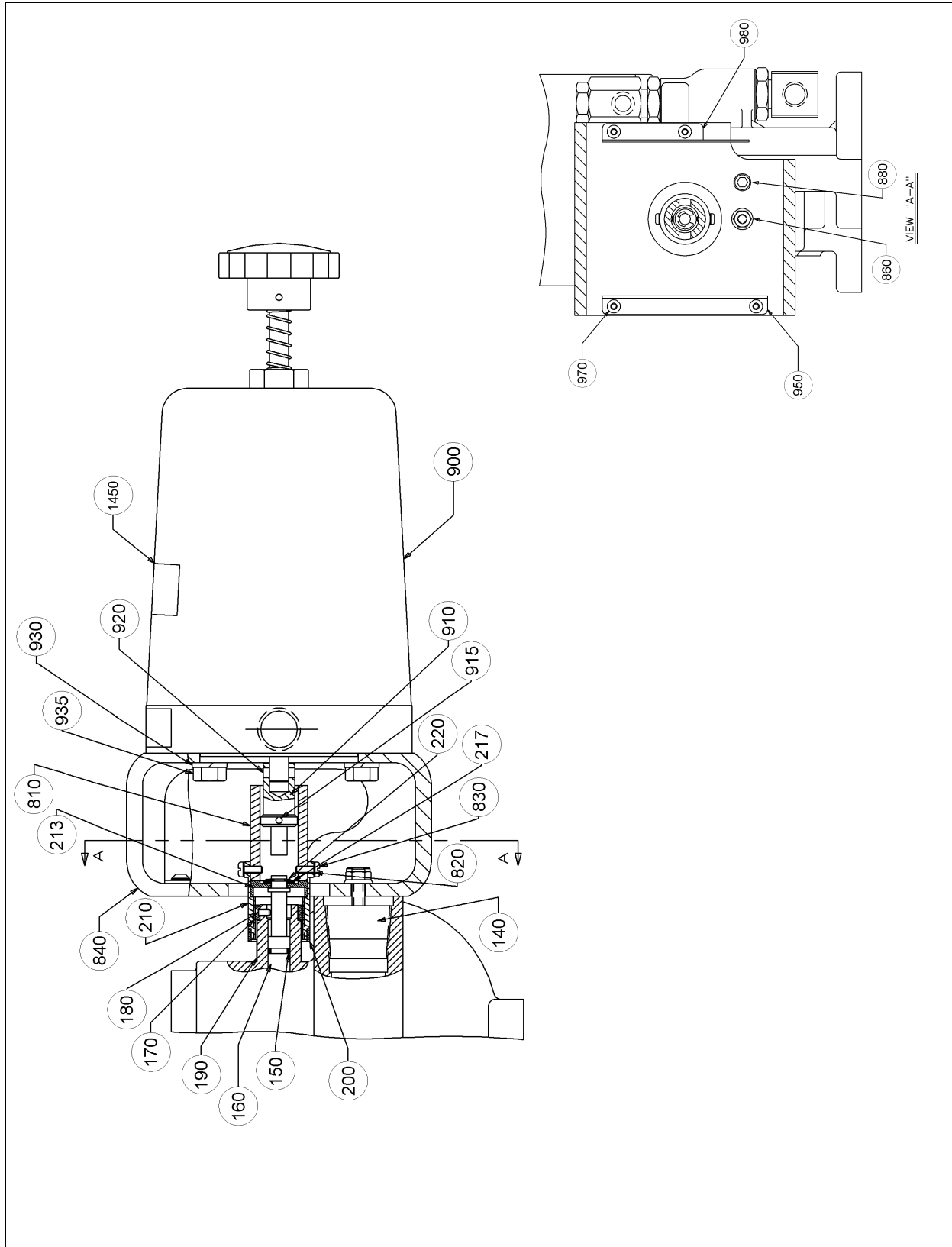

Figure 16. mRoy "A" ECC Mounting Adapter (DWG. 1021971000).

6.4 PARTS LIST FOR MROY ECC MOUNTING ADAPTER

Model: mRoy "A"

FIGURE NUMBER	ITEM NUMBER	DESCRIPTION	PART NUMBER	QUANTITY	REF CODE
16	-	Kit, ECC Retrofit, RT, RH, & RJ Plunger, Includes Wrench	30268	1	
	-	Kit, ECC Retrofit, RA & RP Plunger, Includes Wrench	30280	1	
	140	Plug Assembly, Adapter 1" NPT	2430045020	1	
	140	Plug Assembly, Adapter 1/2" NPT	2430045000	1	
	150	O-Ring, Cont. Spool, Urethane 2-113	4080109082	3	
	160	Spool, Control	2680037006	1	
	170	Sleeve, Threaded - 316ss	2430058016	1	
	180	Screw, Socket Set, 06-32NC x 1/4	4050039035	1	
	190	Plate, % Capacity - Aluminum	2530015062	1	
	200	Ring, Calibration - Aluminum	2530024062	1	
	210	Knob, Capacity Adjustment	2550035077	1	
	213	Bearing, Control Spool	2370076052	1	
	217	Washer, Thrust - 5/16 Steel	4040147031	1	
	810	Coupling, Drive	2520138077	1	
	820	Lockwasher, Drive Coupling #6 Internal Tooth	4040104071	2	
	830	Screw, Drive Coupling Pan Head 6-32 x 3/8	4050178033	2	
	840	Bracket, Mounting	2040149006	1	
	860	Nut, Serrated Flange 1/4-20NC	4050323036	1	
	880	Screw, Socket Head 5/16-18 x 5/8	4050157024	1	
	900	ECC	See Table 2	1	
	910	Shaft, Drive	2680052077	1	
	910	Shaft Assembly, Drive: Includes Items 910, 915, & 920	2680055000	1	
	915	Pin, Drive Shaft 1/8x1-1/8	4010021133	1	
	920	Pin, Drive Shaft Spring.187x5/8	4010005032	1	
	930	Lockwasher, Spring 3/8	4040041022	4	
	935	Bolt, Hex Head 3/8-16 x 3/4 Lg.	4050018096	4	
	950	Sideguard, Left	2490110006	1	
	960	Sideguard, Right	2490109006	1	
	970	Screw, Button Head - 10-32 x 5/16	4050282087	4	
	1450	Label, Warning	2530097000	1	

- Items not shown.

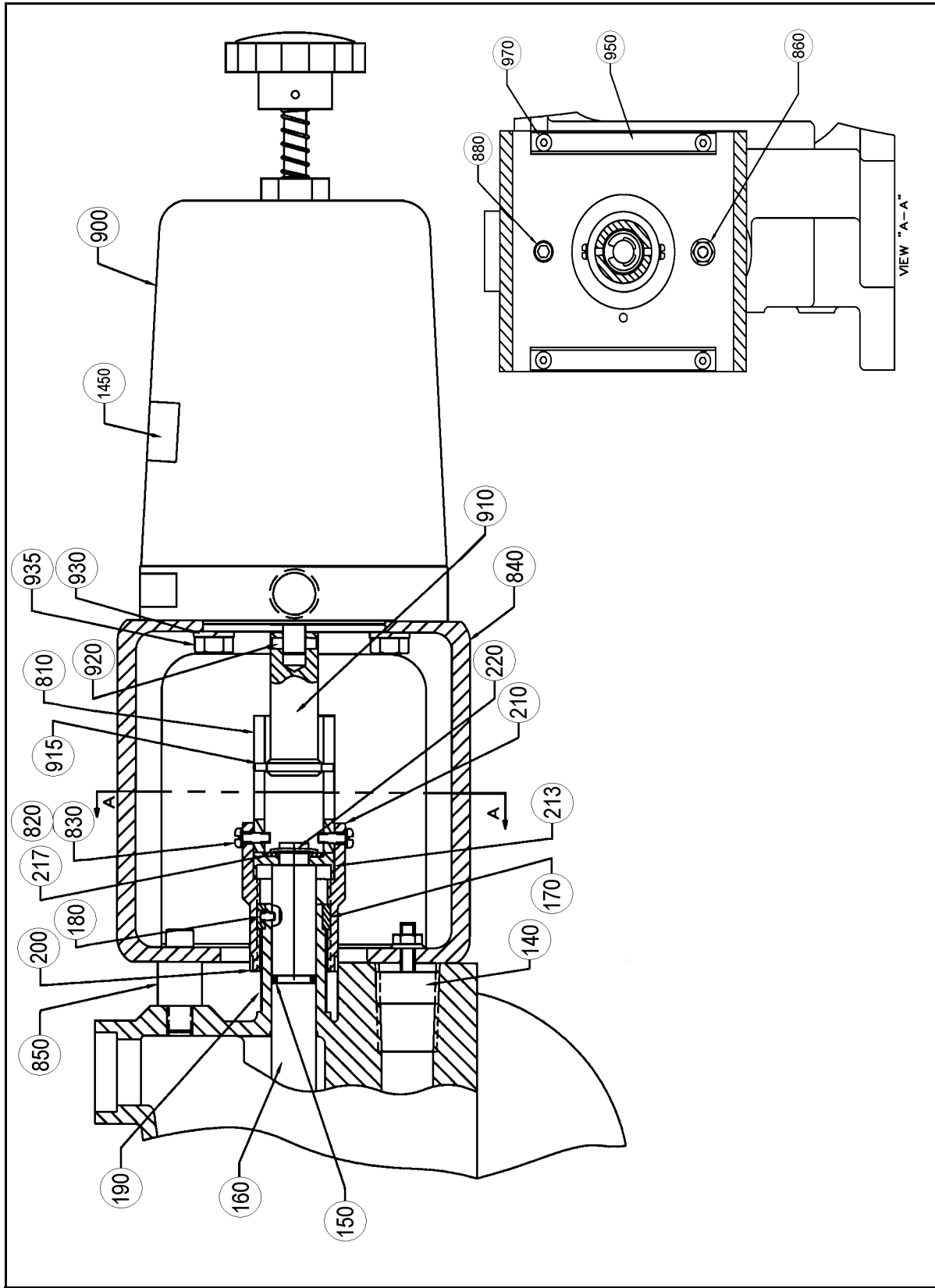

Figure 17. mRoy "B" ECC Mounting Adapter (DWG 10221460003).

6.5 PARTS LIST FOR MROY ECC MOUNTING ADAPTER

Model: mRoy "B"

FIGURE NUMBER	ITEM NUMBER	DESCRIPTION	PART NUMBER	QUANTITY	REF CODE
17	-	Kit, ECC Retrofit -19/32 Plunger	3351402020	1	
	-	Kit, ECC Retrofit -7/8 Plunger	3351402030	1	
	-	Kit, ECC Retrofit - 1-7/16 Plunger	3351402040	1	
	140	Plug Assembly, Adapter 1-1/4" NPT, 1-7/16 Plunger	2430045030	1	
	140	Plug Assembly, Adapter 3/4" NPT, 19/32 and 7/8 Plunger	2430045010	1	
	150	O-Ring, Cont. Spool, 2-011 Urethane	4080068032	3	
	160	Spool, Control	2680049006	1	
	170	Sleeve, Threaded	2430059051	1	
	180	Screw, Socket Set 6-32NCx1/4	4050039035	1	
	190	Decal, Capacity	2530026062	1	
	200	Ring, Calibration - Aluminum	2530025062	1	
	210	Knob, Capacity Adjust - Delrin	2550036077	1	
	213	Bearing, Control Spool	2370075052	1	
	217	Washer, Thrust 1/2" - Steel	4040147051	1	
	220	Clip, E-Ring External 4049983151		1	
	810	Coupling, Drive	2520120077	1	
	820	Lock-Washer, Internal Tooth #8	4040104082	2	
	830	Screw, Pan Hd #8-32NC x 1/2"	4050179073	2	
	840	Bracket, Mounting - Steel	2040148006	1	
	850	Stud, Mounting	2320033006	1	
	860	Nut, Serrated Flange 1/4-20NC	4050323036	1	
	880	Screw, Socket Head 5/16"-18x5/8	4050157024	1	
	900	ECC	See Table 2	1	
	910	Shaft Assembly, Drive: Includes Items 910, 915 & 920	2680054000	1	
	910	Shaft, Drive - Delrin	2680053077	1	
	915	Pin, Dowel 1/8 x 1-3/8 Steel	4010021143	1	
	920	Pin, Spring 0.187 x 13/16 CRS	4010005062	1	
	930	Lock-Washer, Spring 3/8"	4040041022	4	
	935	Screw, Hex Hd 3/8-16 x 3/4	4050018096	4	
	950	Guards, Side	2490108006	2	
	970	Screw, Bottom Head #10-32x 5/16	4050282087	4	
	1450	Label, Warning	2530097000	1	

- Items not shown.

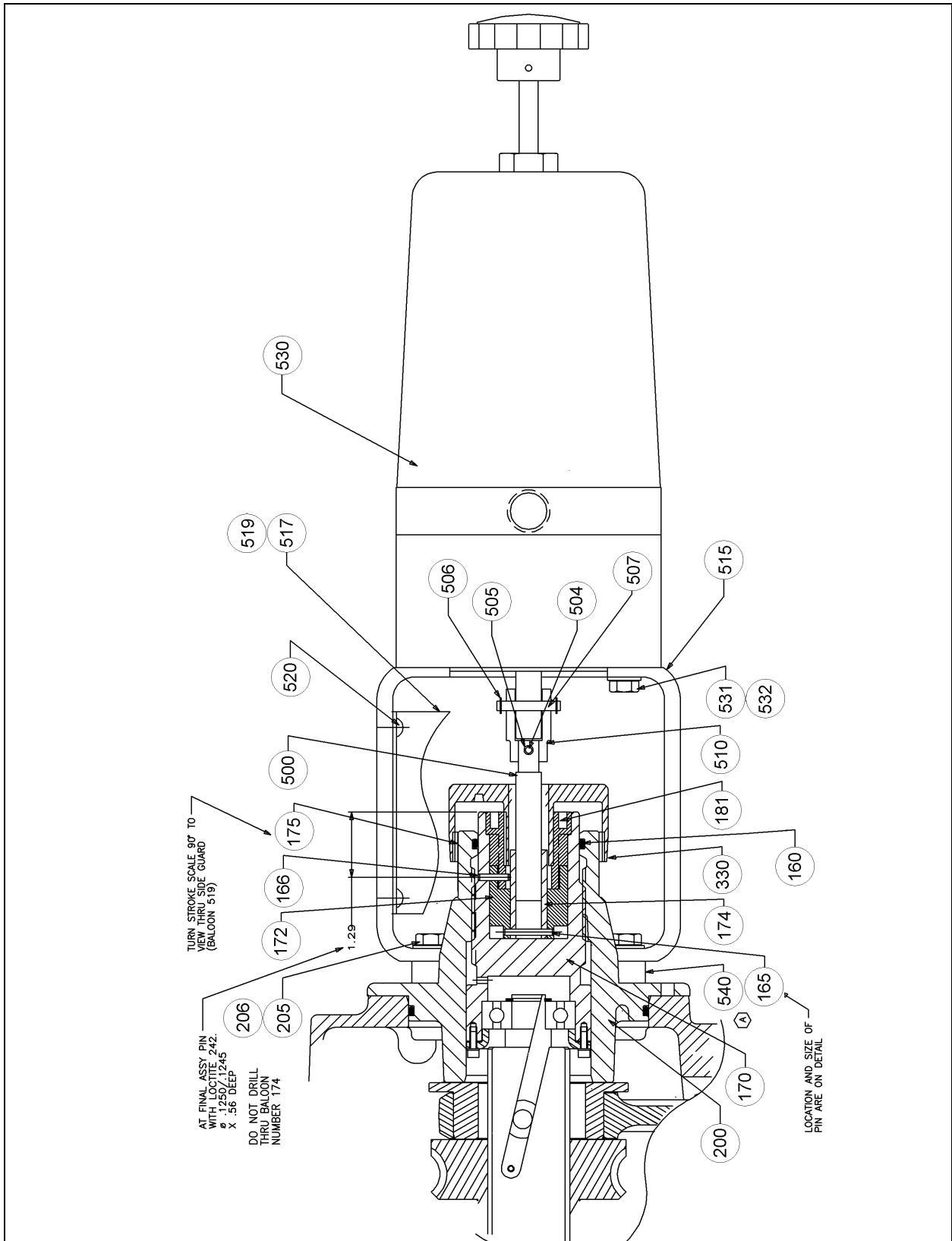

Figure 18 (Sheet 1 of 2). MacRoy "G" ECC Mounting Adapter (DWG. 1022118000)
Design through "September 2004" and Milroyal "G".

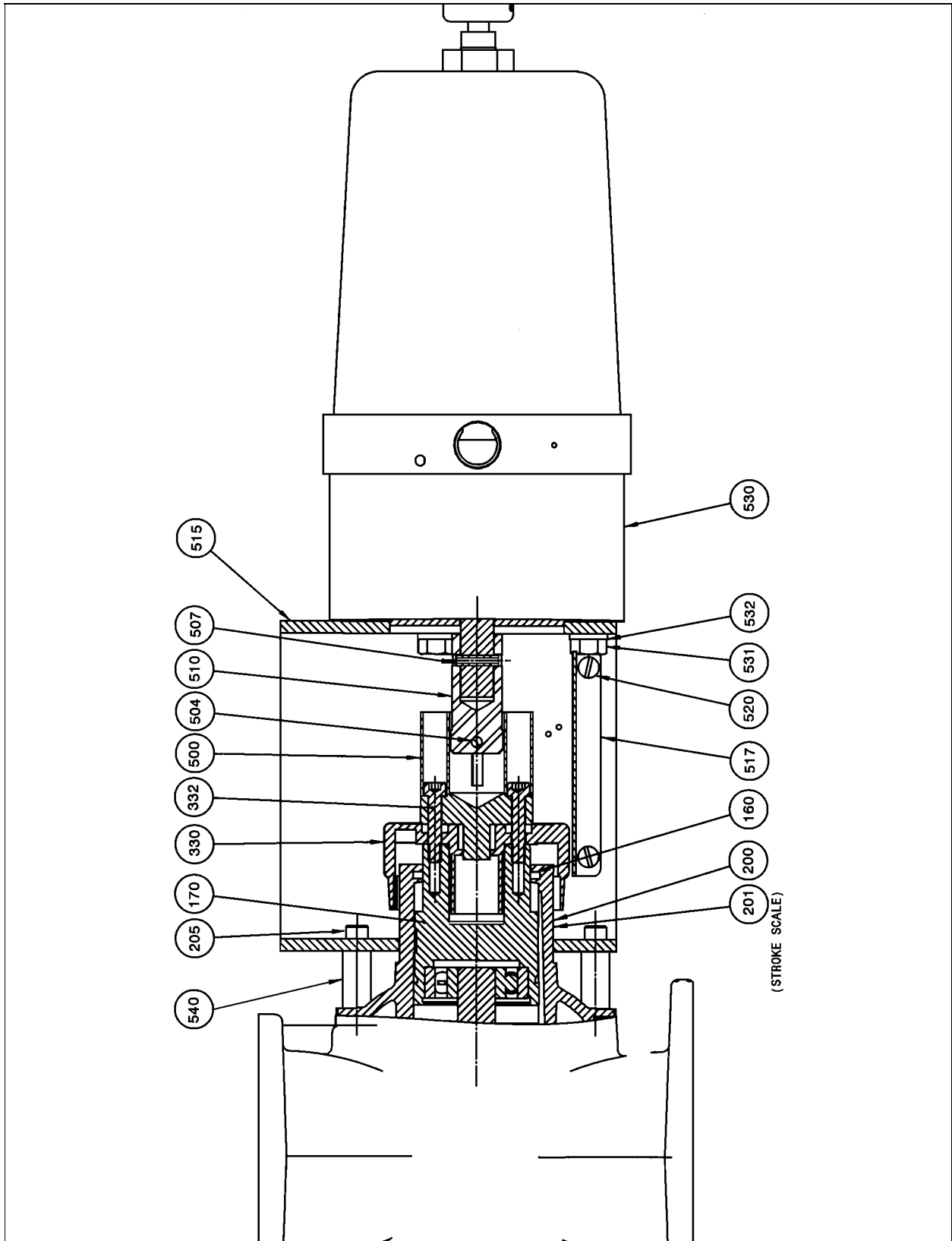

Figure 18 (Sheet 2 of 2). MacRoy "D" ECC Mounting (DWG. 1022728000)

6.6 PARTS LIST FOR MACROY ECC MOUNTING ADAPTER

Model: Code: _____ Model: Code _____:
 MacRoy "G" A MacRoy "D" C
 Milroyal "G" B

FIGURE NUMBER	ITEM NUMBER	DESCRIPTION	PART NUMBER	QUANTITY	REFERENCE CODE
18	-	Kit, ECC Retrofit Mount Mil G	20625	1	B
	160	O-Ring, 1.984 x 0.139, Buna N	4080095171	1	A, B, C
	-	Stroke Screw Assy, See Note	60293	1	A, B
	165	Pin, Spring	4910764012	1	A, B
	166	Pin, Dowel, See Note	4010021030	1	A, B
	-	Screw, Socket Hd, 6-32NC x 3/8, See Note	4050204034	4	A, B
	-	Screw, Stroke Adjust, See Note	60948	1	A, B
	-	Retainer, Bearing, See Note	60949	1	A, B
	170	Screw, Stroke Adjust, See Note	60442	1	A, B
	170	Screw, Stroke Adjust	61261	1	C
	172	Plug, Stroke, See Note	60283	1	A, B
	174	Sleeve, Shaft, See Note	60284	1	A, B
	175	Scale, Stroke	2530046062	1	A, B
	181	Insert, Stroke Screw, See Note	60285	1	A, B
	190	O-Ring, Parker 2-246, Buna N	4080095371	1	A, B
	200	Cover	60986	1	A, B
	200	Cover	61255	1	C
	201	Scale, Stroke	61268	1	C
	205	Screw, Socket Hd M8 x 35 mm	4350035542	4	A, B
	205	Screw, Socket Hd M6 x 45 mm	41567	3	C
	206	Lock-washer, Spring 8 mm	4340009002	4	A, B
	320	Screw, Socket Set M6 x 6 mm	41067	1	C
	330	Knob, Stroke Adjust	60286	1	A, B
	332	Screw, Socket Hd M6 x 30 mm	4350047395N	2	C
	500	Rod, Stroke Drive	60287	1	A, B
	500	Coupling, Drive - D/SD ECC	61247	1	C
	504	Pin, Connecting	60290	1	A, B
	504	Pin, Dowel, 3/16 X 2	4010022082	1	C
	505	Ring, Retaining	40203	2	A, B

- Item not shown.

FIGURE NUMBER	ITEM NUMBER	DESCRIPTION	PART NUMBER	QUANTITY	REFERENCE CODE
	506	Ring, Retaining	40204	2	A, B
	507	Pin, Connecting	60971	1	A, B
	510	Coupling	60970	1	A, B
	510	Shaft, Drive	2680063062	1	C
	510	Coupling, Drive Shaft	61123	1	C
	515	Bracket, Mounting	60289	1	A, B
	515	Bracket, Mounting	61245	1	C
	517	Guard, Side	2490108006	1	A, B
	517	Guard, Modified	61244	1	C
	519	Guard, Modified Side (Slotted)	60292	1	A, B
	520	Screw	4050282087	4	A, B
	520	Screw, Btn Hd Soc, #10-32X3/8	4050282027	2	C
	530	ECC	See Table 8	1	A, B, C
	531	Screw, Hex Hd 3/8-16 x 3/4	4050018096	4	A, B, C
	532	Lock-washer, Spring 3/8	4040041022	4	A, B, C
	540	Spacer MIL G Act Mtg Bracket	60985	4	A, B
	540	Standoff - D/SD ECC	61246	3	C

- Item not shown.

NOTE Part not sold separately. Replacement requires purchase of "GB ECC Stroke Screw Assembly" (part number 60293) made up of items: 165, 166, 170, 172, 174, and 181.

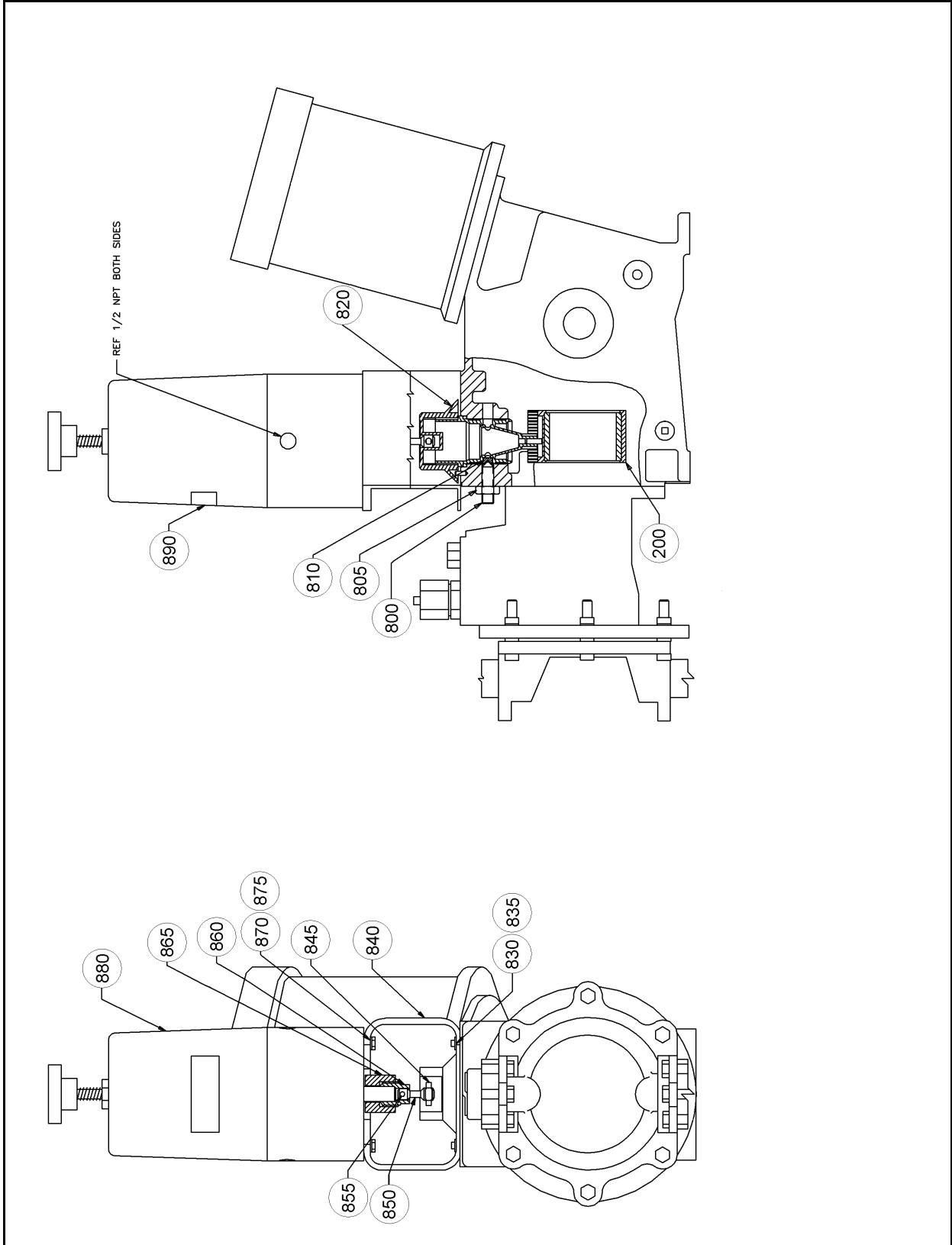

Figure 19. maxRoy B ECC Mounting Adapter (DWG. 1021572000).

6.7 PARTS LIST FOR MAXROY ECC MOUNTING ADAPTER

Model: maxRoy "B"

FIGURE NUMBER	ITEM NUMBER	DESCRIPTION	PART NUMBER	QUANTITY	REFERENCE CODE
19	-	Kit, ECC Retrofit Mount, Includes The Following Parts: Items 200 Through 890	PARTSKIT303	1	
	200	Stroke Adjustment Sleeve	60680179006	1	
	800	Set Screw M-12 x 40	64350068535	1	
	805	Hex Nut M-12	64350000085	1	
	810	Shoe	60190269062	1	
	820	Basic Stroke Adjustment Assembly, (Sold as a Kit) Includes the following:	63050654010	1	
		Pin, Spring 0.156 x 7/16	4010004012	1	
		O-ring, 2-223, Buna N	4080095141	1	
		Knob, Stroke Indicator	60550026077	1	
		Drum, Control	60550047074	1	
		Ring, MAXROY B	64400002021	2	
		Lubricant, O-ring	4070311000	1	
	830	Lockwasher, Metric for #6 Screw	4040150091	3	
	835	Screw, Socket HD Metric #6	4052003021	3	
	840	Mounting Bracket	2040151006	1	
	845	Pin, ECC, MAXROY B	2110057052	1	
	850	Link, MAXROY B	2140029006	1	
	855	Dowel Pin 3/16 x 1" Lg.	4010022051	1	
	860	Coupling	2520128000	1	
	865	Coupling Nut	2090034006	1	
	870	Lockwasher 3/8 Med.	4040041022	4	
	875	Screw, Hex Hd 3/8 Med.	4050018096	4	
	880	ECC	See Table 3	1	
	890	Label, Warning	2530097000	1	

- Items not shown.

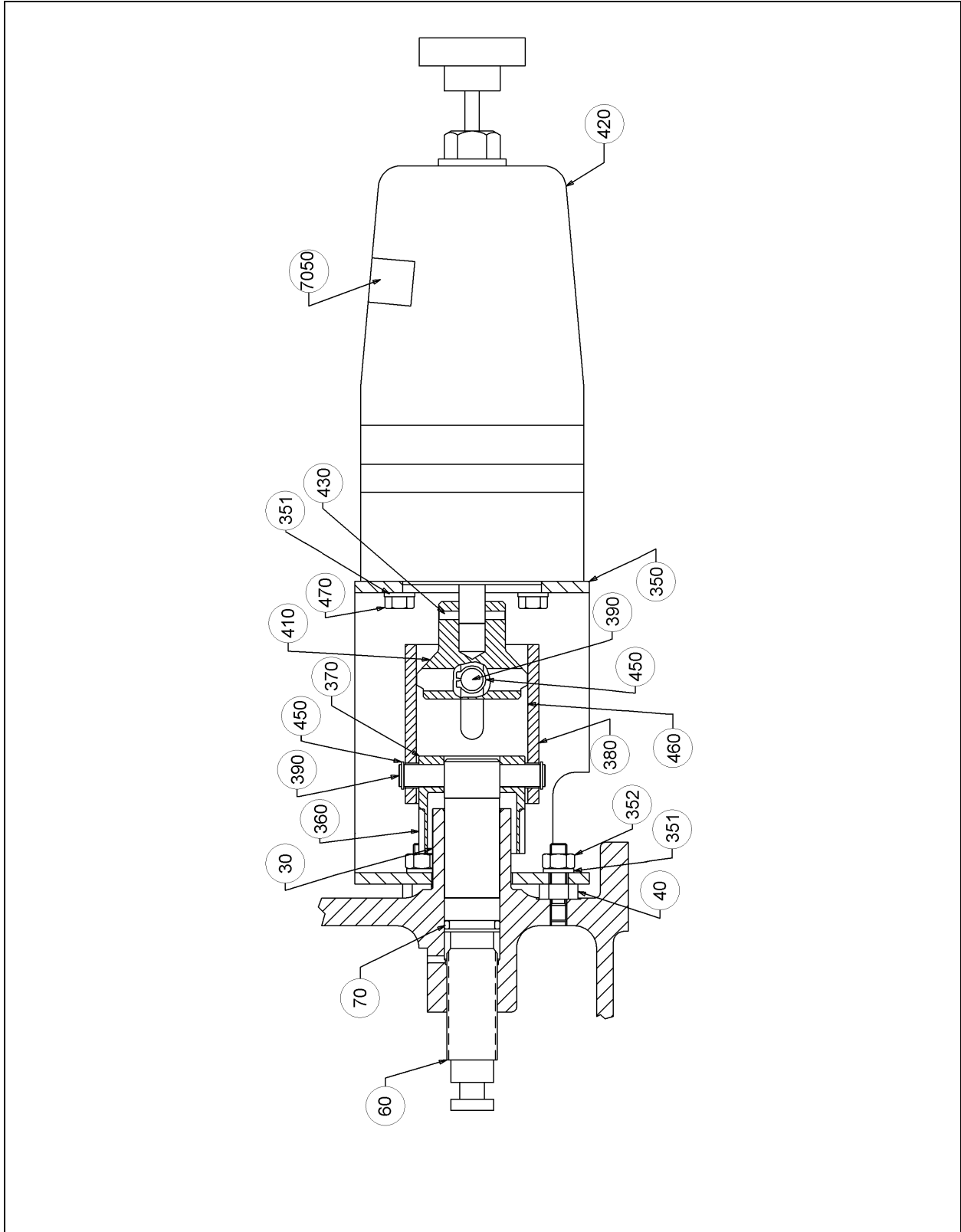

Figure 20 (Sheet 1 of 2). Milroyal B ECC Mounting Adapter (DWG. 1022095000).

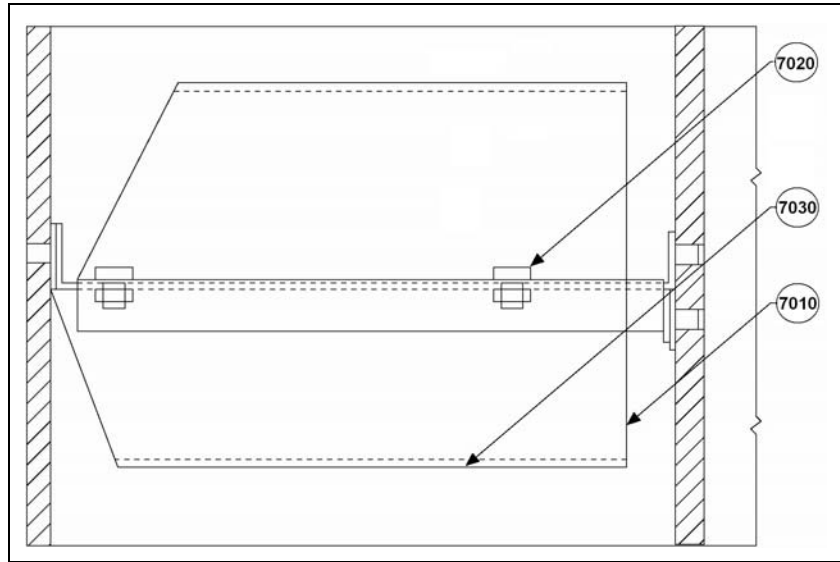

Figure 20 (Sheet 2 of 2). Milroyal B ECC Mounting Adapter Guard Assembly (DWG. 1022095000).

THIS PAGE INTENTIONALLY BLANK

6.8 PARTS LIST FOR MILROYAL ECC MOUNTING ADAPTER AND MOUNTING ADAPTER GUARD ASSEMBLY

Model: Milroyal "B"

FIGURE NUMBER	ITEM NUMBER	DESCRIPTION	PART NUMBER	QUANTITY	REFERENCE CODE
20A/B	-	Kit, ECC Retrofit Mount, Includes The Following Parts: Items 30 Through 7050	20270	1	
	30	Stroke Indicator	2530110062	1	
	40	Stud; 3/8-16 NC x 1-1/2 S/S	2430061014	3	
	60	Lead Screw	2560001006	1	
	70	Crown Seal; Fluorotrel Seal Element & Nitrile O-Ring	4080123151	1	
	350	Mounting Bracket	2040150006	1	
	351	Lockwasher; 3/8 Medium C/S	4040041022	7	
	352	Nut; 3/8-16 NC, S/S	4050066012	3	
	360	Indicator Ring	2190088062	1	
	370	Indicator Knob	2550037014	1	
	380	Coupling	2520121006	1	
	390	Bearing Pin	2110056052	2	
	410	Drive Collar	2180002015	1	
	420	ECC	See Table 4	1	
	430	Dowel Pin; 3/16 x 1/2 Long	4010022061	1	
	450	E-Ring; Waldes # 5160-50	4040133040	4	
	460	Grease; Mobile # CM-P	4070309000	A/R	
	470	Screw; Hex Hd 3/8-16 Unc x 3/4 Lg.	4050018096	4	
	7010	Upper Guard	2490112006	1	
	7020	Screws; Pan Hd # 10-32 x 5/16 Lg.	4050282087	4	
	7030	Lower Guard	2490111006	1	
	7050	Warning Label	2530097000	1	
	-	Loctite Hydraulic Sealant	4070123009	A/R	

- Items not shown.

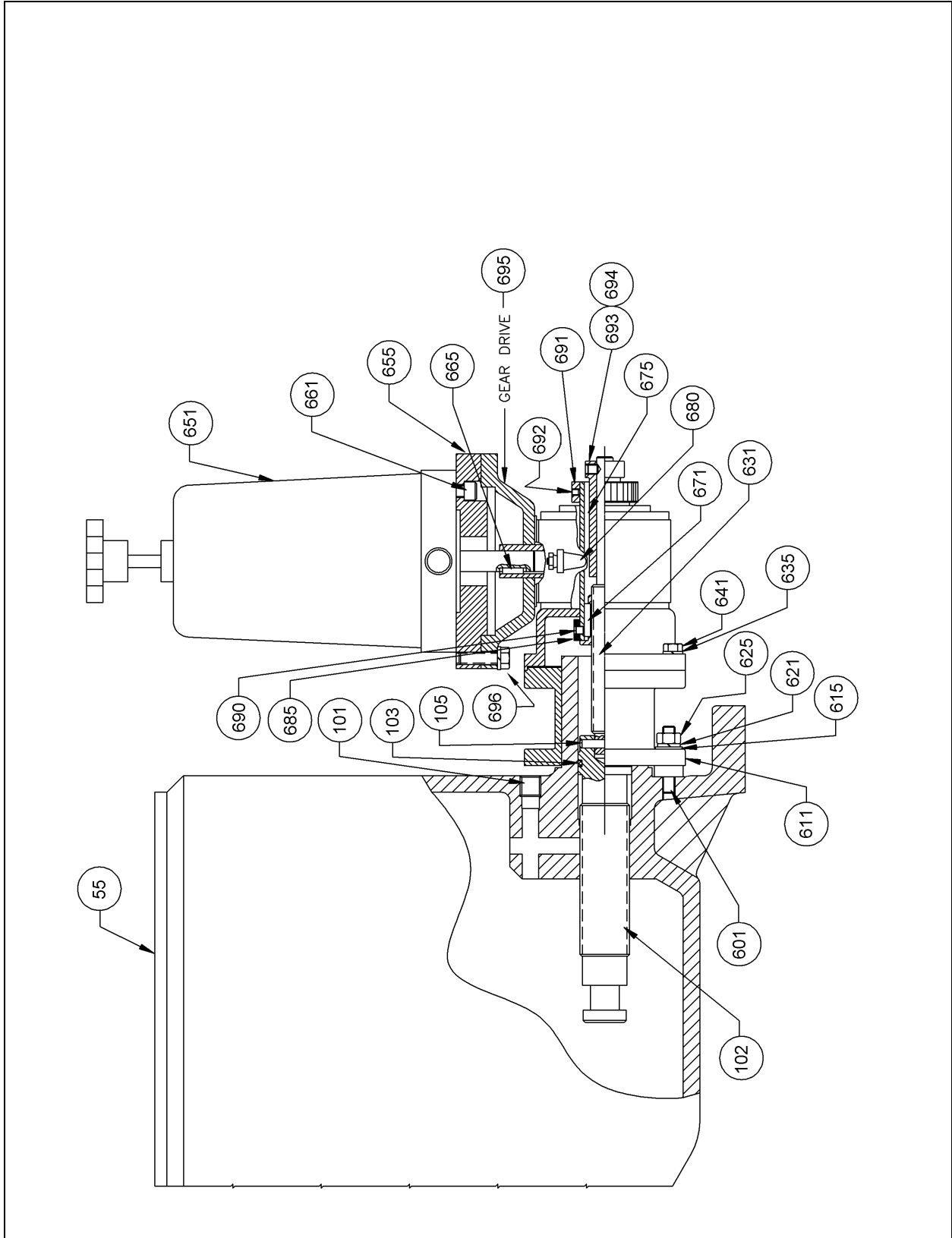

Figure 21. Milroyal C ECC Mounting Adapter (DWG. 10222850002).

6.9 PARTS LIST FOR MILROYAL ECC MOUNTING ADAPTER AND GEAR DRIVE

Model: Milroyal "C"

FIGURE NUMBER	ITEM NUMBER	DESCRIPTION	PART NUMBER	QUANTITY	REFERENCE CODE
21	-	Kit, ECC Retrofit Mount, (Manual Adjust to ECC Mount) Includes Items 101 thru 631, Before 1990	30270		
	-	Kit, ECC Retrofit Mount, (Manual Adjust to ECC Mount) Includes Items 101 thru 631, 675, 693, & 694, After 1990	39647		
	101	Set Screw 5/8-11" x 1 Lg.	4050047054	1	
	102	Lead Screw	2560059006	1	
	103	Seal	4080123211	1	
	105	Dowel Pin	4010023072	1	
	601	Stud 3/8-16" x 2 Lg.	2430061014	3	
	611	Adapter	2720116062	1	
	615	Flatwasher 3/8"	4040009012	3	
	621	Lockwasher 3/8"	4040041022	3	
	625	Hex Nut 3/8"	4050066012	3	
	631	Spline Shaft	2520147006	1	
	-	Gear Parts, Includes The Following Parts: Items 635 Through 696		1	
	635	Lockwasher 5/16"	4040040028	4	
	641	Hex Hd. Cap Screw 5/16-18" x 1 Lg.	4050017116	4	
	651	ECC, Includes ECC and Gearbox without Lead Screw	See Table 5		
	655	Adapter Plate	2720115062	1	
	661	Soc. Hd. Cap Screw 3/8-16" x 5/8 Lg.	4050029086	4	
	665	Key	4040056031	1	
	671	Key	2110058006	1	
	675	Indicator, Tube	2450029062	1	
	675	Indicator, Tube Decal, Part of P/N 39647	2530121062	1	
	680	Street Elbow	4020031011	1	
	685	Spline Bushing	2370091006	1	

- Items not shown.

FIGURE NUMBER	ITEM NUMBER	DESCRIPTION	PART NUMBER	QUANTITY	REFERENCE CODE
	691	Indicator Ring Assy, Includes:	2190099000	1	
	691	Ring, Indicator	2190096062	1	
	691	Decal	2530122062	1	
	692	Set Screw 10-32 x 1/4 Lg.	4050042025	2	
	693	Indicator Tube Assy, Includes: Item 675	2450030000	1	
	693	Decal	2530121062	1	
	693	Indicator Tube, Part of P/N 39647	2450029062	1	
	694	Set Screw 5/16-18" x 5/16 Lg.	4050044025	2	
	695	Gearbox, without ECC & Lead Screw	2280038000	1	
	696	Hex Hd Cap. Screw 3/8-16" x 1 Lg.	4050018119	2	
	-	Grease	407-0309-000	A/R	
	-	Loctite # 242	407-0123-905	A/R	
	-	Loctite Hyd. Sealant	407-0123-009	A/R	

- Items not shown.

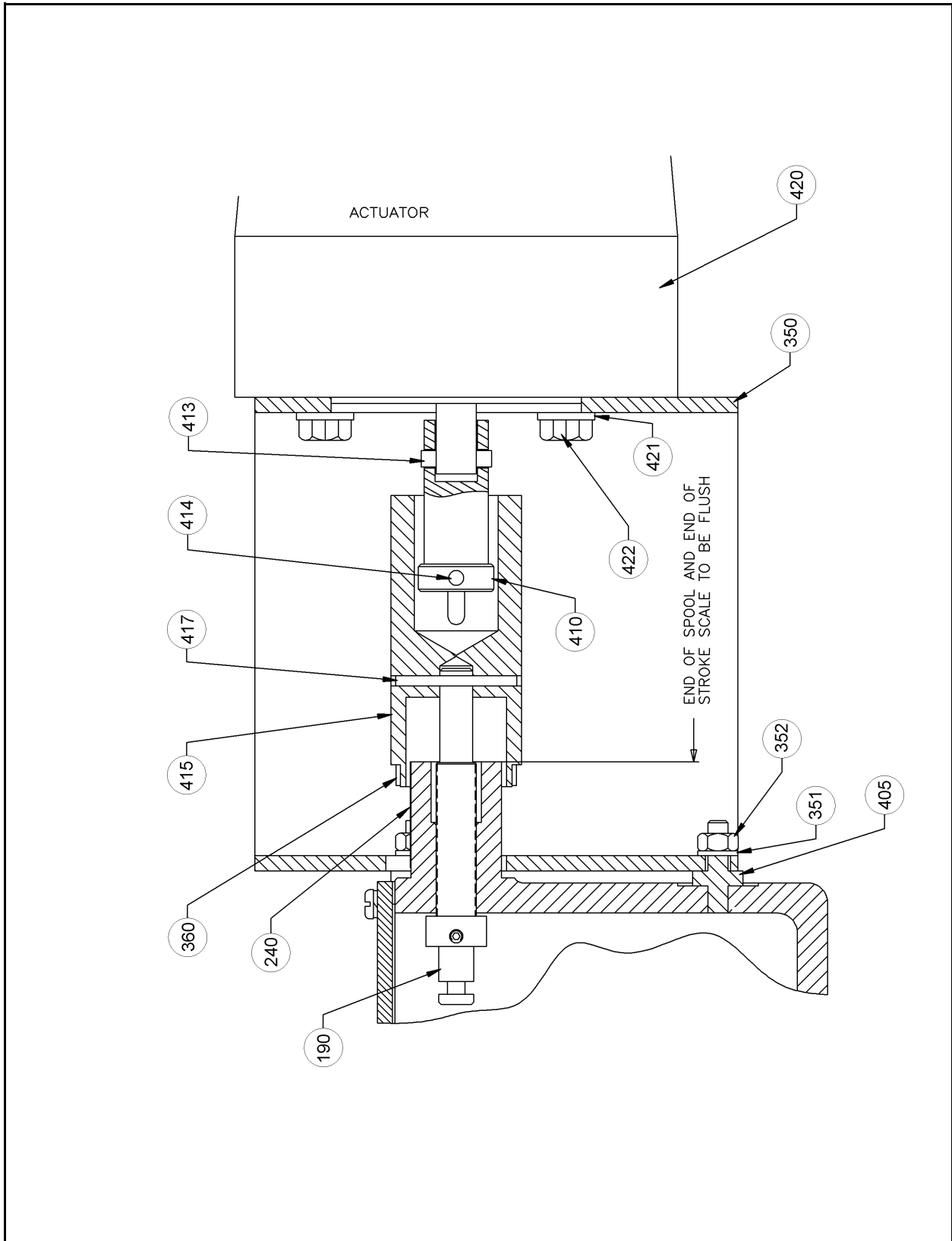

Figure 22. Milroyal D ECC Mounting Adapter (DWG. 1022906000).

6.10 PARTS LIST FOR MILROYAL ECC MOUNTING

Model: Milroyal "D"

MOUNTING PARTS LIST

FIGURE NUMBER	ITEM NUMBER	DESCRIPTION	PART NUMBER	QUANTITY	REFERENCE CODE
22	-	Kit, ECC Retrofit Mount	30265	1	
	190	Screw, Lead	2560027006	1	
	240	Scale, Stroke	2530046000	1	
	350	Bracket, Mounting	2040187006	1	
	351	Lock-washer, Spring	4040039022	4	
	352	Nut, Hex 1/4 - 20NC	4050064012	4	
	360	Ring, Calibration, Aluminum	2530025062	1	
	405	Stud, Mounting	2320034006	4	
	410	Shaft, Drive	2680063062	1	
	413	Pin, Spring 0.187 x 13 x 16	4010005062	1	
	414	Pin, Dowel 3/16 x 1-3/4	4010022072	1	
	415	Coupling, Drive	2520154077	1	
	417	Pin, Spring 0.125 x 1-1/2	4010003152	1	
	420	ECC	See Table 6	1	
	421	Lock-washer, Spring 3/8	4040041022	4	
	422	Screw, Hex HD 3/8-16 x 3/4	4050018096	4	

- Items not shown.

THIS PAGE INTENTIONALLY BLANK

APPENDIX A

A.1 MAXROY B PUMP ECC FIELD INSTALLATION (RETROFIT) (FIGURE 19)

This section applies to field mounting the ECC on a manually adjusted maxRoy pump. Refer to Figure 8 in manual 3390005000. Installing the ECC to a maxRoy B pump requires mechanically mounting the ECC and performing the ECC calibration procedures.

1. Remove nameplate (Figure 8, BN, 3390005000) from capacity control knob (BO) exposing the keyway socket in the top of the knob. Adjust knob to 100% capacity setting.
2. Leave stroke locking handle (BK) loose.
3. Mount bracket onto pump housing 3 bolts and lockwashers (Figure 19, 830 & 835).
4. Assemble dowel pin (855) (press fit) and brass drive pin (845) (slip fit) into the link (850). Insert the assembled link into the capacity control knob keyway. The drive pin side of the link fits into the slot in the top of the knob.
5. Loosely assemble the coupling (860) and coupling nut (865). Assemble the coupling to the link. The drive pin of the link fits into the coupling slot.

CAUTION

IMPROPER CONNECTION OF THE POWER LINE OR INCORRECT SUPPLY VOLTAGE CAN CAUSE DAMAGE TO

THE ECC. DISCONNECT ALL POWER BEFORE CONNECTING WIRES.

6. Connect electrical connections, Paragraph 2.6.

WARNING

YOU WILL BE MAKING ADJUSTMENTS TO THE ECC CONTROL CIRCUIT BOARD WHILE IT IS POWERED UP. THIS CONTROL BOARD IS POWERED BY POTENTIALLY DANGEROUS VOLTAGE (115 OR 230 V AC). THE CALIBRATION PROCEDURE IS TO BE PERFORMED ONLY BY QUALIFIED PERSONNEL FAMILIAR WITH THE HAZARDS INHERENT WORKING NEAR HIGH VOLTAGES. MILTON ROY ASSUMES NO RESPONSIBILITIES FOR DAMAGE TO EQUIPMENT OR INJURY TO PERSONNEL WHILE PERFORMING THIS CALIBRATION PROCEDURE.

7. Perform calibration B, Paragraph 4.8.1.2.
8. Mount the ECC onto the mounting bracket. The ECC shaft should slip into the coupling nut bore. (If the shaft does not slide easily into the bore, loosen the coupling nut.) Fasten the ECC to the bracket with the four bolts and lockwashers (870 & 875).
9. Tighten the coupling nut to the coupling using two wrenches (40 ft-lbs), being careful not to change the pump capacity setting or move the ECC shaft.

THIS PAGE INTENTIONALLY BLANK

APPENDIX B

B.1 MILROYAL B PUMP FIELD INSTALLATION (RETROFIT)

The Milroyal B electronic capacity control is available in kit form for field retrofit to an existing Milroyal B with manual stroke adjustment. The Milroyal B ECC retrofit consists of:

- ECC & worm gear speed reducer assembly
- Lead screw with splined shaft
- Adapter
- Hardware and mounting screws

Please refer to instruction manual 3390007000 as well as this manual. Refer to Section 6, "Parts List", Figure 20 as needed.

B.2 GENERAL

The following instructions pertain to pumps manufactured after 1988 only. Pumps manufactured prior to 1988 can not be retrofitted with the ECC.

The simplest way to determine if your pump can be fitted with an ECC is to examine the back end carefully. Pump casings manufactured after 1988 have thicker pump housing walls and three mounting holes. These mounting holes are factory machine spot faced, drilled and tapped, with hole plugs installed.

If your pump has these mounting holes, it can be retrofitted to ECC operation. The following supplies will be needed to begin the retrofit process:

- (1) ECC (see Table 4 for ECC models)
- (1) ECC mounting kit # 20270, RTV, & Loctite Sealant

B.2.1 Removal of Existing Pump Capacity Adjustment

Refer to instruction manual 3390007000, Figures 9 & 10.

1. Drain oil from pump drive in preparation for removal of existing micrometer capacity adjustment.
2. Adjust micrometer knob to 0% setting.

3. Working from the bottom of the gear housing (281-A), loosen the two set screws (405-AL) and slide aside the two lead screw keys (211-A). This will free up the lead screw (256-A).
4. Rotate the micrometer knob, turning it counter-clockwise. Remove the entire knob and lead screw from the pump.

NOTE

Do not change the pump capacity setting (0%) (i.e. move the crank (281-A)) during this procedure.

5. If the percent capacity plate (aluminum decal) (253-C) is in good condition, you will not need to change it. If it needs to be changed, use a pocket knife to remove the percent capacity plate from the rear hub extension of the pump housing. Press on a new one in the exact location of the old decal.
6. Using a small propane torch, heat the three mounting hole plugs. These plugs are held in place with Loctite, and require heat to remove them in one piece. After removing the three plugs, degrease the mounting holes.

B.2.3 Installation

1. Apply 222 Loctite to the three mounting studs (40, Figure 20), and install them in place of the mounting hole plugs.
2. Install lead screw (60) with seal (70) in place. Turn screw into pump until the groove or slot in the end of the shaft lines up with the keys (211-A, Figures 9 and 10, 3390007000). Set keys in place and tighten set screws (405-AL). Loosen the shaft 1/8 turn. The new shaft will now be at zero setting.
3. Place the mounting bracket (350, Figure 20) over the studs and secure in place with 3/8 lockwashers (351) and 3/8 nuts (352).
4. Place the calibration ring (360) loosely over the end of the indicator knob (370) with the graduations toward the pump. Slide the indicator knob over the end of the lead screw and align

the holes in the indicator knob with the holes in the lead screw.

5. Apply a generous coat of light grease to the entire inside diameter of the coupling (380).
6. Slide the coupling over the indicator knob with a twisting motion and align the holes with the holes in the indicator knob.
7. Locate the bearing pin (390) and put an E-Ring (450) on one end.
8. Slide the bearing pin through the hole in the coupling, indicator knob and lead screw until it bottoms out on the E-Ring.
9. Put an E-Ring on the other end of the bearing.
10. Slide the calibration ring toward the pump and put a few drops of RTV on it. Slide the calibration ring back onto the indicator knob with zero facing straight up.
11. Locate the ECC (420) and drive collar (410).
12. Slide the drive collar onto the ECC shaft and align the holes in the drive collar with the holes in the ECC shaft so that the dowel pin (430) can be installed.
13. Install the dowel pin and tap flush.
14. Locate the bearing pin (390) and put an E-Ring on one end. Slide the bearing pin on until it bottoms against the E-Ring.
15. Install E-Ring to the other end to secure bearing pin in place.
16. Unscrew the ECC's cover.

CAUTION

IMPROPER CONNECTION OF THE POWER LINE OR INCORRECT SUPPLY VOLTAGE CAN CAUSE DAMAGE TO THE ECC. DISCONNECT ALL POWER BEFORE CONNECTING WIRES.

17. Connect electrical connections, Paragraph 2.6.

WARNING

YOU WILL BE MAKING ADJUSTMENTS TO THE ECC CONTROL CIRCUIT BOARD WHILE IT IS POWERED UP. THIS CONTROL BOARD IS POWERED BY POTENTIALLY DANGEROUS VOLTAGE (115 OR 230 V AC). THE CALIBRATION PROCEDURE IS TO BE PERFORMED ONLY BY QUALIFIED PERSONNEL FAMILIAR WITH THE HAZARDS INHERENT WORKING NEAR HIGH VOLTAGES. MILTON ROY ASSUMES NO RESPONSIBILITIES FOR DAMAGE TO EQUIPMENT OR INJURY TO PERSONNEL WHILE PERFORMING THIS CALIBRATION PROCEDURE.

18. Perform calibration B, Paragraph 4.8.1.2.

APPENDIX C

C.1 MILROYAL C PUMP FIELD INSTALLATION (RETROFIT)

The Milroyal C electronic capacity control is available in kit form for field retrofit to an existing Milroyal C with manual stroke adjustment. The Milroyal C ECC retrofit kit consists of:

- ECC & worm gear speed reducer assy
- Lead screw with splined shaft
- Adapter
- Hardware and mounting screws

NOTE

The ECC gearbox requires approximately 1 pint (1/2 liter) AGMA-5 EP gear oil. Oil is added to the ECC gearbox by the manufacturer before it is shipped.

WARNING

THIS PROCEDURE INVOLVES DISASSEMBLY INSIDE THE MILROYAL C DRIVE. BEFORE PROCEEDING, DISCONNECT POWER TO THE PUMP MOTOR. LOCK AND TAG THE SWITCH.

Refer to Figure 21 in this manual, and to parts drawings in Milroyal C instruction manual 3390009000 for this procedure.

1. Carefully clamp the ECC in a vise or hold upright. Remove cover and apply power as described in the installation Section 2 and allow the unit to run until it reaches its lower limit (0% capacity position, red low limit light on). Disconnect power and replace cover.
2. Drain oil from pump gear chamber by removing drain plug.
3. Using micrometer knob, adjust pump capacity to 0%.
4. Rotate the pump motor shaft by hand to gain access to the lower part of the gear housing (200, 3390009000). Locate the two holes in the face of the gear housing. Inside each of these holes is a set screw (300).
5. Loosen each set screw approximately 3-1/2 turns and slide the two keys (290) aside. This will free the lead screw shaft (102) for removal.
6. Unscrew the handknob. The entire lead screw shaft will come out the rear of the pump.
7. Using pocket knife and pliers, remove the 0-100% plate (95) from the rear hub.
8. Set parts in step 7 aside, as they will not be used again.
9. Take the new lead screw shaft (102, Figure 21) which comes with the spline shaft connected to it and screw it into the pump so that it lines up with the two keys (290, 3390009000).
10. Slide the keys back into place.
11. Tighten the two set screws (300), then back off 1/8 turn from tight.
12. Slide aluminum mounting adapter (611, Figure 21) over rear hub of pump and loosely tighten the two set screws.
13. Apply grease to the splined portion of the lead screw (102). Carefully slide the ECC gearbox onto the splined shaft and bolt it to the adapter using the lockwashers and screws provided. Make sure the ECC is in a vertical position and tighten the two set screws on the adapter to secure the assembly to the pump. Loctite is recommended on these set screws.
14. Apply the 0-100% label to the indicator tube (693) Slip the tube onto the lead screw shaft protruding from the gearbox. Do not tighten.
15. Align the indicator tube "0%" mark with the "0" on the indicator ring and tighten the set screws on both. This setting can be adjusted after going through the ECC calibration B check in Section 4, "Maintenance" to exactly set pump zero and 100% locations.
16. Refill the pump drive gearbox with oil.
17. Perform the ECC initial start-up procedure, Section 3, and re-calibrate Section 4 if required.