



Bulletin B-308F

# Bell & Gossett



## Series 1535 Close Coupled Centrifugal Pumps

A close coupled industrial pump designed for heavy duty requirements in cooling tower, refrigeration, industrial and general service applications.

- 225°F maximum working temperature
- 175 psi maximum working pressure
- 100% factory tested
- Low maintenance, rugged construction
- Broad range of sizes, horizontal or vertical installation

**motralec**

4 rue Lavoisier . ZA Lavoisier . 95223 HERBLAY CEDEX  
Tel. : 01.39.97.65.10 / Fax. : 01.39.97.68.48  
Demande de prix / e-mail : [service-commercial@motralec.com](mailto:service-commercial@motralec.com)  
[www.motralec.com](http://www.motralec.com)

Bell & Gossett

 **ITT Industries**  
*Engineered for life*

# SERIES 1535 PUMPS A STEP ABOVE OTHER GENERAL PURPOSE PUMPS

## 1. RUGGED CONSTRUCTION

The Series 1535 is a rugged industrial pump boasting a heavy cast iron volute and bracket, and a brass impeller. It is rated for 175 PSI maximum working pressure, far greater than many competitive units. Suction and discharge gauge tapings are standard.

## 2. RELIABLE MOTOR

This is a continuous duty industrial motor, higher quality than the usual jet-pump style motor. Since the heavy duty ball bearings are lubricated for life, the motor requires no maintenance.

## 3. HIGH QUALITY SEAL

The time proven Bell & Gossett carbon-ceramic mechanical seal is standard on this pump. This special self flushing design is further assurance that the Series 1535 is a quality product.

## 4. EASY TO SERVICE

Just two sizes of seals and motor brackets covers the entire line of Series 1535 pumps, a plus in interchangeability. It simplifies stocking of critical replacement parts. The standard B&G back pullout feature allows for ease of maintenance without disturbing piping constructions.

## 5. QUICK DELIVERY

All sizes of Series 1535 pumps are available from stock from your nearby B&G representative.

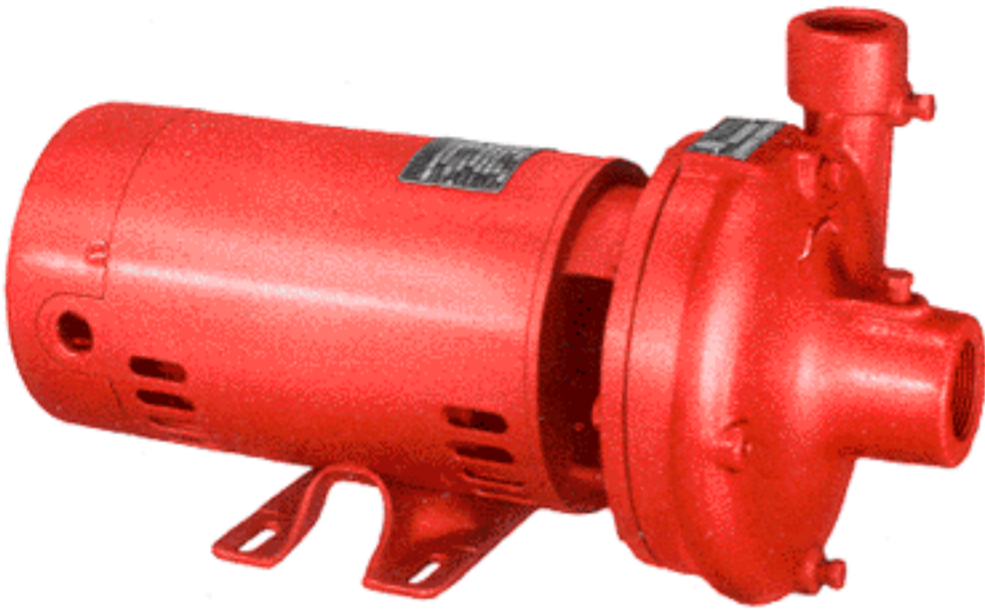

## SERIES 1535 CENTRIFUGAL PUMPS PERFORMANCE CURVES

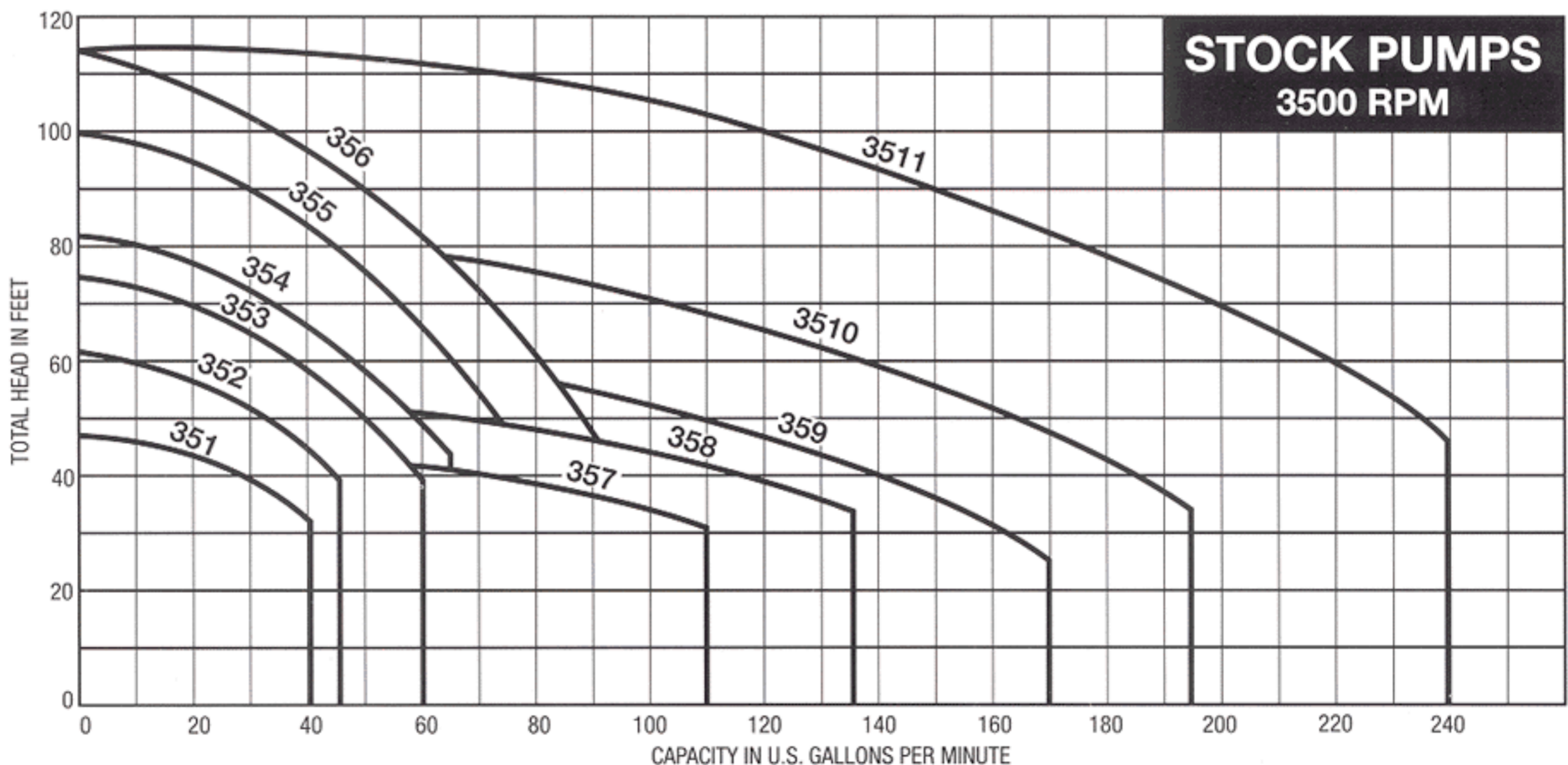

Add "S" to pump number when ordering single phase pumps. Add "T" to pump number when ordering three phase pumps.

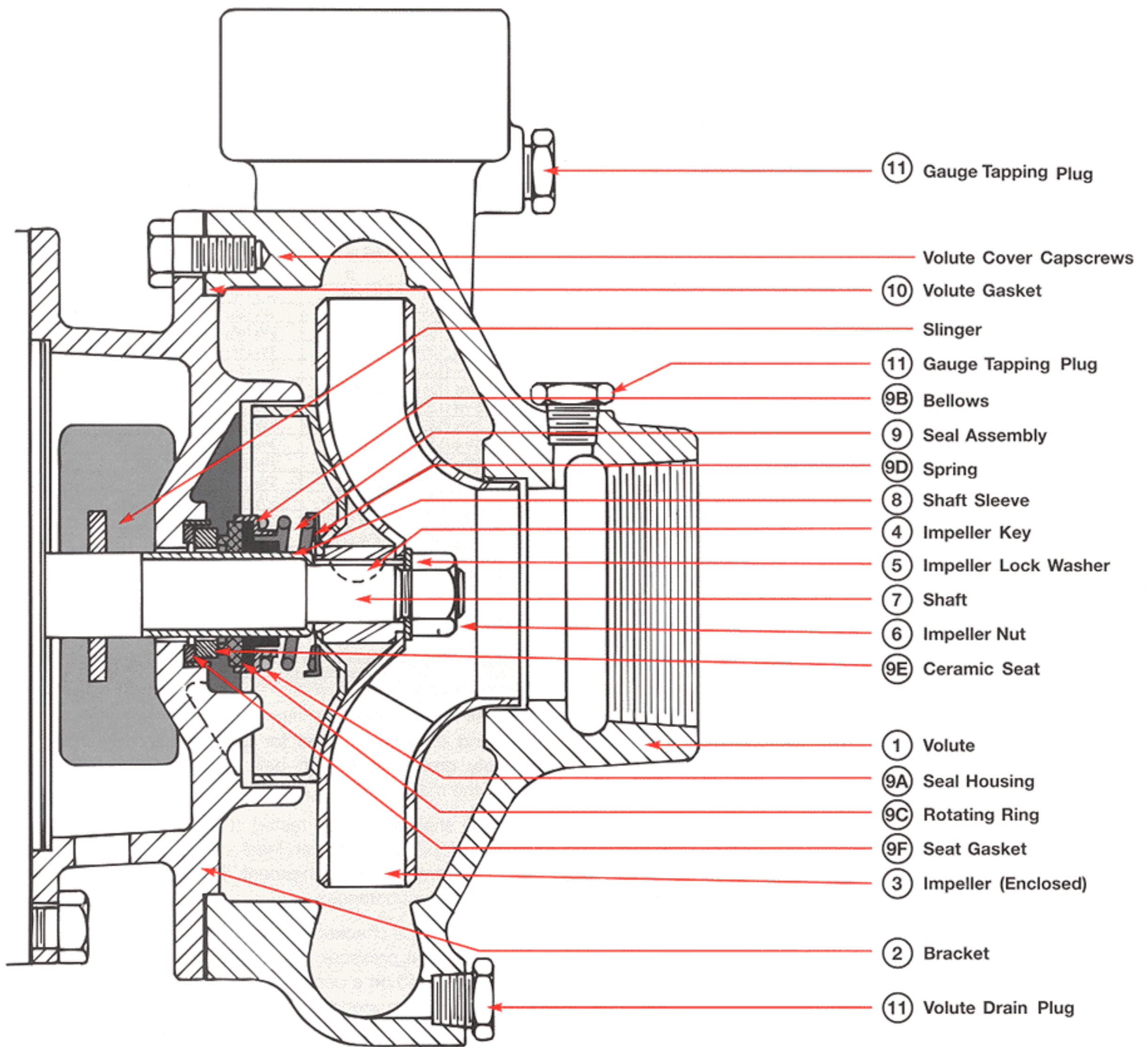

1. Volute . . . . . Cast Iron ASTM #A159	9. Seal Assembly	
2. Bracket . . . . . Cast Iron ASTM #A159	A. Seal Housing . . . . . Brass-ASTM #B36	
3. Impeller . . . . . Brass ASTM #B36	B. Bellows . . . . . Buna "N"	
4. Impeller Key . . . . . #316 Stainless Steel	C. Rotating Ring . . . . . Carbon	
5. Impeller Lock Washer . . . . . #316 Stainless Steel	D. Spring . . . . . Stainless Steel	
6. Impeller Nut . . . . . #316 Stainless Steel	E. Seat . . . . . Ceramic	
7. Shaft . . . . . Carbon Steel	F. Seat Gasket . . . . . Buna "N"	
8. Shaft Sleeve . . . . . Copper Alloy 110	10. Volute Gasket . . . . . Cellulose Fiber	
	11. Plugs . . . . . Carbon Steel	

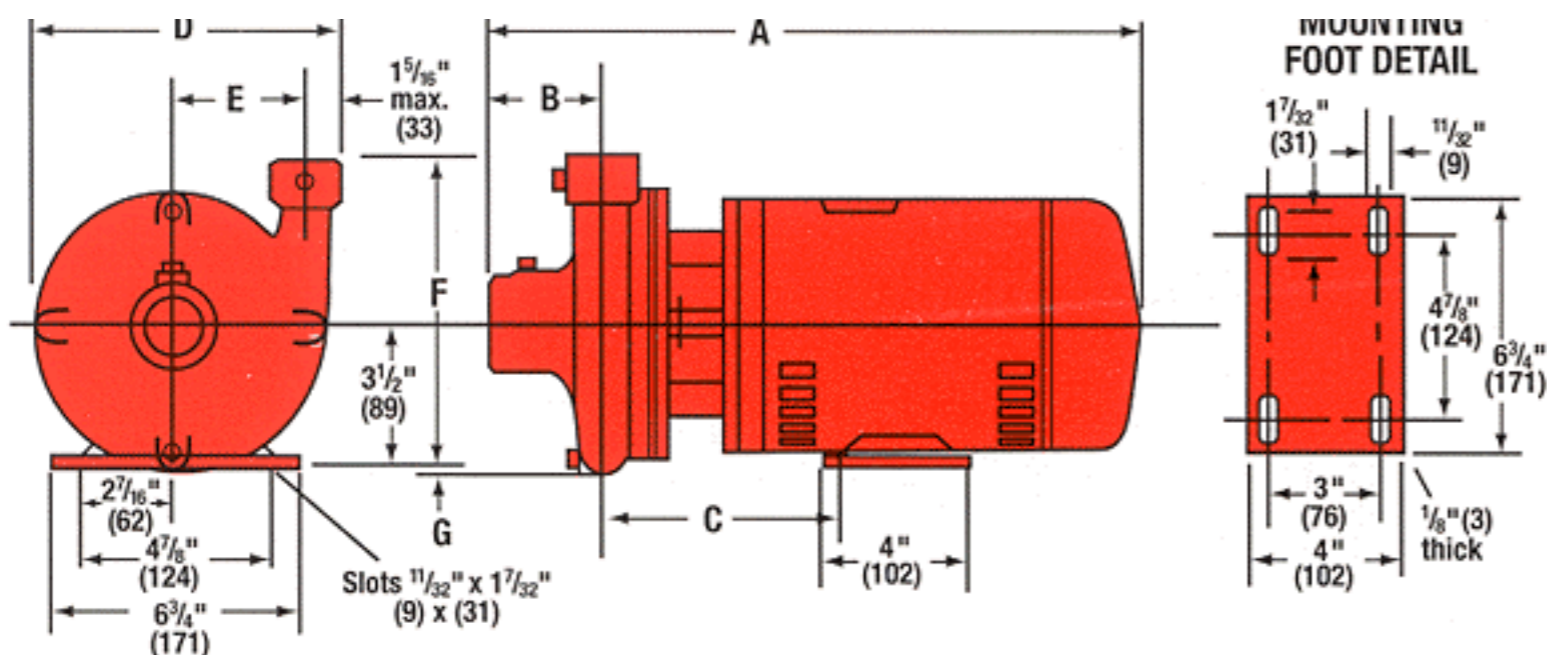

Bronze fitted Construction. Motors – Open Dripproof. Single Phase – Unit Number ending in "S", 115/230 Volt, 60 Cycle, 1 Phase. Three Phase – Unit Number ending in "T", 208-230/460, 60 Cycle, 3 Phase. All Single Phase Motors have built in overload protectors. **3500 RPM 175 PSI (12 bar) Maximum Working Pressure** Add "S" to pump number when ordering single phase pumps. Add "T" to pump number when ordering three phase pumps.

MODEL NO.	H.P.	SUCTION SIZE	DISCHARGE SIZE	DIMENSIONS IN INCHES (MM)						
				A	B	C	D	E	F	G
351S	1/3	1 1/4	1	15 (381)	2 15/16 (75)	5 5/16 (135)	8 (203)	3 3/8 (86)	8 (203)	1/4 (6)
351T	1/3	1 1/4	1	15 (381)	2 15/16 (75)	5 5/16 (135)	8 (203)	3 3/8 (86)	8 (203)	1/4 (6)
352S	1/2	1 1/4	1	15 (381)	2 15/16 (75)	5 5/16 (135)	8 (203)	3 3/8 (86)	8 (203)	1/4 (6)
352T	1/2	1 1/4	1	15 (381)	2 15/16 (75)	5 5/16 (135)	8 (203)	3 3/8 (86)	8 (203)	1/4 (6)
353S	3/4	1 1/4	1	15 1/2 (394)	2 15/16 (75)	5 5/16 (135)	8 (203)	3 3/8 (86)	8 (203)	1/4 (6)
353T	3/4	1 1/4	1	15 1/2 (394)	2 15/16 (75)	5 5/16 (135)	8 (203)	3 3/8 (86)	8 (203)	1/4 (6)
354S	1	1 1/4	1	16 (406)	2 15/16 (75)	5 5/16 (135)	8 (203)	3 3/8 (86)	8 (203)	1/4 (6)
354T	1	1 1/4	1	16 (406)	2 15/16 (75)	5 5/16 (135)	8 (203)	3 3/8 (86)	8 (203)	1/4 (6)
355S	1 1/2	1 1/4	1	16 15/16 (430)	2 15/16 (75)	5 5/16 (135)	8 (203)	3 3/8 (86)	8 (203)	1/4 (6)
355T	1 1/2	1 1/4	1	16 7/16 (418)	2 15/16 (75)	5 5/16 (135)	8 (203)	3 3/8 (86)	8 (203)	1/4 (6)
356T	2	1 1/4	1	16 7/16 (418)	2 15/16 (75)	5 5/16 (135)	8 (203)	3 3/8 (86)	8 (203)	1/4 (6)
357S	1	2	1 1/2	16 1/4 (413)	2 15/16 (75)	5 9/16 (141)	8 3/8 (213)	3 3/8 (86)	8 3/4 (222)	1/2 (13)
357T	1	2	1 1/2	16 1/4 (413)	2 15/16 (75)	5 9/16 (141)	8 3/8 (213)	3 3/8 (86)	8 3/4 (222)	1/2 (13)
358S	1 1/2	2	1 1/2	17 3/16 (437)	2 15/16 (75)	5 9/16 (141)	8 3/8 (213)	3 3/8 (86)	8 3/4 (222)	1/2 (13)
358T	1 1/2	2	1 1/2	16 11/16 (424)	2 15/16 (75)	5 9/16 (141)	8 3/8 (213)	3 3/8 (86)	8 3/4 (222)	1/2 (13)
359T	2	2	1 1/2	16 11/16 (424)	2 15/16 (75)	5 9/16 (141)	8 3/8 (213)	3 3/8 (86)	8 3/4 (222)	1/2 (13)
3510T	3	2	1 1/2	17 3/16 (437)	2 15/16 (75)	5 9/16 (141)	8 3/8 (213)	3 3/8 (86)	8 3/4 (222)	1/2 (13)
3511T	5	2	1 1/2	18 11/16 (475)	2 15/16 (75)	5 9/16 (141)	8 3/8 (213)	3 3/8 (86)	8 3/4 (222)	1/2 (13)

2 HP through 5 HP units are not available in single phase.

## TYPICAL SPECIFICATIONS

Furnish and install pumps with capacities as shown on plans. Pumps shall be close coupled, single-stage, vertically-split case design, capable of being serviced without disturbing piping connections.

Pump volute shall be Class 30 cast iron, and impeller shall be brass enclosed type, keyed to the shaft and secured by a lock washer and nut.

The liquid cavity shall be sealed off at the motor shaft by an internally-flushed mechanical seal with ceramic seal seat of at least 99% alumina oxide content, and carbon seal ring, suitable for continuous operation at 225° F. A replaceable shaft sleeve of copper alloy shall completely cover the wetted area under the seal.

Pumps shall be rated for minimum of 175 psi working pressure. Casings shall have gauge ports, and vent and drain ports at top and bottom of casing.

Motor shall meet NEMA specifications and shall be of the size, voltage and enclosure called for on the plans. It shall have heavy-duty grease lubricated ball bearings, completely adequate for the maximum load for which the motor is designed.

Each pump shall be factory tested. It shall then be thoroughly cleaned and painted with at least one coat of high grade machinery enamel prior to shipment. The paint shall be free of ozone depleting substances.

Each pump shall be checked by the contractor and regulated for proper differential pressure, voltage and amperage draw. This data shall be noted on a permanent tag or label and fastened to pump for owner's reference.

Pumps shall be Series 1535 as manufactured by ITT Bell & Gossett.

**motralec**

4 rue Lavoisier . ZA Lavoisier . 95223 HERBLAY CEDEX  
Tel. : 01.39.97.65.10 / Fax. : 01.39.97.68.48

Demande de prix / e-mail : [service-commercial@motralec.com](mailto:service-commercial@motralec.com)

[www.motralec.com](http://www.motralec.com)

 ITT Industries

**Bell & Gossett**

**USA**  
Bell & Gossett  
8200 N. Austin Avenue  
Morton Grove, IL 60053  
Phone: (847) 966-3700  
Facsimile: (847) 966-9052  
<http://www.bellgossett.com>



**INTL.**  
Bell & Gossett / Export Dept.  
8200 N. Austin Avenue  
Morton Grove, IL 60053  
Phone: (847) 966-3700  
Facsimile: (847) 966-8366  
Cable: BELGOSSETT

**CANADA**  
Fluid Products Canada  
55 Royal Road  
Guelph, Ontario,  
N1H 1T1, Canada  
Phone: (519) 821-1900

© COPYRIGHT 1970, 1999 BY ITT INDUSTRIES, INC.  
PRINTED IN U.S.A. 6-99