

C 9000  
C 11000  
C 13500

## Catalogo Tecnico

Technical catalogue

Catalogue technique

Technischer Katalog

Catálogo Técnico

Catálogo Técnico



**Battioni®  
Pagani  
Pompe**

**motralec**

4 rue Lavoisier . ZA Lavoisier . 95223 HERBLAY CEDEX  
Tel. : 01.39.97.65.10 / Fax. : 01.39.97.68.48  
Demande de prix / e-mail : [service-commercial@motralec.com](mailto:service-commercial@motralec.com)

[www.motralec.com](http://www.motralec.com)

**Battioni Pagani Pompe®** in cooperation with SPRInT, the Team of Engineering and Research of the Department of Industrial Engineering at the University of Parma, are proud to present the new **MEC II** pump: a technology breakthrough result of a major joint effort in product development and of innovative design processes. The MEC II offers world class top performances and increased structural resistance achieved despite reduced weight and size compared with its predecessor and any other similar product available on the market.

A first time ever in agricultural pump industry, our scientific method and rigorous approach to product design combining advanced engineering processes and virtual simulations, have been instrumental to further improve the performances of our products combining the right mix of technology innovation with our traditional long standing values of quality and reliability.

**Battioni Pagani Pompe®** is a world wide leader in design and manufacturing of Rotary Vanes Vacuum Pumps for agricultural and industrial markets since 1952. With a production capacity of over 20.000 pumps the company further widens its product portfolio by adding the MEC II pump to the MEC family. **Battioni Pagani Pompe®** is a ISO 9001 certified company and with more than 500.000 MEC pumps delivered to over 100 countries **Battioni Pagani Pompe®** is recognized for its proven track record of consistent delivery of quality and reliability to its customers worldwide.



**NEW IDEA**

Our Partners....

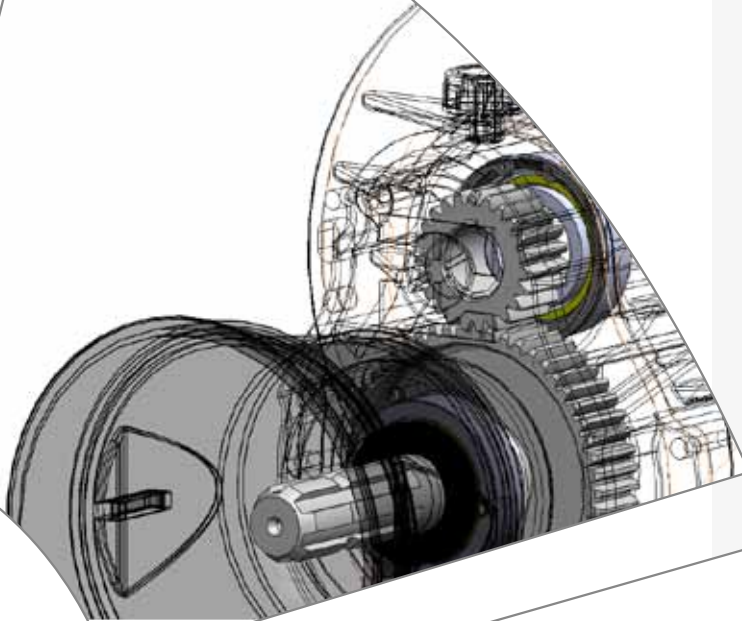

**SPRInT** is a Team of Engineering and Research in Mechanical Design and Construction Machinery area at the Department of Industrial Engineering at the University of Parma, mixing strong Research and Industrial Development Experiences and Technical-Scientific Research.



**SPRInT** cooperates with industrial companies concerning Research and Development, Engineering, Advice and Training in Structural Mechanical Design, CAD/CAE Methods, Virtual Prototyping sectors.

The experience reached and quality of realized projects allow to collaborate with industrial companies on their product innovation process in full compliance with their requirements.

home: [www.sprint-solutions.it](http://www.sprint-solutions.it)  
mail: [info@sprint-solutions.it](mailto:info@sprint-solutions.it)

**CREATIVE DESIGN**

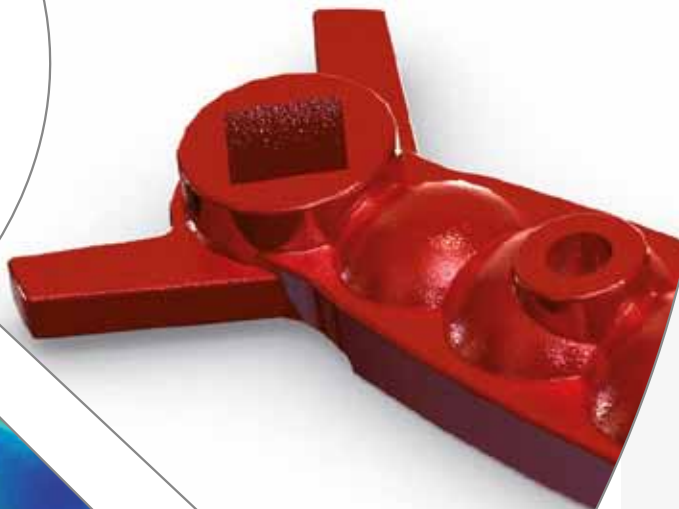

**e-FEM** is an Engineering Company specialized (qualified) in CAE (Computer Aided Engineering) area and it is born after natural maturation of technical-scientific and professional experiences of its members, mixing high level engineering knowledge and well-established (strong) experience in CAE desing sectors. Multidisciplinarity, professionalism and high dynamism are the features that allow to **e-FEM** to assist and support customers, through a complete offer of simulation and design services, in their decision-making process for the product innovation and development. **e-FEM** are qualified in following areas: 3D-model, structural and mechanical design, FEM calculation, multibody dynamic analysis, fluid-dynamic analysis, structural optimization, advanced (innovative) composite materials and polymeric materials.

home: [www.e-fem.it](http://www.e-fem.it)  
mail: [info@e-fem.it](mailto:info@e-fem.it)

**SIMULATION**

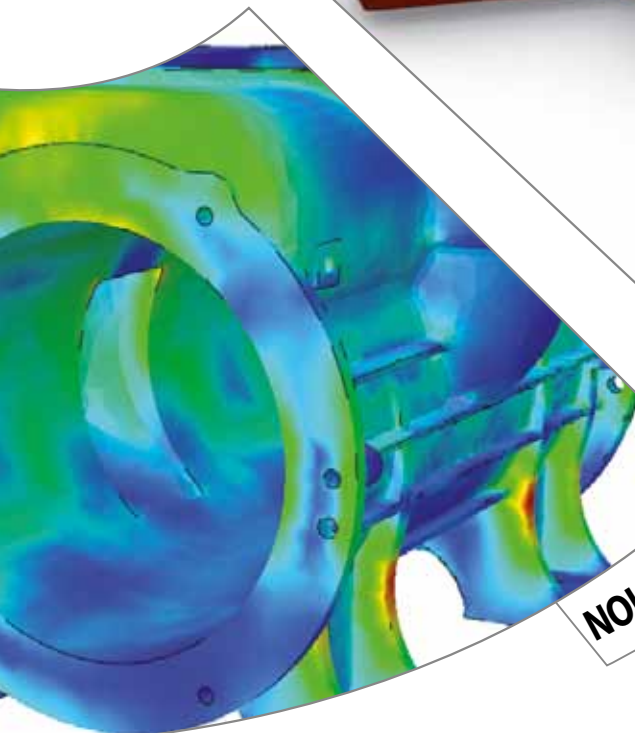

**FUORITHEMA ARCHITETTURA**  
Located in Parma, is made of professionals with proved experience. They are organized, together with external consultants, in a multidisciplinary team able to issue the more suitable proposal for every situation in the field of industrial and handicrafts design, architecture and design.

**FUORITHEMA**  
Architettura

home: [www.fuorithema.com](http://www.fuorithema.com)  
mail: [info@fuorithema.com](mailto:info@fuorithema.com)

## ENGINEERING AND MANUFACTURING

Our design methodology and state of the art mass production equipment and processes assure to all our customers consistent delivery of product performance, quality and reliability at the lowest possible cost.

## FINITE ELEMENT METHOD ANALYSIS (FEM)

The MEC II is designed by Finite Element Method to achieve very compact dimensions and light weight. This has been obtained at no compromise with performances: for example the structural shock resistance of the pump in case of blades crash is instead considerably increased.

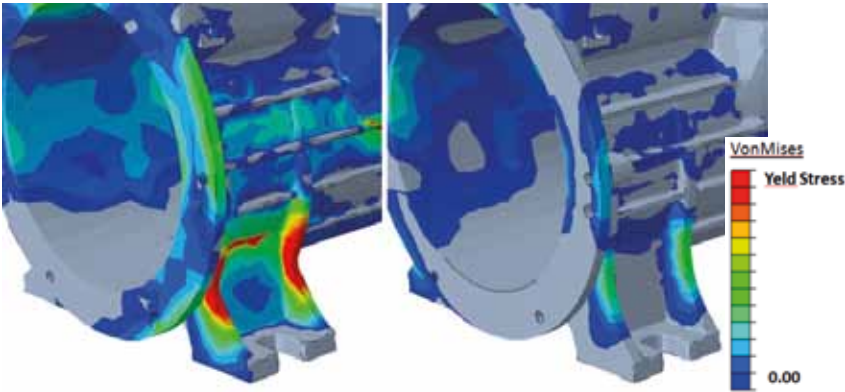
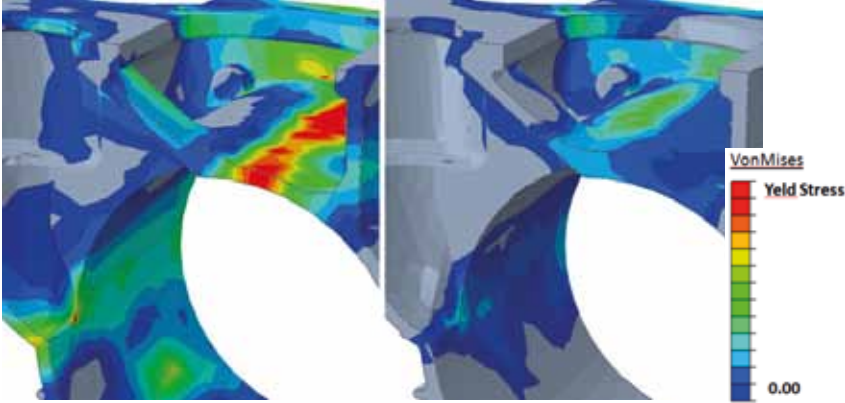

## CRASH PROTECTION SYSTEM

The MEC II *Sliding Flanges* protection mechanism prevents the housing or rotor to break of in case of vanes crash.

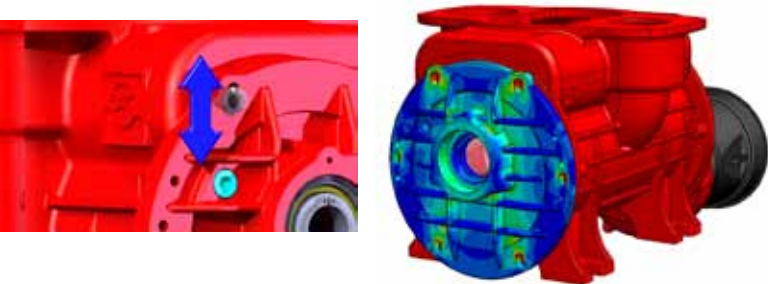

## AXIAL COOLING FINS

The accurate dimensioning of the housin cooling fins maximizes the quantity of heat dissipated by natural convection under any working conditions.

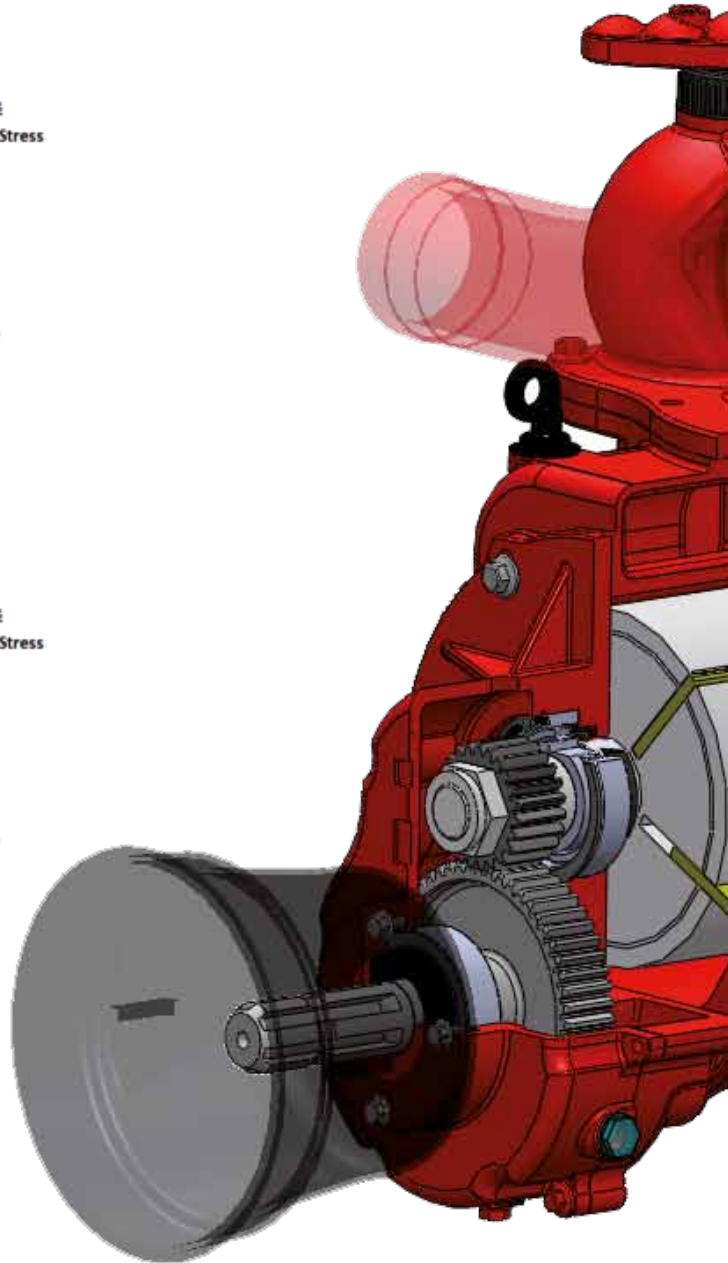

### COMPUTATIONAL FLUID DYNAMIC (CFD)

The Computational Fluid Dynamic analyzes in details the behavior of air flows and pressures within the vacuum lines. Streamlining ducts is mandatory to obtain maximum efficiency and to eliminate overheating at the most extreme working conditions.

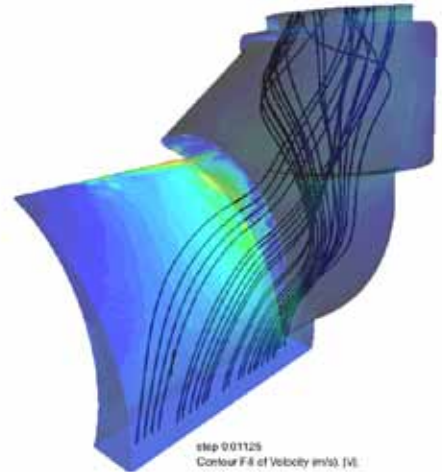

### THERMOGRAPHIC TEST

The thermo-graphic analysis of the temperature gradient and of the distribution of the infrared radiations points exactly to the areas where efficiency improvements maybe required.

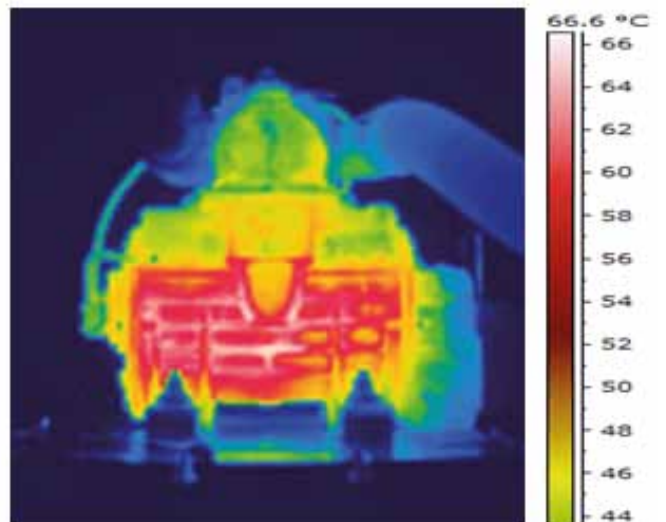

### PUMP ACCEPTANCE TEST

Conformity and CE certificates are released subsequent to final assembly at the end of the manufacturing line where our automatic computer station tests compliancy of each pump performances maintaining a serial number database for full traceability.

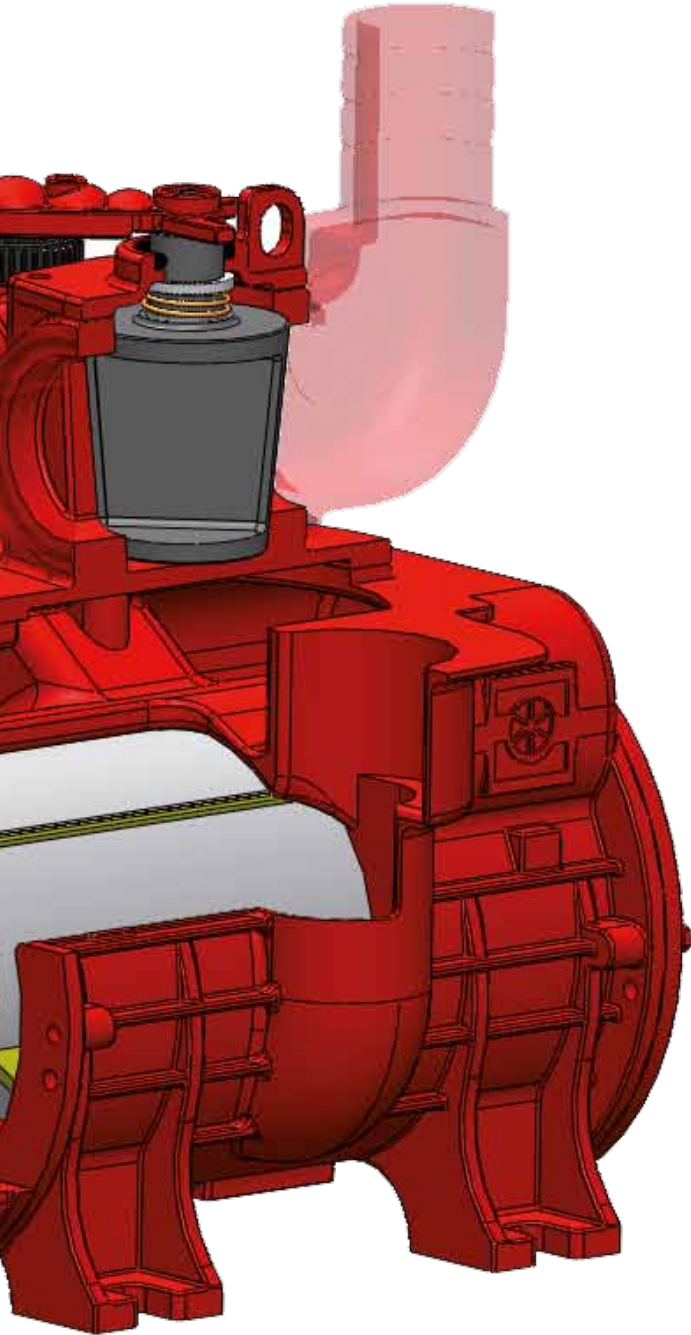

# MEC

## 9000 - 11000 - 13500

### Non-return check valve as standard

Valvola di non ritorno di serie  
Soupape de contrôle de série  
Kontrollventil als Serie  
Válvula de retención de serie  
Válvula de retenção de série

### Temperature indicator

Rilevatore di temperatura  
Détecteur de température  
Temperaturdedektor  
Indicador de temperatura  
Indicador de temperatura

### 160° C Irreversible indicator

Indicatore Irreversibile 160° C  
Indicateur irréversible 160°C  
irreversibel Anzeiger 160°C  
Testigo irreversible de  
sobrecalentamiento a 160 °C  
Indicador irreversiblel 160°



### Force feed lubrication pump as standard (automatic lubrication on request)

Pompa di lubrificazione forzata di serie  
(lubrificazione automatica a richiesta)  
Pompe de lubrification forcée de série  
(pompe de lubrification automatique sur demande)  
Druckschmierung als Serie (Automatische  
Schmierung auf Anfrage)  
Bomba de lubricación forzada de serie  
(lubricación automática bajo pedido).  
Bomba de lubrificação forçada de série  
(lubrificação automática por encomenda)

### Heat-resistant blades of special material as series

Palette "long life" resistenti al calore di serie  
Palettes en matériel spécial résistant à la chaleur de série  
Hitzebeständigen Lamellen aus Spezialmaterial als Serie  
Paletas especiales, resistentes al calor y al desgaste de serie  
Paletes em material especial resistentes ao calor de série

### Long life blades

Optimized according to specifications given by Battioni Pagani Pompe. The special hot embossing of the company "logo" is a guarantee of proved and tested quality.

**Predisposition for overpressure valve**  
Predisposizione per valvola di sovrappressione  
Prédisposition pour soupape de surpression  
Vorbereitung für Überdruckventil  
Disposição para válvula de sobrepresao

**Predisposition for depression valve**  
Predisposizione per valvola di regolazione vuoto  
Prédisposition pour soupape de depression  
Vorbereitung für Überdruckventil nicht geeicht  
Disposição para válvula de controle vácuo

### High wearing resistance thanks to cast-iron with high hardness

Elevata resistenza ad usura grazie a ghisa ad alta durezza  
Resistance à l'usure élevée suivant à fonte avec dureté élevée  
Hohe Festigkeit zu Abnutzung für Gußeisen mit hohe Härte  
Elevada resistencia al desgaste debido a una fundición de alta dureza.  
Alta resistência contra o desgaste graças ao ferro fundido de elevada dureza

### Air injection cooling (BALLAST) on request

Iniezione aria di raffreddamento (BALLAST) a richiesta  
Injection air de refroidissement (BALLAST) sur demande  
Injektion der Luftkühlung (BALLAST) auf Anfrage  
Inyección de aire de refrigeración (BALLAST) bajo pedido  
Arrefecimento por injeção de ar (BALLAST) per incominda

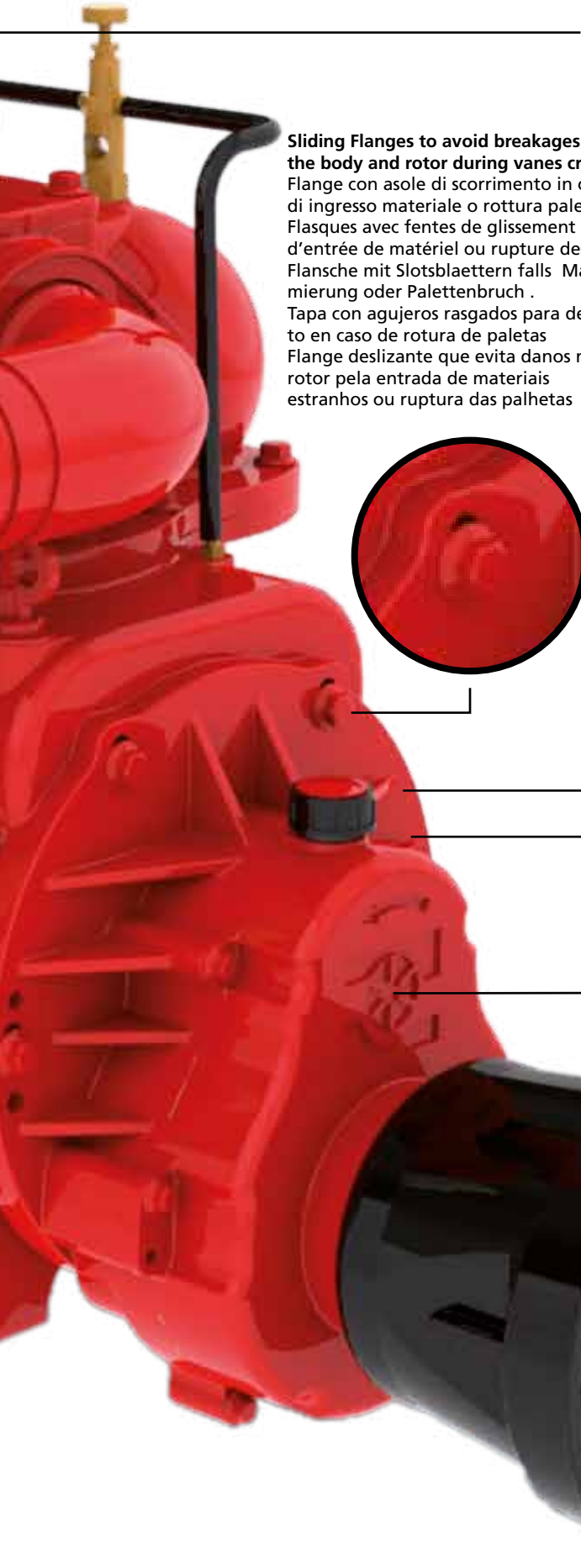

**Selector vacuum - pressure**  
 Selettore Vuoto - Pressione  
 Sélecteur vide-pression  
 Wähler von Vakuum/Druck  
 Selector vaclo - presión.  
 Selector Vácuo - Pressão

Selection handle for vacuum/compression  
 Ergonomic design and comfortable rotation thanks to the use of new solutions and materials with low friction coefficient.

**Sliding Flanges to avoid breakages of the body and rotor during vanes crashes**

Flange con asole di scorrimento in caso di ingresso materiale o rottura palette  
 Flashes avec fentes de glissement en cas d'entrée de matériel ou rupture des palettes  
 Flansche mit Slotsblättern falls Materialschmierung oder Palettenbruch .  
 Tapa con agujeros rasgados para deslizamiento en caso de rotura de paletas  
 Flange deslizante que evita danos no corpo e rotor pela entrada de materiais estranhos ou ruptura das palhetas



**Flange-housing alignment control**

Tacca di allineamento flangia - corpo  
 Cran de alignement flasque-corps  
 Ausrichtmarke der Flanschgehäuse  
 Muesca de alineacion tapa-cuerpo  
 Cran de alignement flasque-corps  
 Muesca de alineacion tapa-cuerpo  
 Controlo de alinhamento da flange-corpo



**Blades inspection hole**  
 Foro ispezione palette  
 Trou d'inspection palettes  
 Bohrung für Lamellen Prüfung  
 Agujero de inspección paletas.  
 Orifício inspeção de paletas

**Vaness inspection hole with max wearing indicator**  
 Tacca per rilevamento usura palette  
 Cran de relev usure des palettes  
 Ausrichtmarke für die Abnutzung der Palette  
 Señal para indicación de desgaste de paletas  
 Visor para inspeção e indicador de desgaste máximo das palhetas

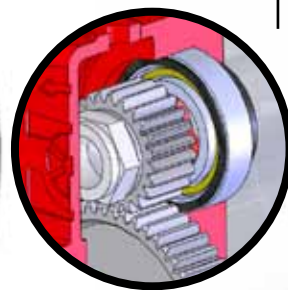
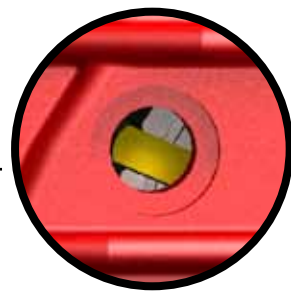

**Compression and thrust rings for bearings**  
 Anello di compensazione  
 Bague de compensation  
 Ausgleichsring  
 Anillo de compensación  
 Anilhas de compensação para rolamentos

Fitted in front and back side of the rotor, they allow to keep an axial centering even during heavy duty uses. They also contribute to reduce noise during pump running.

# MEC/M-MA

9000 - 11000 - 13500



The version / M has been projected to be driven by cardan shaft at 540 rpm or 1000 rpm (MA)

La versione / M è stata ideata per essere azionata tramite albero cardanico a 540 rpm o 1000 rpm (MA)

La version / M a été projetée pour être actionnée par un arbre à cardan 540 tpm o 1000 tpm (MA)

In der Version / M die Antriebswelle (Zapfwelle) wird über eine Kardanwelle zu 540 upm. oder 1000 upm betrieben (MA)

La version / M ha sido concebida para ser accionada por una transmisión cardan a 540 rpm o 1000 rpm según version (MA)

A versão / M foi projectada para funcionar com eixo de cardan a 540 rpm o 1000 rpm (MA)

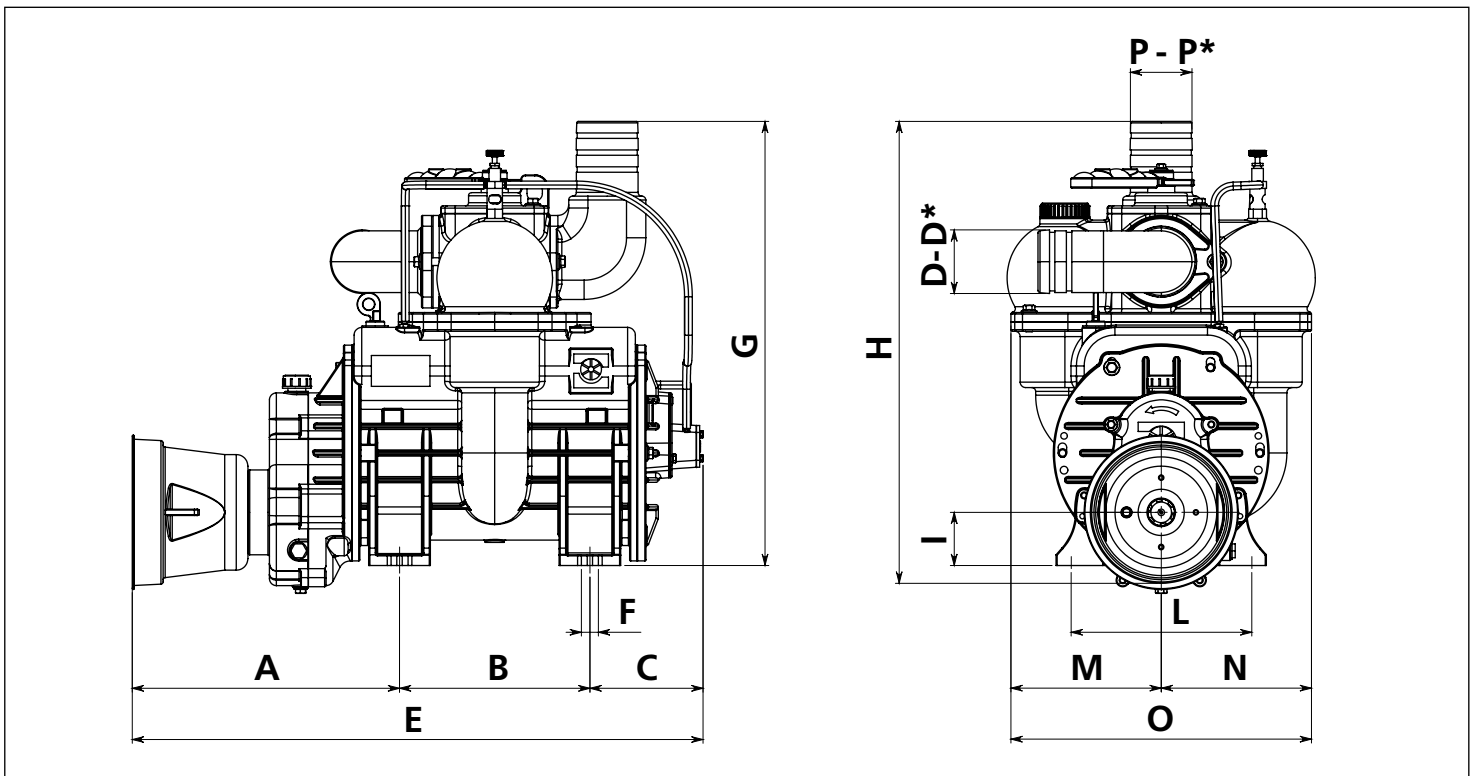

Article	A	B	C	D	D*	E	F	G	H	I	L	M	N	O	P	P*
MEC 9000 / M-MA	340	189	141	80	76-100	670	22	575	605	69	246	195	195	390	80	76-100
MEC 11000 / M-MA	346	247	147	100	76-80	740	22	575	605	69	246	195	195	390	100	76-80
MEC 13500 / M-MA	391	247	192	100	76-80	830	22	575	605	69	246	195	195	390	100	76-80

### MEC 9000 M

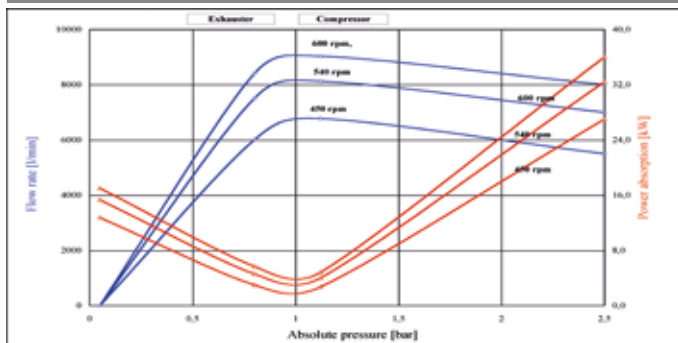

### MEC 9000 MA

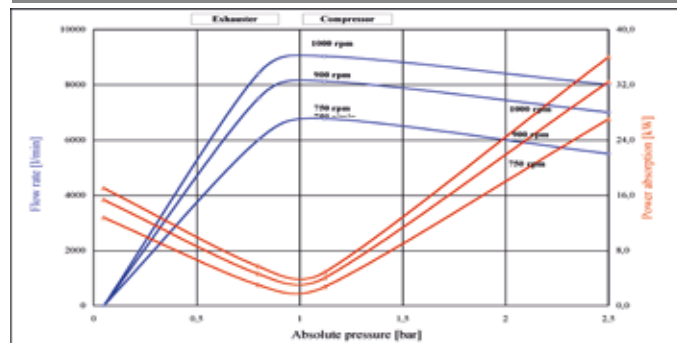

### MEC 11000 M

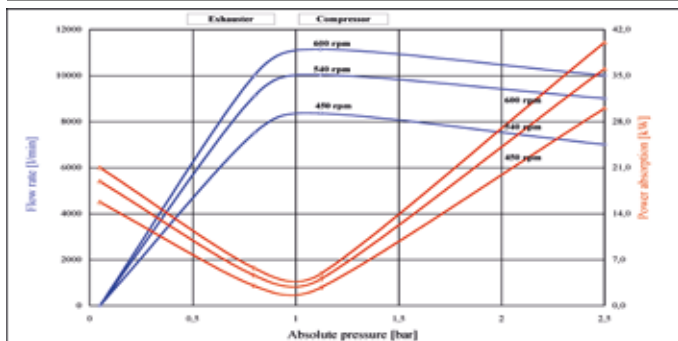

### MEC 11000 MA

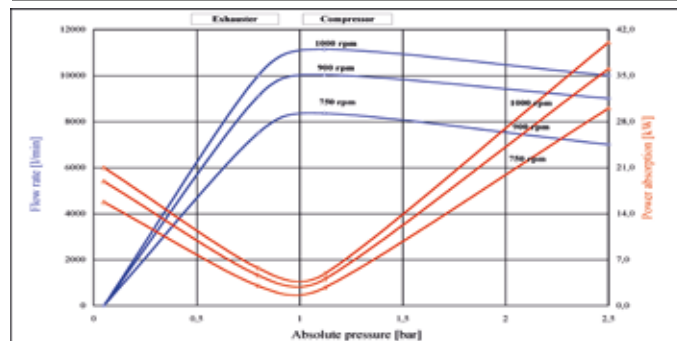

### MEC 13500 M

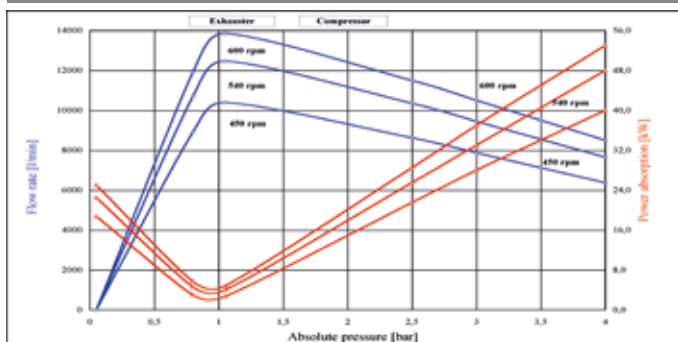

### MEC 13500 MA

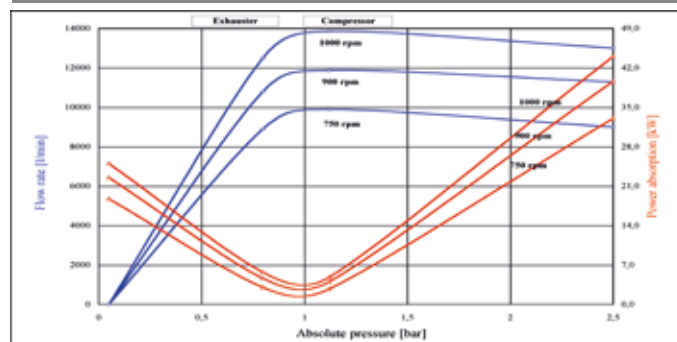

DATI TECNICI (technical data / données techniques / technische Daten / Datos tecnicos)		MEC 9000	MEC 11000	MEC 13500
Portata geometrica (Geometrical capacity / Débit géométrique / Geometrisch leistung / Caudal geométrico / Capacidade geométrica)	[l / min]	9.030	11.137	13.845
Regime di lavoro max / M (max rpm / tours maximum / max drehzahl / rpm max)	[rpm]	600	600	600
Regime di lavoro max / MA (max rpm / tours maximum / max drehzahl / rpm max)	[rpm]	1000	1000	1000
Pressione max Assoluta (Relativa) Max absolute(relative) pressure / pression max absolue (relative) / max absolut (relativ) druck / presión max absoluta (relativa)	[bar]	2.5 (1.5)	2.5 (1.5)	2.5 (1.5)
Depressione senza valvola regolazione vuoto installata (Vacuum without depression valve fitted / vide sans soupape de depression montee / vakuum ohne eingebaute unterdruckventil / depresión sin válvula de vacío incorporada)	[bar]	-0.95	-0.95	-0.95
Depressione con valvola regolazione vuoto installata (Vacuum with depression valve fitted / vide avec soupape de depression montee / vakuum mit eingebaute unterdruckventil / depresión con válvula de vacío incorporada)	[bar]	-0.80	-0.80	-0.80
Ass. potenza a vuoto max, 600 r.p.m. (power absorption per max vacuum, 600 rpm / absorption puissance pour vide maximum, 600 rpm / leistungsbeoarf bei max vakuum 600 rpm / potencia absorbida max vacío, 600 rpm)	[kW]	17	21	25
Ass. potenza a vuoto max, 1000 r.p.m. (power absorption per max vacuum, 1000 rpm / absorption puissance pour vide maximum, 1000 rpm / leistungsbeoarf bei max vakuum 1000 rpm / potencia absorbida max vacío, 1000 rpm)	[kW]	17	21	25
Ass. potenza a 2.5 bar assoluti, 600 r.p.m. (power absorption at 2.5 bar absolute, 600 rpm / absorption puissance a 2.5 bar absolute, 600 rpm / leistungsbeoarf zu 2.5 bar absolute, 600 rpm / potencia absorbida a 2.5 bar absoluta, 600 rpm)	[kW]	36	40	44
Ass. potenza a 2.5 bar assoluti, 1000 r.p.m. (power absorption at 2.5 bar absolute, 1000 rpm / absorption puissance a 2.5 bar absolute, 1000 rpm / leistungsbeoarf zu 2.5 bar absolute 1000 rpm / potencia absorbida a 2.5 bar absoluta, 1000 rpm)	[kW]	36	40	44
Peso netto (net weight / poids net / netto-gewicht / peso neto)	[Kg]	145	160	178

# MEC/P

9000 - 11000 - 13500

The version / P is driven by pulleys and belts, particularly for application on truck.

La versione / P è azionata tramite puleggia e cinghie, in particolare per applicazioni su camion.

La version / P est actionnée par poulies et courroies, en particulier pour application sur camion.

In der Version / P die Antriebswelle (Zapfwelle) wird über eine Riemenscheibe mit Riemen betrieben, besonders für Anwendungen auf Lkw.

La version / P ha sido concebida para ser accionada a través de polea, para aplicaciones sobre camión.

A versão / P é accionada por roldana e correias, especial para aplicações com camiões.



## CHIAVETTA 8x7x50 UNI 6604

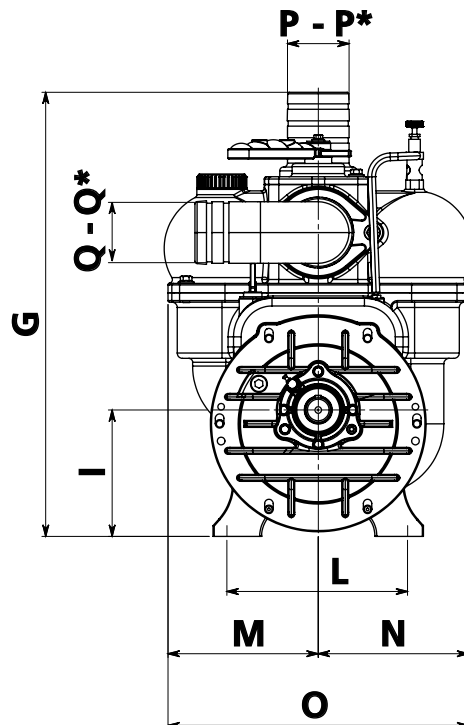
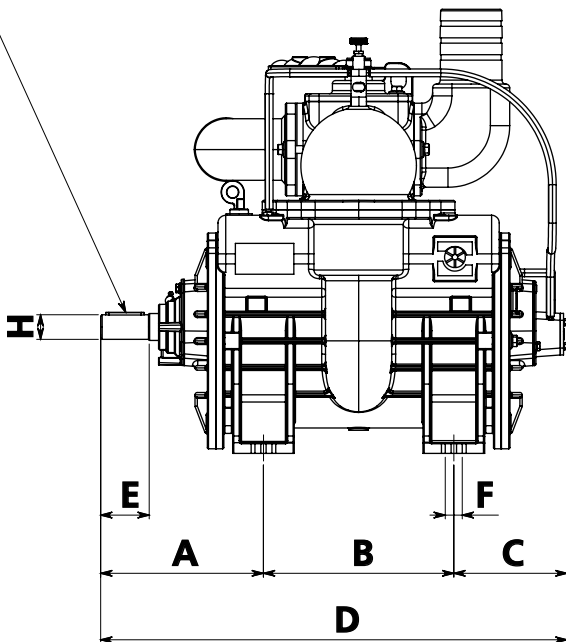

Article	A	B	C	D	E	F	G	H	I	L	M	N	O	P	P*	Q	Q*
MEC 9000 / P	205	189	141	535	63	22	575	32	164	246	195	195	390	80	76-100	80	76-100
MEC 11000 / P	211	247	147	605	63	22	575	32	164	246	195	195	390	100	76-80	100	76-80
MEC 13500 / P	256	247	192	695	63	22	575	32	164	246	195	195	390	100	76-80	100	76-80

## MEC 9000 P

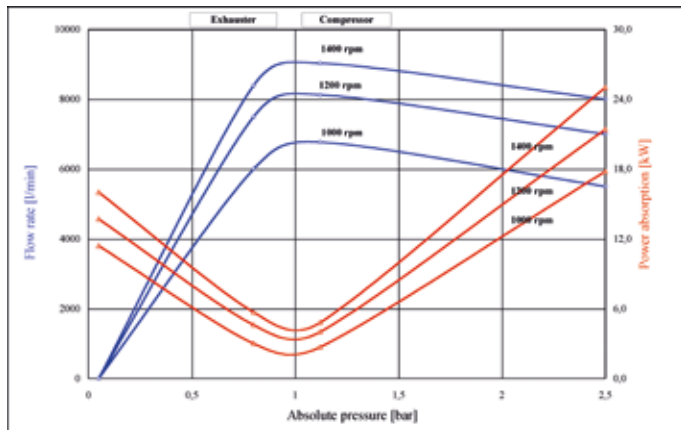

## MEC 11000 P

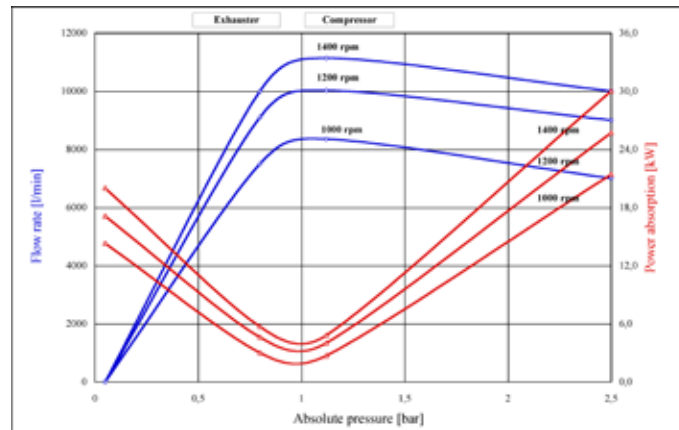

## MEC 13500 P

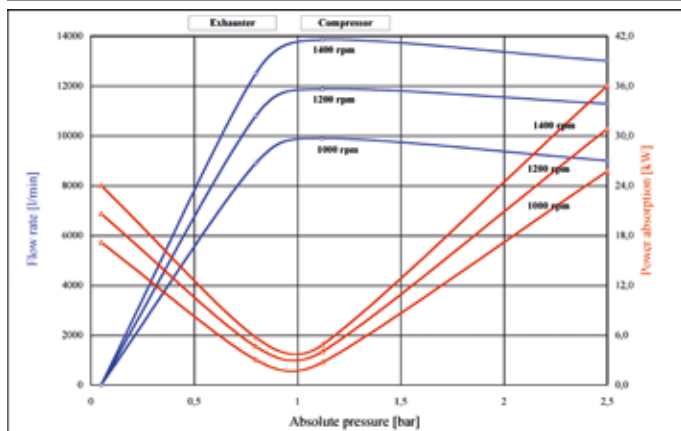

## PULLEY FOR BATTIONI PUMP

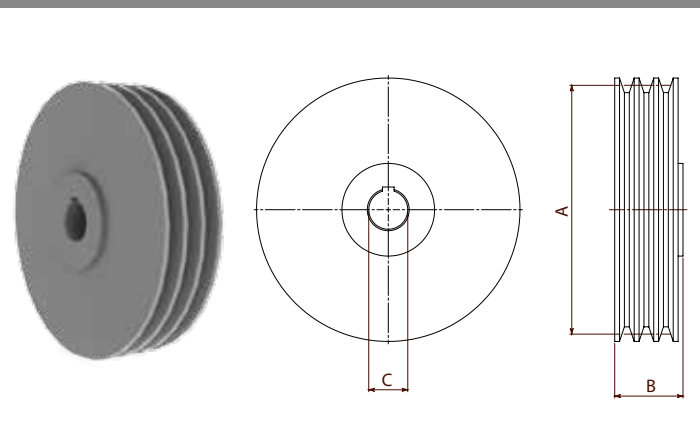

Code	Model	A	B	C	Type throat	Number throat	Kg	Article
4010001032	MEC 9/11/13500	Ø 300	90	Ø 32	SPC	3	25	2009/C

DATI TECNICI (technical data / données techniques / technische Daten / Datos tecnicos)		MEC 9000	MEC 11000	MEC 13500
Portata geometrica (Geometrical capacity / Débit géométrique / Geometrisch leistung / Caudal geométrico / Capacidade geométrico)	[l / min]	9.030	11.137	13.845
Regime di lavoro max / P (max rpm / tours maximum / max drehzahl / rpm max)	[rpm]	1400	1400	1400
Pressione max Assoluta (Relativa) Max absolute(relative) pressure / pression max absolue (relative) / max absolut (relativ) druck / presión max absoluta (relativa)	[bar]	2.5 (1.5)	2.5 (1.5)	2.5 (1.5)
Depressione senza valvola regolazione vuoto installata (Vacuum without depression valve fitted / vide sans soupape de depression montee / vakuum ohne eingebaute unterdruckventil / depresión sin válvula de vacío incorporada)	[bar]	-0.95	-0.95	-0.95
Depressione con valvola regolazione vuoto installata (Vacuum with depression valve fitted / vide avec soupape de depression montee / vakuum mit eingebaute unterdruckventil / depresión con válvula de vacío incorporada)	[bar]	-0.80	-0.80	-0.80
Ass. potenza a vuoto max, (power absorption per max vacuum / absorption puissance pour vide maximum / leistungsbedarf bei max vakuum / potencia absorbida max vacío)	[kW]	16	20	24
Ass. potenza a 2.5 bar assoluti, 1000 r.p.m. (power absorption at 2.5 bar absolute, 1000 rpm / absorption puissance a 2.5 bar absolute, 1000 rpm / leistungsbedarf zu 2.5 absolute 1000 rpm / potencia absorbida a 2.5 bar absoluta, 1000 rpm)	[kW]	25	30	36
Peso netto (net weight / poids net / netto-gewicht / peso neto)	[Kg]	131	146	164

# MEC/D

9000 - 11000 - 13500



The version / D has been projected to be driven by cardan shaft at 1000 rpm.

La versione / D è stata ideata per essere azionata tramite albero cardanico a 1000 rpm.

La version / D a été projetée pour être actionnée par un arbre à cardan 1000 tpm.

In der Version / D die Antriebswelle (Zapfwelle) wird über eine Kardanwelle zu 1000 upm. betrieben.

La version / D ha sido concebida para ser accionada a través una transmisión cardan a 1000 rpm

A versão / D foi projectada para funcionar com eixo de cardan a 1000 rpm.

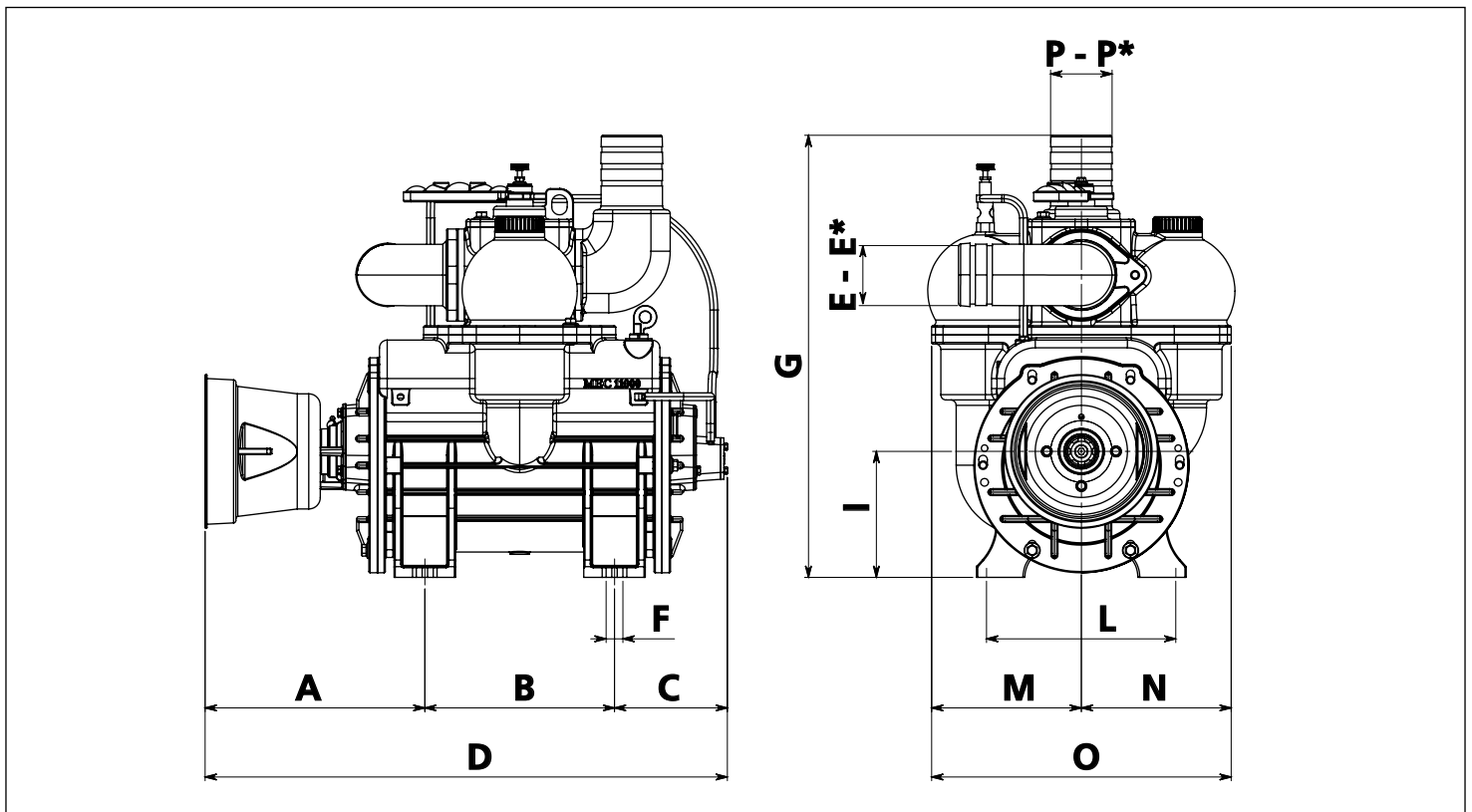

Article	A	B	C	D	E	E*	F	G	I	L	M	N	O	P	P*
MEC 9000 / D	280	189	141	610	80	76-100	22	575	164	246	195	195	390	80	76-100
MEC 11000 / D	286	247	147	680	100	76-80	22	575	164	246	195	195	390	100	76-80
MEC 13500 / D	331	247	192	770	100	76-80	22	575	164	246	195	195	390	100	76-80

## MEC 9000 D

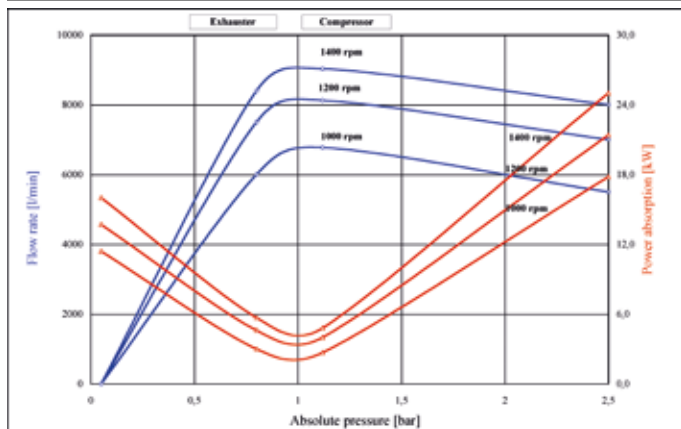

## MEC 11000 D

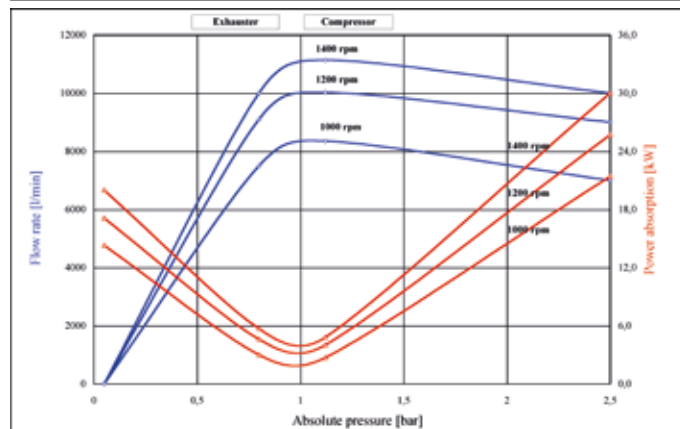

## MEC 13500 D

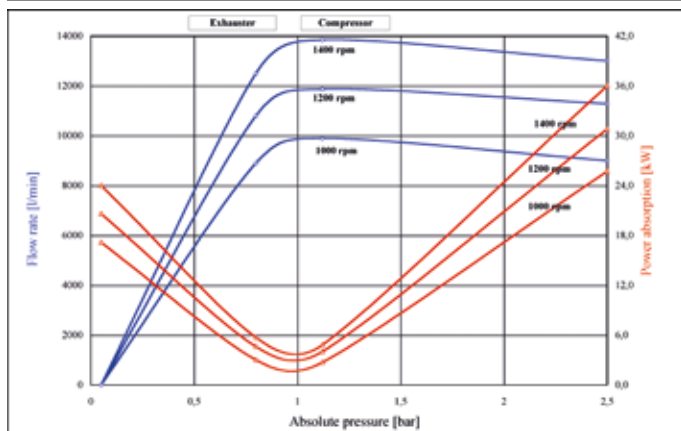

DATI TECNICI (technical data / données techniques / technische Daten / Datos tecnicos)		MEC 9000	MEC 11000	MEC 13500
Portata geometrica (Geometrical capacity / Débit géométrique / Geometrisch leistung / Caudal geométrico / Capacidade geométrico)	[l / min]	9.030	11.137	13.845
Regime di lavoro max / D (max rpm / tours maximum / max drehzahl / rpm max)	[rpm]	1400	1400	1400
Pressione max Assoluta (Relativa) Max absolute(relative) pressure / pression max absolue (relative) / max absolut (relativ) druck / presión max absoluta (relativa)	[bar]	2.5 (1.5)	2.5 (1.5)	2.5 (1.5)
Depressione senza valvola regolazione vuoto installata (Vacuum without depression valve fitted / vide sans soupape de depression montee / vakuum ohne eingebaute unterdruckventil / depresión sin válvula de vacío incorporada)	[bar]	-0.95	-0.95	-0.95
Depressione con valvola regolazione vuoto installata (Vacuum with depression valve fitted / vide avec soupape de depression montee / vakuum mit eingebaute unterdruckventil / depresión con válvula de vacío incorporada)	[bar]	-0.80	-0.80	-0.80
Ass. potenza a vuoto max, (power absorption per max vacuum / absorption puissance pour vide maximum / leistungsbedarf bei max vakuum / potencia absorbida max vacío)	[kW]	16	20	24
Ass. potenza a 2.5 bar assoluti, 1000 r.p.m. (power absorption at 2.5 bar absolute, 1000 rpm / absorption puissance a 2.5 bar absolute, 1000 rpm / leistungsbedarf zu 2.5 absolute 1000 rpm / potencia absorbida a 2.5 bar absoluta, 1000 rpm)	[kW]	25	30	36
Peso netto (net weight / poids net / netto-gewicht / peso neto)	[Kg]	132	147	165

# MEC/H

9000 - 11000 - 13500

The version / H has been projected to be driven by hydraulic motor.

La versione / H è stata ideata per essere azionata tramite motore idraulico.

La version / H a été projetée pour être actionnée par un moteur hydraulique.

In der Version / H die Antriebswelle (Zapfwelle) wird über einen hydraulischen Zahnradmotor betrieben.

La version / H ha sido concebida para ser accionada a través de un motor hidráulico.

A versão / H foi projectada para funcionar com motor hidráulico.

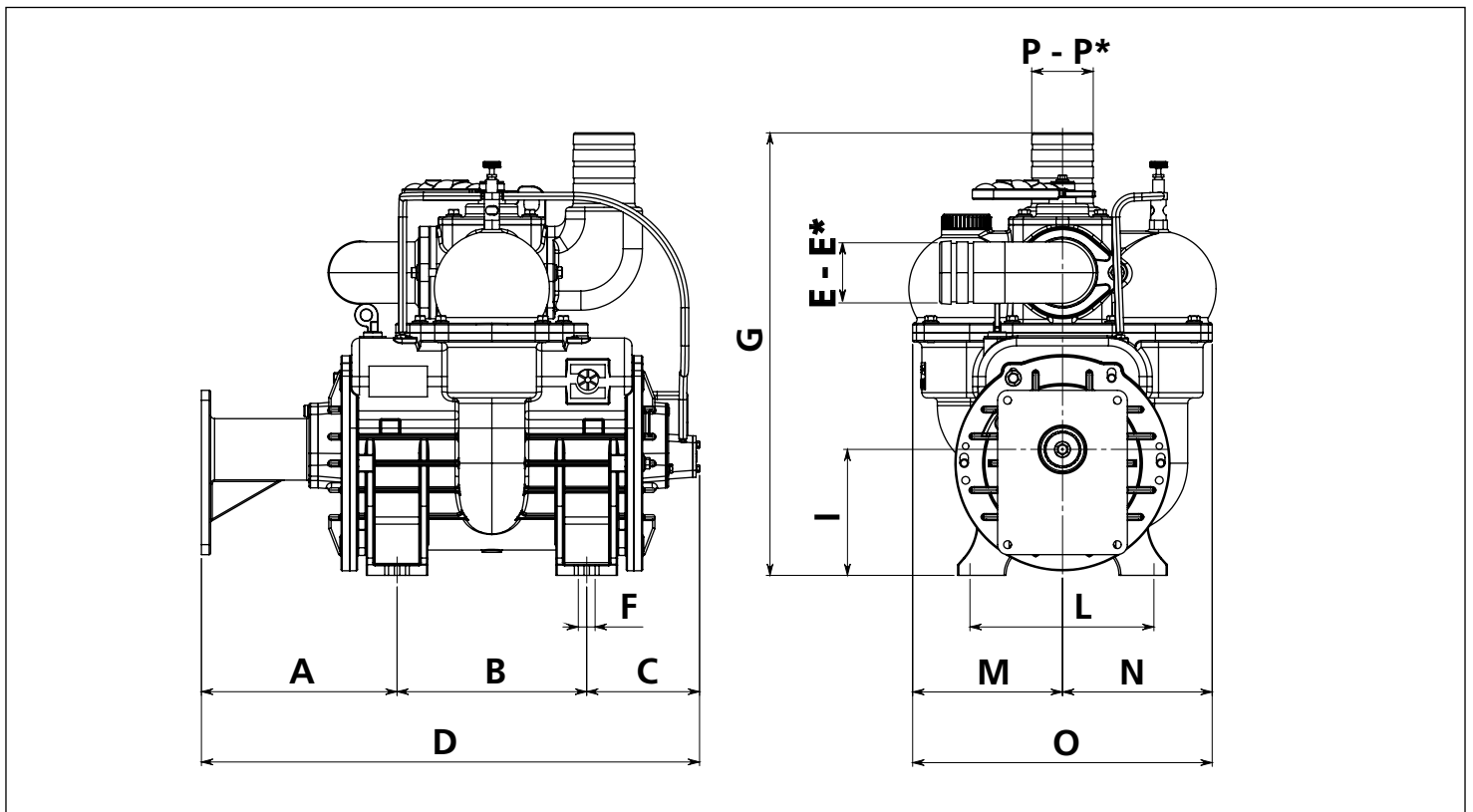

Article	A	B	C	D	E	E*	F	G	I	L	M	N	O	P	P*
MEC 9000 / H	247	189	141	577	80	76-100	22	575	164	246	195	195	390	80	76-100
MEC 11000 / H	254	247	147	648	100	76-80	22	575	164	246	195	195	390	100	76-80
MEC 13500 / H	299	247	192	738	100	76-80	22	575	164	246	195	195	390	100	76-80

## MEC 9000 H

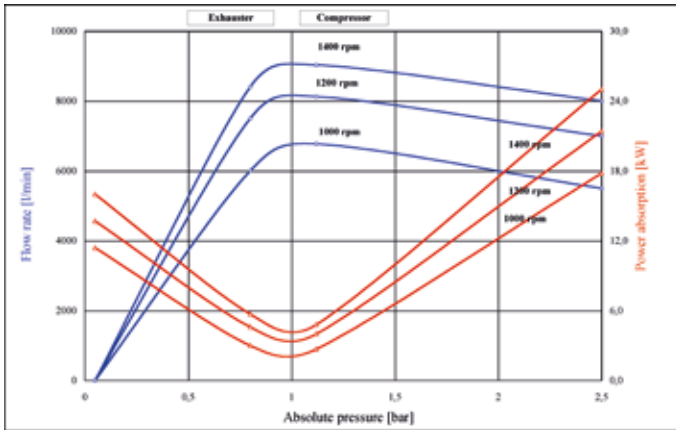

## MEC 11000 H

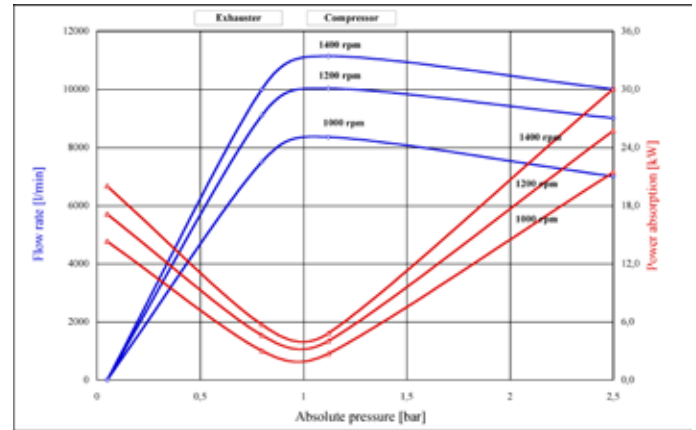

## MEC 13500 H

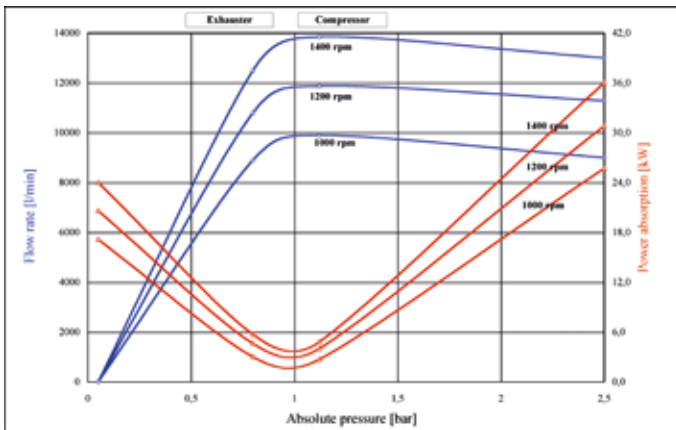

## HYDRAULIC SYSTEM

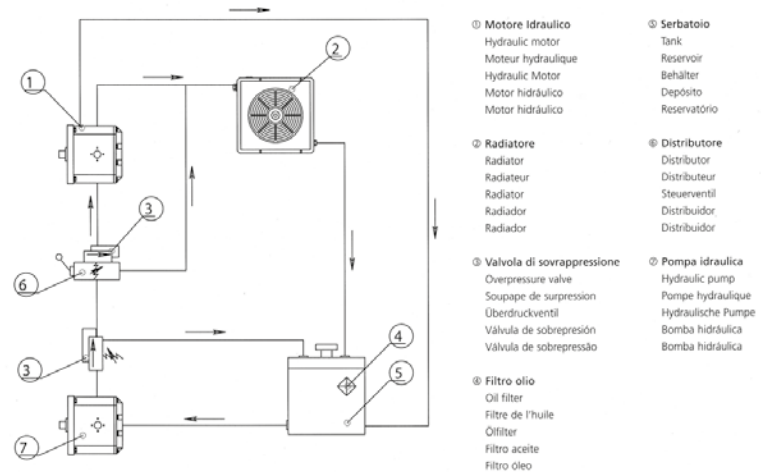

- ① Motore Idraulico  
Hydraulic motor  
Moteur hydraulique  
Hydraulic Motor  
Motor hidráulico  
Motor hidráulico
- ② Radiatore  
Radiator  
Radiateur  
Radiator  
Radiador  
Radiador
- ③ Valvola di sovrappressione  
Overpressure valve  
Soupape de surpression  
Überdruckventil  
Válvula de sobrepresión  
Válvula de sobrepresión
- ④ Filtro olio  
Oil filter  
Filtre de l'huile  
Oilfilter  
Filtro aceite  
Filtro oleo
- ⑤ Serbatoio  
Tank  
Reservoir  
Behälter  
Depósito  
Reservatório
- ⑥ Distributore  
Distributor  
Distributeur  
Distributeur  
Steuerventil  
Distribuidor  
Distribuidor
- ⑦ Pompa idraulica  
Hydraulic pump  
Pompe hydraulique  
Pompe hydraulique  
Hydraulische Pumpe  
Bomba hidráulica  
Bomba hidráulica

Code	Hydraulic Engine Motore Idraulico	Rotary vanes pump	Max Working Pressure Pressione Max Di Esercizio	Capacity Portata l/min	R.P.M. Giri/min	Pressure Pressione	Hydraulic System Max Pressure Pressione Max Impianto Idraulico	Output Potenza Trasmessa	Torque Coppia Nm	Article
6080200061	KM 40.87-S0	MEC 9000/H	1.5 bar	107	1400	174 bar	280 bar	30 kW	211	608/F
6080200061	KM 40.87-S0	MEC 11000/H	1.5 bar	107	1400	186 bar	280 bar	32 kW	226	608/F
6080200061	KM 40.87-S0	MEC 13500/H	1.5 bar	107	1400	198 bar	280 bar	34 kW	240	608/F

DATI TECNICI (technical data / données techniques / technische Daten / Datos tecnicos)		MEC 9000	MEC 11000	MEC 13500
Portata geometrica (Geometrical capacity / Débit géométrique / Geometrisch leistung / Caudal geométrico / Capacidade geométrico)	[l / min]	9.030	11.137	13.845
Regime di lavoro max / H (max rpm / tours maximum / max drehzahl / rpm max)	[rpm]	1400	1400	1400
Pressione max Assoluta (Relativa) Max absolute(relative) pressure / pression max absolue (relative) / max absolut (relativ) druck / presión max absoluta (relativa)	[bar]	2.5 (1.5)	2.5 (1.5)	2.5 (1.5)
Depressione senza valvola regolazione vuoto installata (Vacuum without depression valve fitted / vide sans soupape de depression montee / vakuum ohne eingebaute unterdruckventil / depresión sin válvula de vacío incorporada)	[bar]	-0.95	-0.95	-0.95
Depressione con valvola regolazione vuoto installata (Vacuum with depression valve fitted / vide avec soupape de depression montee / vakuum mit eingebaute unterdruckventil / depresión con válvula de vacío incorporada)	[bar]	-0.80	-0.80	-0.80
Ass. potenza a vuoto max, (power absorption per max vacuum / absorption puissance pour vide maximum / leistungsbedarf bei max vakuum / potencia absorbida max vacío)	[kW]	16	20	24
Ass. potenza a 2.5 bar assoluti, 1000 r.p.m. (power absorption at 2.5 bar absolute, 1000 rpm / absorption puissance a 2.5 bar absolue, 1000 rpm / leistungsbedarf zu 2.5 absolute 1000 rpm / potencia absorbida a 2.5 bar absoluta, 1000 rpm)	[kW]	25	30	36
Peso netto (net weight / poids net / netto-gewicht / peso neto)	[Kg]	140	155	173

# MEC/M-MA S.C.

9000 - 11000 - 13500



The version S.C. has been projected to be used as compressor for empty hose reel irrigators.

La versione S.C. è stato progettato per essere utilizzato come compressore per irrigatori.

La version S.C. a été conçu pour être utilisée comme compresseur pour enrouleurs.

Die Version S.C. projektiert wurde als Kompressor um Schlauchhaspel zu leeren.

La versión S.C. se ha proyectado para ser utilizado como compresor para vaciado de tuberías de sistemas de riego.

A versão S.C. foi projetado para ser usado como compresor para irrigantes.

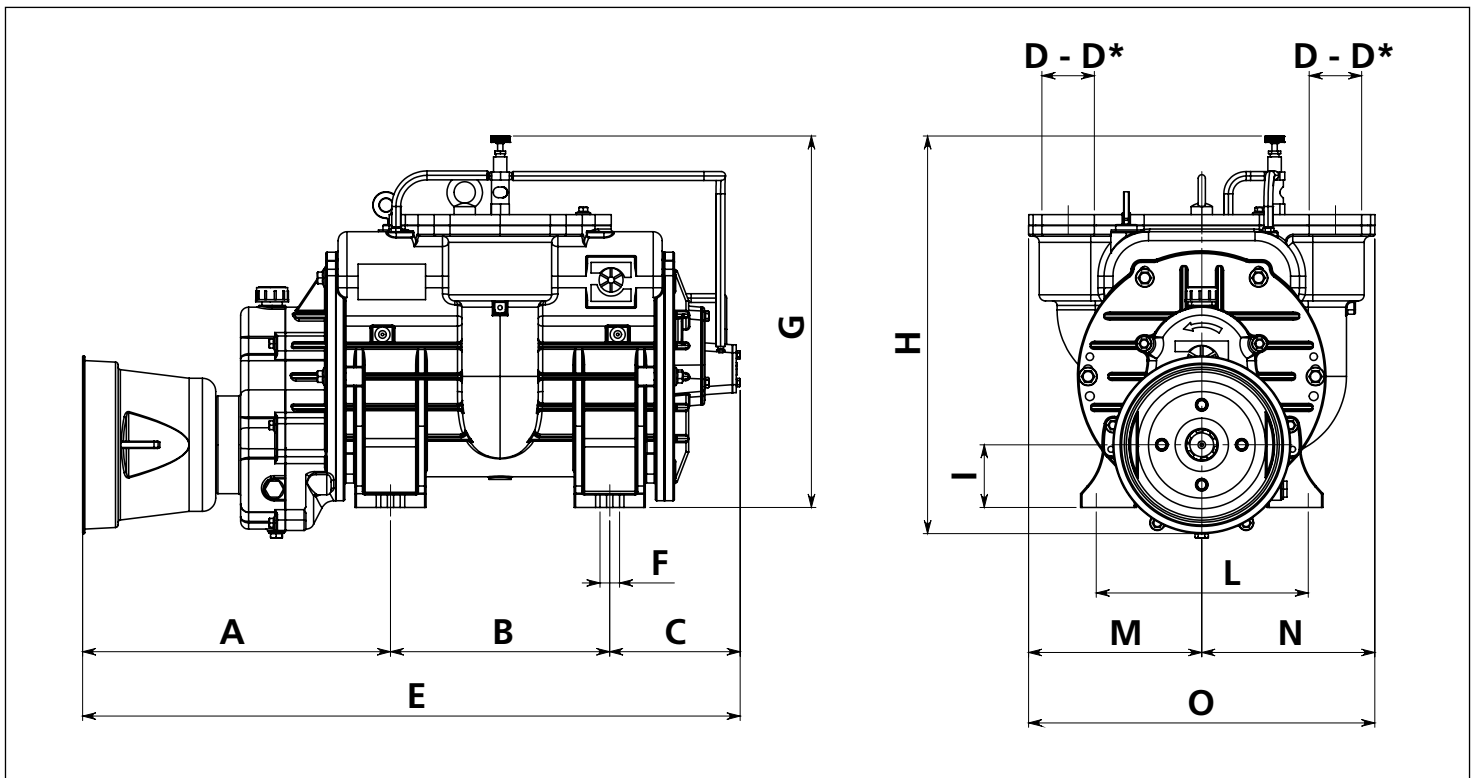
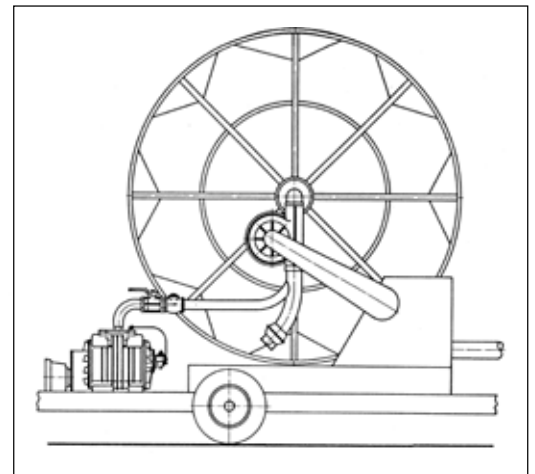

Article	A	B	C	D	D*	E	F	G	H	I	L	M	N	O
MEC 9000 / M-MA S.C.	340	189	141	2" GAS	2" 1/2 GAS	670	22	420	450	69	246	195	195	390
MEC 11000 / M-MA S.C.	346	247	147	2" 1/2 GAS	2" GAS	740	22	420	450	69	246	195	195	390
MEC 13500 / M-MA S.C.	391	247	192	2" 1/2 GAS	2" GAS	830	22	420	450	69	246	195	195	390

### MEC 9000 M - S.C.

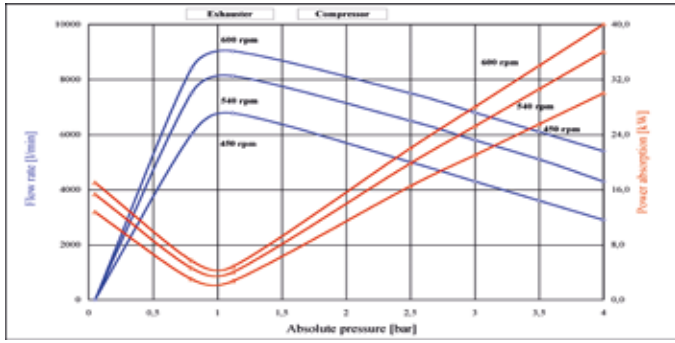

### MEC 9000 MA - S.C.

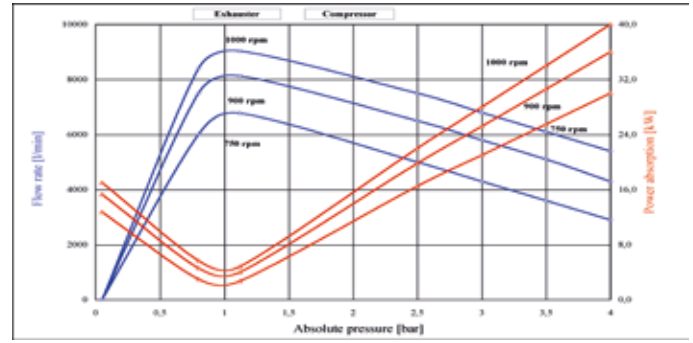

### MEC 11000 M - S.C.

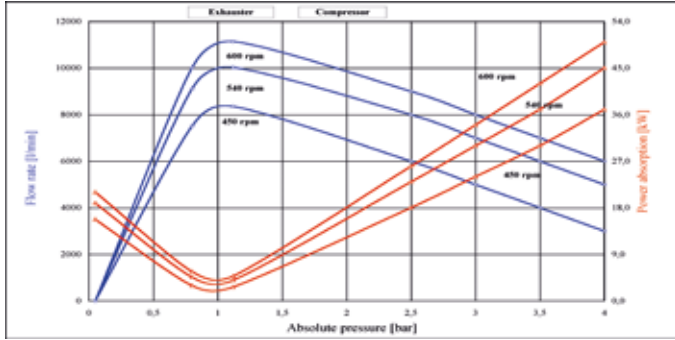

### MEC 11000 MA - S.C.

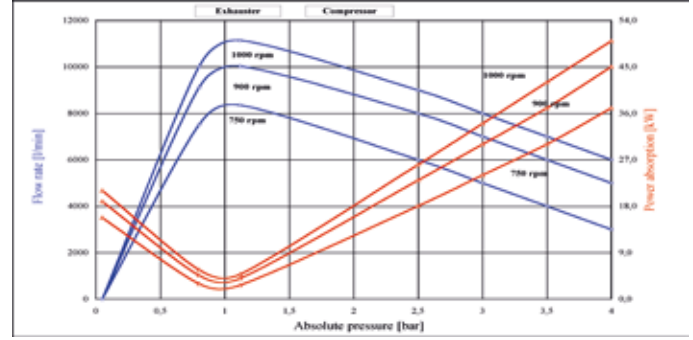

### MEC 13500 M - S.C.

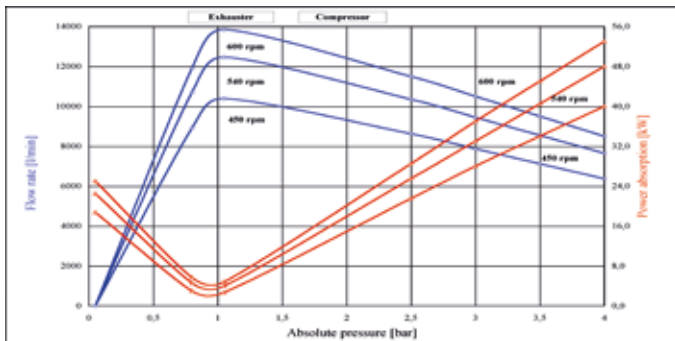

### MEC 13500 MA - S.C.

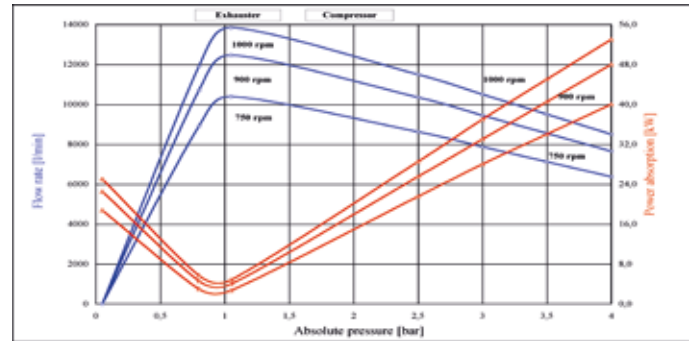

DATI TECNICI (technical data / données techniques / technische Daten / Datos técnicos)		MEC 9000	MEC 11000	MEC 13500
Portata geometrica (Geometrical capacity / Débit géométrique / Geometrisch leistung / Caudal geométrico / Capacidade geométrico)	[l / min]	9.030	11.137	13.845
Regime di lavoro max / M (max rpm / tours maximum / max drehzahl / rpm max)	[rpm]	600	600	600
Regime di lavoro max / MA (max rpm / tours maximum / max drehzahl / rpm max)	[rpm]	1000	1000	1000
Pressione max Assoluta (Relativa) Max absolute (relative) pressure / pression max absolue (relative) / max absolut (relativ) druck / presión max absoluta (relativa)	[bar]	4 (3)	4 (3)	4 (3)
Ass. potenza a 2.5 bar assoluti, 600 r.p.m. (power absorption at 2.5 bar absolute, 600 rpm / absorption puissance a 2.5 bar absolue, 600 rpm / leistungsbearf zu 2.5 bar absolute, 600 rpm / potencia absorbida a 2.5 bar absoluta, 600 rpm)	[kW]	46	50	54
Ass. potenza a 2.5 bar assoluti, 1000 r.p.m. (power absorption at 2.5 bar absolute, 1000 rpm / absorption puissance a 2.5 bar absolue, 1000 rpm / leistungsbearf zu 2.5 absolute 1000 rpm / potencia absorbida a 2.5 bar absoluta, 1000 rpm)	[kW]	46	50	54
Peso netto (net weight / poids net / netto-gewicht / peso neto)	[Kg]	118	133	151

## VERSIONS

versioni / versions / Versionen



**MEC BALLAST** 65% vacuum in continuous work  
65% di vuoto in servizio continuo  
65% vide pendant travail continu  
65% Vakuum bei andauernder Arbeit  
Trabajo continuo en el vacío del 65%  
Trabalho contínuo no vácuo de 65%

## ON REQUEST

A domanda / Sur demande / Auf Anfrage  
A petición / Por encomenda

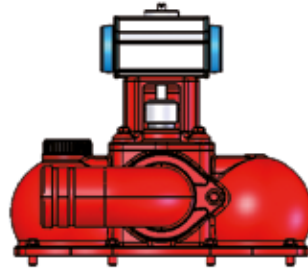

Code 6080200085 : MEC 9000/11000/13500

### PNEUMATIC REVOLVING HOUSING

Cilindro rotativo pneumático  
Cylindre rotatif pneumatique  
Pneumatischer Schaltungszylinder  
Cilindro rotativo neumático  
Cilindro rotativo pneumático



Code 5090000010: MEC 9000/11000/13500

### HYDRAULIC REVOLVING HOUSING

Cilindro rotativo hidráulico  
Cylindre rotatif hydraulique  
Hydraulischer Schaltungszylinder  
Cilindro rotativo hidráulico  
Cilindro rotativo hidráulico

## LEVER FOR PUMP UNI EN 707

LEVA PER POMPE UNI EN 707

LEVIER POMPE UNI EN 707

HEBEL PUMP UNI EN 707



Code 6080200163 : MEC 9000/11000/13500

## LUBRICATION SYSTEM

Sistema di lubrificazione / Système de lubrification  
Schmierungssystem / Sistema de lubricación / Sistema di lubrificação

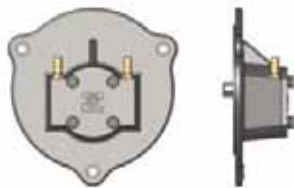

### FORCED AS SERIES

Forzata di serie  
Forcée de série  
Druckschmierung als Serie  
Força da de série  
Forçada de série



### AUTOMATIC ON REQUEST

Automatica a richiesta  
Automatique sur demande  
Automatische auf Anfrage  
Automática, bajo pedido  
Automática por encomenda

## FITTING

(Accessori / Accessoires / Zubehoerteilen)



Code 6100200025 : MEC 9000  
Code 6100200026 : MEC 11000/13500  
Code 6100200027 : MEC 9000  
Code 6100200028 : MEC 11000/13500

### PRIMARY SHUT-OFF VALVE (BPT-BPU)

Valvola primaria / Soupape primaire /  
Primärsventil / Válvula primaria / Válvula primária



Code 6100200021 : MEC 9000  
Code 6100200022 : MEC 11000/13500

### SECONDARY SHUT-OFF VALVE (BPR-BPS)

Valvola Secondaria / Soupape secondaire /  
Sekundärsventil / Válvula secundaria / Válvula secundária



Code 5090000065: MEC 9000  
Code 5090000066: MEC 11000 / 13500

### SILENCER

Silenziatore  
silencieux  
Schalldämpfer

# FITTINGS

(Accessori / Accessoires / Zubehorteilen)



Code 5090000025: MEC 9000  
Code 5090000026: MEC 11000/13500



Code 5090000046: MEC 9000  
Code 5090000047: MEC 11000/13500

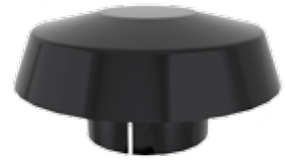

Code 5090000061: MEC 9000  
Code 5090000062: MEC 11000/13500

## FILTER - SILENCER

Filtro silenziatore / Filtre - silencieux / Filter - Schalldämpfer  
Filtro - Silenciador / Filtro - Supressor do ruído

## PREFILTER FOR SILENCER

Prefiltro per silenziatore / Prefiltre pour silencieux / Zyklon

## RAIN CAPS

Cappello parapioggia / Couvercle / Regenkappen



Code 5090000069: MEC 9000



Code 5100200011: MEC 9000 / 11000 / 13500



Code 5100200012: MEC 9000 / 11000 / 13500

## FINAL AIR FILTER

Filtro aria finale / Filtro aria finale  
Filtre a air final / Trockenluftfilter final

## OVERPRESSURE VALVE

Valvola sovrappressione / Soupape de surpression  
Überdruckventil / Válvula de sobrepresión  
Válvula de sobrepresão

## DEPRESSION VALVE NOT CALIBRATED

Valvola di regolazione vuoto non tarata /  
soupape de depression pas tarée /  
unterdruckventil nicht geeicht



Code 5100100001: Ø 100  
Code 5100100002: Ø 150  
Code 5100100003: Ø 200  
Code 5100100004: Ø 250



Code 6080200156: Ø 200  
Code 6080200165: Ø 250



Code 6080200134: Ø 150 MANUAL  
Code 6080200135: Ø 200 MANUAL  
Code 6080200136: Ø 150 HYDRAULIC  
Code 6080200137: Ø 200 HYDRAULIC  
Code 6080200142: Ø 150 PNEUMATIC  
Code 6080200143: Ø 200 PNEUMATIC

## SWIVEL JOINT

Giunto girevole / Rotule / Drehbare Kupplung / Nudo girabile

## HYDRAULIC SWIVEL JOINT

Giunto girevole idraulico / Rotule hydraulique /  
Hydraulische dehbare Kupplung

## BPP KNIFE GATE VALVE

Version:  
Lever / Leva  
Hydraulic cylinder / Cilindro idraulico  
Pneumatic cylinder / Cilindro pneumático

All specifications are subject to change without notice.  
Le specifiche sono soggette a cambiamento senza preavviso.  
Les caractéristiques techniques peuvent être modifiées à tout moment et sans préavis.  
Die Spezifikationen können ohne Vorankündigung geändert werden.



**STEM GATE**  
*SARACINESCA*

## **HYDRAULIC SWIVEL JOINT**

*GIUNTO GIREVOLE MOTORIZZATO*

## **PRIMARY VALVE**

*VALVOLA PRIMARIA*

## **SECONDARY VALVE**

*VALVOLA SECONDARIA*

## **FILTER-SILENCER**

*SILENZIATORE CON FILTRO*

## **SWIVEL JOINT**

*GIUNTO GIREVOLE*

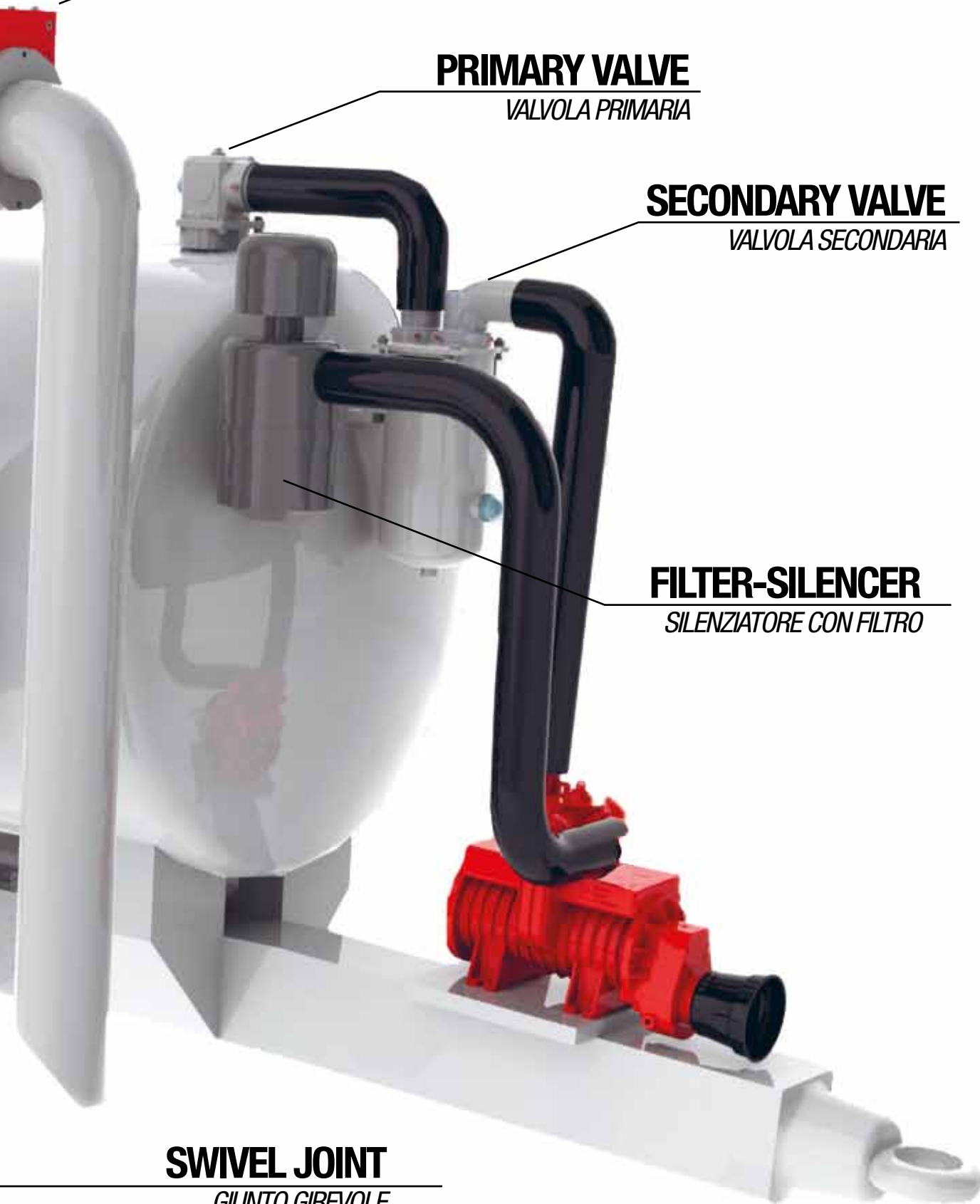

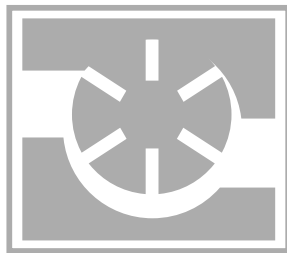

**Battioni®**  
**Pagani**  
**Pompe**

LOGO IN  
INGLESE  
verde (misto  
di AGC



This catalog is printed entirely on  
FSC certified paper (Forest Stewardship Council)  
produced using cellulose from responsibly managed forests,  
according to strict environmental, social and economic standard.

**Battioni Pagani Pompe®** has demonstrated its commitment  
to protect and safeguard of the environment  
and forest resources with the purchase of certified paper.

Questo catalogo è interamente stampato  
su carta certificata FSC (Forest Stewardship Council), prodotta  
con cellulosa proveniente da foreste gestite in modo responsabile,  
secondo rigorosi standard ambientali, sociali ed economici.

**Battioni Pagani Pompe®** ha dimostrato il suo impegno  
per la tutela e la salvaguardia dell'ambiente  
e delle risorse forestali nell'acquisto della carta certificata.



Battioni®  
Pagani  
Pompe

**motralec**

4 rue Lavoisier . ZA Lavoisier . 95223 HERBLAY CEDEX  
Tel. : 01.39.97.65.10 / Fax. : 01.39.97.68.48  
Demande de prix / e-mail : [service-commercial@motralec.com](mailto:service-commercial@motralec.com)  
[www.motralec.com](http://www.motralec.com)