

Vertical Multi-stage Pumps - 60 Hz.

PVM - Cast Iron
PVM I - 304 Stainless Steel
PVM X - 316 Stainless Steel

Models	Flow Series	HP Range	GPM
PVM/PVM I/PVM X	2	1/2 – 5	1 – 20
PVM/PVM I/PVM X	4	1/2 – 7.5	3 – 40
PVM/PVM I/PVM X	8	3/4 – 15	5 – 65
PVM/PVM I/PVM X	16	5 – 25	8 – 115
PVM	32	3 – 40	15 – 215

TABLE OF CONTENTS

Description	Page
PVM(I/X)2 Series	2-8
PVM(I/X)4 Series	9-15
PVM(I/X)2 /PVM(I/X)4 Construction Materials	16
PVM(I/X)8 Series	17-23
PVM(I/X)16 Series	24-28
PVM(I/X)8/PVM(I/X)16 Construction Materials	29
PVM32 Series	30-33
PVM32 Construction Materials	34
Bypass Orifice Sizing	35
Warranty	36

VERTICAL MULTI-STAGE PERFORMANCE

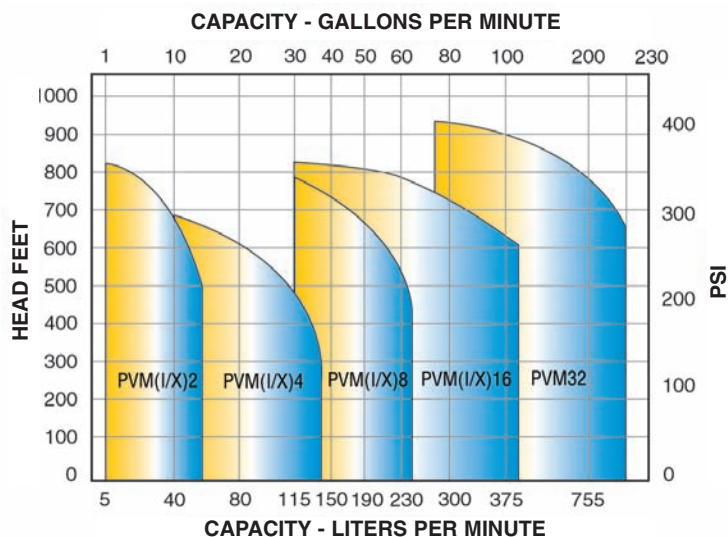

PVM (I/X) 2 SERIES



Performance Curves – PVM (I/X) 2 Series

Nominal RPM: 3450
 Based on Fresh Water @ 68 F.
 Maximum Working Pressure: 360 PSI

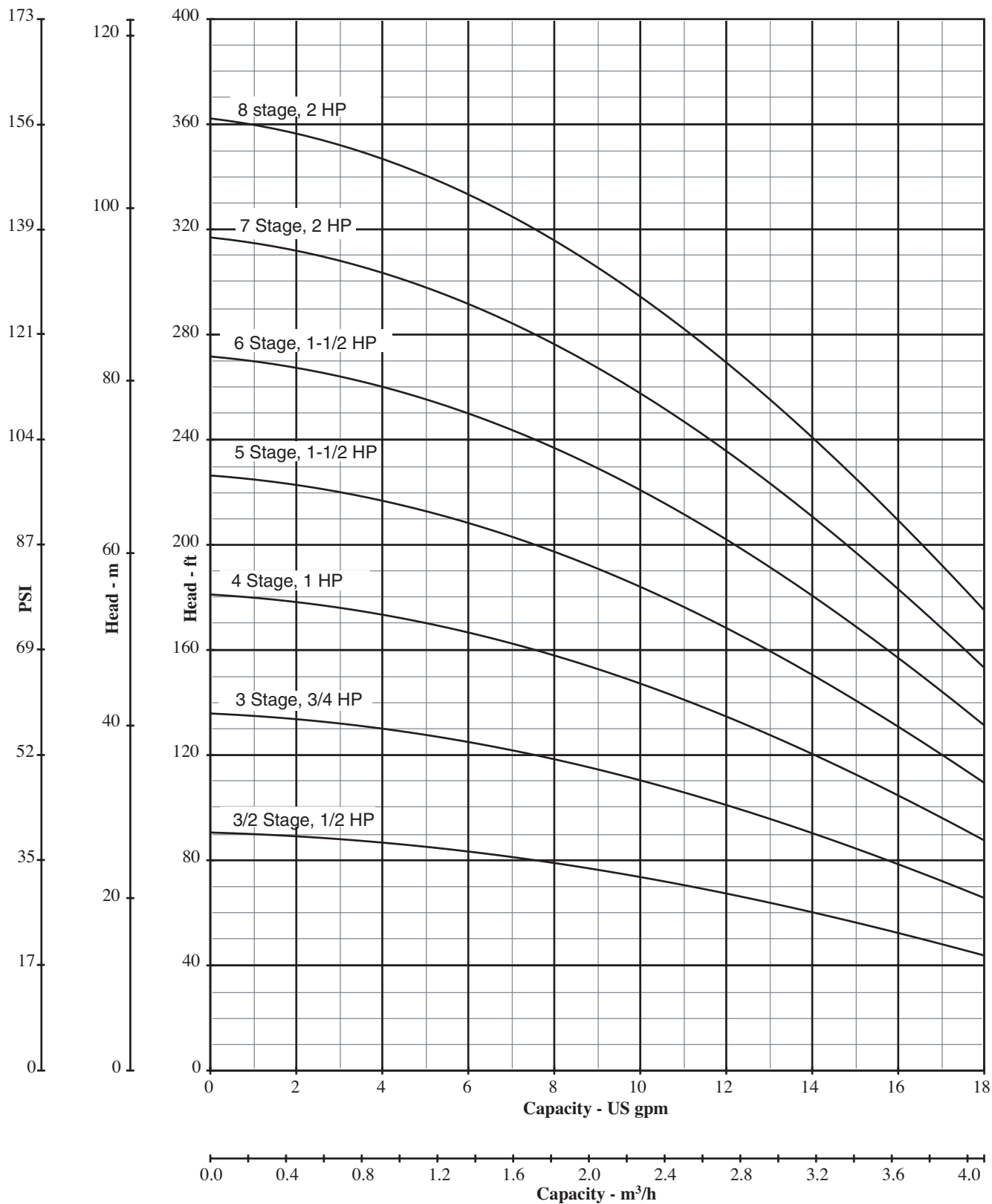

Performance Curves – PVM (I/X) 2 Series

Nominal RPM: 3450
Based on Fresh Water @ 68 F.
Maximum Working Pressure: 360 PSI

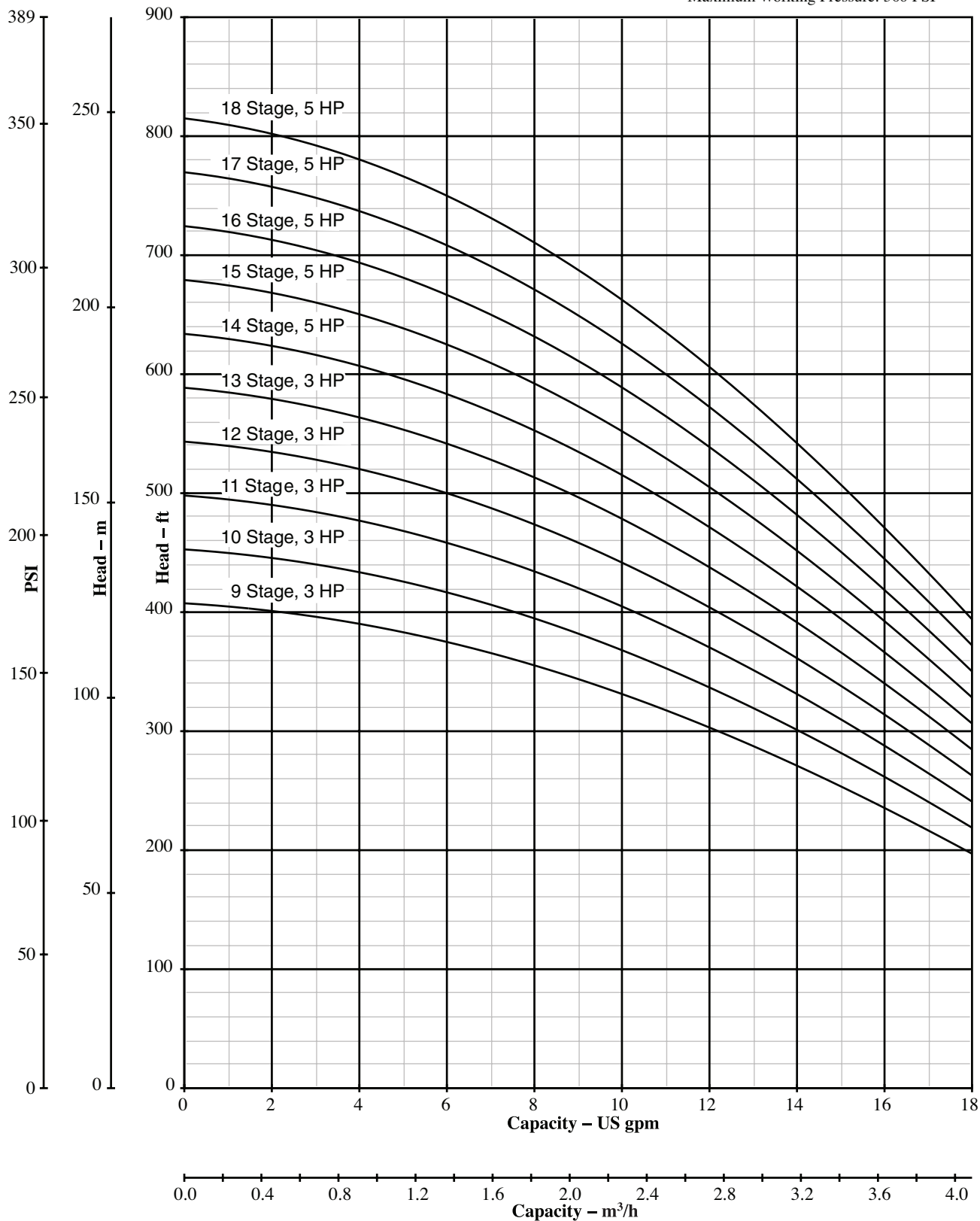

Single Stage Performance Data – PVM (I/X) 2 Series

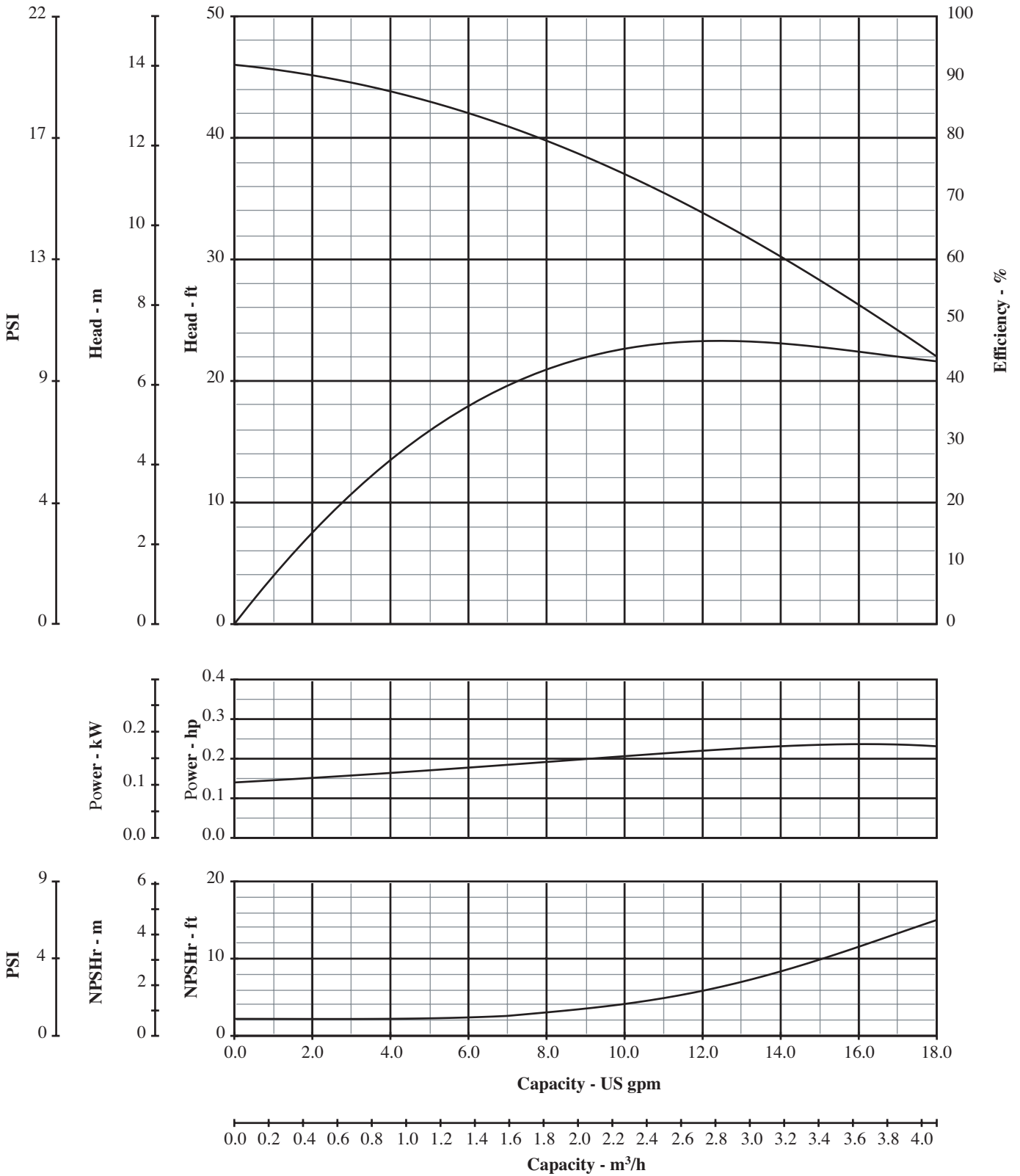

Cast Iron Construction

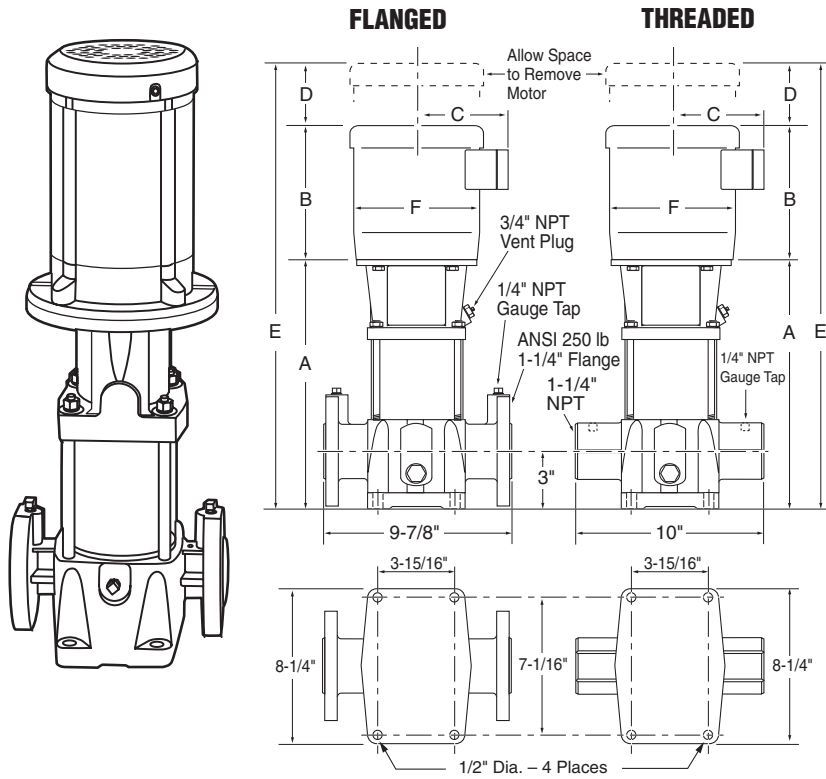

Technical Information

- MINIMUM PUMPING RATES:** 1.2 GPM
- FLOW RANGE:** 1.2 – 20 GPM
- MINIMUM SUCTION PIPE SIZES:**
1-1/4" Nominal Diameter, Schedule 40 Pipe
- MAXIMUM INLET PRESSURE:**
30/2 - 60 – 145 PSI
70 - 180 – 220 PSI
- MAXIMUM AMBIENT TEMPERATURE:** 104° F
- LIQUID TEMPERATURE RANGE:** +5° F to +250° F
- MOTOR OPTIONS:** TEFC or ODP
- CONSTRUCTION MATERIALS:** See Page 16.

1-1/4" ANSI. 250 lb. 4-Bolt Flange

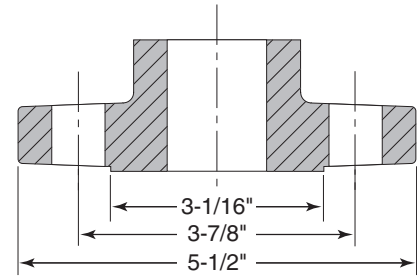

Dimensions and Specifications – PVM 2 Series 1/2 thru 2 HP

Model Number	HP	Motor S.F.	Ph	Volts	Frame Size	Disc. Size	Suc. Size	Dimension in Inches*						TEFC Wt.	ODP Wt.
								A	B	C	D	E	F		
PVM2-30/2	0.5	1.25	1	115/208-230	56C	1-1/4	1-1/4	11-3/8	9-1/4	4-7/8	2	22-5/8	6	80	78
PVM2-30/2	0.5	1.25	3	208-230/460	56C	1-1/4	1-1/4	11-3/8	9-1/4	4-7/8	2	22-5/8	6	77	75
PVM2-30	0.75	1.25	1	115/208-230	56C	1-1/4	1-1/4	11-3/8	9-7/8	4-7/8	2	23-1/4	6	84	86
PVM2-30	0.75	1.25	3	208-230/460	56C	1-1/4	1-1/4	11-3/8	9-1/4	4-7/8	2	22-5/8	6	79	78
PVM2-40	1	1.25	1	115/208-230	56C	1-1/4	1-1/4	12	11-1/8	5-1/4	2	25-1/4	7-1/8	96	89
PVM2-40	1	1.25	3	208-230/460	56C	1-1/4	1-1/4	12	9-1/4	4-7/8	2	23-3/8	6	80	83
PVM2-50	1.5	1.15	1	115/208-230	56C	1-1/4	1-1/4	12-3/4	11-1/8	5-5/8	2	26	7-1/8	101	96
PVM2-50	1.5	1.15	3	208-230/460	56C	1-1/4	1-1/4	12-3/4	10-1/8	5-3/4	2-1/8	25	7-1/4	90	89
PVM2-60	1.5	1.15	1	115/208-230	56C	1-1/4	1-1/4	13-1/2	11-1/8	5-5/8	2	26-5/8	7-1/8	102	97
PVM2-60	1.5	1.15	3	208-230/460	56C	1-1/4	1-1/4	13-1/2	10-1/8	5-3/4	2-1/8	25-3/4	7-1/4	91	90
PVM2-70	2	1.15	1	208-230	56C	1-1/4	1-1/4	14-1/8	12-1/8	5-5/8	2	28-1/4	7-1/8	110	103
PVM2-70	2	1.15	3	208-230/460	56C	1-1/4	1-1/4	14-1/8	11-1/8	5-3/4	2-1/8	27-3/8	7-1/4	100	94
PVM2-80	2	1.15	1	208-230	56C	1-1/4	1-1/4	14-7/8	12-1/8	5-5/8	2	29	7-1/8	111	104
PVM2-80	2	1.15	3	208-230/460	56C	1-1/4	1-1/4	14-7/8	11-1/8	5-3/4	2-1/8	28-1/8	7-1/4	101	95

* Measurements represent the largest number possible for each model using standard efficiency motors.
Weight may vary from published information.

Cast Iron Construction

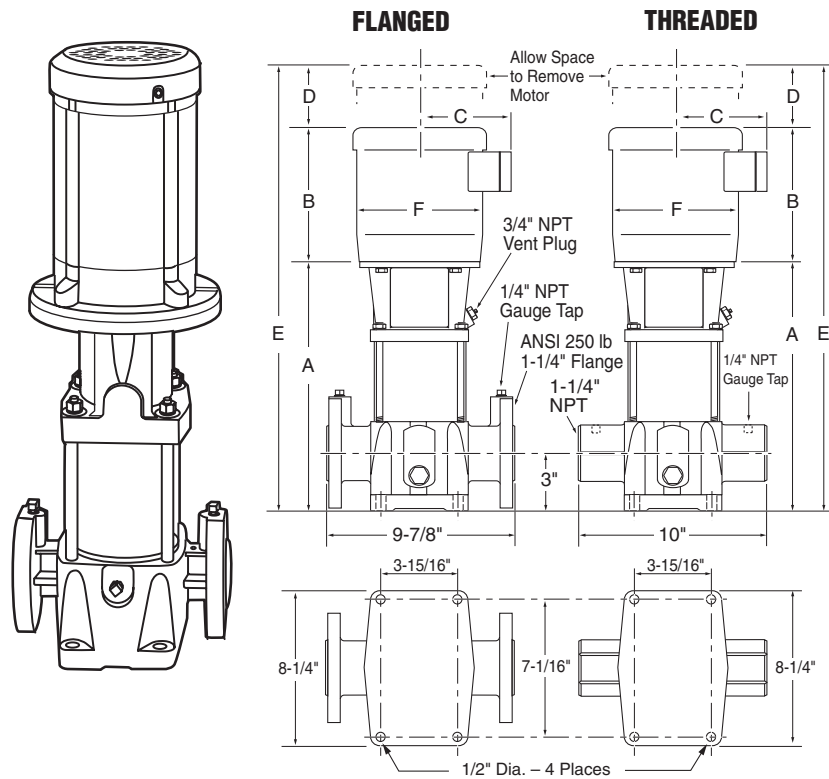

Technical Information

- MINIMUM PUMPING RATES:** 1.2 GPM
- FLOW RANGE:** 1.2 – 20 GPM
- MINIMUM SUCTION PIPE SIZES:**
1-1/4" Nominal Diameter, Schedule 40 Pipe
- MAXIMUM INLET PRESSURE:**
30/2 - 60 – 145 PSI
70 - 180 – 220 PSI
- MAXIMUM AMBIENT TEMPERATURE:** 104° F
- LIQUID TEMPERATURE RANGE:** +5° F to +250° F
- MOTOR OPTIONS:** TEFC or ODP
- CONSTRUCTION MATERIALS:** See Page 16.

1-1/4" ANSI. 250 lb. 4-Bolt Flange

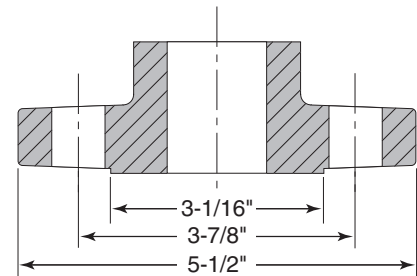

Dimensions and Specifications – PVM 2 Series 3 thru 5 HP

Model Number	HP	Motor S.F.	Ph	Volts	Frame Size	Disc. Size	Suc. Size	Dimension in Inches*						TEFC Wt.	ODP Wt.
								A	B	C	D	E	F		
PVM2-90	3	1.15	1	115/208-230	182TC	1-1/4	1-1/4	16	13-5/8	6 7/8	2-3/4	32-3/8	8-1/2	143	134
PVM2-90	3	1.15	3	208-230/460	182TC	1-1/4	1-1/4	16	12-1/4	6 7/8	2-7/8	31-1/8	8-1/2	124	124
PVM2-100	3	1.15	1	208-230	182TC	1-1/4	1-1/4	16-5/8	13-5/8	6-7/8	2-3/4	33-1/8	8-1/2	144	135
PVM2-100	3	1.15	3	208-230/460	182TC	1-1/4	1-1/4	16-5/8	12-1/4	6-7/8	2-7/8	31-7/8	8-1/2	125	125
PVM2-110	3	1.15	1	115/208-230	182TC	1-1/4	1-1/4	17-3/8	13 5/8	6 7/8	2-3/4	33-3/4	8-1/2	145	136
PVM2-110	3	1.15	3	208-230/460	182TC	1-1/4	1-1/4	17-3/8	12-1/4	6 7/8	2-7/8	32-1/2	8-1/2	126	126
PVM2-120	3	1.15	1	208-230	182TC	1-1/4	1-1/4	18-1/8	13-5/8	6-7/8	2-3/4	34-1/2	8-1/2	146	137
PVM2-120	3	1.15	3	208-230/460	182TC	1-1/4	1-1/4	18-1/8	12-1/4	6-7/8	2-7/8	33-1/4	8-1/2	127	127
PVM2-130	3	1.15	1	115/208-230	182TC	1-1/4	1-1/4	18-3/4	13-5/8	6 7/8	2-3/4	35-1/4	8-1/2	147	138
PVM2-130	3	1.15	3	208-230/460	182TC	1-1/4	1-1/4	18-3/4	12-1/4	6 7/8	2-7/8	34	8-1/2	128	128
PVM2-140	5	1.15	1	208-230	213TCZ	1-1/4	1-1/4	19-1/2	15-1/4	8	3-3/8	38-1/8	10-5/8	180	154
PVM2-140	5	1.15	3	208-230/460	184TC	1-1/4	1-1/4	19-1/2	13-5/8	6 7/8	2-7/8	36	8-1/2	153	150
PVM2-150	5	1.15	1	208-230	213TCZ	1-1/4	1-1/4	20-1/4	15-1/4	8	3-3/8	38-7/8	10-5/8	155	155
PVM2-150	5	1.15	3	208-230/460	184TC	1-1/4	1-1/4	20-1/4	13-5/8	6-7/8	2-7/8	36-3/4	8-1/2	154	151
PVM2-160	5	1.15	1	208-230	213TCZ	1-1/4	1-1/4	20-7/8	15-1/4	8	3-3/8	39-5/8	10-5/8	182	156
PVM2-160	5	1.15	3	208-230/460	184TC	1-1/4	1-1/4	20-7/8	13-5/8	6 7/8	2-7/8	37-1/2	8-1/2	155	152
PVM2-170	5	1.15	1	208-230	213TCZ	1-1/4	1-1/4	21-5/8	15-1/4	8	3-3/8	40-1/4	10-5/8	183	157
PVM2-170	5	1.15	3	208-230/460	184TC	1-1/4	1-1/4	21-5/8	13-5/8	6 7/8	2-7/8	38-1/8	8-1/2	156	153
PVM2-180	5	1.15	1	208-230	213TCZ	1-1/4	1-1/4	22-3/8	15-1/4	8	3-3/8	41	10-5/8	184	158
PVM2-180	5	1.15	3	208-230/460	184TC	1-1/4	1-1/4	22-3/8	13-5/8	6-7/8	2-7/8	38-7/8	8-1/2	157	154

* Measurements represent the largest number possible for each model using standard efficiency motors.
Weight may vary from published information.

PVM (I/X) 2 SERIES

304 SS and 316 SS Construction

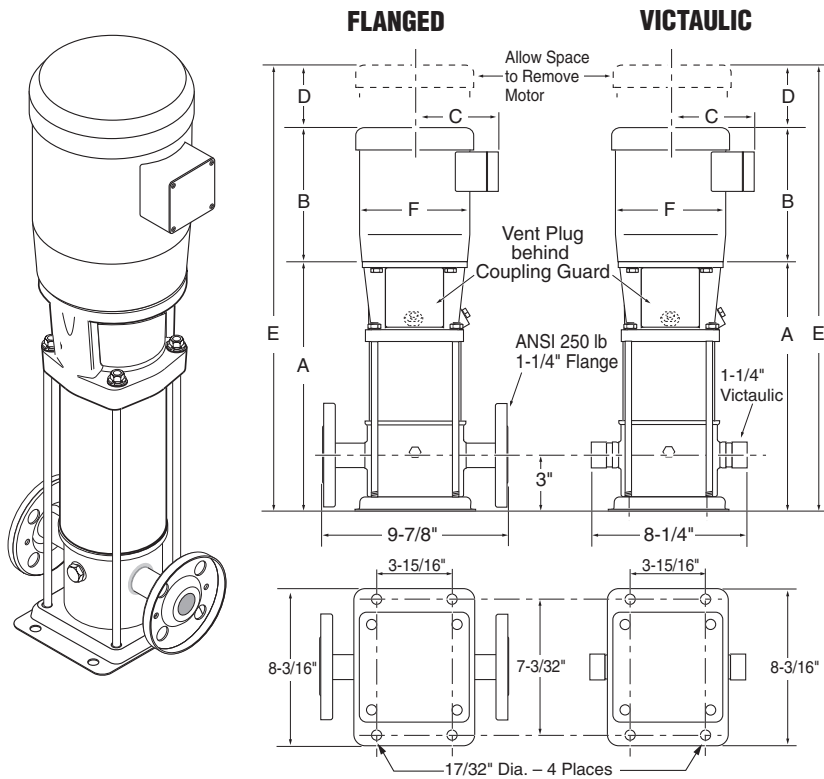

Technical Information

- MINIMUM PUMPING RATES:** 1.2 GPM
- FLOW RANGE:** 1.2 – 20 GPM
- MINIMUM SUCTION PIPE SIZES:**
1-1/4" Nominal Diameter, Schedule 40 Pipe
- MAXIMUM INLET PRESSURE:**
30/2 - 60 – 145 PSI
70 - 180 – 220 PSI
- MAXIMUM AMBIENT TEMPERATURE:** 104° F
- LIQUID TEMPERATURE RANGE:** +5° F to +250° F
- MOTOR OPTIONS:** TEFC or ODP
- CONSTRUCTION MATERIALS:** See Page 16.

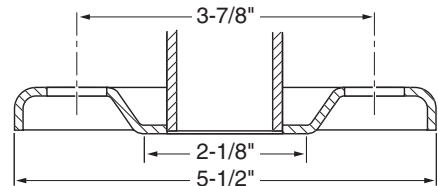

Dimensions and Specifications – PVM (I/X) 2 Series†

1/2 thru 2 HP

Model Number†	HP	Motor S.F.	Ph	Volts	Frame Size	Disc. Size	Suc. Size	Dimension in Inches*						TEFC Wt.	ODP Wt.
								A	B	C	D	E	F		
PVM(I/X)2-30/2	0.5	1.25	1	115/208-230	56C	1-1/4	1-1/4	11-3/4	9-1/4	4-7/8	2	23	6	68	66
PVM(I/X)2-30/2	0.5	1.25	3	208-230/460	56C	1-1/4	1-1/4	11-3/4	9-1/4	4-7/8	2	23	6	65	63
PVM(I/X)2-30	0.75	1.25	1	115/208-230	56C	1-1/4	1-1/4	11-3/4	9-7/8	4-7/8	2	23-5/8	6	72	74
PVM(I/X)2-30	0.75	1.25	3	208-230/460	56C	1-1/4	1-1/4	11-3/4	9-7/8	4-7/8	2	23-5/8	6	67	66
PVM(I/X)2-40	1	1.25	1	115/208-230	56C	1-1/4	1-1/4	12-3/8	11-1/8	5-1/4	2	25-5/8	7-1/8	84	77
PVM(I/X)2-40	1	1.25	3	208-230/460	56C	1-1/4	1-1/4	12-3/8	11-1/8	5-1/4	2	25-5/8	7-1/8	68	71
PVM(I/X)2-50	1.5	1.15	1	115/208-230	56C	1-1/4	1-1/4	13-1/8	11-1/8	5-3/4	2-1/8	26-3/8	7-1/4	89	84
PVM(I/X)2-50	1.5	1.15	3	208-230/460	56C	1-1/4	1-1/4	13-1/8	11-1/8	5-3/4	2-1/8	26-3/8	7-1/4	78	77
PVM(I/X)2-60	1.5	1.15	1	115/208-230	56C	1-1/4	1-1/4	13-7/8	11-1/8	5-3/4	2-1/8	27	7-1/7	90	85
PVM(I/X)2-60	1.5	1.15	3	208-230/460	56C	1-1/4	1-1/4	13-7/8	11-1/8	5-3/4	2-1/8	27	7-1/4	79	78
PVM(I/X)2-70	2	1.15	1	208-230	56C	1-1/4	1-1/4	14-1/2	12-1/8	5-3/4	2-1/8	28-5/8	7-1/4	98	91
PVM(I/X)2-70	2	1.15	3	208-230/460	56C	1-1/4	1-1/4	14-1/2	12-1/8	5-3/4	2-1/8	28-5/8	7-1/4	88	82
PVM(I/X)2-80	2	1.15	1	208-230	56C	1-1/4	1-1/4	15-1/4	12-1/8	5-3/4	2-1/8	29-3/8	7-1/4	99	92
PVM(I/X)2-80	2	1.15	3	208-230/460	56C	1-1/4	1-1/4	15-1/4	12-1/8	5-3/4	2-1/8	29-3/8	7-1/4	89	83

* Measurements represent the largest number possible for each model using standard efficiency motors.

† Includes PMVI models constructed of 304 Stainless Steel and PVMX models constructed of 316 Stainless Steel.

PVM (I/X) 2 SERIES

304 SS and 316 SS Construction

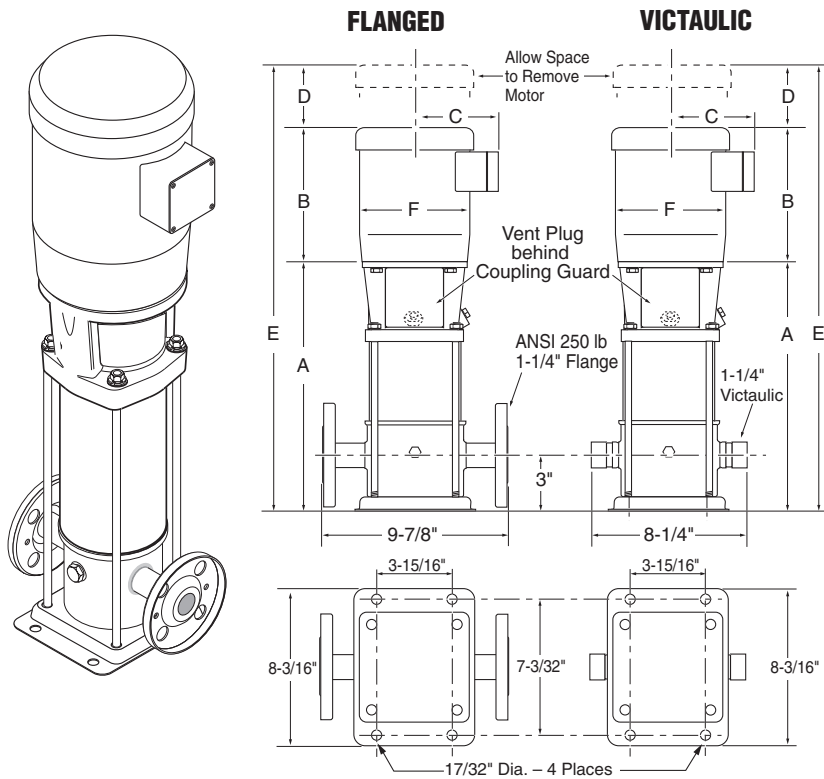

Technical Information

- MINIMUM PUMPING RATES:** 1.2 GPM
- FLOW RANGE:** 1.2 – 20 GPM
- MINIMUM SUCTION PIPE SIZES:**
1-1/4" Nominal Diameter, Schedule 40 Pipe
- MAXIMUM INLET PRESSURE:**
30/2 - 60 – 145 PSI
70 - 180 – 220 PSI
- MAXIMUM AMBIENT TEMPERATURE:** 104° F
- LIQUID TEMPERATURE RANGE:** +5° F to +250° F
- MOTOR OPTIONS:** TEFC or ODP
- CONSTRUCTION MATERIALS:** See Page 16.

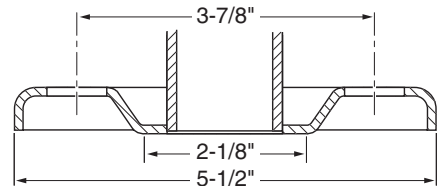

Dimensions and Specifications – PVM (I/X) 2 Series†

3 thru 5 HP

Model Number†	HP	Motor S.F.	Ph	Volts	Frame Size	Disc. Size	Suc. Size	Dimension in Inches*						TEFC Wt.	ODP Wt.
								A	B	C	D	E	F		
PVM(I/X)2-90	3	1.15	1	115/208-230	182TC	1-1/4	1-1/4	16-3/8	12-1/4	6-7/8	2-7/8	31-1/2	8-1/2	131	122
PVM(I/X)2-90	3	1.15	3	230/460	182TC	1-1/4	1-1/4	16-3/8	10-1/4	6-7/8	2-7/8	29-1/2	8-1/2	112	112
PVM(I/X)2-100	3	1.15	1	208-230	182TC	1-1/4	1-1/4	17	13-5/8	2-5/8	2-7/8	33-5/8	8-1/2	132	123
PVM(I/X)2-100	3	1.15	3	208-230/460	182TC	1-1/4	1-1/4	17	13-5/8	2-5/8	2-7/8	33-5/8	8-1/2	113	113
PVM(I/X)2-110	3	1.15	1	115/208-230	182TC	1-1/4	1-1/4	17-3/4	12-1/4	6-7/8	2-3/4	32-7/8	8-1/2	133	124
PVM(I/X)2-110	3	1.15	3	230/460	182TC	1-1/4	1-1/4	17-3/4	10-1/4	6-7/8	2-7/8	30-7/8	8-1/2	114	114
PVM(I/X)2-120	3	1.15	1	208-230	182TC	1-1/4	1-1/4	18-1/2	13-5/8	6-7/8	2-7/8	35	8-1/2	134	125
PVM(I/X)2-120	3	1.15	3	208-230/460	182TC	1-1/4	1-1/4	18-1/2	13-5/8	6-7/8	2-7/8	35	8-1/2	115	115
PVM(I/X)2-130	3	1.15	1	115/208-230	182TC	1-1/4	1-1/4	19-1/8	12-1/4	6-7/8	2-3/4	34-1/4	8-1/2	135	126
PVM(I/X)2-130	3	1.15	3	208-230/460	182TC	1-1/4	1-1/4	19-1/8	10-1/4	6-7/8	2-7/8	32-1/4	8-1/2	116	116
PVM(I/X)2-140	5	1.15	1	208-230	213TCZ	1-1/4	1-1/4	19-7/8	15-1/4	8	3-3/8	38-1/2	10-5/8	168	142
PVM(I/X)2-140	5	1.15	3	208-230/460	184TC	1-1/4	1-1/4	19-7/8	13-5/8	6-7/8	2-7/8	36-3/8	8-1/2	141	138
PVM(I/X)2-150	5	1.15	1	208-230	213TCZ	1-1/4	1-1/4	20-5/8	15-1/4	8	3-3/8	39-1/4	10-5/8	169	143
PVM(I/X)2-150	5	1.15	3	208-230/460	184TC	1-1/4	1-1/4	20-5/8	15-1/4	8	3-3/8	39-1/4	10-5/8	142	139
PVM(I/X)2-160	5	1.15	1	208-230	213TCZ	1-1/4	1-1/4	21-1/4	15-1/4	8	3-3/8	40	10-5/8	170	144
PVM(I/X)2-160	5	1.15	3	208-230/460	184TC	1-1/4	1-1/4	21-1/4	13-5/8	6-7/8	2-7/8	37-7/8	8-1/2	143	140
PVM(I/X)2-170	5	1.15	1	208-230	213TCZ	1-1/4	1-1/4	22	15-1/4	8	3-3/8	40-5/8	10-5/8	171	145
PVM(I/X)2-170	5	1.15	3	208-230/460	184TC	1-1/4	1-1/4	22	13-5/8	6-7/8	2-7/8	38-5/8	8-1/2	144	141
PVM(I/X)2-180	5	1.15	1	208-230	213TCZ	1-1/4	1-1/4	22-3/4	15-1/4	8	3-3/8	41-3/8	10-5/8	172	146
PVM(I/X)2-180	5	1.15	3	208-230/460	184TC	1-1/4	1-1/4	22-3/4	15-1/4	8	3-3/8	41-3/8	10-5/8	145	142

* Measurements represent the largest number possible for each model using standard efficiency motors.

† Includes PMVI models constructed of 304 Stainless Steel and PVMX models constructed of 316 Stainless Steel.

Performance Curves – PVM (I/X) 4 Series

Nominal RPM: 3450
Based on Fresh Water @ 68 F.
Maximum Working Pressure: 360 PSI

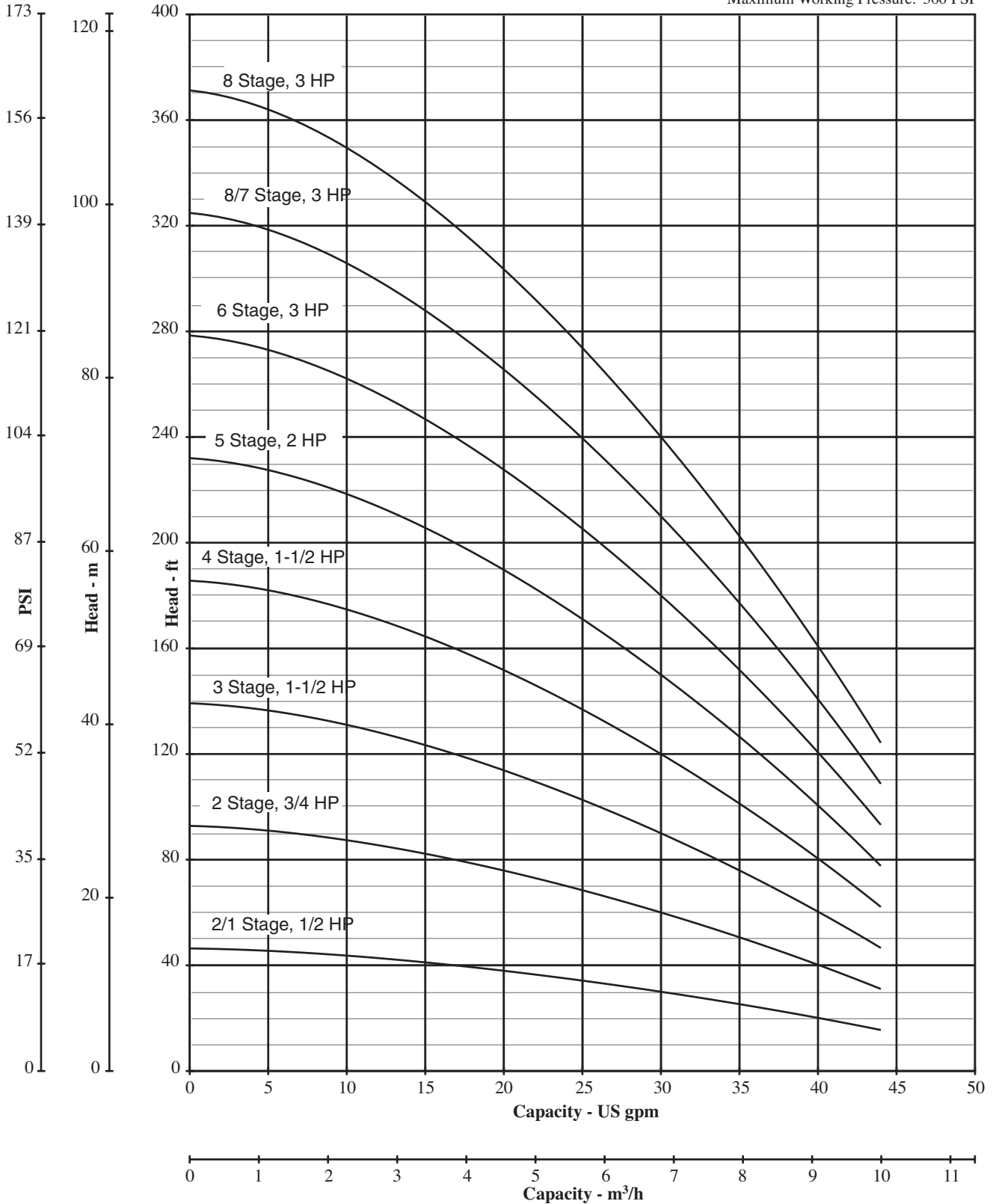

Performance Curves – PVM (I/X) 4 Series

Nominal RPM: 3450
Based on Fresh Water @ 68 F.
Maximum Working Pressure: 360 PSI

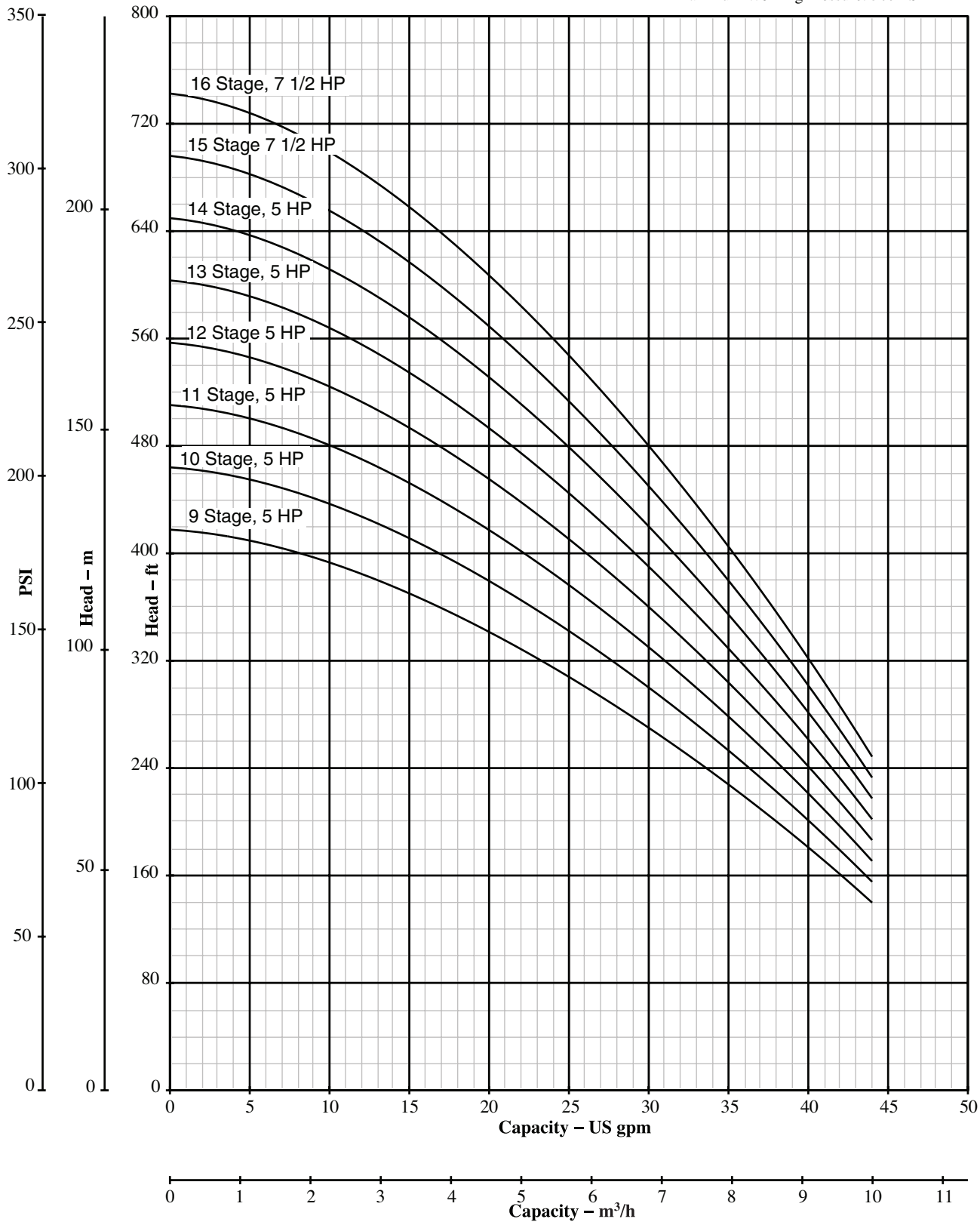

Single Stage Performance Data – PVM (I/X) 4 Series

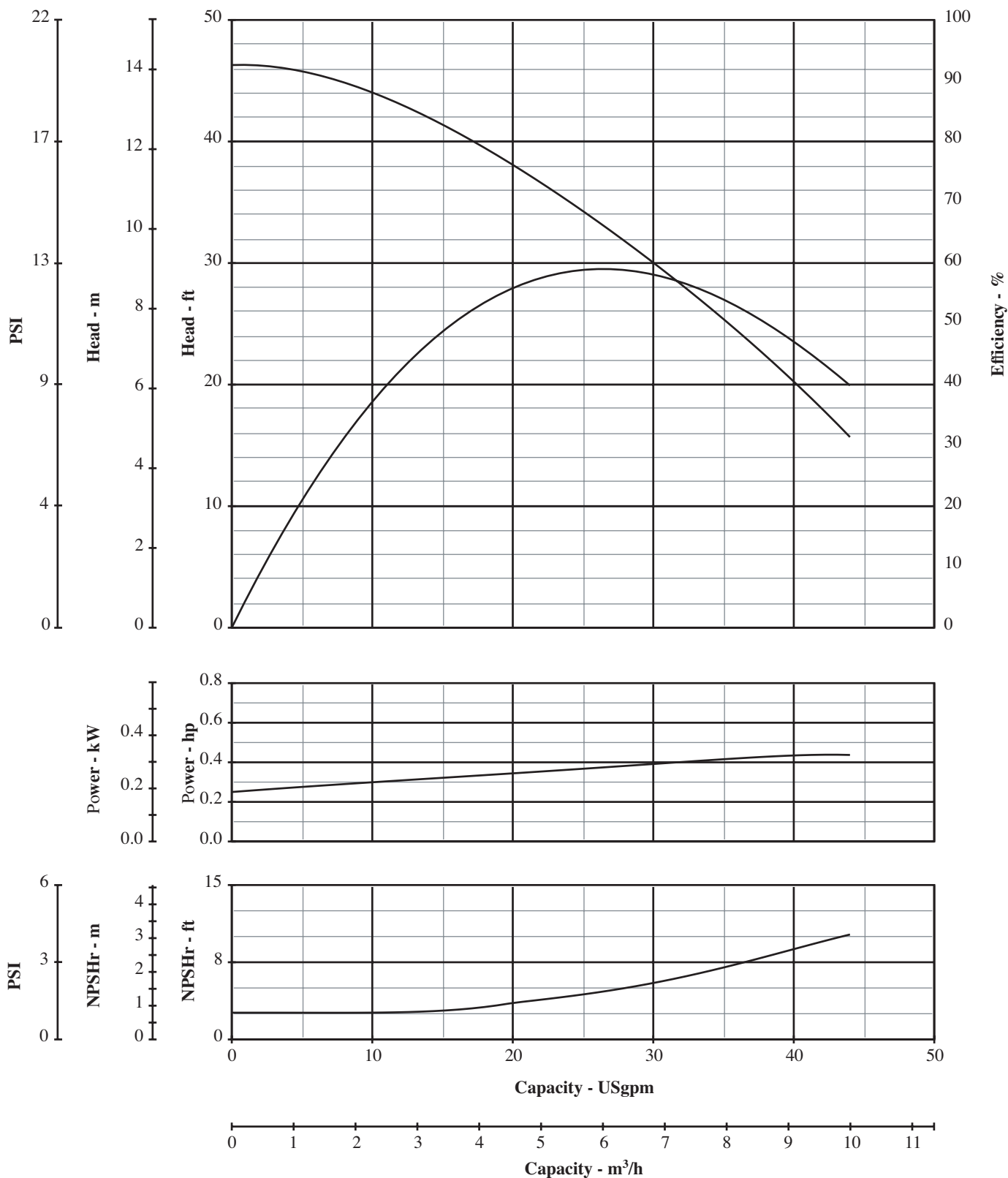

Cast Iron Construction

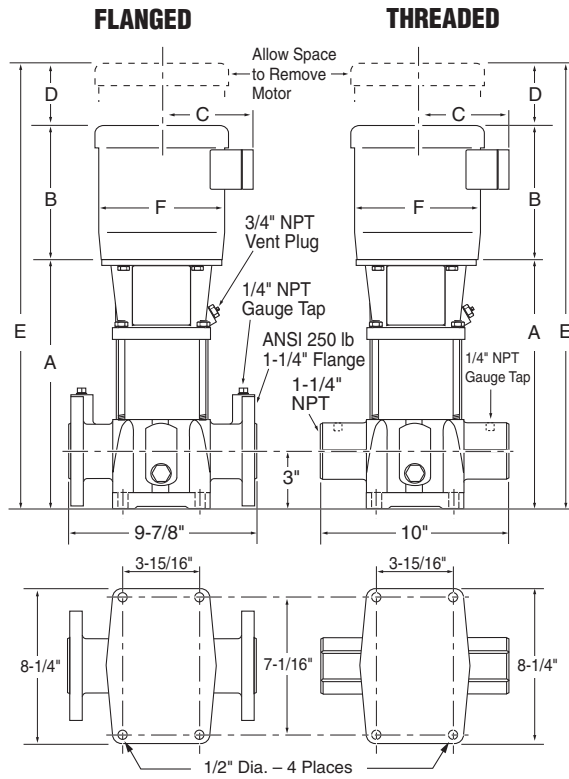
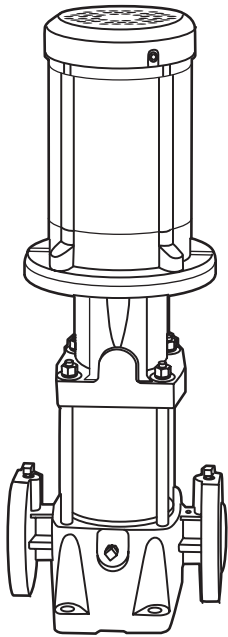

Technical Information

MINIMUM PUMPING RATES: 3 GPM

FLOW RANGE: 3 – 40 GPM

MINIMUM SUCTION PIPE SIZES:
1-1/4" Nominal Diameter, Schedule 40 Pipe

MAXIMUM INLET PRESSURE:

20/1 - 20 – 90 PSI
30 - 80/7 – 145 PSI

80 - 160 – 220 PSI

MAXIMUM AMBIENT TEMPERATURE: 104° F

LIQUID TEMPERATURE RANGE: +5° F to +250° F

MOTOR OPTIONS: TEFC or ODP

CONSTRUCTION MATERIALS: See Page 16.

1-1/4" ANSI. 250 lb. 4-Bolt Flange

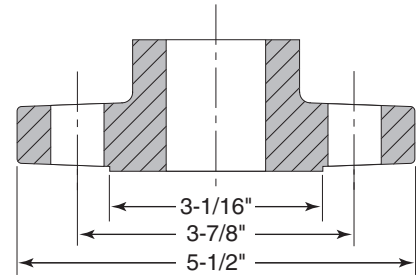

Dimensions and Specifications – PVM 4 Series

1/2 thru 2 HP

Model Number	HP	Motor S.F.	Ph	Volts	Frame Size	Disc. Size	Suc. Size	Dimension in Inches*						TEFC Wt.	ODP Wt.
								A	B	C	D	E	F		
PVM4-20/1	0.5	1.25	1	115/208-230	56C	1-1/4	1-1/4	11-3/8	9-1/4	4-7/8	2	22-5/8	6	79	77
PVM4-20/1	0.5	1.25	3	208-230/460	56C	1-1/4	1-1/4	11-3/8	9-1/4	4-7/8	2	22-5/8	6	76	74
PVM4-20	0.75	1.25	1	115/208-230	56C	1-1/4	1-1/4	11-3/8	9-7/8	4-7/8	2	23-2/8	6	83	85
PVM4-20	0.75	1.25	3	208-230/460	56C	1-1/4	1-1/4	11-3/8	9-1/4	4-7/8	2	22-5/8	6	78	77
PVM4-30	1.5	1.25	1	115/208-230	56C	1-1/4	1-1/4	12-3/8	11-1/8	5-1/4	2	25-5/8	7-1/8	94	87
PVM4-30	1.5	1.15	3	208-230/460	56C	1-1/4	1-1/4	12-3/8	9-1/4	4-7/8	2	23-3/4	6	78	81
PVM4-40	1.5	1.25	1	115/208-230	56C	1-1/4	1-1/4	13-1/2	11-1/8	5-5/8	2	26-5/8	7-1/8	101	96
PVM4-40	1.5	1.15	3	208-230/460	56C	1-1/4	1-1/4	13-1/2	10-1/8	5-3/4	2-1/8	25-3/4	7-1/4	90	89
PVM4-50	2	1.15	1	208-230	56C	1-1/4	1-1/4	14-1/2	12	5-5/8	2	28-5/8	7-1/8	108	101
PVM4-50	2	1.15	3	208-230/460	56C	1-1/4	1-1/4	14-1/2	11-1/8	5-3/4	2-1/8	27-3/4	7-1/4	98	92

* Measurements represent the largest number possible for each model using standard efficiency motors.

Cast Iron Construction

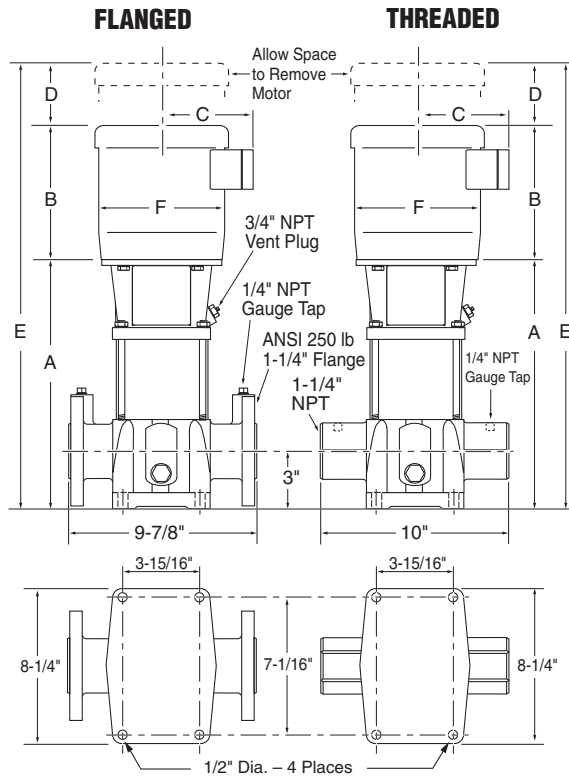
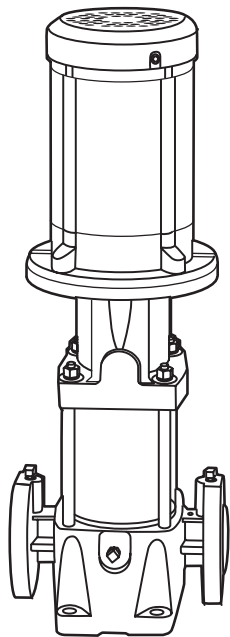

Technical Information

- MINIMUM PUMPING RATES:** 3 GPM
- FLOW RANGE:** 3 – 40 GPM
- MINIMUM SUCTION PIPE SIZES:**
1-1/4" Nominal Diameter, Schedule 40 Pipe
- MAXIMUM INLET PRESSURE:**
20/1 - 20 – 90 PSI
30 - 80/7 – 145 PSI
80 - 160 – 220 PSI
- MAXIMUM AMBIENT TEMPERATURE:** 104° F
- LIQUID TEMPERATURE RANGE:** +5° F to +250° F
- MOTOR OPTIONS:** TEFC or ODP
- CONSTRUCTION MATERIALS:** See Page 16.
1-1/4" ANSI, 250 lb. 4-Bolt Flange

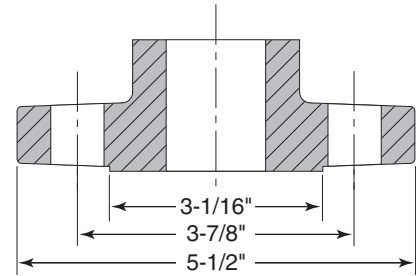

Dimensions and Specifications – PVM 4 Series 3 thru 7-1/2 HP

Model Number	HP	Motor S.F.	Ph	Volts	Frame Size	Disc. Size	Suc. Size	Dimension in Inches*						TEFC Wt.	ODP Wt.
								A	B	C	D	E	F		
PVM4-60	3	1.15	1	208-230	182TC	1-1/4	1-1/4	16	13-5/8	6-7/8	2-3/4	32-3/8	8-1/2	141	132
PVM4-60	3	1.15	3	208-230/460	182TC	1-1/4	1-1/4	16	12-1/4	6-7/8	2-7/8	31-1/8	8-1/2	122	122
PVM4-80/7	3	1.15	1	208-230	182TC	1-1/4	1-1/4	18-1/8	13-5/8	6-7/8	2-3/4	34-1/2	8-1/2	143	134
PVM4-80/7	3	1.15	3	208-230/460	182TC	1-1/4	1-1/4	18-1/8	12-1/4	6-7/8	2-7/8	33-2/8	8-1/2	124	124
PVM4-80	3	1.15	1	208-230	182TC	1-1/4	1-1/4	18-1/8	13-5/8	6-7/8	2-3/4	34-1/2	8-1/2	146	137
PVM4-80	3	1.15	3	208-230/460	182TC	1-1/4	1-1/4	18-1/8	12-1/4	6-7/8	2-7/8	33-1/4	8-1/2	127	127
PVM4-90	5	1.15	1	208-230	213TCZ	1-1/4	1-1/4	19-1/8	15-1/4	8	3-3/8	37-3/4	10-5/8	181	155
PVM4-90	5	1.15	3	208-230/460	184TC	1-1/4	1-1/4	19-1/8	13-5/8	6-7/8	2-7/8	35-3/4	10-5/8	154	151
PVM4-100	5	1.15	1	208-230	213TCZ	1-1/4	1-1/4	20-1/4	15-1/4	8	3-3/8	38-7/8	10-5/8	183	157
PVM4-100	5	1.15	3	208-230/460	184TC	1-1/4	1-1/4	20-1/4	13-5/8	6-7/8	2-7/8	36-3/4	8-1/2	156	153
PVM4-110	5	1.15	1	208-230	213TCZ	1-1/4	1-1/4	21-1/4	15-1/4	8	3-3/8	39-7/8	10-5/8	184	158
PVM4-110	5	1.15	3	208-230/460	184TC	1-1/4	1-1/4	21-1/4	13-5/8	6-7/8	2-7/8	37-7/8	10-5/8	157	154
PVM4-120	5	1.15	1	208-230	213TCZ	1-1/4	1-1/4	22-3/8	15-1/4	8	3-3/8	41	10-5/8	186	160
PVM4-120	5	1.15	3	208-230/460	184TC	1-1/4	1-1/4	22-3/8	13-5/8	6-7/8	2-7/8	38-7/8	8-1/2	159	156
PVM4-130	5	1.15	1	208-230	213TCZ	1-1/4	1-1/4	23-3/8	15-1/4	8	3-3/8	42	10-5/8	187	161
PVM4-130	5	1.15	3	208-230/460	184TC	1-1/4	1-1/4	23-3/8	13-5/8	6-7/8	2-7/8	40	10-5/8	160	157
PVM4-140	5	1.15	1	208-230	213TCZ	1-1/4	1-1/4	24-1/2	15-1/4	8	3-3/8	43-1/8	10-5/8	189	163
PVM4-140	5	1.15	3	208-230/460	184TC	1-1/4	1-1/4	24-1/2	13-5/8	6-7/8	2-7/8	41	8-1/2	162	159
PVM4-150	7.5	1.15	1	208-230	213TCZ	1-1/4	1-1/4	25-1/2	15-1/4	8	3-3/8	44-1/8	10-5/8	171	198
PVM4-150	7.5	1.15	3	208-230/460	213TCZ	1-1/4	1-1/4	25-1/2	12	7-7/8	3-3/8	41	10-5/8	189	178
PVM4-160	7.5	1.15	1	208-230	213TCZ	1-1/4	1-1/4	26-5/8	15-1/4	8	3-3/8	45-1/4	10-5/8	172	199
PVM4-160	7.5	1.15	3	208-230/460	213TCZ	1-1/4	1-1/4	26-5/8	15-1/4	7-7/8	3-3/8	45-1/4	10-3/8	190	179

* Measurements represent the largest number possible for each model using standard efficiency motors.

PVM (I/X) 4 SERIES

304 SS and 316 SS Construction

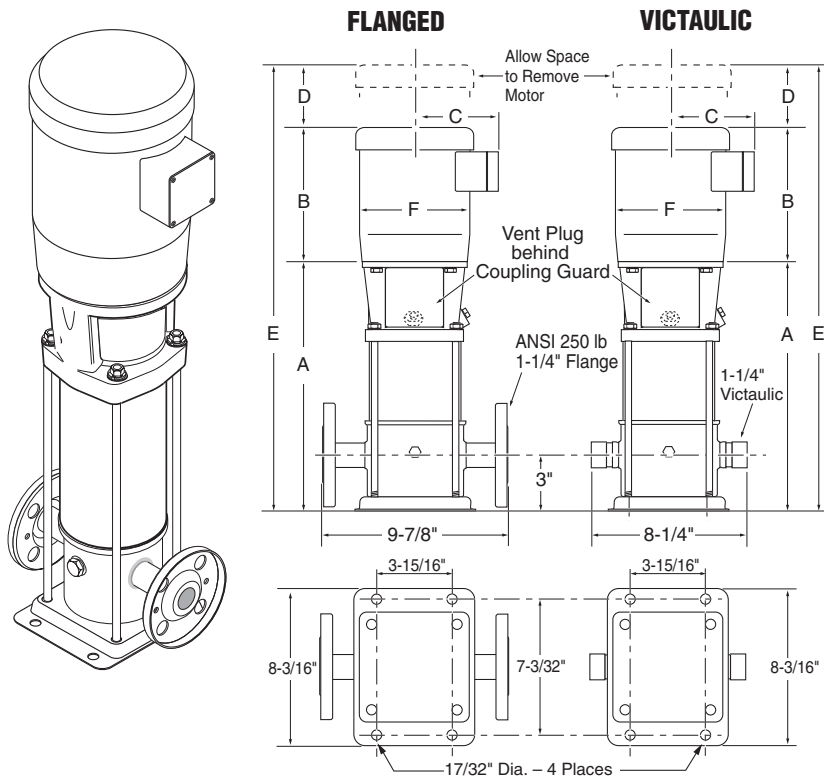

Technical Information

- MINIMUM PUMPING RATES:** 3 GPM
- FLOW RANGE:** 3 – 40 GPM
- MINIMUM SUCTION PIPE SIZES:**
1-1/4" Nominal Diameter, Schedule 40 Pipe
- MAXIMUM INLET PRESSURE:**
20/1 - 20 – 90 PSI
30 - 80/7 – 145 PSI
80 - 160 – 220 PSI
- MAXIMUM AMBIENT TEMPERATURE:** 104° F
- LIQUID TEMPERATURE RANGE:** +5° F to +250° F
- MOTOR OPTIONS:** TEFC or ODP
- CONSTRUCTION MATERIALS:** See Page 16.

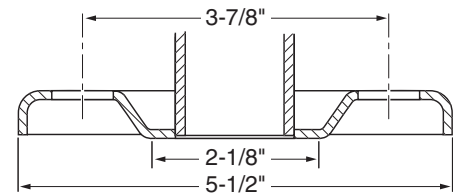

Dimensions and Specifications – PVM (I/X) 4 Series†

1/2 thru 2 HP

Model Number†	HP	Motor S.F.	Ph	Volts	Frame Size	Disc. Size	Suc. Size	Dimension in Inches*						TEFC Wt.	ODP Wt.
								A	B	C	D	E	F		
PVM(I/X)4-20/1	0.5	1.25	1	115/208-230	56C	1-1/4	1-1/4	11-3/4	9-1/4	4-7/8	2	23	6	61	59
PVM(I/X)4-20/1	0.5	1.25	3	208-230/460	56C	1-1/4	1-1/4	11-3/4	9-1/4	4-7/8	2	23	6	58	56
PVM(I/X)4-20	0.75	1.25	1	115/208-230	56C	1-1/4	1-1/4	11-3/4	9-7/8	4-7/8	2	23-5/8	6	69	71
PVM(I/X)4-20	0.75	1.25	3	208-230/460	56C	1-1/4	1-1/4	11-3/4	9-7/8	4-7/8	2	23-5/8	6	64	63
PVM(I/X)4-30	1.5	1.25	1	115/208-230	56C	1-1/4	1-1/4	12-3/4	11-1/8	5-1/4	2	26	7-1/8	85	78
PVM(I/X)4-30	1.5	1.15	3	208-230/460	56C	1-1/4	1-1/4	12-3/4	11-1/8	5-1/4	2	26	7-1/8	69	72
PVM(I/X)4-40	1.5	1.25	1	115/208-230	56C	1-1/4	1-1/4	13-7/8	11-1/8	5-3/4	2-1/8	27	7-1/4	92	87
PVM(I/X)4-40	1.5	1.15	3	208-230/460	56C	1-1/4	1-1/4	13-7/8	11-1/8	5-3/4	2-1/8	27	7-1/4	81	80
PVM(I/X)4-50	2	1.15	1	208-230	56C	1-1/4	1-1/4	14-7/8	12	5-3/4	2-1/8	29	7-1/4	99	92
PVM(I/X)4-50	2	1.15	3	208-230/460	56C	1-1/4	1-1/4	14-7/8	12	5-3/4	2-1/8	29	7-1/4	89	83

* Measurements represent the largest number possible for each model using standard efficiency motors.

† Includes PMVI models constructed of 304 Stainless Steel and PVMX models constructed of 316 Stainless Steel.

PVM (I/X) 4 SERIES

304 SS and 316 SS Construction

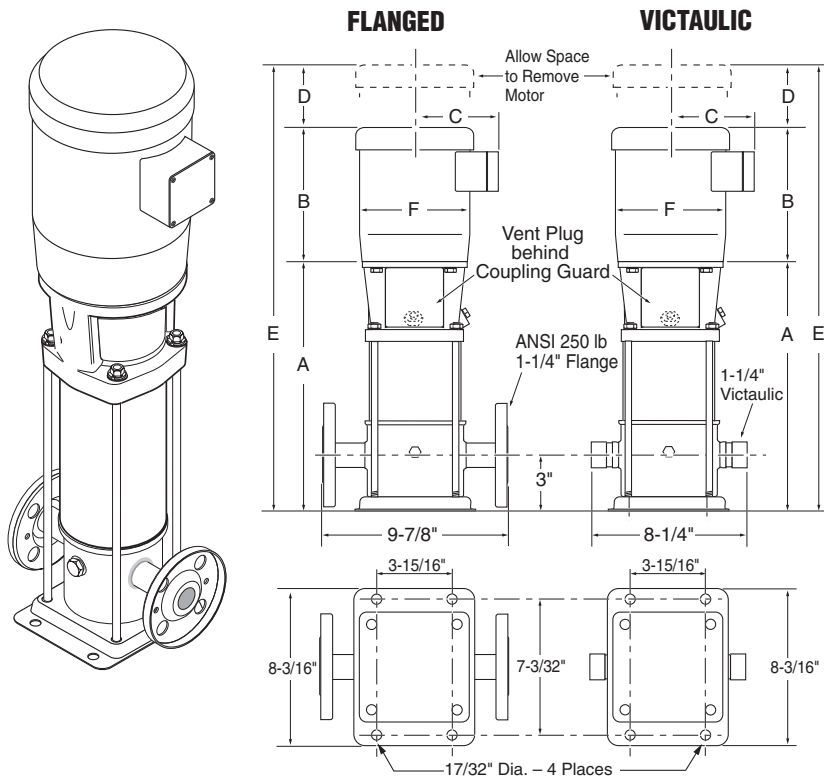

Technical Information

- MINIMUM PUMPING RATES:** 3 GPM
- FLOW RANGE:** 3 – 40 GPM
- MINIMUM SUCTION PIPE SIZES:**
1-1/4" Nominal Diameter, Schedule 40 Pipe
- MAXIMUM INLET PRESSURE:**
20/1 - 20 – 90 PSI
30 - 80/7 – 145 PSI
80 - 160 – 220 PSI
- MAXIMUM AMBIENT TEMPERATURE:** 104° F
- LIQUID TEMPERATURE RANGE:** +5° F to +250° F
- MOTOR OPTIONS:** TEFC or ODP
- CONSTRUCTION MATERIALS:** See Page 16.

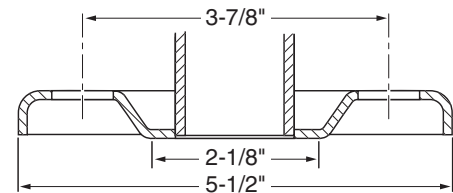

Dimensions and Specifications – PVM (I/X) 4 Series†

3 thru 7-1/2 HP

Model Number†	HP	Motor S.F.	Ph	Volts	Frame Size	Disc. Size	Suc. Size	Dimension in Inches*						TEFC Wt.	ODP Wt.
								A	B	C	D	E	F		
PVM(I/X)4-60	3	1.15	1	208-230	182TC	1-1/4	1-1/4	16-3/8	13-5/8	6-7/8	2-7/8	32-7/8	8-1/2	132	123
PVM(I/X)4-60	3	1.15	3	208-230/460	182TC	1-1/4	1-1/4	16-3/8	13-5/8	6-7/8	2-7/8	32-7/8	8-1/2	113	113
PVM(I/X)4-80/7	3	1.15	1	208-230	182TC	1-1/4	1-1/4	18-1/2	13-5/8	6-7/8	2-7/8	35	8-1/2	134	125
PVM(I/X)4-80/7	3	1.15	3	208-230/460	182TC	1-1/4	1-1/4	18-1/2	13-5/8	6-7/8	2-7/8	35	8-1/2	115	115
PVM(I/X)4-80	3	1.15	1	208-230	182TC	1-1/4	1-1/4	18-1/2	13-5/8	6-7/8	2-7/8	35	8-1/2	137	128
PVM(I/X)4-80	3	1.15	3	208-230/460	182TC	1-1/4	1-1/4	18-1/2	13-5/8	6-7/8	2-7/8	35	8-1/2	118	118
PVM4(I/X)-90	5	1.15	1	208-230	213TCZ	1-1/4	1-1/4	19-1/2	15-1/4	8	3-3/8	38-1/8	10-5/8	172	146
PVM4(I/X)-90	5	1.15	3	208-230/460	184TC	1-1/4	1-1/4	19-1/2	13-5/8	6-7/8	2-7/8	36-1/8	10-5/8	145	142
PVM(I/X)4-100	5	1.15	1	208-230	213TCZ	1-1/4	1-1/4	20-5/8	15-1/4	8	3-3/8	39-1/4	10-5/8	174	148
PVM(I/X)4-100	5	1.15	3	208-230/460	184TC	1-1/4	1-1/4	20-5/8	15-1/4	8	3-3/8	39-1/4	10-5/8	147	144
PVM4(I/X)-110	5	1.15	1	208-230	213TCZ	1-1/4	1-1/4	21-5/8	15-1/4	8	3-3/8	40-1/4	10-5/8	175	149
PVM4(I/X)-110	5	1.15	3	208-230/460	184TC	1-1/4	1-1/4	21-5/8	13-5/8	6-7/8	2-7/8	38-1/4	10-5/8	148	145
PVM(I/X)4-120	5	1.15	1	208-230	213TCZ	1-1/4	1-1/4	22-3/4	15-1/4	8	3-3/8	41-3/8	10-5/8	177	151
PVM(I/X)4-120	5	1.15	3	208-230/460	184TC	1-1/4	1-1/4	22-3/4	15-1/4	8	3-3/8	41-3/8	10-5/8	150	147
PVM4(I/X)-130	5	1.15	1	208-230	213TCZ	1-1/4	1-1/4	23-3/4	15-1/4	8	3-3/8	42-3/8	10-5/8	178	152
PVM4(I/X)-130	5	1.15	3	208-230/460	184TC	1-1/4	1-1/4	23-3/4	13-5/8	6-7/8	2-7/8	40-3/8	10-5/8	151	148
PVM(I/X)4-140	5	1.15	1	208-230	213TCZ	1-1/4	1-1/4	24-7/8	15-1/4	8	3-3/8	43-1/2	10-5/8	180	154
PVM(I/X)4-140	5	1.15	3	208-230/460	184TC	1-1/4	1-1/4	24-7/8	15-1/4	8	3-3/8	43-1/2	10-5/8	153	150
PVM4(I/X)-150	7.5	1.15	1	208-230	213TCZ	1-1/4	1-1/4	25-7/8	15-1/4	8	3-3/8	44-1/2	10-5/8	162	189
PVM4(I/X)-150	7.5	1.15	3	208-230/460	213TCZ	1-1/4	1-1/4	25-7/8	12	7-7/8	3-3/8	41-3/8	10-5/8	180	169
PVM(I/X)4-160	7.5	1.15	1	208-230	213TCZ	1-1/4	1-1/4	27	15-1/4	8	3-3/8	45-3/8	10-5/8	163	190
PVM(I/X)4-160	7.5	1.15	3	208-230/460	213TCZ	1-1/4	1-1/4	27	15-1/4	8	3-3/8	45-3/8	10-5/8	181	170

* Measurements represent the largest number possible for each model using standard efficiency motors.

† Includes PMVI models constructed of 304 Stainless Steel and PVMX models constructed of 316 Stainless Steel.

Construction Materials

Description	Cast Iron	304 Stainless Steel	316 Stainless Steel	Optional Accessories
Shaft	AISI 316 SS	AISI 316 SS	AISI 316 SS	
Impellers, Diffuser Chambers, Pump Sleeve, Suction Interconnector, and Shaft Seal Parts	AISI 304 SS	AISI 304 SS	AISI 316 SS	
Suction/discharge Motor bracket	Class 30 Cast Iron	304 SS	316 SS	
Motor Couplings	Class 30 Cast Iron	Class 30 CI or 316 SS	Class 30 CI or 316 SS	
Intermediate Chamber Bearings	Class 30 Cast Iron	Class 30 Cast Iron	Class 30 Cast Iron	
Bearing Ring	Aluminum Oxide Ceramic	Aluminum Oxide Ceramic	Aluminum Oxide Ceramic	
O-Rings	Tungsten Carbide	Tungsten Carbide	Tungsten Carbide	Viton or Buna
Wear Rings	EPDM	EPDM	EPDM	
Sleeve O-Rings	Teflon	Teflon	Teflon	
Shaft Spacers	EPDM	EPDM	EPDM	Viton or Buna
Top Spring	AISI 316 SS	AISI 316 SS	AISI 316 SS	
Coupling Guard	AISI 316 SS	AISI 316 SS	AISI 316 SS	
Staybolts, Nuts & Washers	AISI 302 SS	AISI 302 SS	AISI 302 SS	
Mechanical Seal (High Pressure)	Zinc Plated Steel	Zinc Plated Steel	Zinc Plated Steel	
• Stationary Face	Tungsten Carbide	Tungsten Carbide	Tungsten Carbide	
• Rotating Face	Tungsten Carbide	Tungsten Carbide	Tungsten Carbide	
• O-Rings	EPDM	EPDM	EPDM	Viton or Buna
• Upper and Lower Drivers	AISI 316 SS	AISI 316 SS	AISI 316 SS	
• Spring	AISI 316 SS	AISI 316 SS	AISI 316 SS	

Performance Curves – PVM (IX) 8 Series

Nominal RPM: 3450
Based on Fresh Water @ 68 F
Maximum Working Pressure: 360 PSI

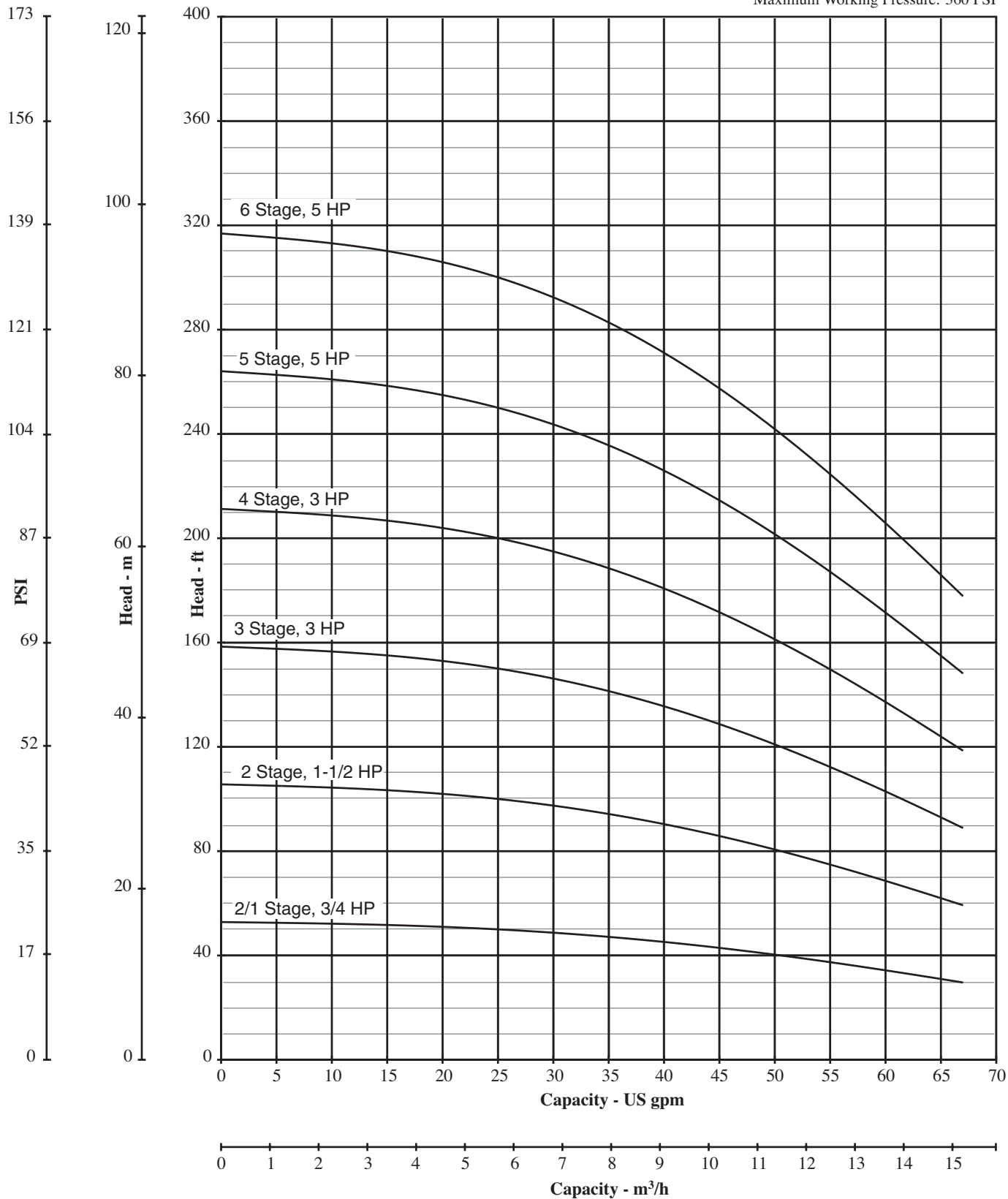

PVM (I/X) 8 SERIES



Performance Curves – PVM (I/X) 8 Series

Nominal RPM: 3450
 Based on Fresh Water @ 68 F.
 Maximum Working Pressure: 360 PSI

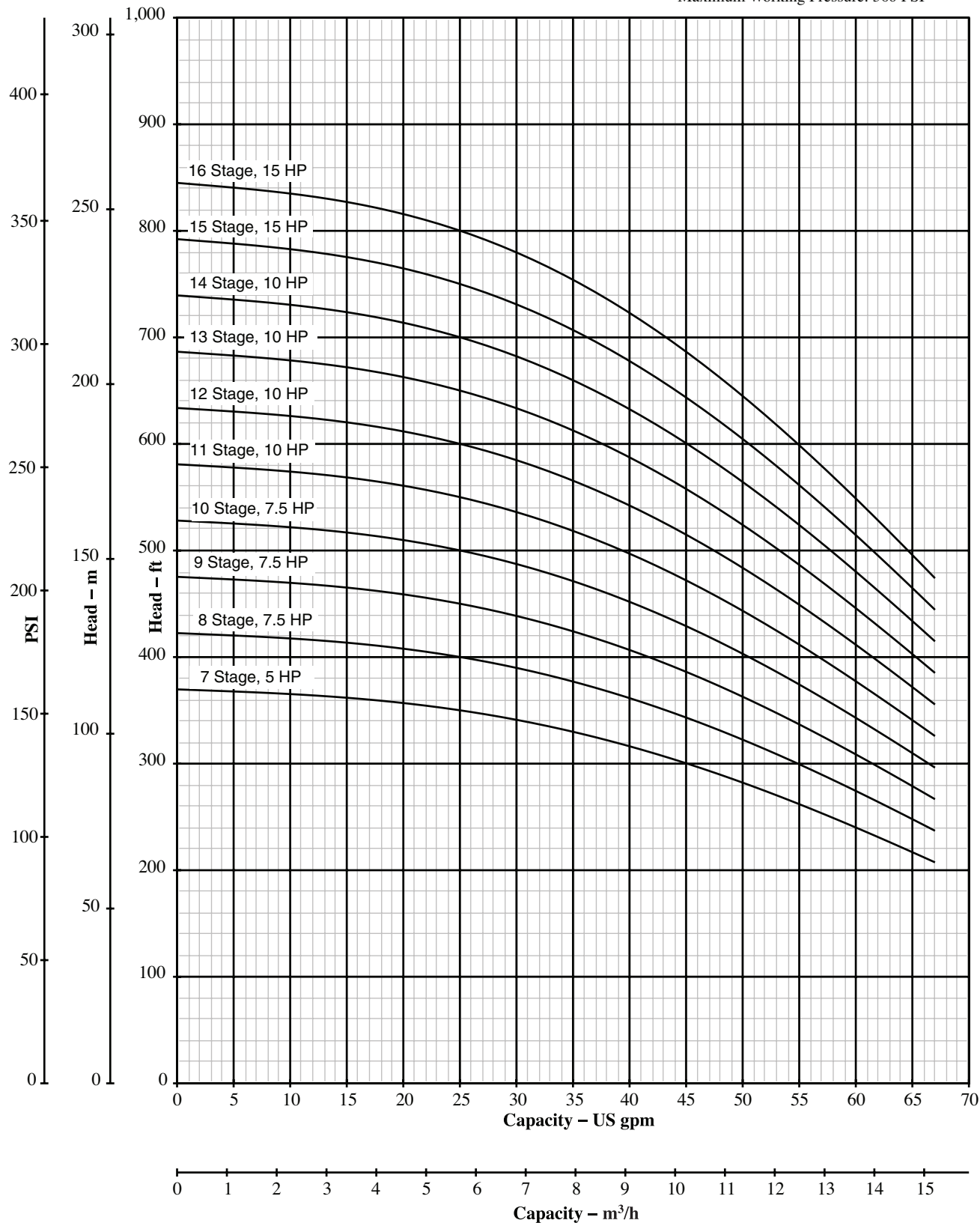

Single Stage Performance Data – PVM (I/X) 8 Series

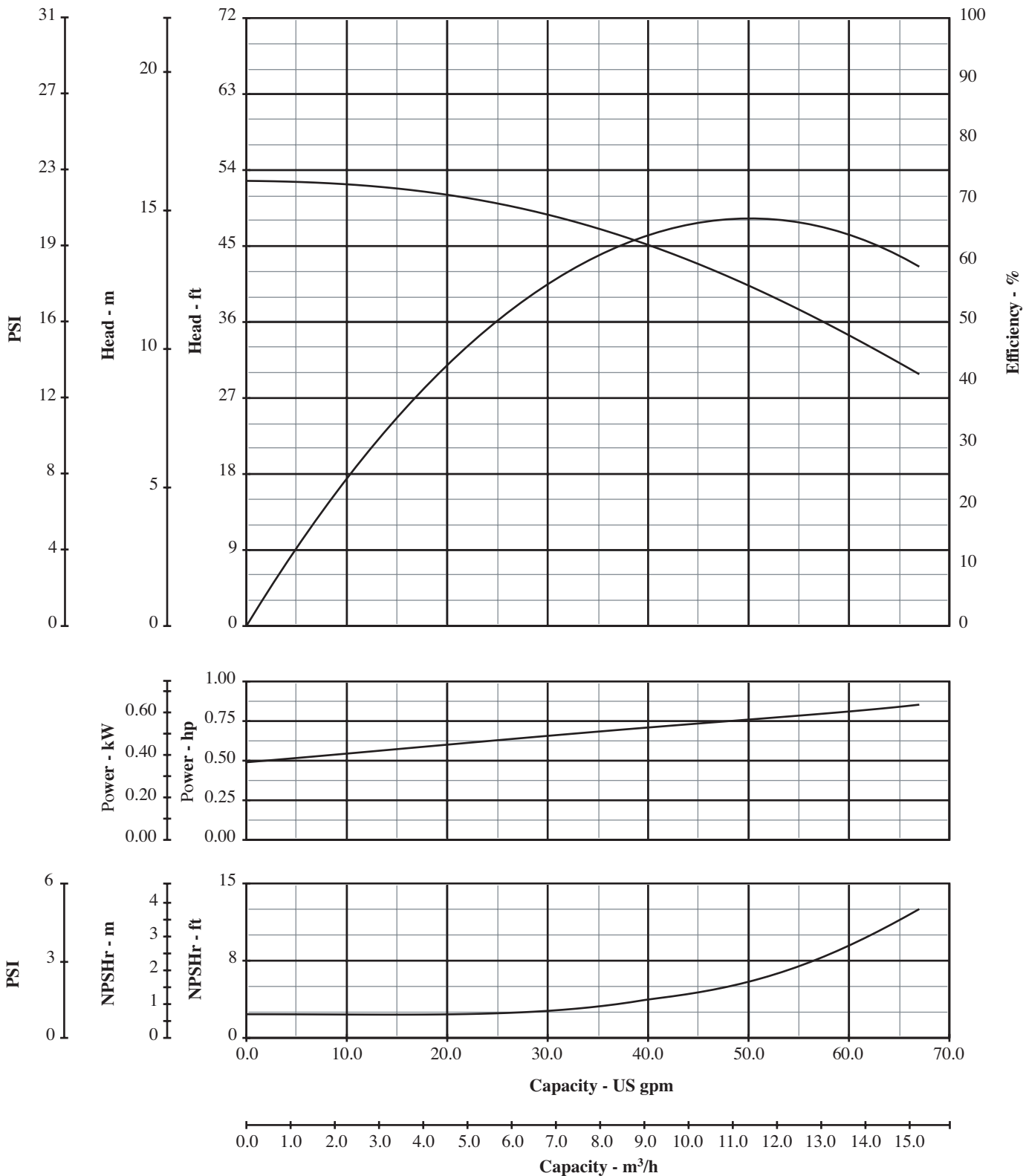

Cast Iron Construction

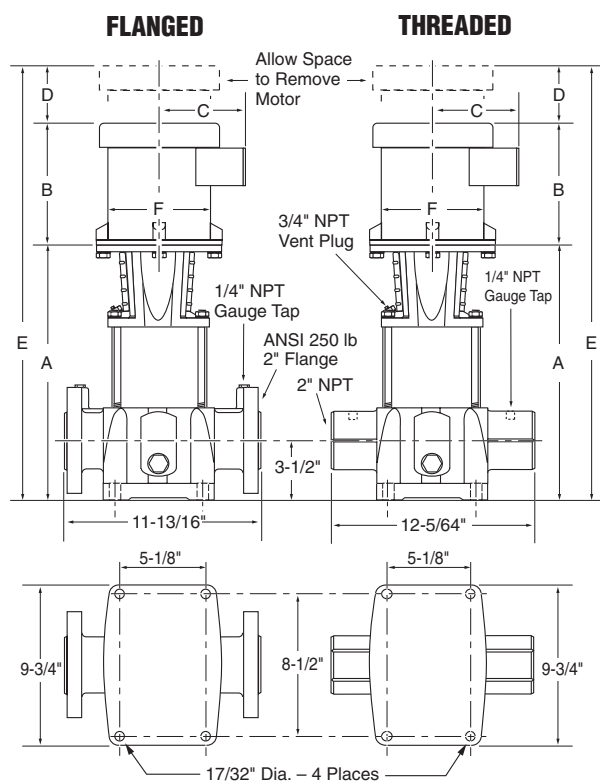
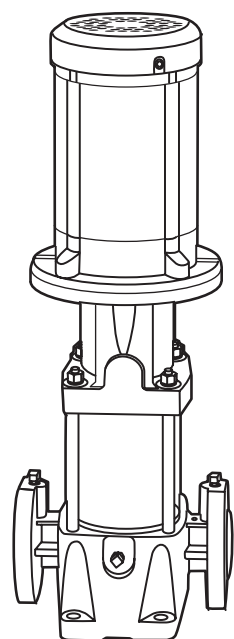

Technical Information

- MINIMUM PUMPING RATES:** 5.3 GPM
- FLOW RANGE:** 5.3 – 65 GPM
- MINIMUM SUCTION PIPE SIZES:**
2" Nominal Diameter, Schedule 40 Pipe
- MAXIMUM INLET PRESSURE:**
20/1 - 40 – 90 PSI
50 - 160 – 145 PSI
- MAXIMUM AMBIENT TEMPERATURE:** 104° F
- LIQUID TEMPERATURE RANGE:** +5° F to +250° F
- MOTOR OPTIONS:** TEFC or ODP
- CONSTRUCTION MATERIALS:** See Page 29.

2" ANSI. 250 lb. 8-Bolt Flange

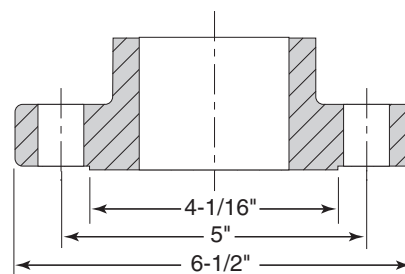

Dimensions and Specifications – PVM 8 Series

3/4 thru 5 HP

Model Number	HP	Motor S.F.	Ph	Volts	Frame Size	Disc. Size	Suc. Size	Dimension in Inches*						TEFC Wt.	ODP Wt.
								A	B	C	D	E	F		
PVM8-20/1	0.75	1.25	1	115/208-230	56C	2	2	15	9-7/8	4-7/8	2	27	6	112	114
PVM8-20/1	0.75	1.25	3	208-230/460	56C	2	2	15	9-1/4	4-7/8	2	26-3/8	6	107	106
PVM8-20	1.5	1.25	1	115/208-230	56C	2	2	15	11-1/8	5-5/8	2	28-1/4	7-1/8	130	125
PVM8-20	1.5	1.15	3	208-230/460	56C	2	2	15	10-1/8	5-3/4	2-1/8	27-1/4	7-1/4	119	118
PVM8-30	3	1.15	1	208-230	182TC	2	2	17-3/4	13-5/8	6-7/8	2-3/4	34-1/8	8-1/2	182	173
PVM8-30	3	1.15	3	208-230/460	182TC	2	2	17-3/4	12-1/4	6-7/8	2-7/8	32-7/8	8-1/2	163	163
PVM8-40	3	1.15	1	208-230	182TC	2	2	18-7/8	13-5/8	6-7/8	2-3/4	35-3/8	8-1/2	184	175
PVM8-40	3	1.15	3	208-230/460	182TC	2	2	18-7/8	12-1/4	6-7/8	2-7/8	34-1/8	8-1/2	165	165
PVM8-50	5	1.15	1	208-230	213TCZ	2	2	20-1/8	15-1/4	8	3-3/8	38-3/4	10-5/8	217	191
PVM8-50	5	1.15	3	208-230/460	184TC	2	2	20-1/8	13-5/8	6-7/8	2-7/8	36-5/8	8-1/2	190	187
PVM8-60	5	1.15	1	208-230	213TCZ	2	2	21-1/4	15-1/4	8	3-3/8	40	10-5/8	221	195
PVM8-60	5	1.15	3	208-230/460	184TC	2	2	21-1/4	13-5/8	6-7/8	2-7/8	37-7/8	8-1/2	194	191
PVM8-70	5	1.15	1	208-230	213TCZ	2	2	21-1/4	15-1/4	8	3-3/8	40	10-5/8	224	198
PVM8-70	5	1.15	3	208-230/460	184TC	2	2	21-1/4	15-1/4	7-7/8	3-3/8	40	10-5/8	197	194

* Measurements represent the largest number possible for each model using standard efficiency motors.

Cast Iron Construction

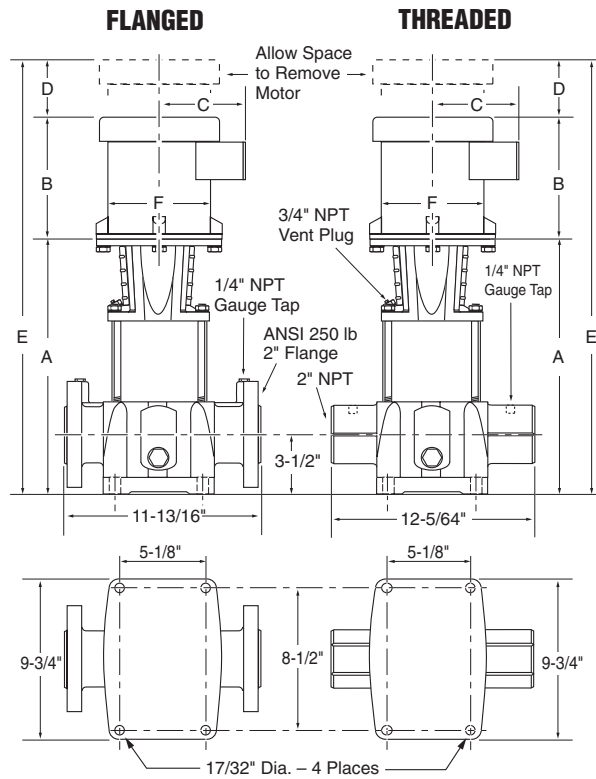
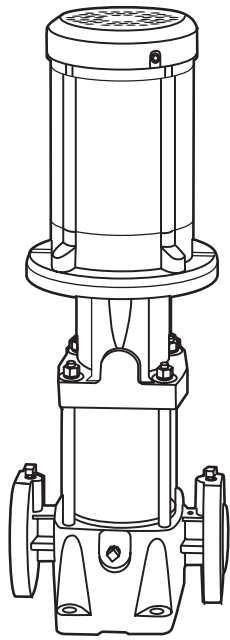

Technical Information

- MINIMUM PUMPING RATES:** 5.3 GPM
- FLOW RANGE:** 5.3 – 65 GPM
- MINIMUM SUCTION PIPE SIZES:**
2" Nominal Diameter, Schedule 40 Pipe
- MAXIMUM INLET PRESSURE:**
20/1 - 40 – 90 PSI
50 - 160 – 145 PSI
- MAXIMUM AMBIENT TEMPERATURE:** 104° F
- LIQUID TEMPERATURE RANGE:** +5° F to +250° F
- MOTOR OPTIONS:** TEFC or ODP
- CONSTRUCTION MATERIALS:** See Page 29.

2" ANSI. 250 lb. 8-Bolt Flange

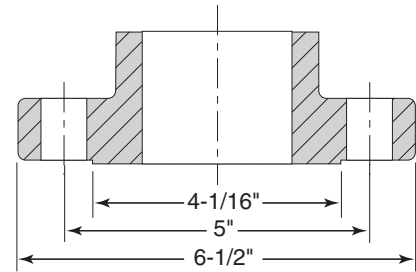

Dimensions and Specifications – PVM 8 Series 7-1/2 thru 15 HP

Model Number	HP	Motor S.F.	Ph	Volts	Frame Size	Disc. Size	Suc. Size	Dimension in Inches*						TEFC Wt.	ODP Wt.
								A	B	C	D	E	F		
PVM8-80	7.5	1.15	1	208-230	213TC	2	2	23-5/8	15-1/4	8	3-3/8	42-1/4	10-5/8	206	223
PVM8-80	7.5	1.15	3	208-230/460	213TC	2	2	23-5/8	15-1/4	7-7/8	3-3/8	42-1/4	10-3/8	224	213
PVM8-90	7.5	1.15	1	208-230	213TC	2	2	26	15-1/4	8	3-3/8	44-5/8	10-5/8	207	234
PVM8-90	7.5	1.15	3	208-230/460	213TC	2	2	26	15-1/4	7 7/8	3-3/8	44-5/8	10-5/8	225	214
PVM8-100	7.5	1.15	1	208-230	213TC	2	2	26	15-1/4	8	3-3/8	44-5/8	10-5/8	208	235
PVM8-100	7.5	1.15	3	208-230/460	213TC	2	2	26	15-1/4	7-7/8	3-3/8	44-5/8	10-3/8	226	215
PVM8-110	10	1.15	1	208-230	215TC	2	2	28-3/8	16-3/8	8-3/4	3-3/8	48-1/8	10-5/8	285	265
PVM8-110	10	1.15	3	208-230/460	215TC	2	2	28-3/8	16-3/8	8	3-3/8	48-1/8	10-5/8	224	269
PVM8-120	10	1.15	1	208-230	215TC	2	2	28-3/8	16-3/8	8-3/4	3-3/8	48-1/8	10-5/8	286	266
PVM8-120	10	1.15	3	208-230/460	215TC	2	2	28-3/8	15-1/4	8	3-3/8	47	10-3/8	225	270
PVM8-130	10	1.15	1	208-230	215TC	2	2	28-3/8	16-3/8	8-3/4	3-3/8	48-1/8	10-5/8	287	267
PVM8-130	10	1.15	3	208-230/460	215TC	2	2	28-3/8	16-3/8	8	3-3/8	48-1/8	10-5/8	226	271
PVM8-140	10	1.15	1	208-230	215TC	2	2	30-3/4	16-3/8	8-3/4	3-3/8	50-1/2	10-5/8	288	268
PVM8-140	10	1.15	3	208-230/460	215TC	2	2	30-3/4	15-1/4	8	3-3/8	49-3/8	10-3/8	227	272
PVM8-150	15	1.15	3	230/460	254TC	2	2	33-5/8	19-5/8	9-1/2	4-1/4	57-1/2	13	354	351
PVM8-160	15	1.15	3	208-230/460	254TC	2	2	33-5/8	19-5/8	9-1/2	4-1/4	57-1/2	13	355	352

* Measurements represent the largest number possible for each model using standard efficiency motors.

PVM (I/X) 8 SERIES

304 SS and 316 SS Construction

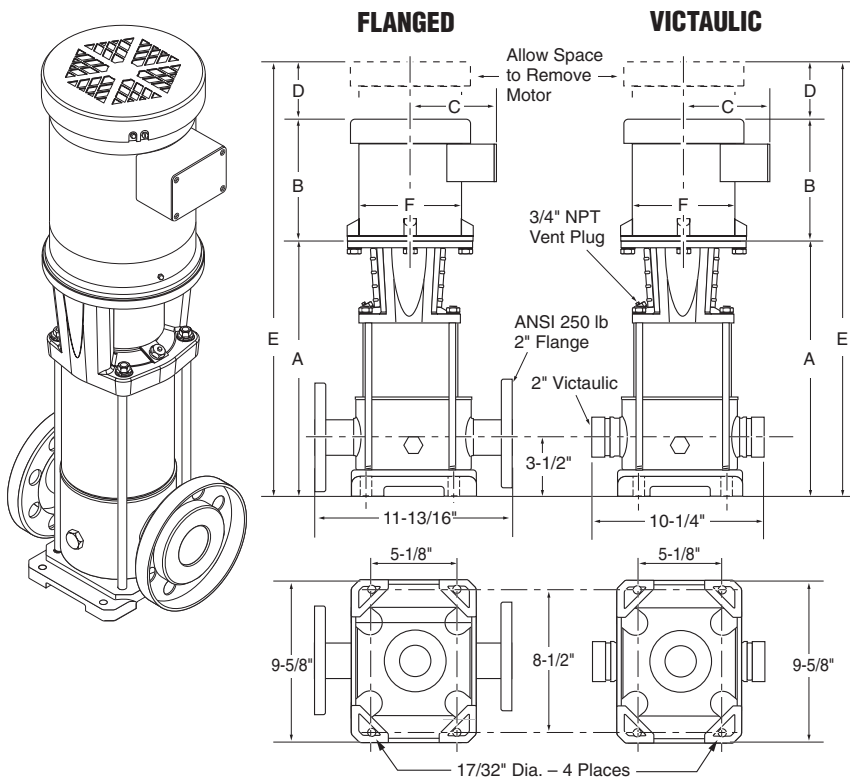

Technical Information

- MINIMUM PUMPING RATES:** 5.3 GPM
- FLOW RANGE:** 5.3 – 65 GPM
- MINIMUM SUCTION PIPE SIZES:**
2" Nominal Diameter, Schedule 40 Pipe
- MAXIMUM INLET PRESSURE:**
20/1 - 40 – 90 PSI
50 - 160 – 145 PSI
- MAXIMUM AMBIENT TEMPERATURE:** 104° F
- LIQUID TEMPERATURE RANGE:** +5° F to +250° F
- MOTOR OPTIONS:** TEFC or ODP
- CONSTRUCTION MATERIALS:** See Page 29.

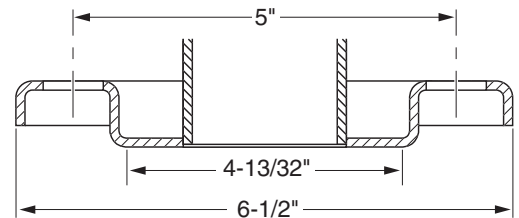

Dimensions and Specifications – PVM (I/X) 8 Series†

3/4 thru 5 HP

Model Number†	HP	Motor S.F.	Ph	Volts	Frame Size	Disc. Size	Suc. Size	Dimension in Inches*						TEFC Wt.	ODP Wt.
								A	B	C	D	E	F		
PVM(I/X)8-20/1	0.75	1.25	1	115/208-230	56C	2	2	15	9-7/8	4-7/8	2	27	6	72	74
PVM(I/X)8-20/1	0.75	1.25	3	208-230/460	56C	2	2	15	9-7/8	4-7/8	2	27	6	67	66
PVM(I/X)8-20	1.5	1.25	1	115/208-230	56C	2	2	15	11-1/8	5-3/4	2-1/8	28-1/4	7-1/4	90	85
PVM(I/X)8-20	1.5	1.15	3	208-230/460	56C	2	2	15	11-1/8	5-3/4	2-1/8	28-1/4	7-1/4	79	78
PVM(I/X)8-30	3	1.15	1	208-230	182TC	2	2	17-3/4	13-5/8	6-7/8	2-7/8	34-1/4	8-1/2	142	133
PVM(I/X)8-30	3	1.15	3	208-230/460	182TC	2	2	17-3/4	13-5/8	6-7/8	2-7/8	34-1/4	8-1/2	123	123
PVM(I/X)8-40	3	1.15	1	208-230	182TC	2	2	18-7/8	13-5/8	6-7/8	2-7/8	35-1/2	8-1/2	144	135
PVM(I/X)8-40	3	1.15	3	208-230/460	182TC	2	2	18-7/8	13-5/8	6-7/8	2-7/8	35-1/2	8-1/2	125	125
PVM(I/X)8-50	5	1.15	1	208-230	213TCZ	2	2	20-1/8	15-1/4	8	3-3/8	38-3/4	10-5/8	177	151
PVM(I/X)8-50	5	1.15	3	208-230/460	184TC	2	2	20-1/8	15-1/4	8	3-3/8	38-3/4	10-5/8	150	147
PVM(I/X)8-60	5	1.15	1	208-230	213TCZ	2	2	21-1/4	15-1/4	8	3-3/8	40	10-5/8	181	155
PVM(I/X)8-60	5	1.15	3	208-230/460	184TC	2	2	21-1/4	15-1/4	8	3-3/8	40	10-5/8	154	151
PVM(I/X)8-70	5	1.15	1	208-230	213TCZ	2	2	21-3/8	15-1/4	8	3-3/8	40	10-5/8	184	158
PVM(I/X)8-70	5	1.15	3	208-230/460	184TC	2	2	21-3/8	15-1/4	7-7/8	3-3/8	40	10-5/8	157	154

* Measurements represent the largest number possible for each model using standard efficiency motors.

† Includes PMVI models constructed of 304 Stainless Steel and PVMX models constructed of 316 Stainless Steel.

PVM (I/X) 8 SERIES

304 SS and 316 SS Construction

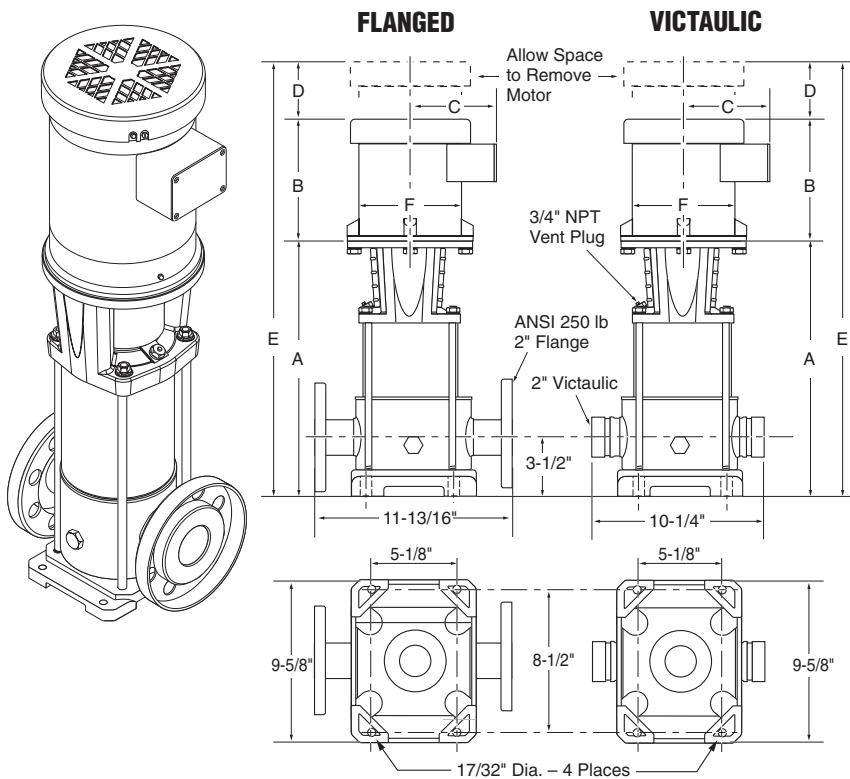

Technical Information

- MINIMUM PUMPING RATES:** 5.3 GPM
- FLOW RANGE:** 5.3 – 65 GPM
- MINIMUM SUCTION PIPE SIZES:**
2" Nominal Diameter, Schedule 40 Pipe
- MAXIMUM INLET PRESSURE:**
20/1 - 40 – 90 PSI
50 - 160 – 145 PSI
- MAXIMUM AMBIENT TEMPERATURE:** 104° F
- LIQUID TEMPERATURE RANGE:** +5° F to +250° F
- MOTOR OPTIONS:** TEFC or ODP
- CONSTRUCTION MATERIALS:** See Page 29.

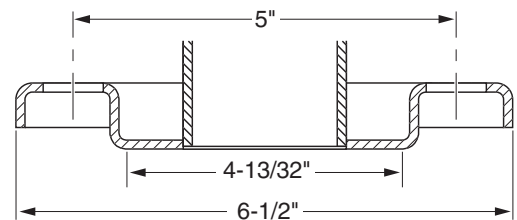

Dimensions and Specifications – PVM (I/X) 8 Series†

7-1/2 thru 15 HP

Model Number†	HP	Motor S.F.	Ph	Volts	Frame Size	Disc. Size	Suc. Size	Dimension in Inches*						TEFC Wt.	ODP Wt.
								A	B	C	D	E	F		
PVM(I/X)8-80	7.5	1.15	1	208-230	213TC	2	2	23-5/8	15-1/4	8	3-3/8	42-1/4	10-5/8	166	193
PVM(I/X)8-80	7.5	1.15	3	208-230/460	213TC	2	2	23-5/8	15-1/4	8	3-3/8	42-1/4	10-5/8	184	173
PVM(I/X)8-90	7.5	1.15	1	208-230	213TC	2	2	26-1/8	15 1/4	8	3-3/8	44-3/4	10-5/8	167	194
PVM(I/X)8-90	7.5	1.15	3	208-230/460	213TC	2	2	26-1/8	151/4	7-7/8	3-3/8	44-3/4	10-5/8	185	174
PVM(I/X)8-100	7.5	1.15	1	208-230	213TC	2	2	26	15-1/4	8	3-3/8	44-5/8	10-5/8	168	195
PVM(I/X)8-100	7.5	1.15	3	208-230/460	213TC	2	2	26	15-1/4	8	3-3/8	44-5/8	10-5/8	186	175
PVM(I/X)8-110	10	1.15	1	208-230	215TC	2	2	28-1/2	16-3/8	8-3/4	3-3/8	48-1/4	10-5/8	245	225
PVM(I/X)8-110	10	1.15	3	208-230/460	215TC	2	2	28-1/2	16-3/8	8	3-3/8	48-1/4	10-5/8	184	229
PVM(I/X)8-120	10	1.15	1	208-230	215TC	2	2	28-3/8	16-1/2	8-3/4	3-3/8	48-1/4	10-5/8	246	226
PVM(I/X)8-120	10	1.15	3	208-230/460	215TC	2	2	28-3/8	16-1/2	8-3/4	3-3/8	48-1/4	10-5/8	185	230
PVM(I/X)8-130	10	1.15	1	208-230	215TC	2	2	28-1/2	16-3/8	8-3/4	3-3/8	48-1/4	10-5/8	247	227
PVM(I/X)8-130	10	1.15	3	208-230/460	215TC	2	2	28-1/2	16-3/8	8	3-3/8	48-1/4	10-5/8	186	231
PVM(I/X)8-140	10	1.15	1	208-230	215TC	2	2	30-3/4	16-3/8	8-3/4	3-3/8	50-1/2	10-5/8	248	228
PVM(I/X)8-140	10	1.15	3	208-230/460	215TC	2	2	30-3/4	16-3/8	8-3/4	3-3/8	50-1/2	10-5/8	187	232
PVM(I/X)8-150	15	1.15	3	230/460	254TC	2	2	33-3/4	19-5/8	9-1/2	4-1/4	57-5/8	13	314	311
PVM(I/X)8-160	15	1.15	3	208-230/460	254TC	2	2	33-5/8	19-5/8	9-1/2	4-1/4	57-1/2	13	315	312

* Measurements represent the largest number possible for each model using standard efficiency motors.

† Includes PMVI models constructed of 304 Stainless Steel and PVMX models constructed of 316 Stainless Steel.

PVM (I/X) 16 SERIES



Performance Curves – PVM (I/X) 16 Series

Nominal RPM: 3450
 Based on Fresh Water @ 68 F
 Maximum Working Pressure: 360 PSI

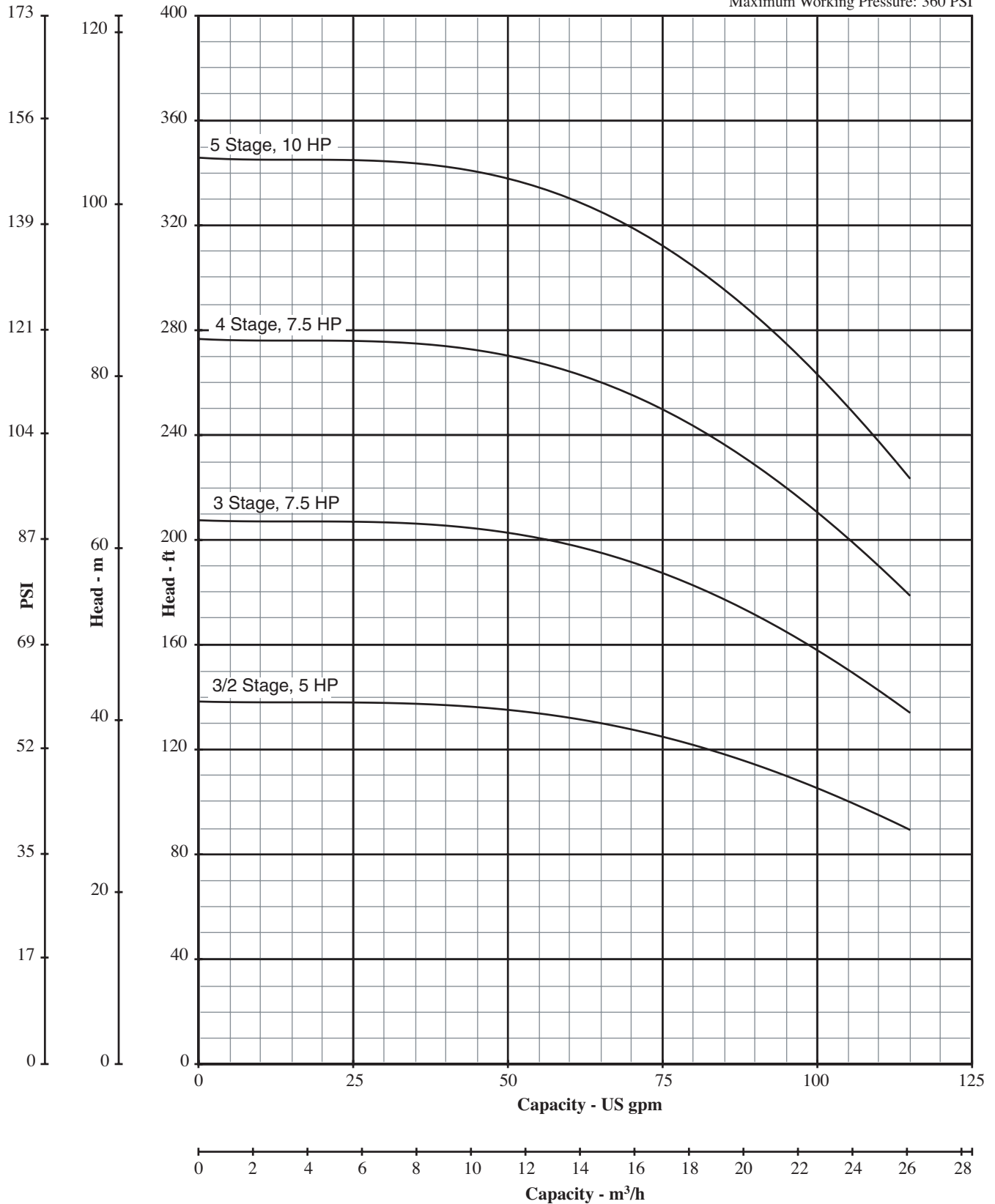

PVM (I/X) 16 SERIES



Performance Curves – PVM (I/X) 16 Series

Nominal RPM: 3450
 Based on Fresh Water @ 68 F.
 Maximum Working Pressure: 360 PSI

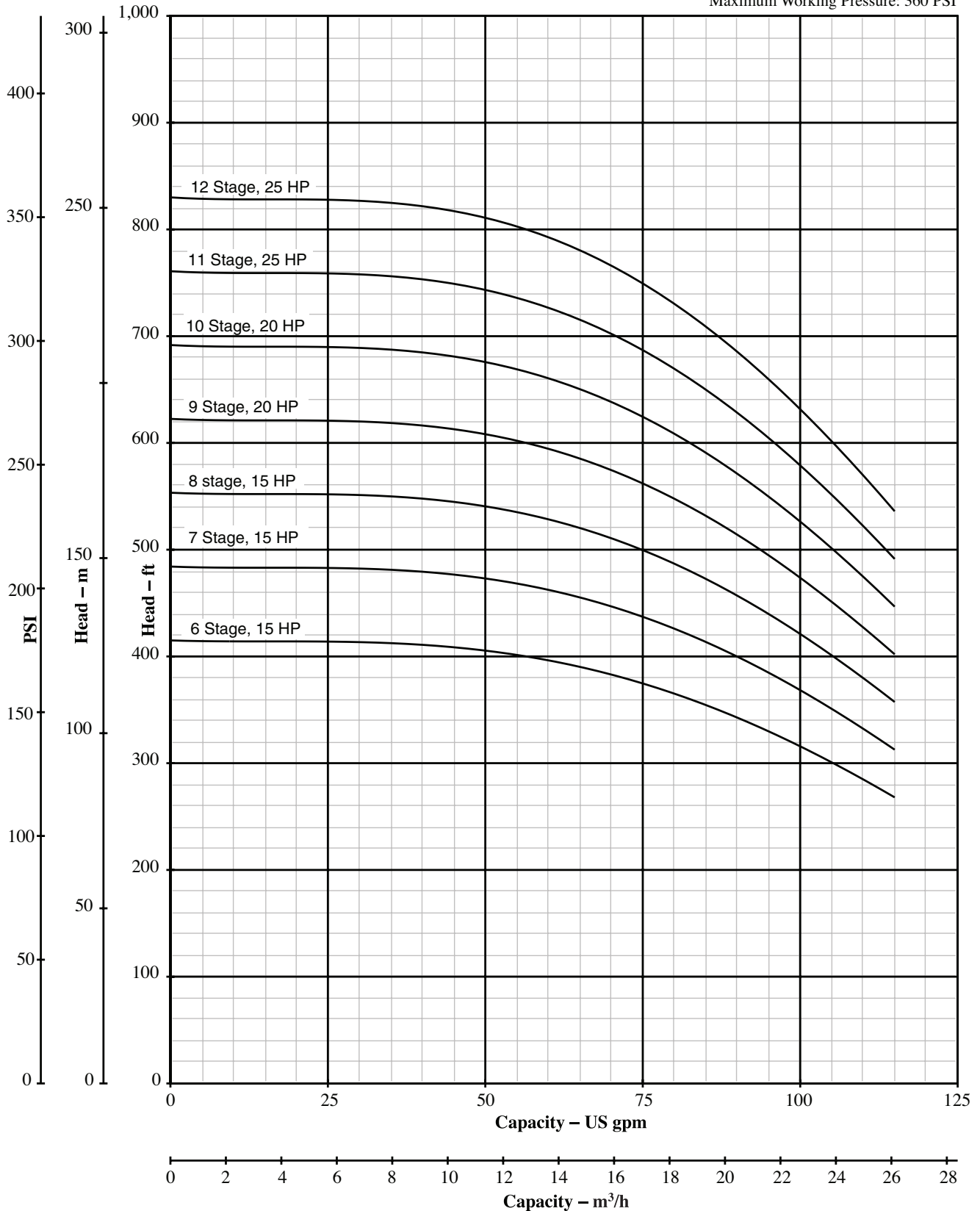

Single Stage Performance Data – PVM (I/X) 16 Series

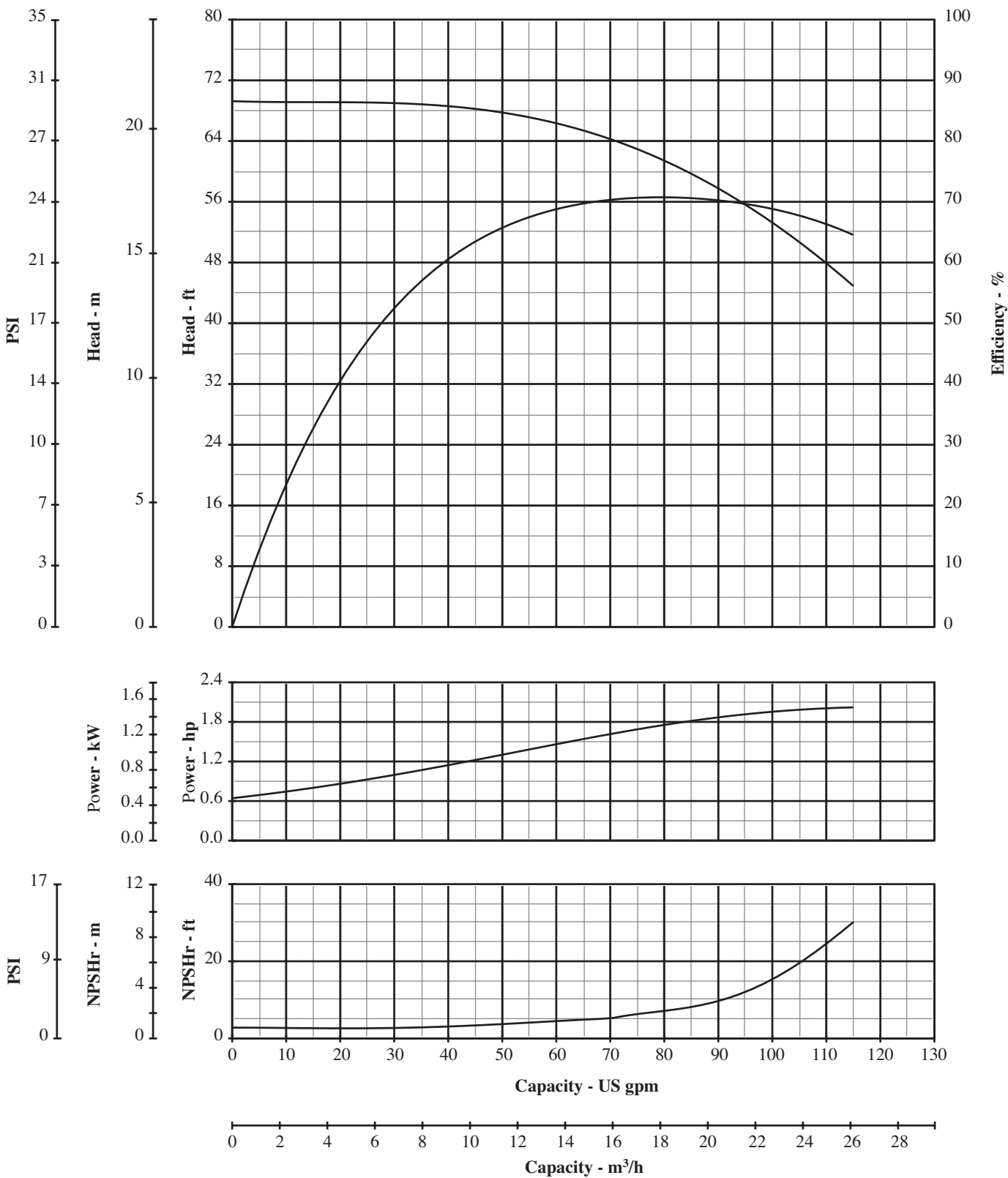

Cast Iron Construction

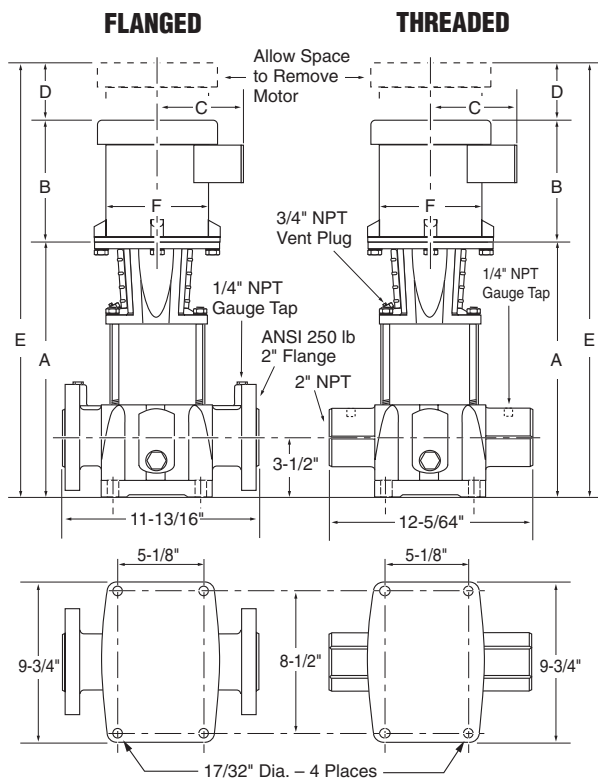
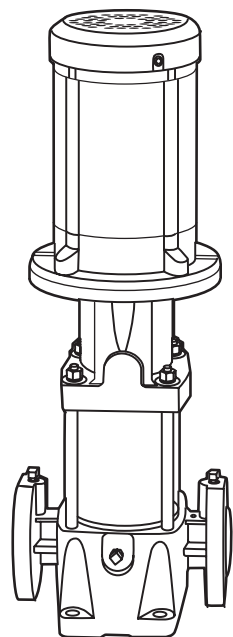

Technical Information

- MINIMUM PUMPING RATES:** 8.5 GPM
- FLOW RANGE:** 8.5 – 115 GPM
- MINIMUM SUCTION PIPE SIZES:**
2" Nominal Diameter, Schedule 40 Pipe
- MAXIMUM INLET PRESSURE:**
30/2 - 30 – 90 PSI
40 - 120 – 145 PSI
- MAXIMUM AMBIENT TEMPERATURE:** 104° F
- LIQUID TEMPERATURE RANGE:** +5° F to +250° F
- MOTOR OPTIONS:** TEFC or ODP
- CONSTRUCTION MATERIALS:** See Page 29.

2" ANSI. 250 lb. 8-Bolt Flange

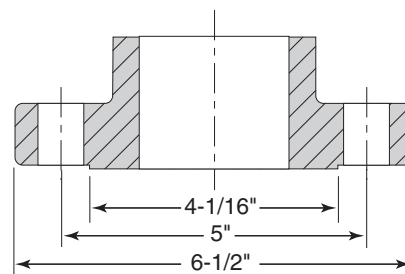

Dimensions and Specifications – PVM 16 Series 5 thru 25 HP

Model Number	HP	Motor S.F.	Ph	Volts	Frame Size	Disc. Size	Suc. Size	Dimension in Inches*						TEFC Wt.	ODP Wt.
								A	B	C	D	E	F		
PVM16-30/2	5	1.15	1	208-230	213TCZ	2	2	19-5/8	15-1/4	8	3-3/8	38-1/4	10-5/8	218	192
PVM16-30/2	5	1.15	3	208-230/460	184TC	2	2	19-5/8	13-5/8	6-7/8	2-7/8	36-1/8	8-1/2	191	188
PVM16-30	7.5	1.15	1	208-230	213TC	2	2	19-5/8	15-1/4	8	3-3/8	38-1/4	10-5/8	200	227
PVM16-30	7.5	1.15	3	208-230/460	213TC	2	2	19-5/8	15-1/4	7-1/2	3-3/8	38-1/4	10-3/8	218	207
PVM16-40	7.5	1.15	1	208-230	213TC	2	2	21-3/8	15-1/4	8	3-3/8	40	10-5/8	200	227
PVM16-40	7.5	1.15	3	208-230/460	213TC	2	2	21-3/8	15-1/4	7-7/8	3-3/8	40	10-3/8	218	207
PVM16-50	10	1.15	1	208-230	215TC	2	2	23-1/8	16-3/8	8-3/4	3-3/8	42-7/8	10-5/8	285	265
PVM16-50	10	1.15	3	208-230/460	215TC	2	2	23-1/8	15-1/4	8	3-3/8	41-3/4	10-3/8	224	269
PVM16-60	15	1.15	3	208-230/460	254TC	2	2	25-3/8	19-5/8	9-1/2	4-1/4	49-1/4	13	344	341
PVM16-70	15	1.15	3	208-230/460	254TC	2	2	27-1/8	19-5/8	9-1/2	4-1/4	51	13	347	344
PVM16-80	15	1.15	3	208-230/460	254TC	2	2	28-7/8	19-5/8	9-1/2	4-1/4	52-7/8	13	349	346
PVM16-90	20	1.15	3	230/460	254TC	2	2	30-1/4	21-3/4	9-1/8	4	56	11-1/2	416	351
PVM16-100	20	1.15	3	230/460	254TC	2	2	32	21-3/4	9-1/8	4	57-3/4	11-1/2	420	355
PVM16-110	25	1.15	3	230/460	284TSC	2	2	33-5/8	21-3/4	9-1/2	3-1/4	58-5/8	13	525	402
PVM16-120	25	1.15	3	230/460	284TSC	2	2	35-3/8	21-3/4	9-1/2	3-1/4	60-3/8	13	533	410

* Measurements represent the largest number possible for each model using standard efficiency motors.

PVM (I/X) 16 SERIES

304 SS and 316 SS Construction

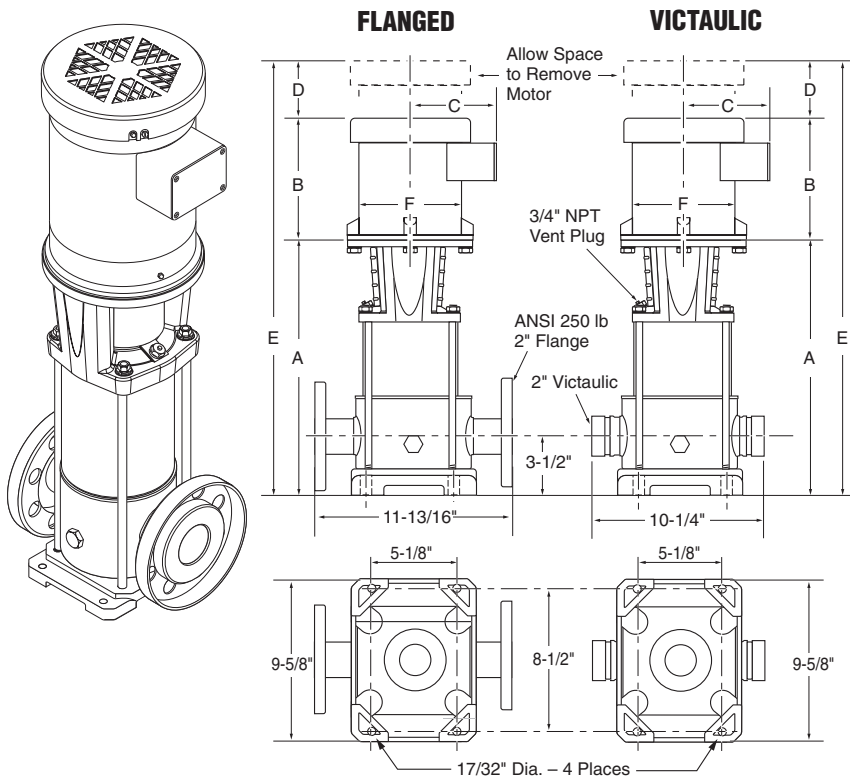

Technical Information

- MINIMUM PUMPING RATES:** 8.5 GPM
- FLOW RANGE:** 8.5 – 115 GPM
- MINIMUM SUCTION PIPE SIZES:**
2" Nominal Diameter, Schedule 40 Pipe
- MAXIMUM INLET PRESSURE:**
30/2 - 30 – 90 PSI
40 - 120 – 145 PSI
- MAXIMUM AMBIENT TEMPERATURE:** 104° F
- LIQUID TEMPERATURE RANGE:** +5° F to +250° F
- MOTOR OPTIONS:** TEFC or ODP
- CONSTRUCTION MATERIALS:** See Page 29.

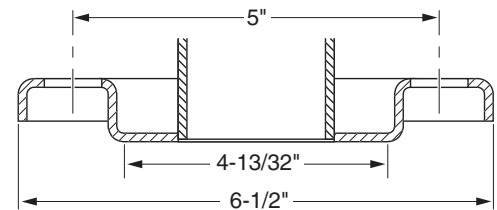

Dimensions and Specifications – PVM (I/X) 16 Series†

5 thru 25 HP

Model Number†	HP	Motor S.F.	Ph	Volts	Frame Size	Disc. Size	Suc. Size	Dimension in Inches*						TEFC Wt.	ODP Wt.
								A	B	C	D	E	F		
PVM(I/X)16-30/2	5	1.15	1	208-230	213TCZ	2	2	19-1/2	15-1/4	8	3-3/8	38-1/4	10-5/8	167	141
PVM(I/X)16-30/2	5	1.15	3	208-230/460	184TC	2	2	19-1/2	15-1/4	8	3-3/8	38-1/4	10-5/8	140	137
PVM(I/X)16-30	7.5	1.15	1	208-230	213TC	2	2	19-1/2	15-1/4	8	3-3/8	38-1/4	10-5/8	153	180
PVM(I/X)16-30	7.5	1.15	3	208-230/460	213TC	2	2	19-1/2	15-1/4	8	3-3/8	38-1/4	10-5/8	171	160
PVM(I/X)16-40	7.5	1.15	1	208-230	213TC	2	2	21-3/8	15-1/4	8	3-3/8	40	10-5/8	156	183
PVM(I/X)16-40	7.5	1.15	3	208-230/460	213TC	2	2	21-3/8	15-1/4	8	3-3/8	40	10-5/8	174	163
PVM(I/X)16-50	10	1.15	1	208-230	215TC	2	2	23-1/8	16-3/8	8-3/4	3-3/8	42-7/8	10-5/8	234	214
PVM(I/X)16-50	10	1.15	3	208-230/460	215TC	2	2	23-1/8	16-3/8	8-3/4	3-3/8	42-7/8	10-5/8	173	218
PVM(I/X)16-60	15	1.15	3	208-230/460	254TC	2	2	25-3/8	19-5/8	9-1/2	4-1/4	49-1/4	13	307	304
PVM(I/X)16-70	15	1.15	3	208-230/460	254TC	2	2	27-1/8	19-5/8	9-1/2	4-1/4	51	13	309	306
PVM(I/X)16-80	15	1.15	3	208-230/460	254TC	2	2	28-7/8	19-5/8	9-1/2	4-1/4	52-7/8	13	322	319
PVM(I/X)16-90	20	1.15	3	230/460	254TC	2	2	30 -1/4	21-3/4	9 1/8	4	56	11-1/2	389	324
PVM(I/X)16-100	20	1.15	3	230/460	254TC	2	2	32	21-3/4	9-1/8	4	57-3/4	11-1/2	398	333
PVM(I/X)16-110	25	1.15	3	230/460	284TSC	2	2	33 -3/4	21-3/4	9 -1/2	3-1/4	58-3/4	13	503	380
PVM(I/X)16-120	25	1.15	3	230/460	284TSC	2	2	35-3/8	21-3/4	9-1/2	3-1/4	60-3/8	13	506	383

* Measurements represent the largest number possible for each model using standard efficiency motors.

† Includes PMVI models constructed of 304 Stainless Steel and PVMX models constructed of 316 Stainless Steel.

PVM (I/X) 8 & 16 SERIES

Construction Materials

Description	Cast Iron	304 Stainless Steel	316 Stainless Steel	Optional Accessories
Shaft	AISI 431 SS	AISI 431 SS	AISI 316 SS	
Impellers, Diffuser Chambers, Pump Sleeve, Suction Interconnector, and Shaft Seal Parts	AISI 304 SS	AISI 304 SS	AISI 316 SS	
Suction/discharge Motor bracket	Class 30 Cast Iron	304 SS	316 SS	
Motor Couplings	Class 30 Cast Iron	Class 30 CI or 316 SS	Class 30 CI or 316 SS	
Intermediate Chamber Bearings	Class 30 Cast Iron	Class 30 Cast Iron	Class 30 Cast Iron	
Bearing Ring	Aluminum Oxide Ceramic	Aluminum Oxide Ceramic	Aluminum Oxide Ceramic	
O-Rings	Tungsten Carbide	Tungsten Carbide	Tungsten Carbide	Viton or Buna-N
Wear Rings	EPDM	EPDM	EPDM	
Sleeve O-Rings	Teflon	Teflon	Teflon	
Shaft Spacers	EPDM	EPDM	EPDM	Viton or Buna-N
Top Spring	AISI 316 SS	AISI 316 SS	AISI 316 SS	
Coupling Guard	AISI 316 SS	AISI 316 SS	AISI 316 SS	
Staybolts, Nuts & Washers	AISI 302 SS	AISI 302 SS	AISI 302 SS	
Mechanical Seal (High Pressure)	Zinc Plated Steel	Zinc Plated Steel	Zinc Plated Steel	
• Stationary Face	Tungsten Carbide	Tungsten Carbide	Tungsten Carbide	
• Rotating Face	Tungsten Carbide	Tungsten Carbide	Tungsten Carbide	
• O-Rings	EPDM	EPDM	EPDM	Viton or Buna-N
• Upper and Lower Drivers	AISI 316 SS	AISI 316 SS	AISI 316 SS	
• Spring	AISI 316 SS	AISI 316 SS	AISI 316 SS	

Performance Curves – PVM32 Series

3520 RPM*
3450 RPM

Based on Fresh Water @ 68 F.
Maximum Working Pressure: 230 PSI

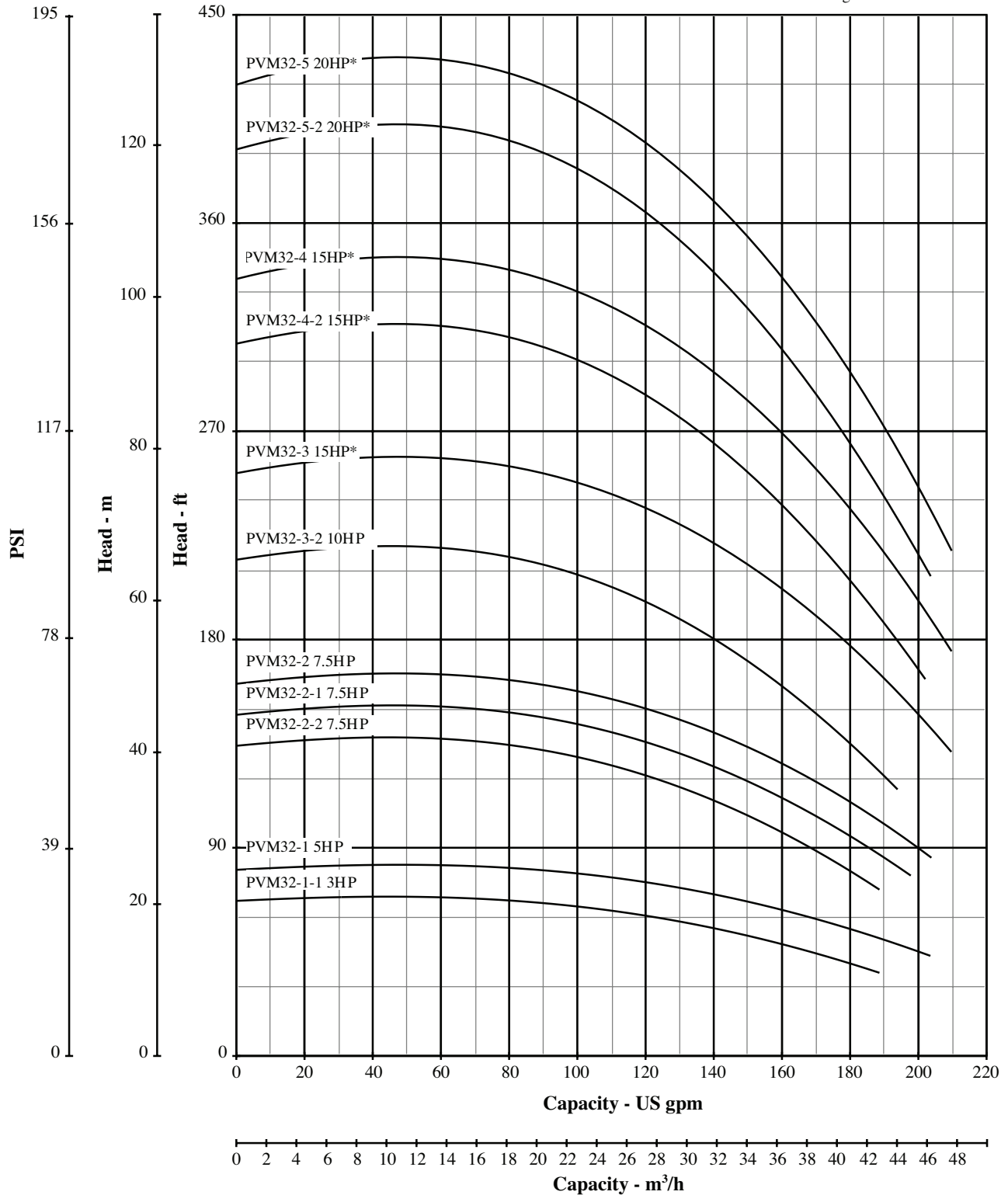

Performance Curves – PVM32 Series

3520 RPM*
3450 RPM

Based on Fresh Water @ 68 F.
Maximum Working Pressure: 435 PSI

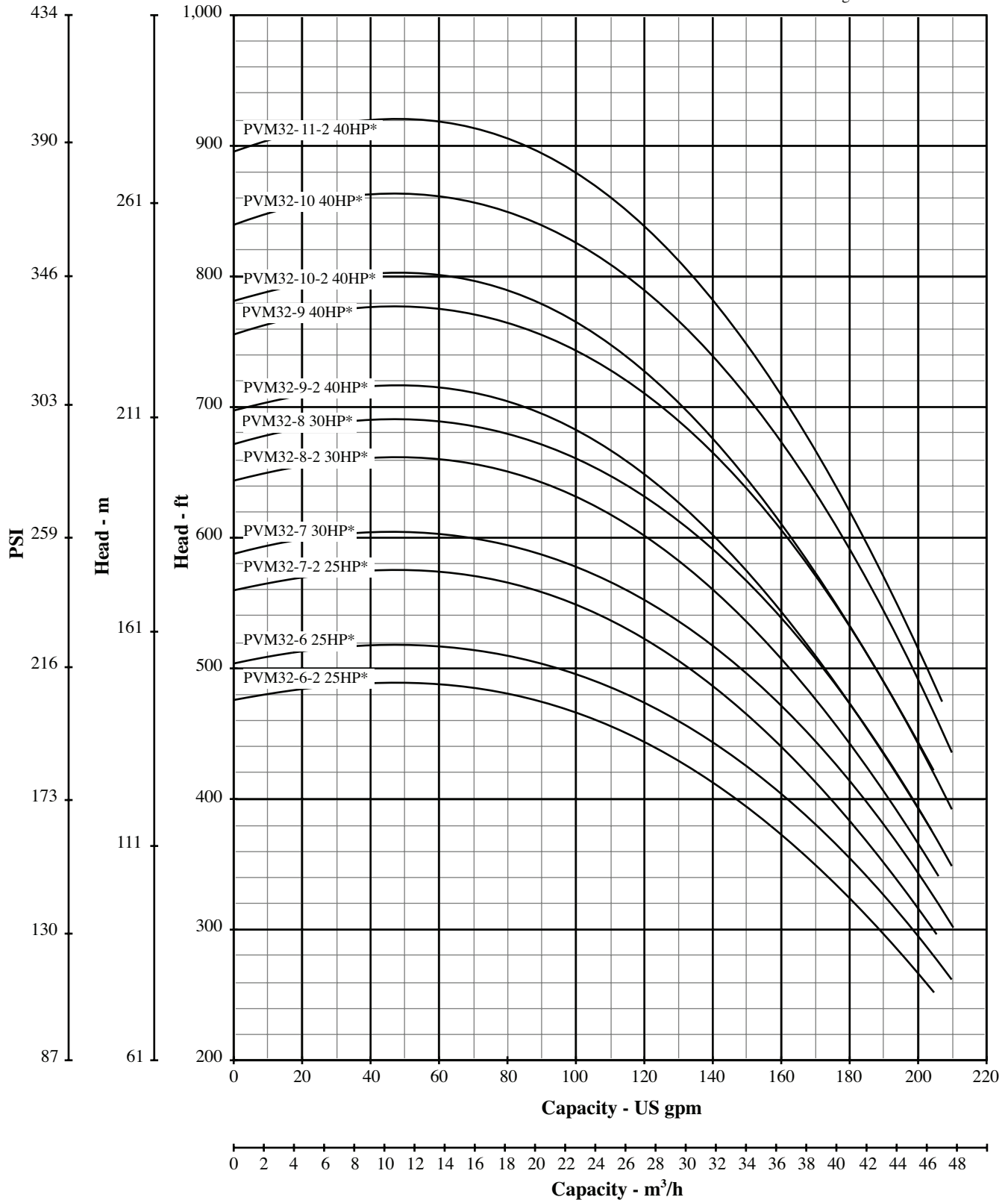

Single Stage Performance Data – PVM32 Series

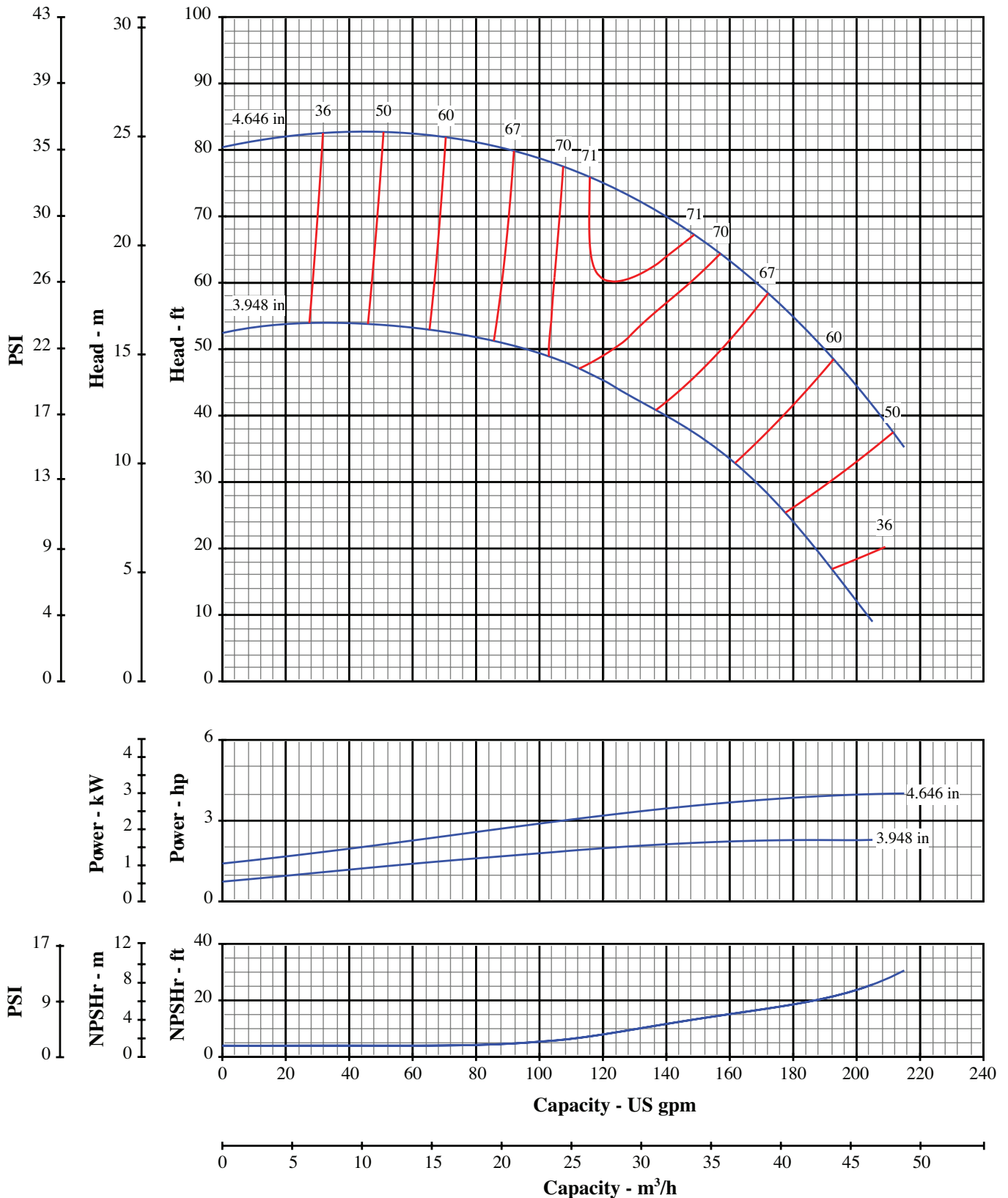

Cast Iron Construction

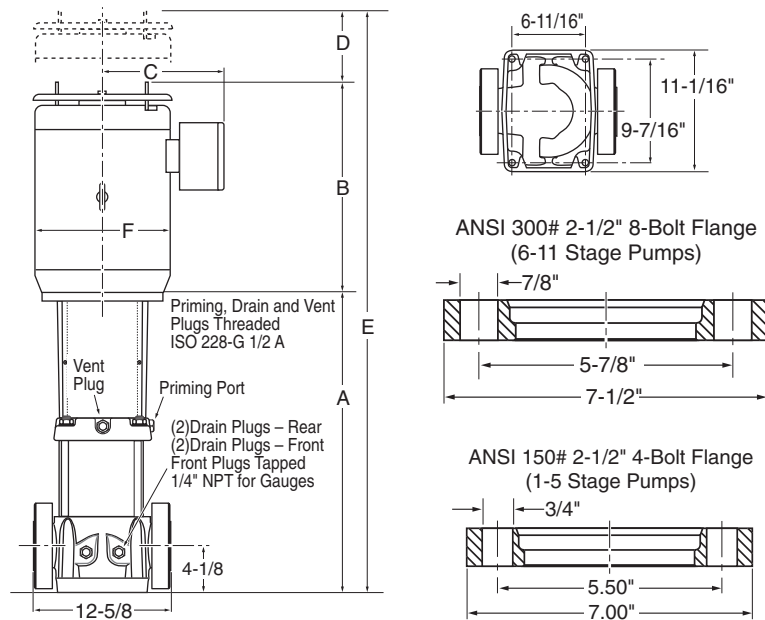

Technical Information

- MINIMUM PUMPING RATES:**
 - Up to 175° F - 15 GPM
 - 175° F to 250° F - 35 GPM
- FLOW RANGE:** 15 – 215 GPM
- MINIMUM SUCTION PIPE SIZES:** 2-1/2" Nominal Diameter, Schedule 40 Pipe
- MAXIMUM AMBIENT TEMPERATURE:** 104° F
- LIQUID TEMPERATURE RANGE:** +5° F to +250° F
- MOTOR OPTIONS:** TEFC or ODP
 - Single or Three Phase
 - For other options, consult factory.
- CONSTRUCTION MATERIALS:** See Page 34.

Dimensions and Specifications – PVM32 Series

Model Number	HP	Motor S.F.	Ph	Volts	Frame Size	Disc. Size	Suc. Size	Dimension in Inches*					
								A	B	C	D	E	F
PVM32-1-1	3	1.15	1	208-230	182TC	2-1/2	2-1/2	22.74	13.63	6.88	2.88	39.24	8.50
PVM32-1-1	3	1.15	3	208-230/460	182TC	2-1/2	2-1/2	22.74	13.63	6.88	2.88	39.24	8.50
PVM32-1	5	1.15	1	208-230	184TCZ	2-1/2	2-1/2	22.74	15.25	8.00	3.38	41.37	10.63
PVM32-1	5	1.15	3	208-230/460	213TC	2-1/2	2-1/2	22.74	15.25	8.00	3.38	41.37	10.63
PVM32-2-2	7.5	1.15	1	208-230	213TC	2-1/2	2-1/2	27.49	15.25	8.00	3.38	46.12	10.63
PVM32-2-2	7.5	1.15	3	208-230/460	213TC	2-1/2	2-1/2	27.49	15.25	8.00	3.38	46.12	10.63
PVM32-2-1	7.5	1.15	1	208-230	213TC	2-1/2	2-1/2	27.49	15.25	8.00	3.38	46.12	10.63
PVM32-2-1	7.5	1.15	3	208-230/460	213TC	2-1/2	2-1/2	27.49	15.25	8.00	3.38	46.12	10.63
PVM32-2	7.5	1.15	1	208-230	213TC	2-1/2	2-1/2	27.49	15.25	8.00	3.38	46.12	10.63
PVM32-2	7.5	1.15	3	208-230/460	213TC	2-1/2	2-1/2	27.49	15.25	8.00	3.38	46.12	10.63
PVM32-3-2	10	1.15	1	208-230	215TC	2-1/2	2-1/2	30.24	16.38	8.75	3.38	49.99	10.63
PVM32-3-2	10	1.15	3	208-230/460	215TC	2-1/2	2-1/2	30.24	16.38	8.75	3.38	49.99	10.63
PVM32-3	15	1.15	3	208-230/460	254TC	2-1/2	2-1/2	30.24	19.63	9.50	4.25	54.12	13.00
PVM32-4-2	15	1.15	3	208-230/460	254TC	2-1/2	2-1/2	33.00	19.63	9.50	4.25	56.88	13.00
PVM32-4	15	1.15	3	208-230/460	254TC	2-1/2	2-1/2	33.00	19.63	9.50	4.25	56.88	13.00
PVM32-5-2	20	1.15	3	230/460	254TC	2-1/2	2-1/2	35.75	21.75	9.13	4.00	61.50	11.50
PVM32-5	20	1.15	3	230/460	254TC	2-1/2	2-1/2	35.75	21.75	9.13	4.00	61.50	11.50
PVM32-6-2	25	1.15	3	230/460	284TSC	2-1/2	2-1/2	38.51	21.75	9.13	3.25	63.51	13.00
PVM32-6	25	1.15	3	230/460	284TSC	2-1/2	2-1/2	38.51	21.75	9.13	3.25	63.51	13.00
PVM32-7-2	25	1.15	3	230/460	284TSC	2-1/2	2-1/2	41.25	21.75	9.13	3.25	66.25	13.00
PVM32-7	30	1.15	3	230/460	284TSC	2-1/2	2-1/2	41.25	22.94	13.11	3.25	67.44	14.88
PVM32-8-2	30	1.15	3	230/460	284TSC	2-1/2	2-1/2	44.02	22.94	13.11	3.25	70.21	14.88
PVM32-8	30	1.15	3	230/460	284TSC	2-1/2	2-1/2	44.02	22.94	13.11	3.25	70.21	14.88
PVM32-9-2	40	1.15	3	230/460	286TSC	2-1/2	2-1/2	46.78	22.94	13.13	3.25	72.97	14.91
PVM32-9	40	1.15	3	230/460	286TSC	2-1/2	2-1/2	46.78	22.94	13.13	3.25	72.97	14.91
PVM32-10-2	40	1.15	3	230/460	286TSC	2-1/2	2-1/2	49.53	22.94	13.13	3.25	75.72	14.91
PVM32-10	40	1.15	3	230/460	286TSC	2-1/2	2-1/2	49.53	22.94	13.13	3.25	75.72	14.91
PVM32-11-2	40	1.15	3	230/460	286TSC	2-1/2	2-1/2	52.29	22.94	13.13	3.25	78.48	14.91

* Measurements represent the largest number possible for each model using standard efficiency motors.

Materials of Construction

Description	Material	Description	Material
Shaft	AISI 431 SS	Lower Shaft Stabilizer Bearing	Tungsten Carbide
Impellers		O-Rings	EPDM opt:Viton, Buna-N
Diffuser Chambers, Pump Sleeve		Neck Rings	Teflon
Split Cones and Split Cone Nuts, and Suction Interconnector	AISI 304 SS	Coupling Guard	AISI 304 SS
Motor Stool	Class 30 Cast Iron	Staybolts, Nuts & Washers	Zinc Plated Steel
Suction/discharge, Pump Head, and Motor Couplings	80-55-06 Ductile Iron	Mechanical Seal	
Intermediate Bearings	Leadless Tin Bronze	• Stationary Face	Tungsten Carbide
Diffuser Sleeves	Graphite	• Rotating Face	Tungsten Carbide
Bearing Ring	Tungsten Carbide	• O-Rings	EPDM opt:Viton, Buna-N
		• Upper and Lower Drivers	AISI 304 SS or Better
		• Spring	AISI 316 SS
		Seal Carrier	UNIC 40 Epoxy Coated Steel

Permissible Operating Pressure Curves

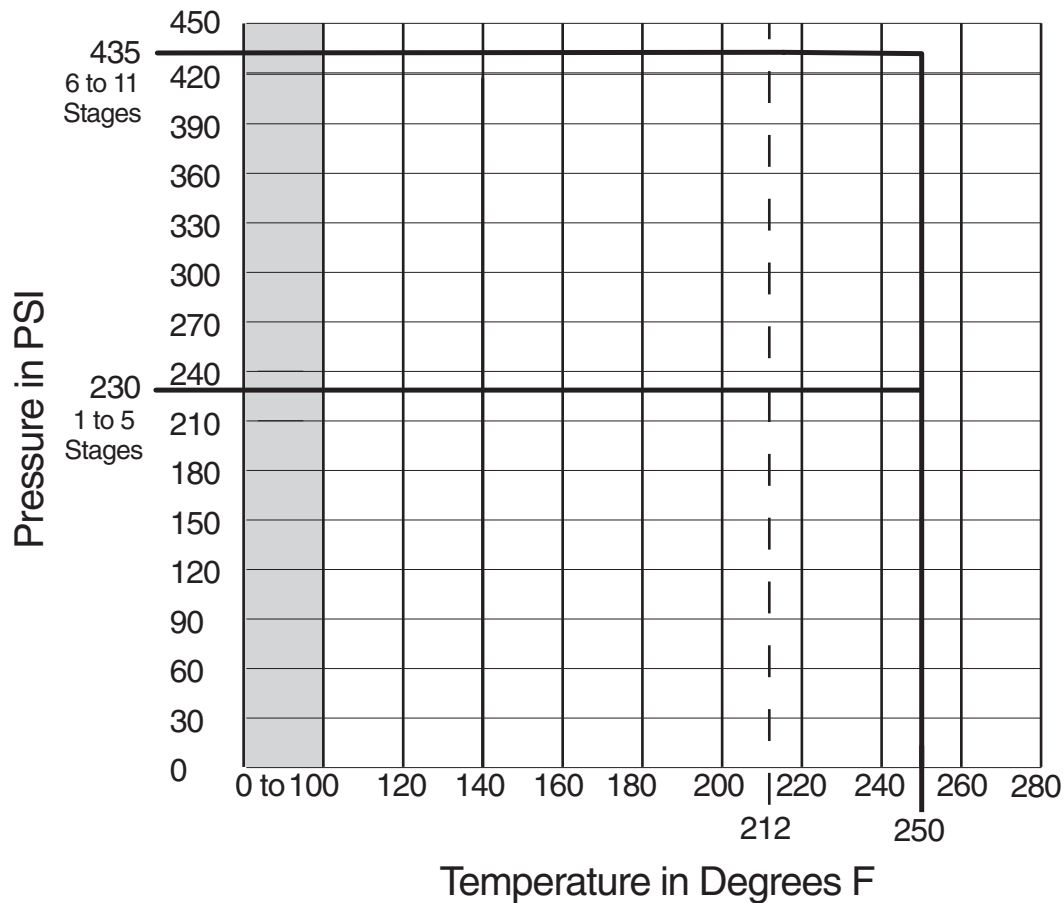

Bypass Orifice Sizing

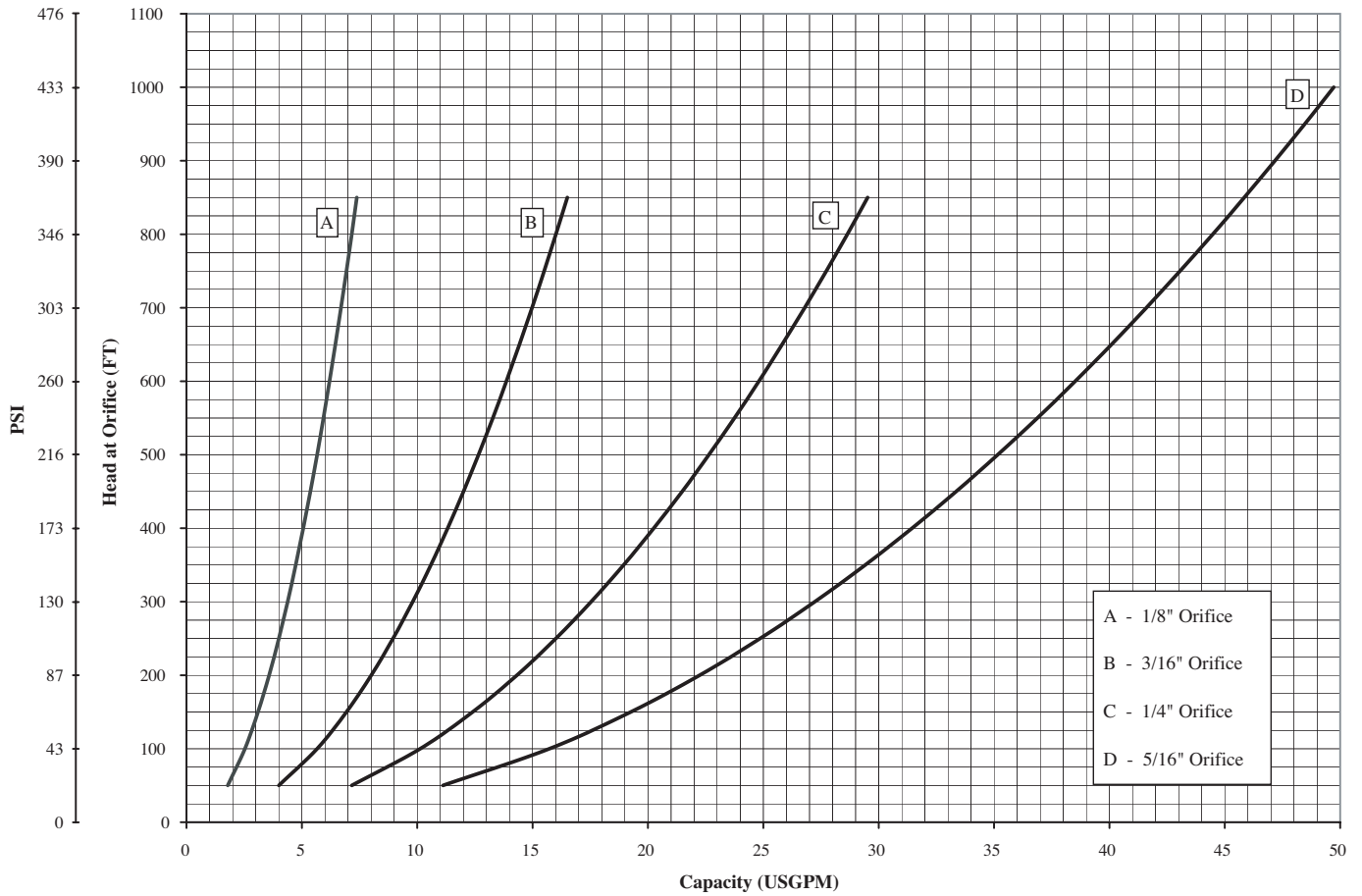

AURORA LIMITED WARRANTY

Aurora warrants to the original consumer purchaser ("Purchaser") of its products that they are free from defects in material or workmanship.

If within twelve (12) months from the date of installation or twenty-four (24) months from the date of manufacture any such product shall prove to be defective, it shall be repaired or replaced at Aurora's option, subject to the terms and conditions set forth below.

General Terms and Conditions

Purchaser must pay all labor and shipping charges necessary to replace product covered by this warranty. This warranty shall not apply to products which, in the sole judgement of Aurora, have been subject to negligence, abuse, accident, misapplication, tampering, alteration; nor due to improper installation, operation, maintenance or storage; nor to other than normal application, use or service, including but not limited to, operational failures caused by corrosion, rust or other foreign materials in the system, or operation at pressures in excess of recommended maximums.

Requests for service under this warranty shall be made by contacting the installing Aurora/Wicor dealer as soon as possible after the discovery of any alleged defect. Aurora will subsequently take corrective action as promptly as reasonably possible. No requests for service under this warranty will be accepted if received more than 30 days after the term of the warranty.

The warranty on all three phase submersible motors is void if three-leg overload protection of recommended size is not used.

This warranty sets forth Aurora's sole obligation and purchaser's exclusive remedy for defective products. AURORA SHALL NOT BE LIABLE FOR ANY CONSEQUENTIAL, INCIDENTAL, OR CONTINGENT DAMAGES WHATSOEVER.

THE FOREGOING WARRANTIES ARE EXCLUSIVE AND IN LIEU OF ALL OTHER EXPRESS WARRANTIES. IMPLIED WARRANTIES, INCLUDING BUT NOT LIMITED TO THE IMPLIED WARRANTIES OF MERCHANTABILITY AND FITNESS FOR A PARTICULAR PURPOSE, SHALL NOT EXTEND BEYOND THE DURATION OF THE APPLICABLE EXPRESS WARRANTIES PROVIDED HEREIN.

Some states do not allow the exclusion or limitation of incidental or consequential damages or limitations on how long an implied warranty lasts, so the above limitations or exclusions may not apply to you. This warranty gives you specific legal rights and you may also have other rights which vary from state to state.

Aurora Pump, 800 Airport Road, North Aurora, IL 60542



motralec

4 rue Lavoisier . ZA Lavoisier . 95223 HERBLAY CEDEX
Tel. : 01.39.97.65.10 / Fax. : 01.39.97.68.48
Demande de prix / e-mail : service-commercial@motralec.com
www.motralec.com